



International Civil Aviation Organization

AMHS WORKSHOP

REGIONAL WORKSHOP ON AMHS

INTRODUCTION – PART II

(Dakar, 28-29 May 2013)



Outline

- ✈ Introduction
- ✈ Functional Components
- ✈ End Users
- ✈ Levels of Service
- ✈ Interoperability



Introduction

- The ATN technical specifications for the Air Traffic Services Message-Handling Service (ATSMHS) define the ICAO store and forward messaging service used to exchange ATS messages between users over the ATN internet.
- The set of computing and communication resources implemented by Air Navigation Service Providers (ANSP) to provide the ATS Message Handling Service is commonly referred to as AMHS (ATS Message Handling System).
- The ATS Message Handling System technical specifications are compliant with mature message handling systems standards such as ISO/IEC 10021 [23] and ITU-T X.400.



Functional Components

- In terms of functionality, the ATSMHS comprises the following components:
 - (a) the Message Transfer Agent (MTA) which performs the function of the message switch,
 - (b) the User Agent (UA) which performs the user access to the MTA and provides an appropriate user interface,
 - (c) the Message Store (MS) which provides the intermediary storage between MTA and UA and is usually co-located with the MTA, and
 - (d) the Access Unit (AU) which provides for intercommunication with other Messaging Systems.



End Systems

- Three categories of ATN end systems are defined for the support of the ATS Message Handling Service:
 - · the ATS message server
 - · the ATS message user agent
 - · the AFTN/AMHS gateway
- Together, these systems provide connectivity between users at ATN end systems and users at AFTN Stations in three different end-to-end configurations:
 - a) from an AFTN/CIDIN Station to another AFTN Station over the ATN;
 - b) from an AFTN/CIDIN Station to an ATN End System, and vice versa;
 - c) from an ATN End System to another ATN End System.



Levels of Service

- ✈ Two levels of service are defined within the ATS Message Handling Service:
 - 1. The Basic ATS Message Handling Service;
 - 2. The Extended ATS Message Handling Service.
- ✈ **The Basic ATS Message Handling Service** meets the basic requirements of the MHS Profiles published by ISO as International Standardized Profiles (ISPs), and it incorporates additional features to support the service offered by the AFTN.
- ✈ Compared to the service of the AFTN, the Basic ATS Message Handling Service offers some significant improvements such as:
 - · practically unlimited message length;
 - · virtually no limit on the number of addressees of a message;
 - · provision of non-delivery reports;
 - · indication of the subject of a message.



Levels of Service

- ➔ **The Extended ATS Message Handling Service** provides functionality in addition to those of the Basic ATS Message Handling Service such as the introduction of directory services and security mechanisms. Furthermore, in addition to IA-5 text, the extended service allows for the transfer of binary coded data, files etc.
- ➔ The Extended ATS Message Handling Service is backwards compatible with the Basic ATS Message Handling Service.

AMHS Servers & User Agents

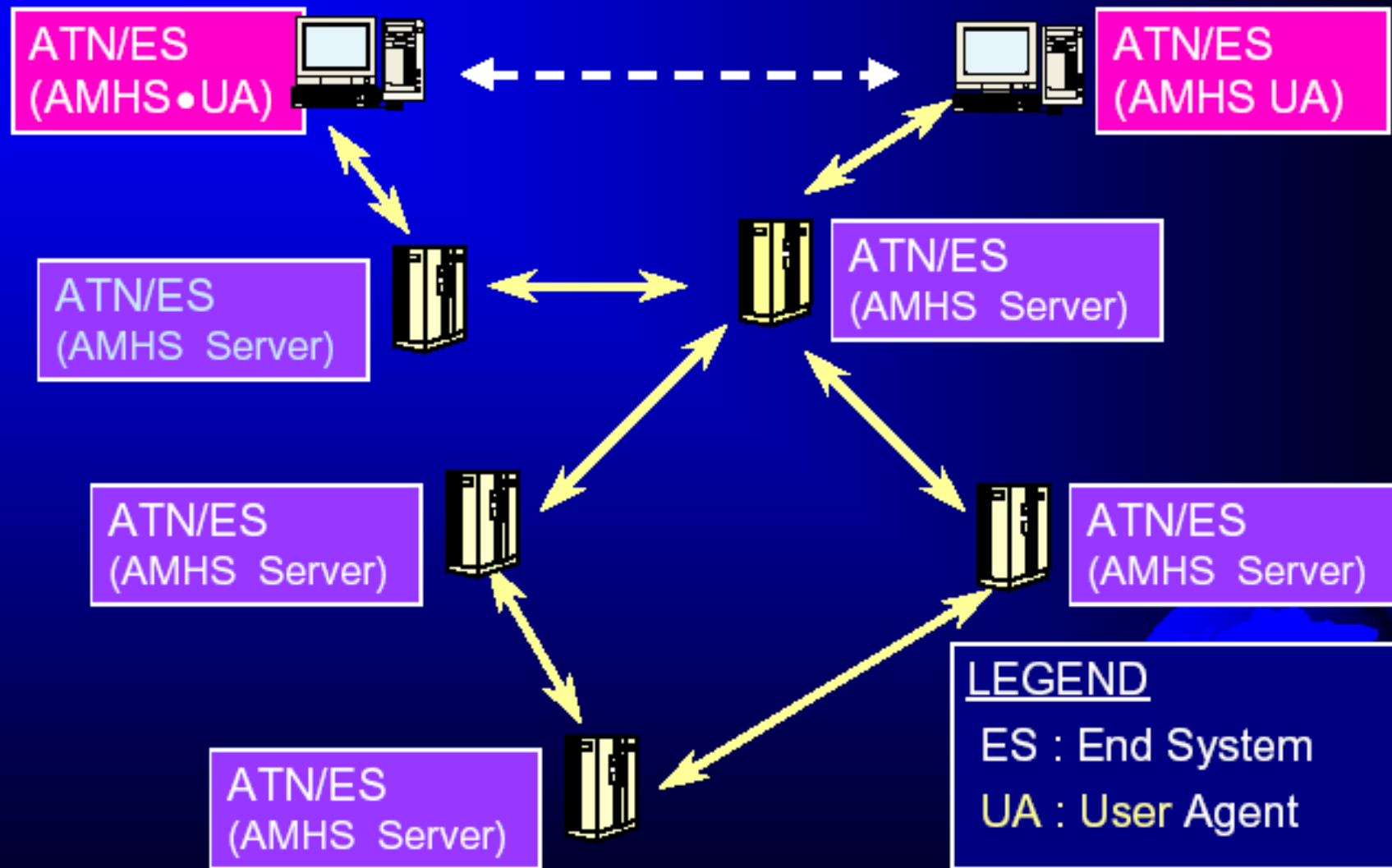

Messaging among Servers

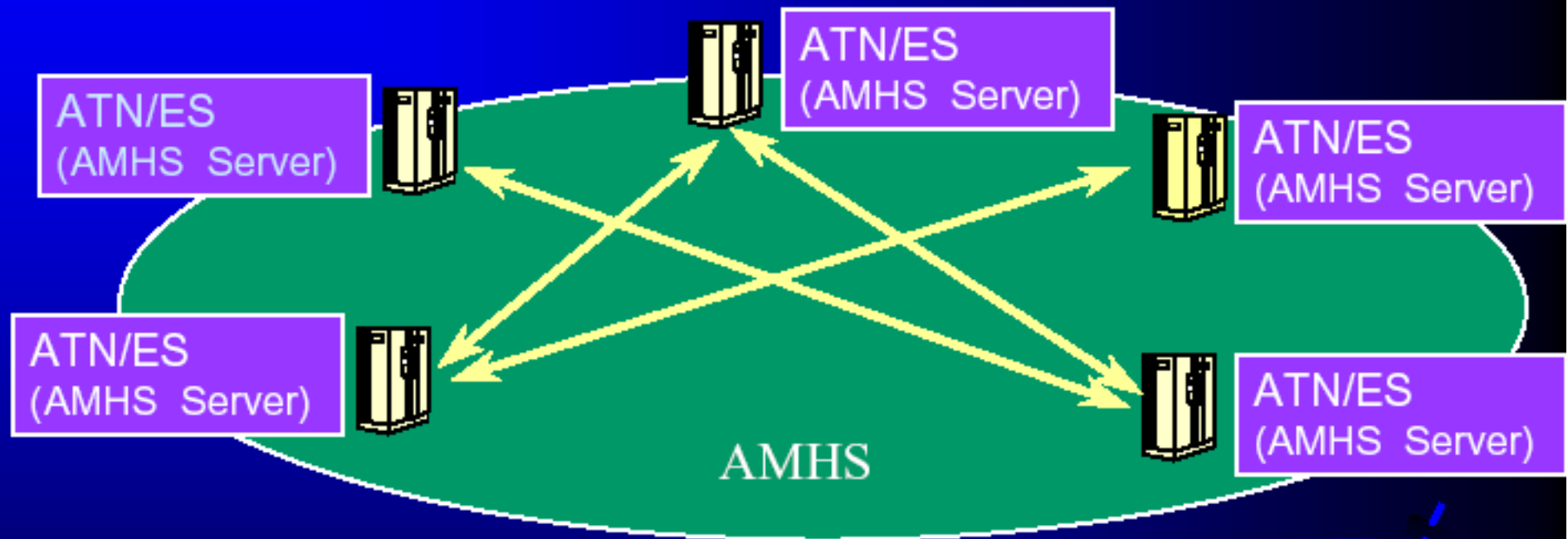

Messaging among Servers

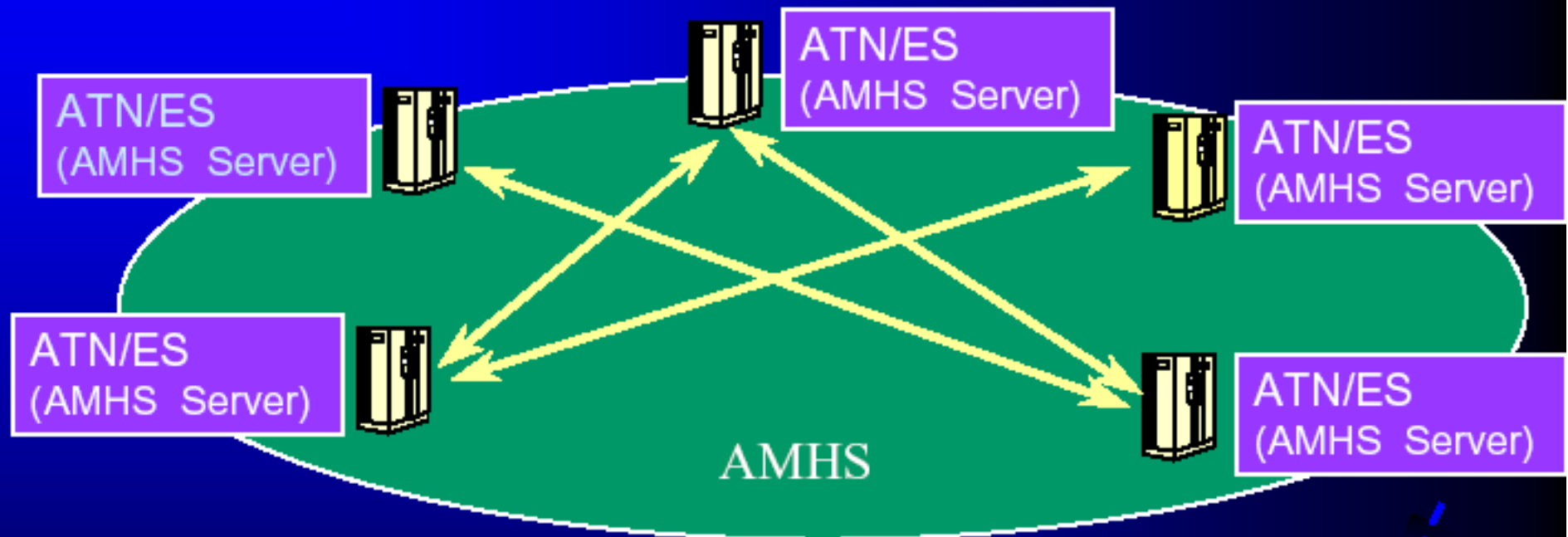

AMHS and ATN Internetwork

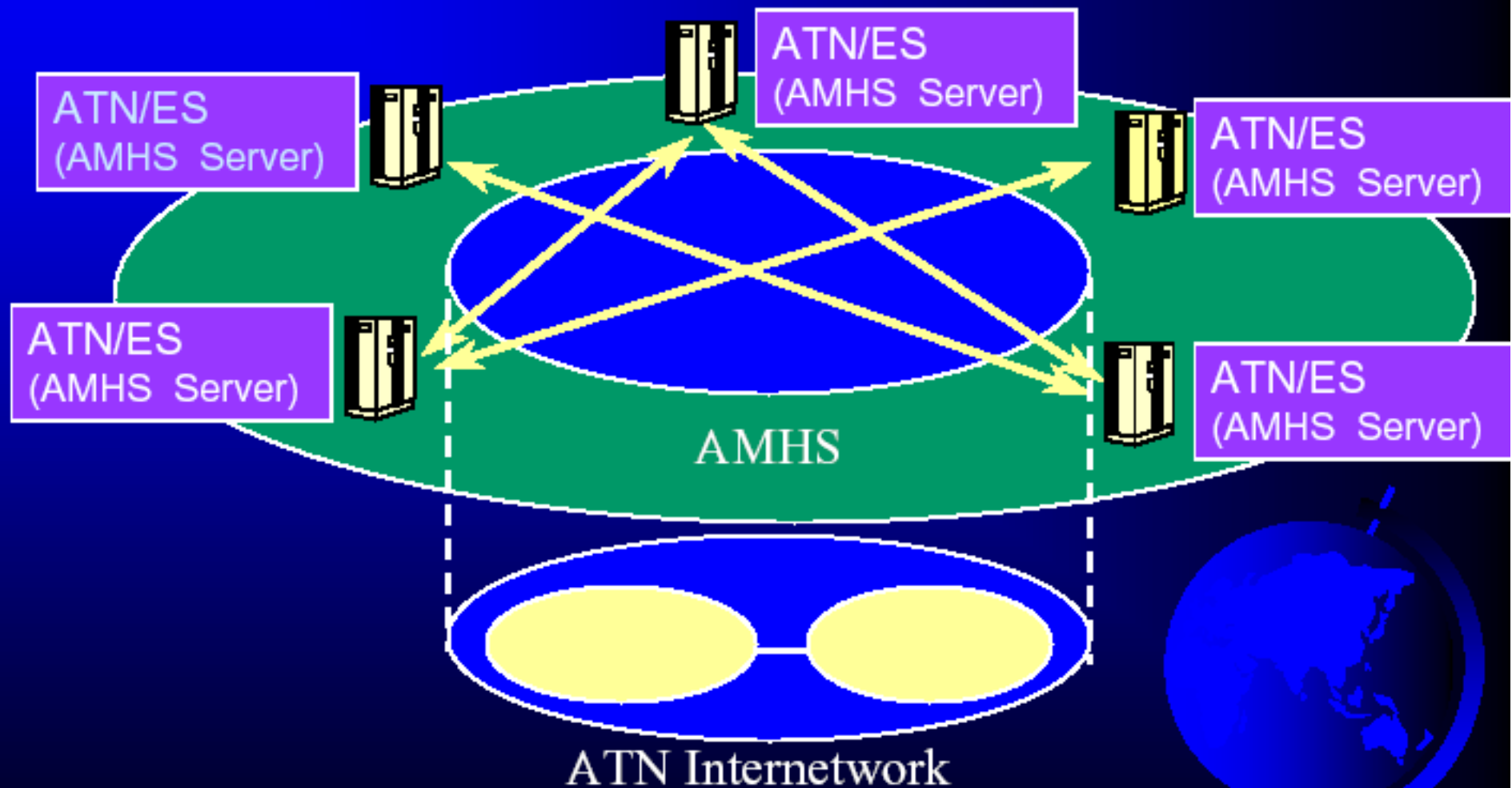

Inter-Domain Connection

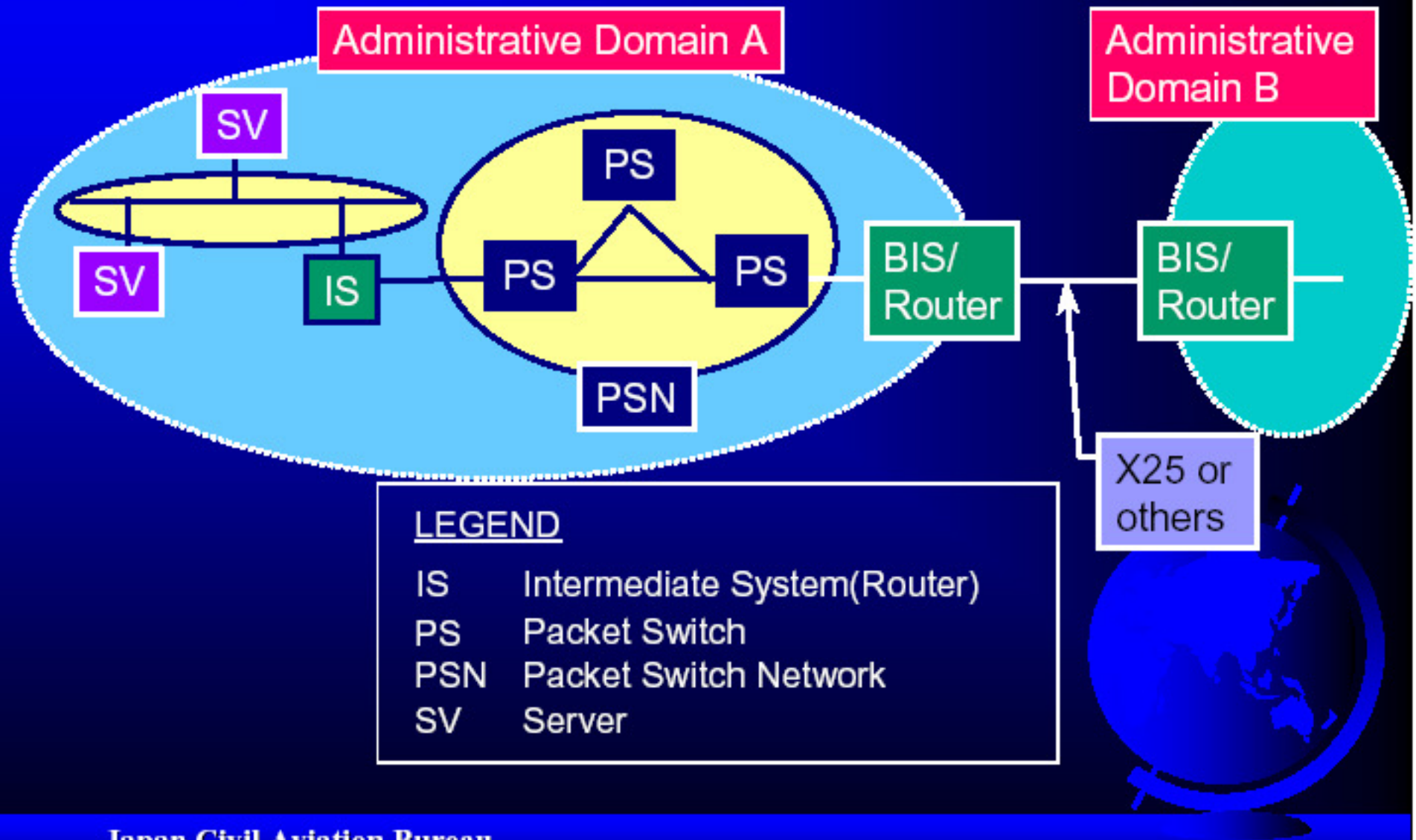

LEGEND

- IS Intermediate System(Router)
- PS Packet Switch
- PSN Packet Switch Network
- SV Server

AMHS User-to-AMHS User

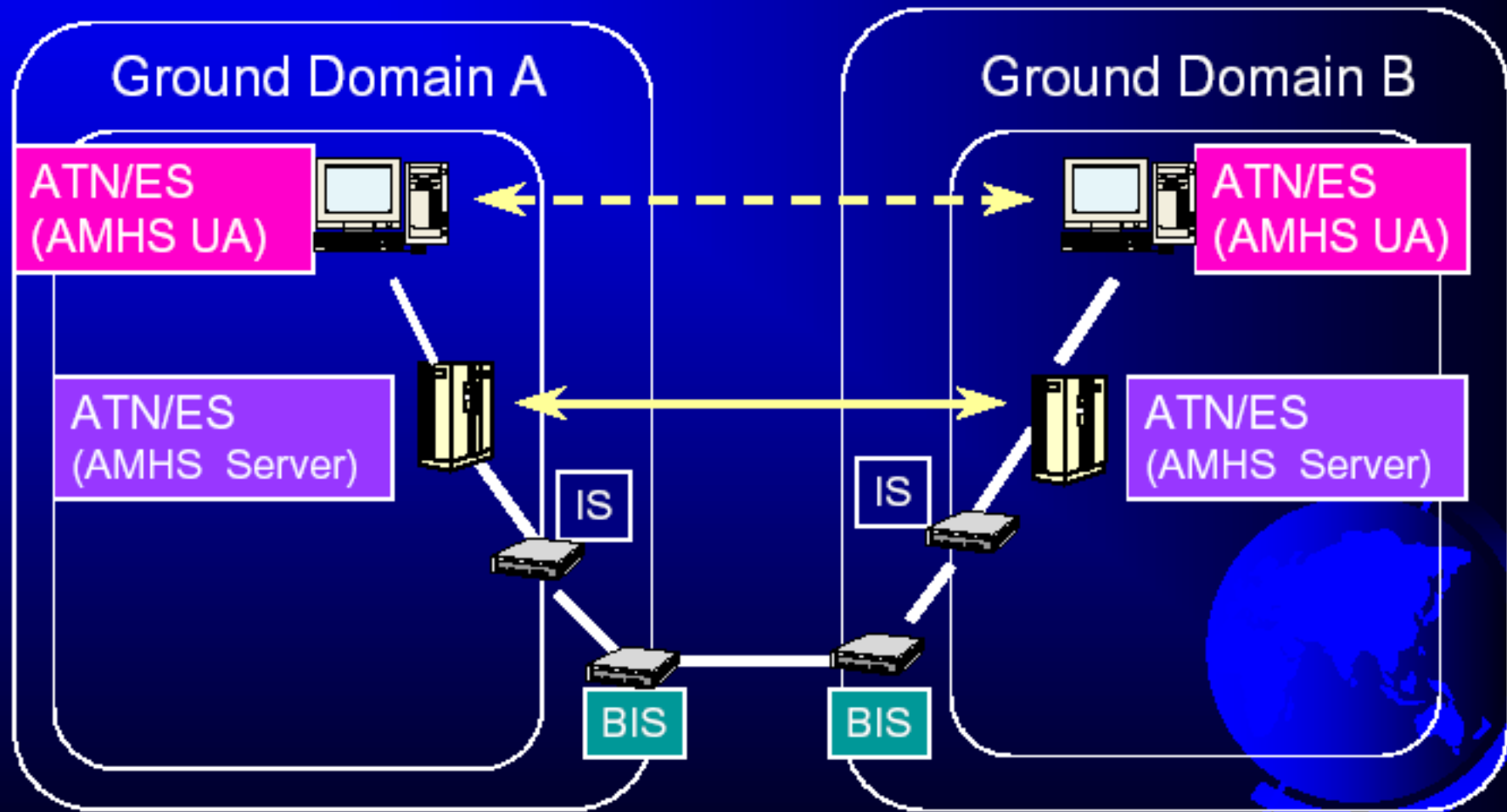

Interoperability



- ✈ During the transition phase from the AFTN or the CIDIN to the AMHS the interoperability between systems is achieved by the use of the AFTN/AMHS gateway.
- ✈ The technical specifications for the AFTN/AMHS gateway have been defined by ICAO.

AMHS User-to-AFTN User via AFTN/AMHS Gateway

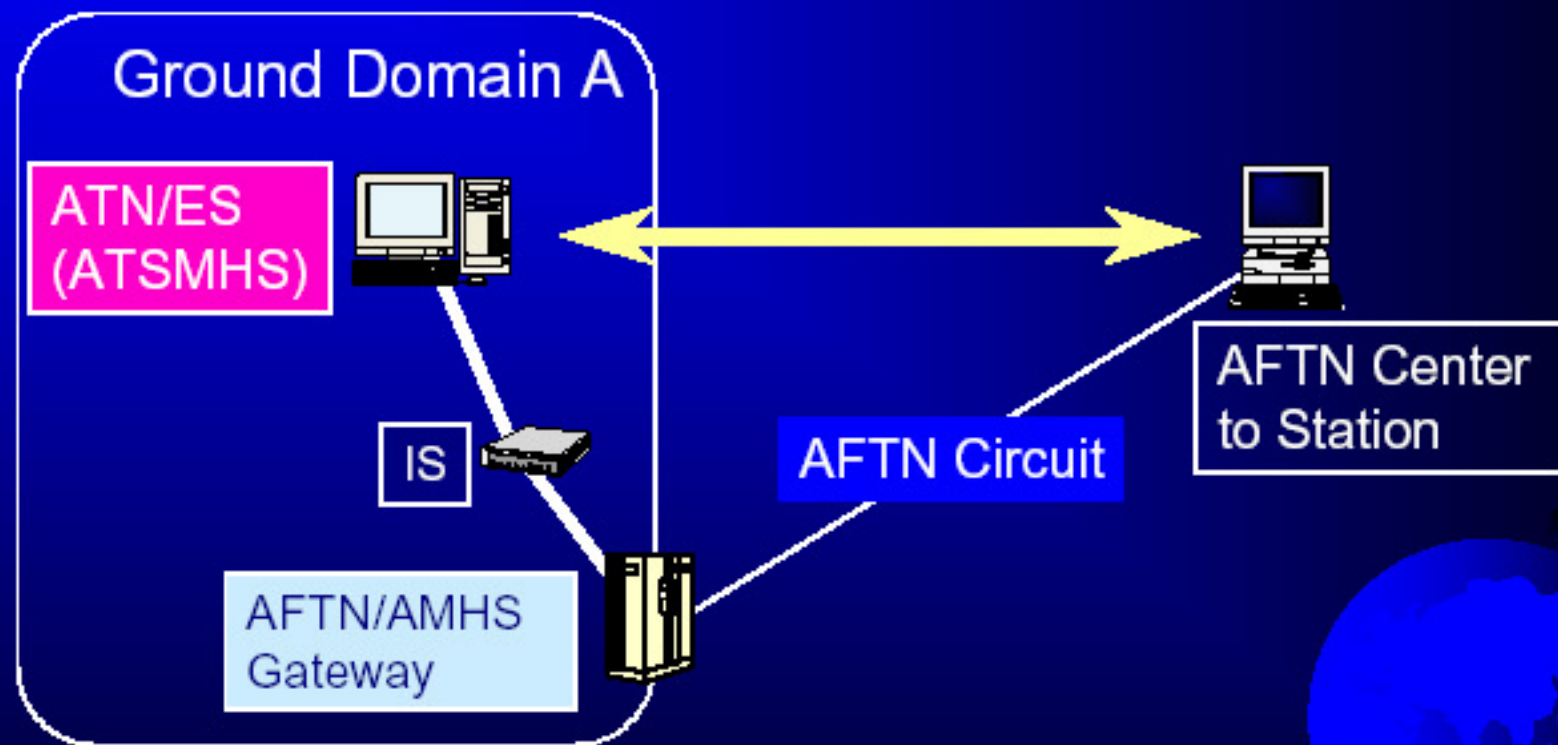

AFTN User-to- AFTN User via AFTN/AMHS Gateway and ATN Domains

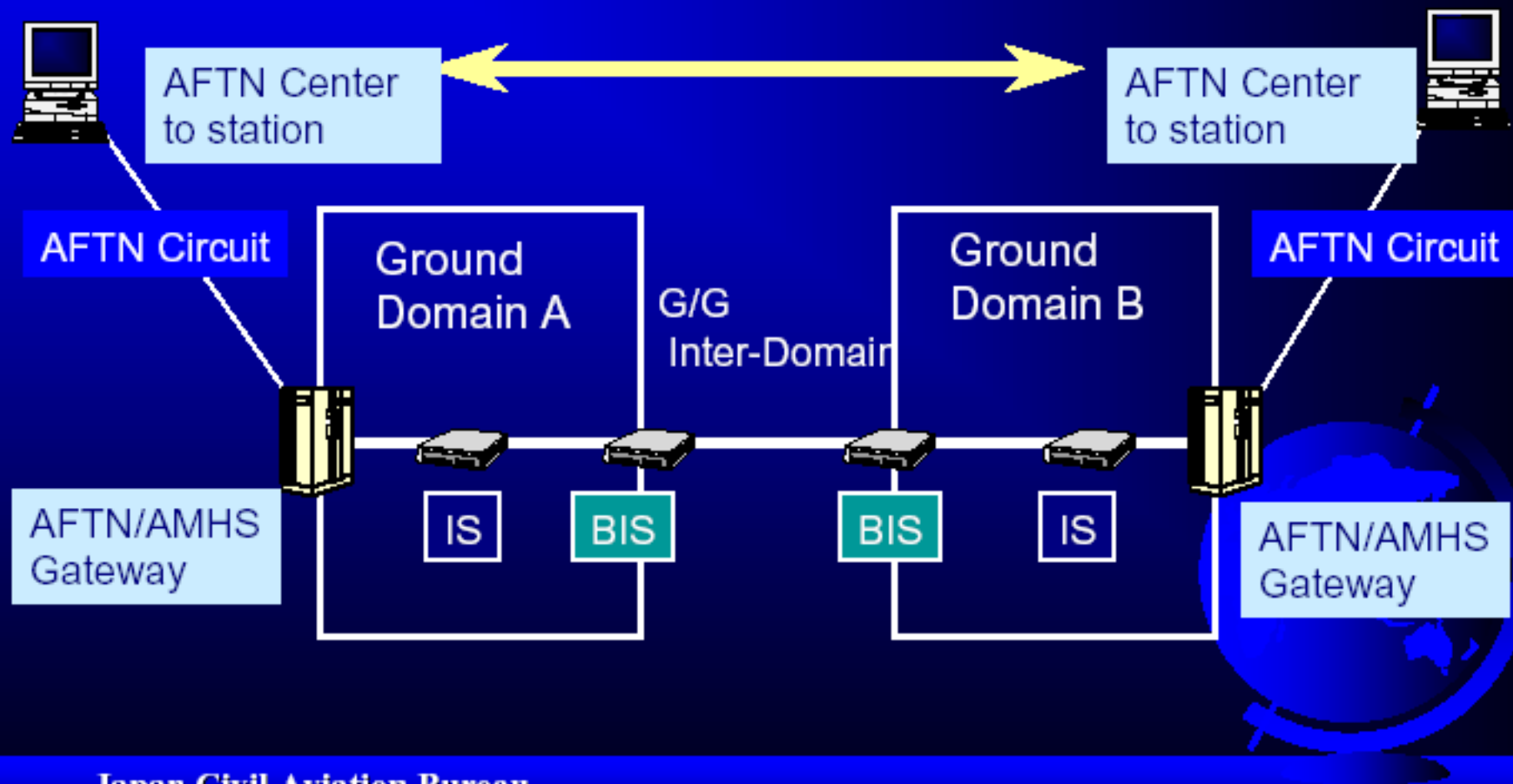

AFTN Service to ATN/AMHS Service

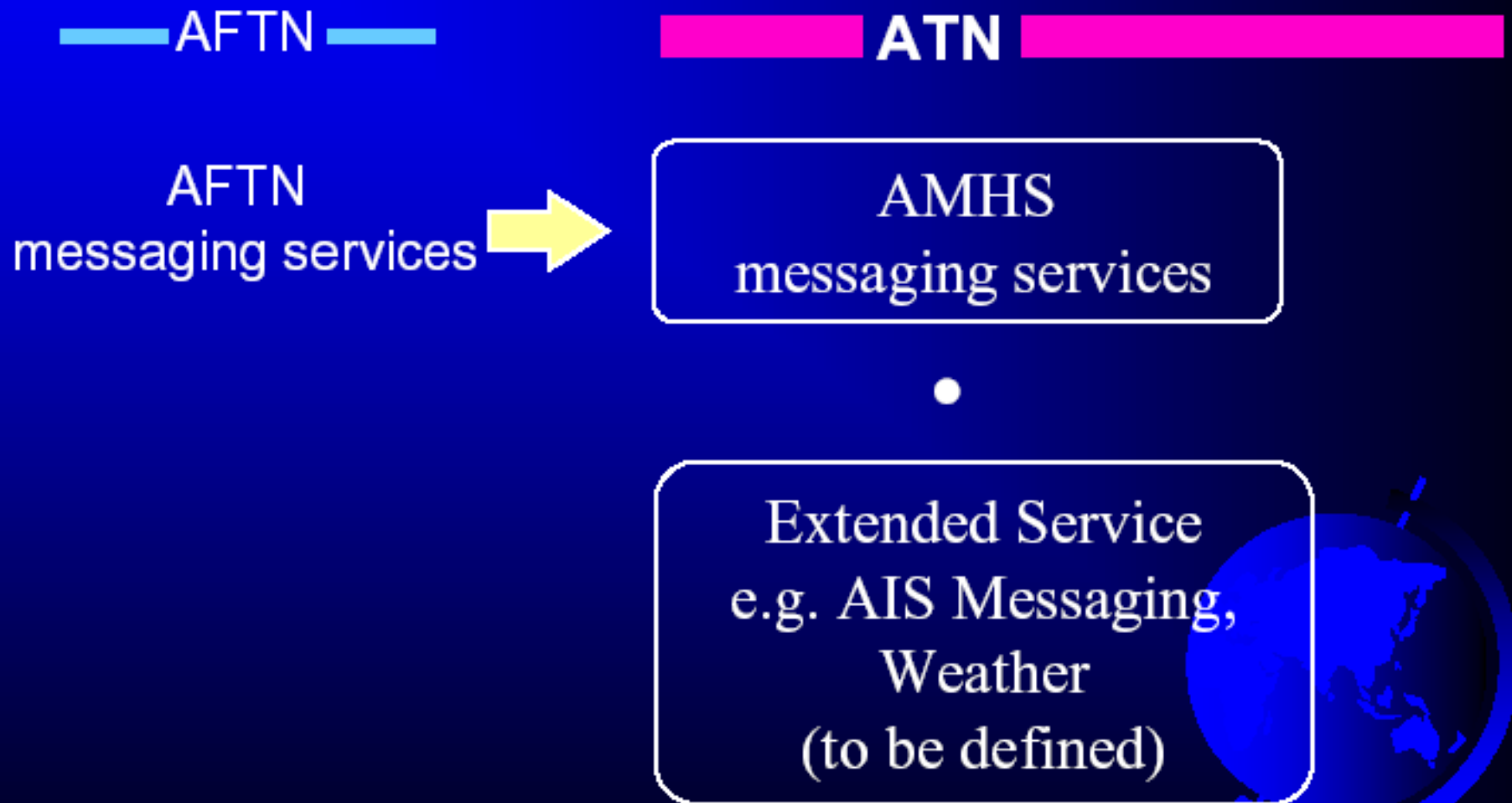

AFTN/AMHS Gateway

- ◆ Allow Transition from AFTN to ATN
- ◆ AFTN and ATN/AMHS co-existence
- ◆ AFTN/AMHS gateway : AFTN messages are converted to ATSMHS messages, or vice versa. It provides inter-working between AFTN and ATN at the message level.



AFTN/AMHS Gateways (continued)

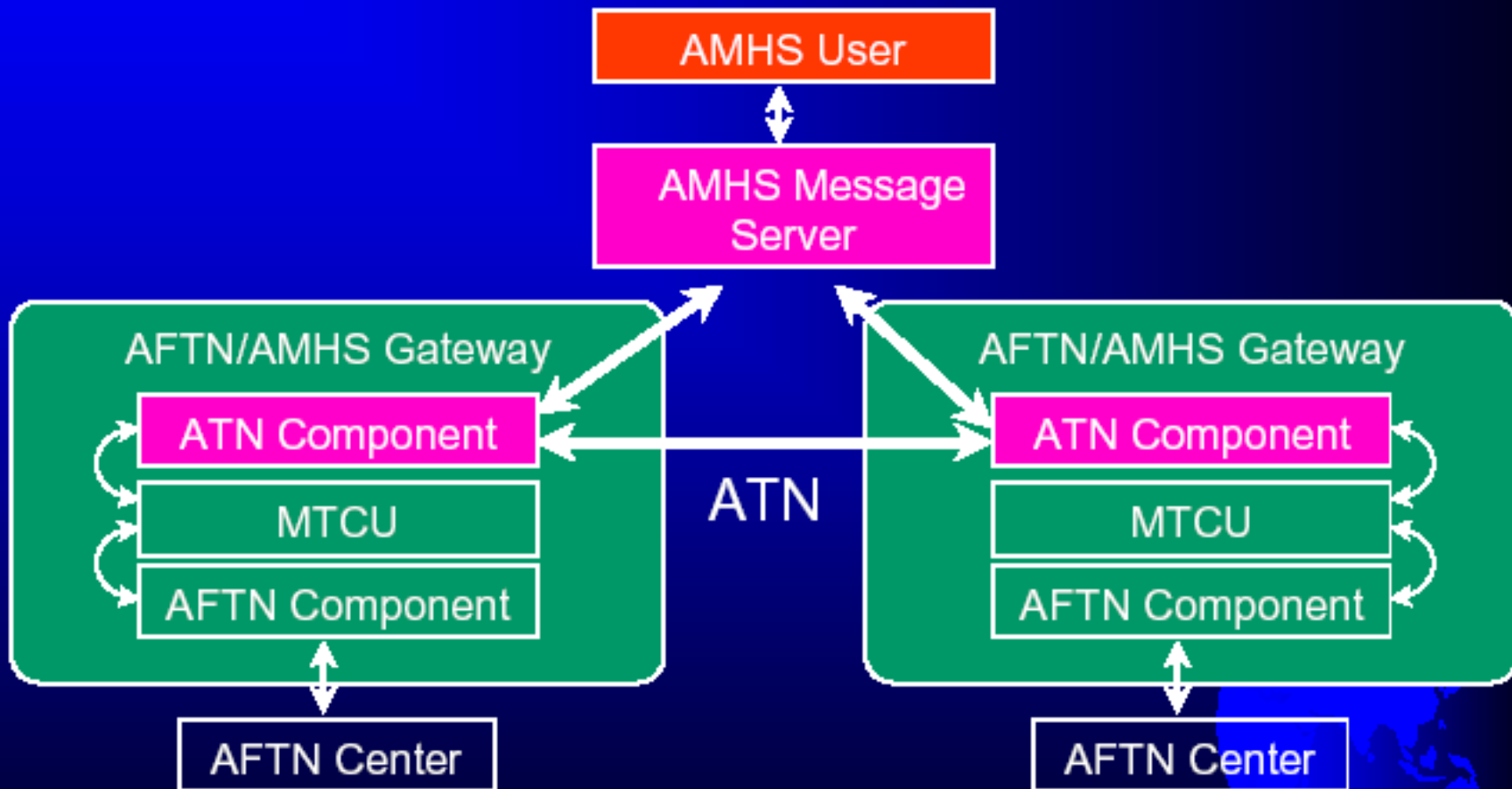

MTCU: Message Transfer Control Unit

Some Examples of AMHS Messaging

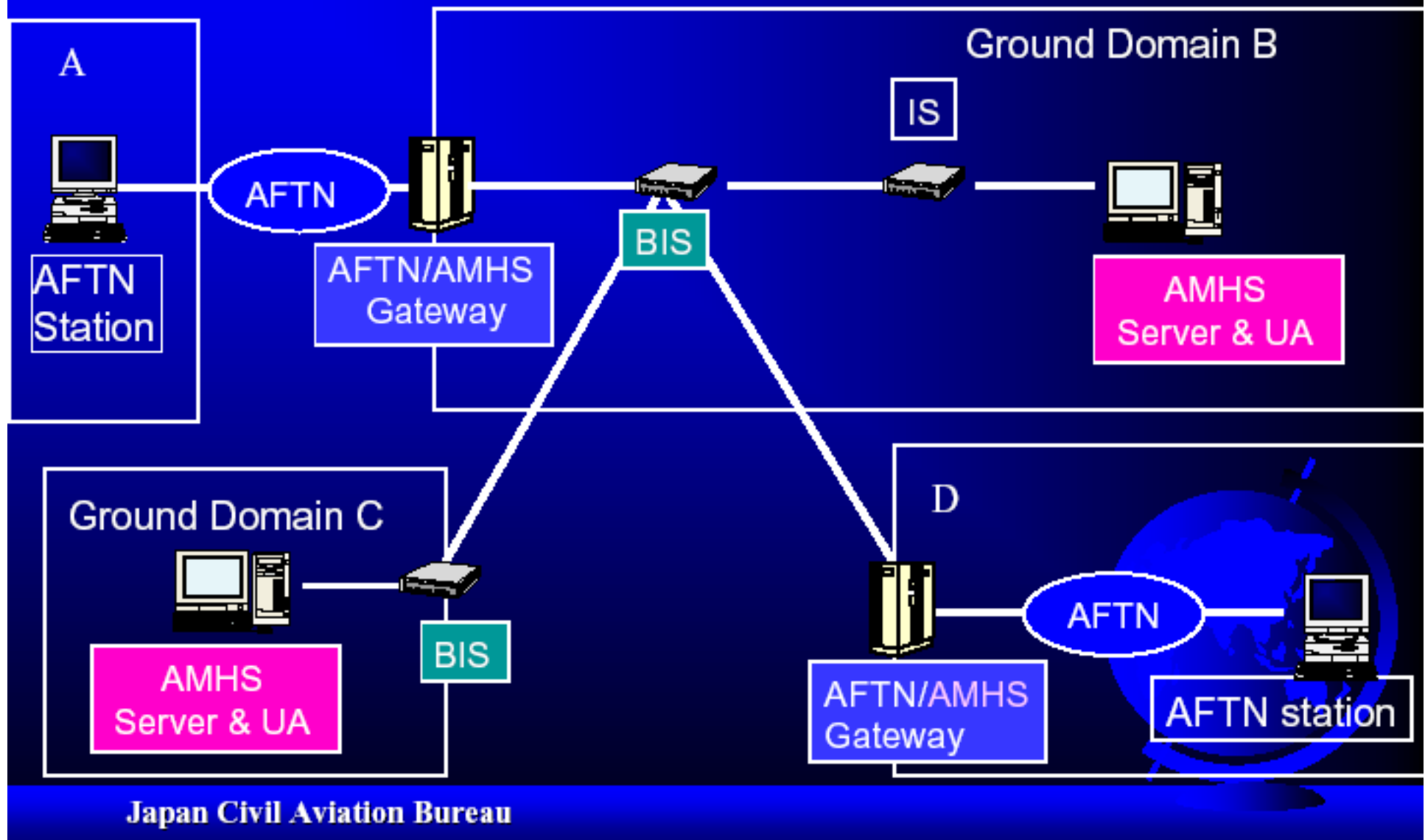

AMHS User-to-AMHS User

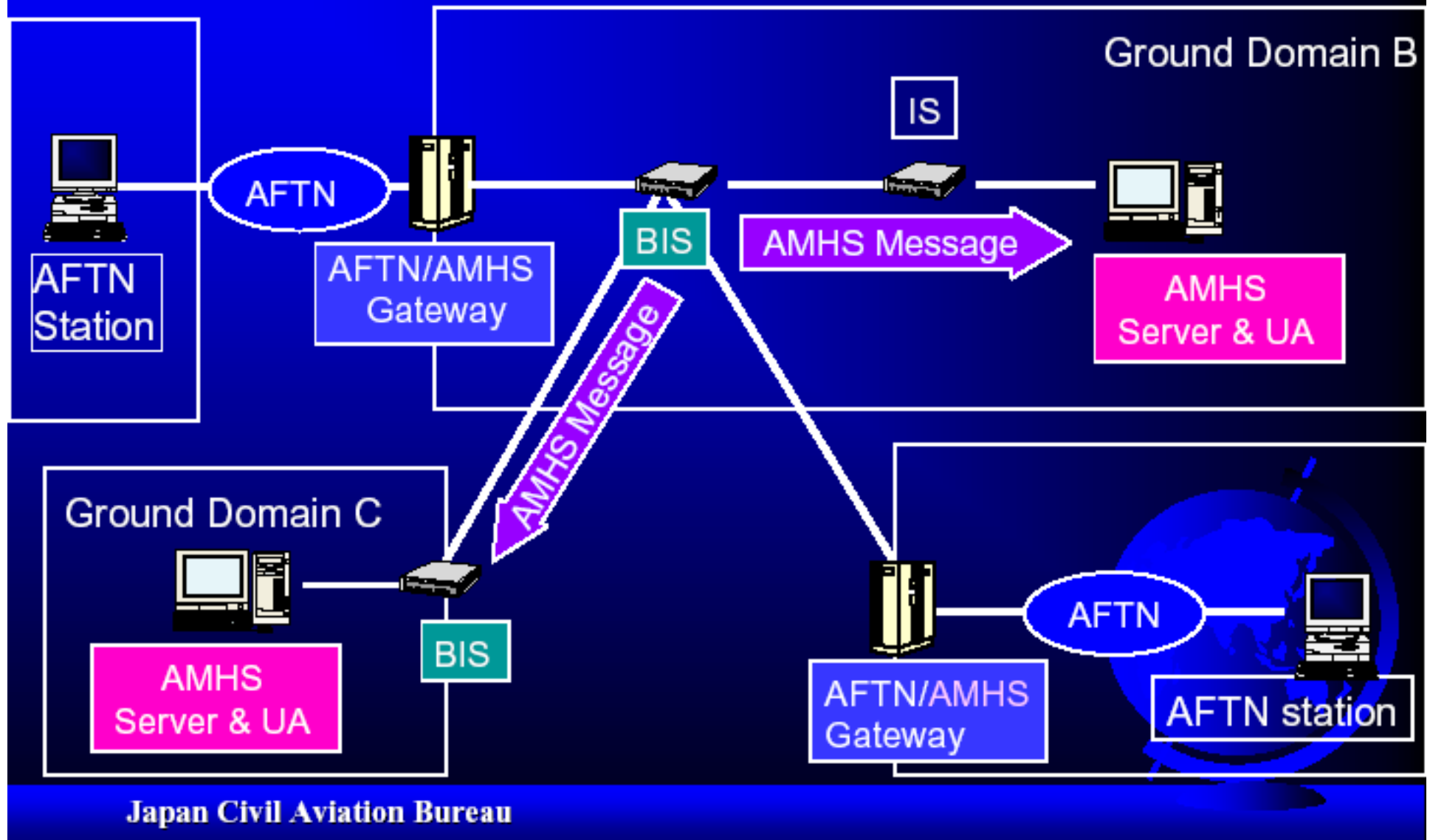

AMHS User-to-AFTN User

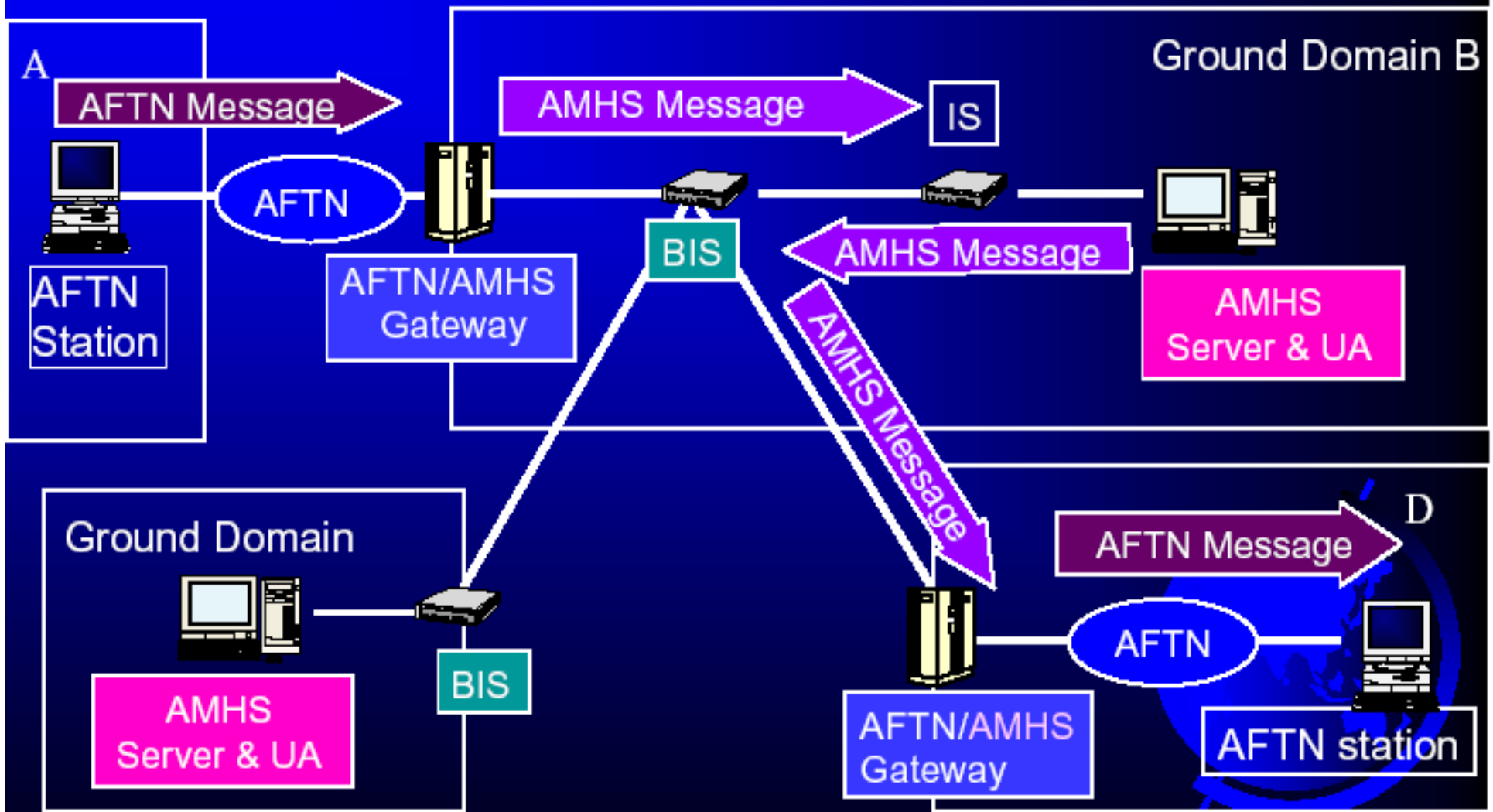

AFTN User-to-AFTN User

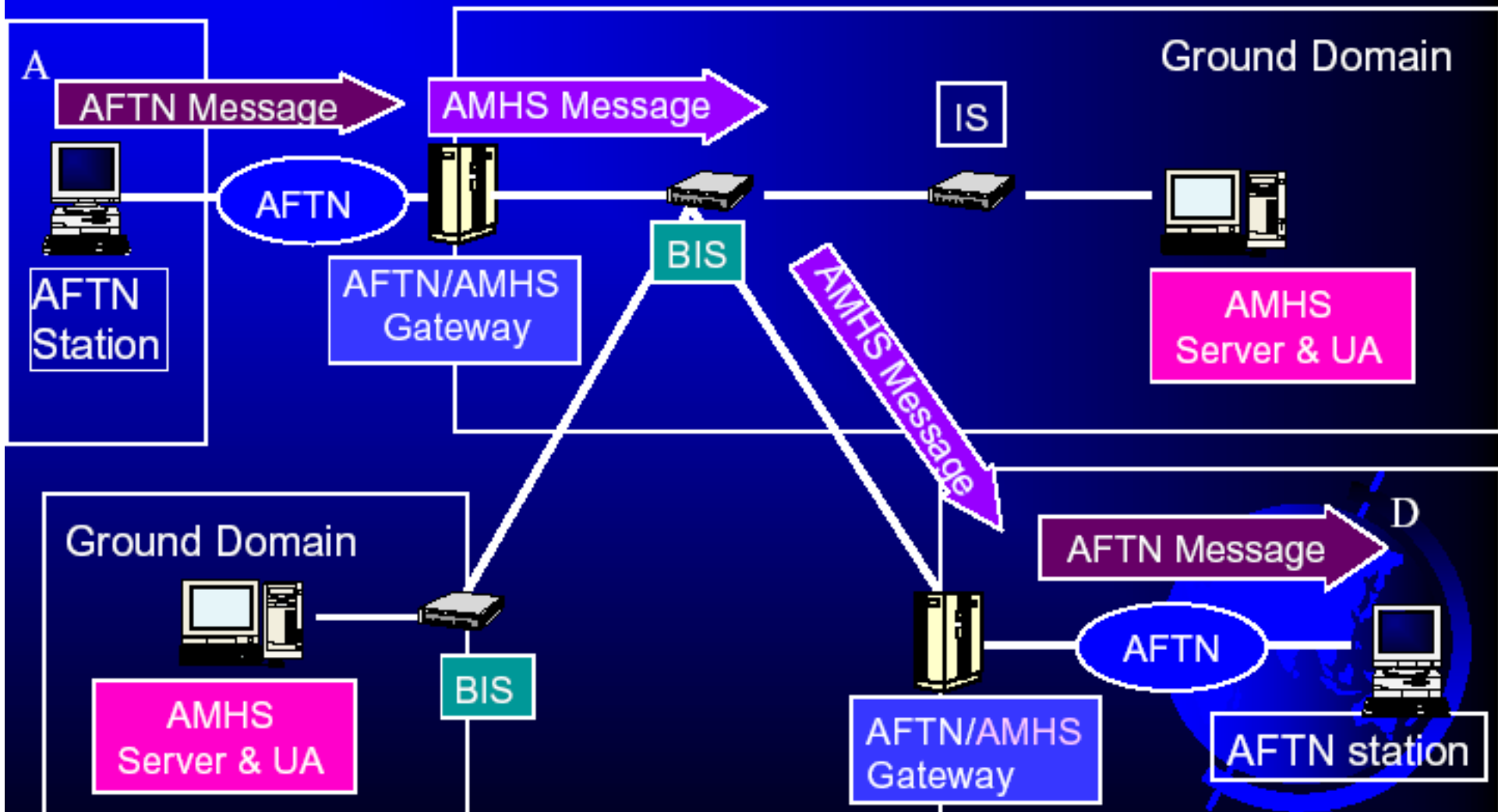



International Civil Aviation Organization

Questions?



International Civil Aviation Organization

Thank you