

Airbus Prosky
Thomas Bernstein

GNSS and PBN Generalities

ICAO AFPP Workshop
Nairobi
3rd – 6th November 2015



GNSS and PBN Generalities

Why GNSS ?

How does it work ?

GNSS augmentation means and associated approach types

PBN Generalities

Conclusion

Why GNSS

Navigation & GNSS History and
Concept





Navigation History

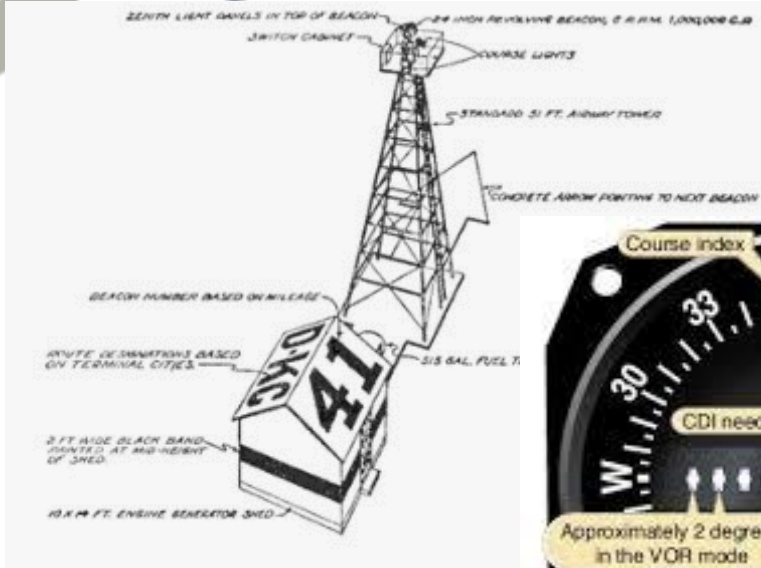

Figure 15-29. VOR indicator.



Navigation History



Visual References (Stars...)

Instrument landing System: **1938**

VOR (Airways): **1960s**

Introduction of 2D RNAV VOR/DME: **1975**

GPS navigation: **1994** RNP: **1996**

PBN ICAO mandate: **2016**

**Nav aids not always suitable in terrain challenging environment
and expensive to maintain**

Some History



Sputnik - **1957**

First GPS (Block 1) launch - **1978**

USA President Reagan makes GPS widely available - **1983**

GPS SA turned off – **2000**

PBN ICAO mandate: **2016**

Ground based NavAids do not provide coverage and accuracy needed for todays airspace.

Some History



Sputnik - **1957**

First GPS (Block 1) launch - **1978**

- ❑ Selective Availability (SA) was an intentional degradation of public GPS signals implemented for US national security reasons.
- ❑ In May 2000, at the direction of President Bill Clinton, the U.S government discontinued its use of Selective Availability in order to make GPS more responsive to civil and commercial users worldwide.
- ❑ The United States has no intent to ever use Selective Availability again

ICAO Annex 10 definitions

ICAO ANNEX 10

GNSS: Global Navigation Satellite System

A worldwide position and time determination system that includes one or more ***satellite constellations, aircraft receivers*** and system integrity monitoring, ***augmented*** as necessary to support the required navigation performance for the intended operation.

GPS: Global positioning system

The satellite navigation system operated by the United States.

GPS (Global Positioning System)

**Accuracy
of 10
meters or
better**

**Worldwide
coverage**

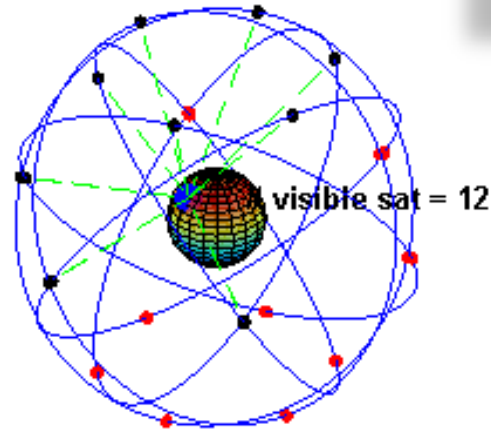

**Usable all
phases of
flight**

- Position computed in WGS84
- A 24* minimum satellite constellation into 6 orbital planes
- Mass market GPS receiver are not expensive

* USA engagement on the minimal GPS constellation

More GNSS

- GPS - 31 satellites
- BeiDou-2 (COMPASS) – 2020 with 30 satellites
- Galileo – 10 in orbit (2020 full operation (30))
- India – IRNSS regional first launch 1 JUL 2013
- GLONASS – 24 satellites 1995 / 26 APR 2013

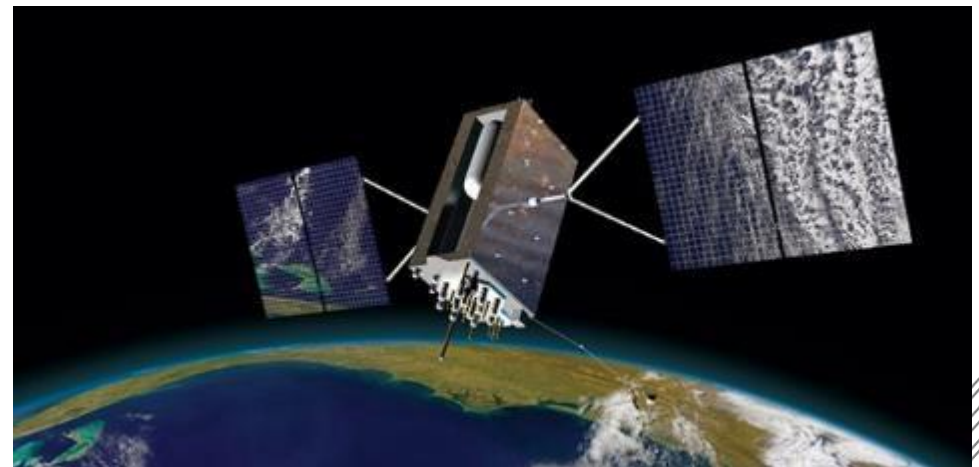
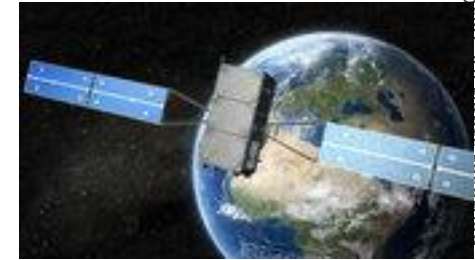

How it works?

GNSS concept



PVT computation

GPS SUPPLIED DATA:

The GPS is a system combining space, ground based and airborne segments which provides, with a worldwide coverage, 3D position (with respect to an Earth Centered Earth Fixed referential), velocity, and time

- **Space (Satellites)**
- **Ground (Control Stations)**
- **Airborne (Receiver)**

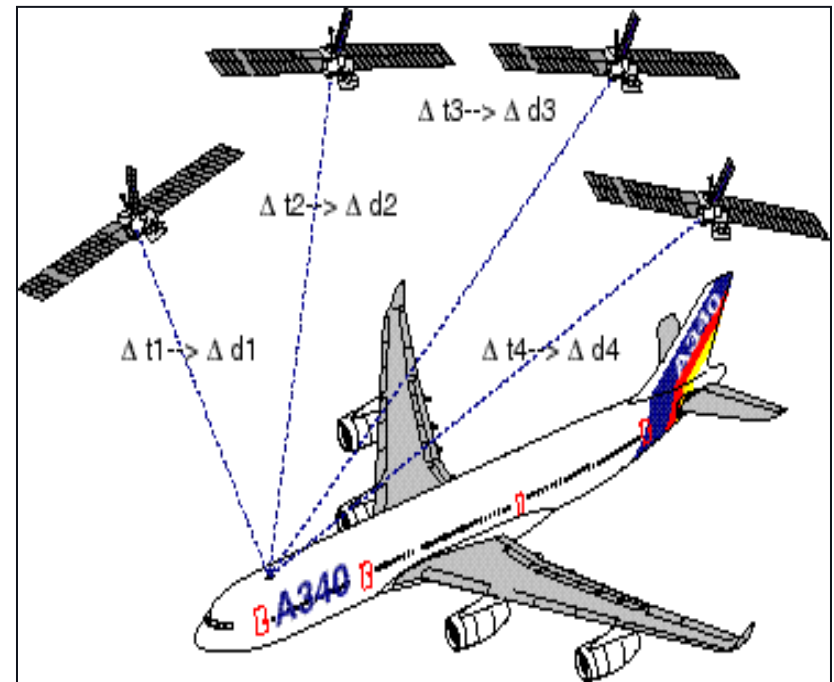

PVT (Position Velocity Time) determination by triangulation after propagation delay measurement

Basic Principles



- GPS is available worldwide
- GPS basis is the triangulation by satellites
- 4 satellites necessary to compute a position (x,y,z position and time solution)
- Precise position and time of each received satellite has to be known by the receiver

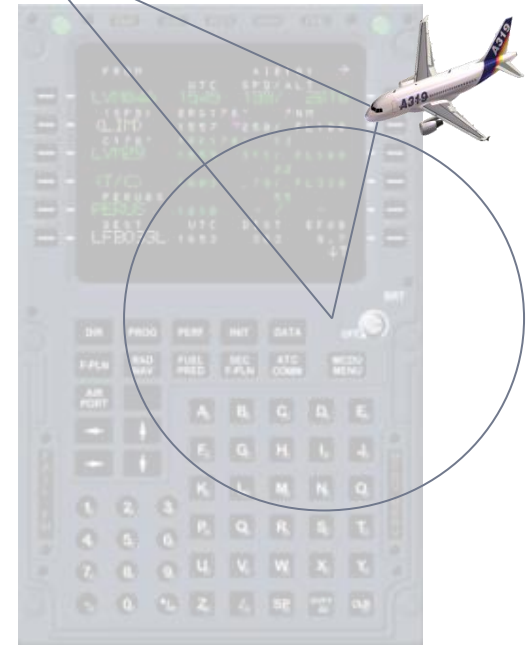

Positioning : GNSS

A, B & C are satellites

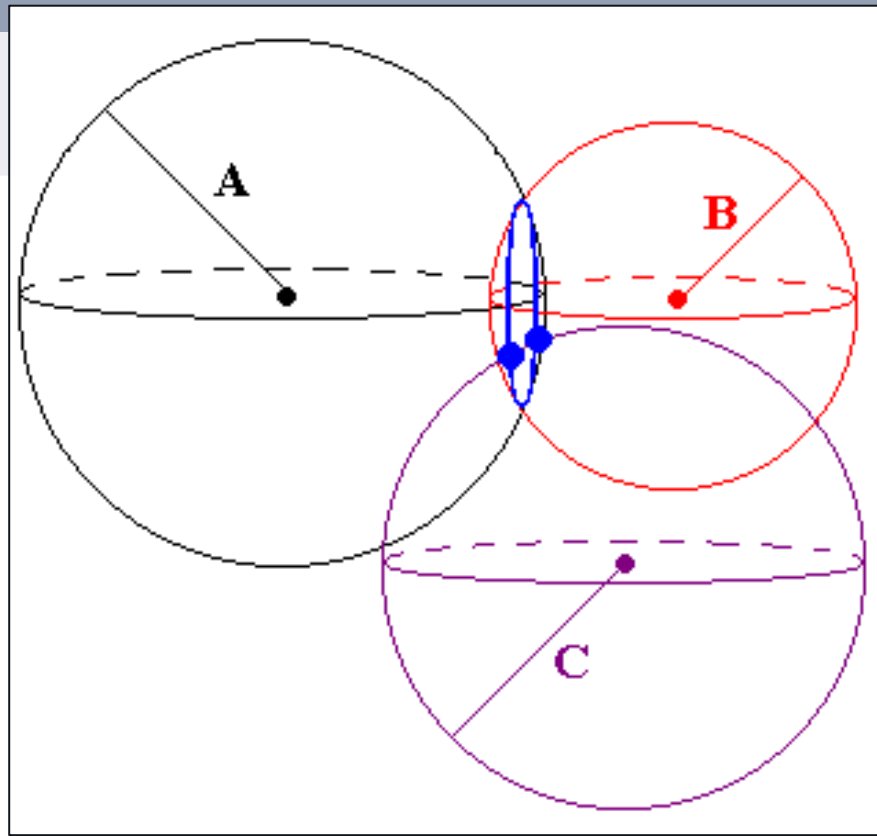

- **3 unknowns: Position (x, y, z)**
- **Intersection of 3 spheres : Gives 2 positions**
- **1 uncertainty (2 intersection points) → need 4 satellites to solve the equation**
- **Can be resolved with 4 equations, using Pseudoranges (distance satellite to antenna)**

GPS Positioning

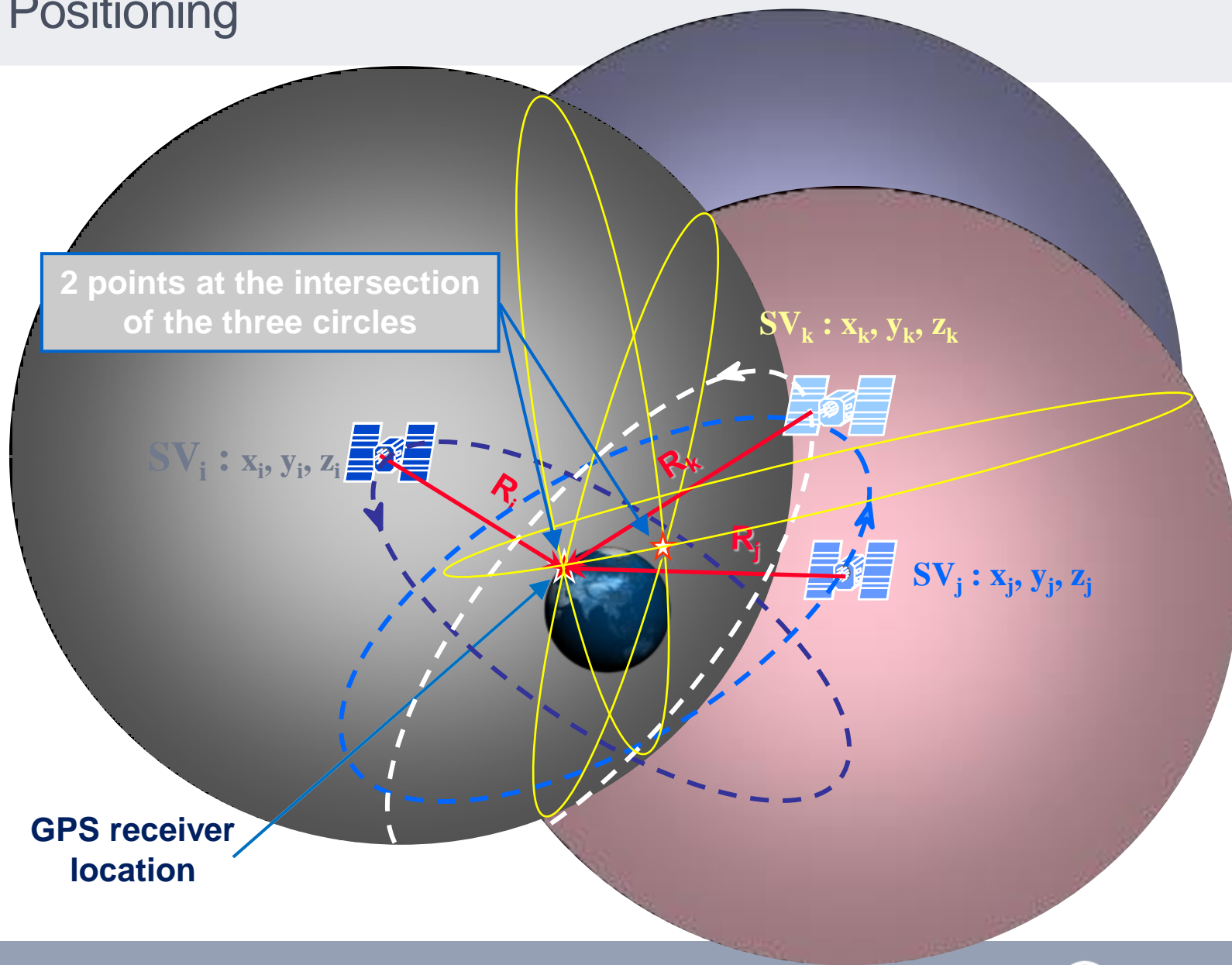

Ground segment: CONTROL SEGMENT

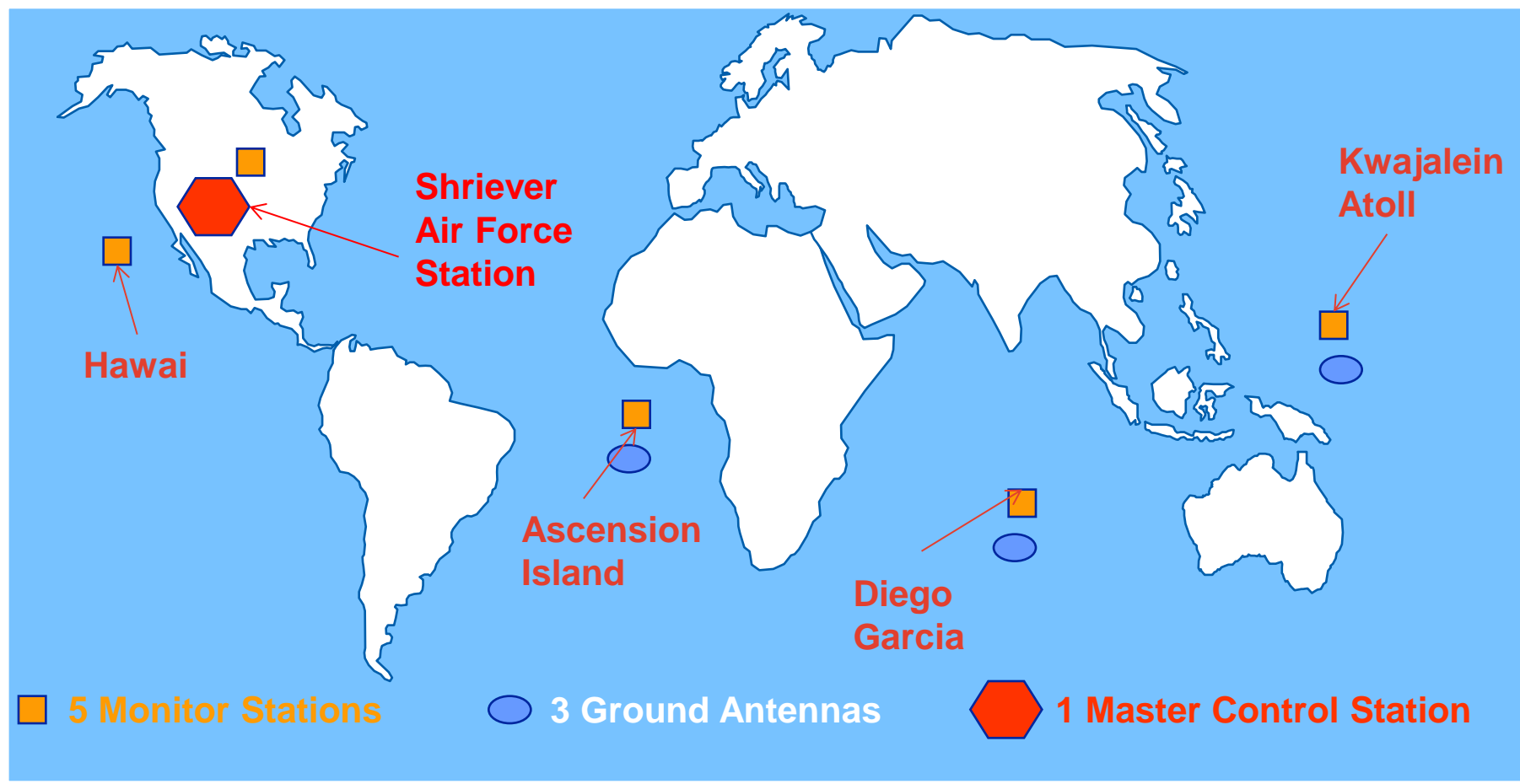

Requirements

In order to guarantee Signal In Space (SIS) for safe and reliable operations, four parameters are used:

Integrity

Accuracy

Availability

Continuity



ICAO Annex 10 Definitions

Integrity:

A measure of the **trust** that can be placed in the correctness of the information supplied by the total system.

Includes the ability of a system to provide **timely and valid** warnings to the user (**alerts**).

Accuracy:

GNSS position error is the difference between the **estimated** position and the **actual** position. For an estimated position at a specific location, the probability should be at least **95 per cent** that the position error is within the **accuracy requirement**.

ICAO annex 10 Definitions

Continuity :

Continuity of service of a system is the capability of the system to perform its function without ***unscheduled*** interruptions during the intended operation.

Availability :

Availability of GNSS is characterized by the portion of time the system is to be used for navigation during which reliable navigation information is presented to the crew, autopilot, or other system managing the flight of the aircraft.

GNSS Augmentation Means and Signal prediction



Can I trust this position ?



A need to trust “SIS” for safe operation

GPS

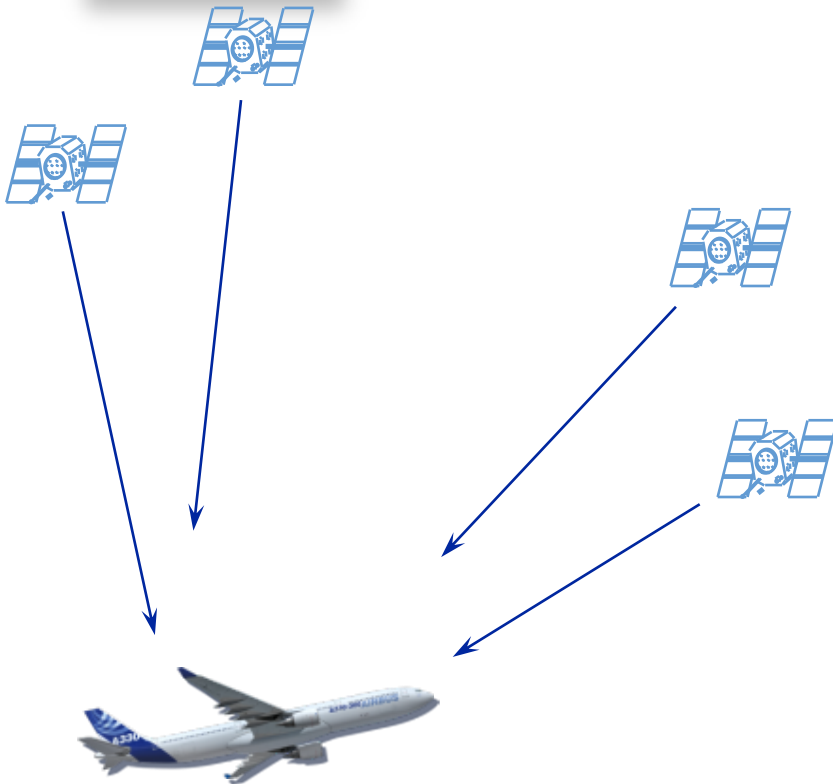

Satellites may broadcast

- ✓ Erroneous signal for hours
- ✓ Distance errors

Erroneous clock or ephemeris data

- ✓ Positioning errors

Users needs

- ✓ To know quality of computed position
- ✓ To be warned if anything goes wrong

This is checking integrity of SIS

A need to trust “SIS” for safe operation

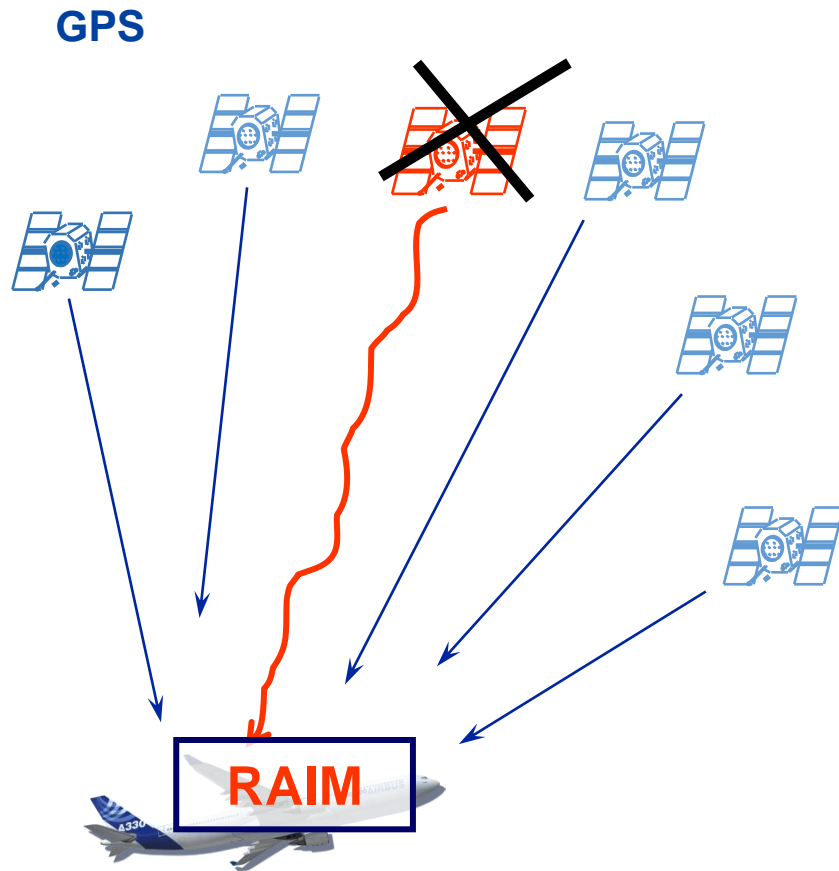

- ✓ 4 satellites to determine 3D position and time
- ✓ Usually more satellite are available (6 to 12)
- ✓ RAIM uses
 - 5 satellites for fault detection (FD)
 - 6 satellites for fault detection and exclusion (FDE)
- ✓ RAIM provides integrity and warning

RAIM on board function to guarantee integrity

GNSS integrity monitoring

- GNSS integrity monitoring techniques aim at monitoring the quality of GNSS positioning
- Large variety of techniques:
 - ❖ In an autonomous manner (ABAS) :
 - Using the redundancy of GNSS measurements only (RAIM)
 - ❖ Using a ground station (GBAS)
 - ❖ Using a network of ground stations (SBAS)
- All these systems can include Fault Detection (FD) or Fault Detection and Exclusion (FDE)

Other Augmentations

- ✓ Complements the core satellite constellation(s) by increasing quality of positioning

- ✓ Through space segment and ground segment : SBAS
 - WAAS, EGNOS, MSAS, GAGAN, COMPASS
 - Area service including multiple aerodrome

- ✓ Through ground segment : GBAS
 - Multiple companies develop versions of GBAS

Availability of Autonomous Integrity

- ✓ Depends on phase of flight
 - Better in En Route than in Approach

- ✓ Can be predicted based on satellite almanac data at a specific location and time
 - Predictions tools

- ✓ RAIM/ABAS is not sufficient for APV (Except Baro VNAV) or Precision Approach operations

GNSS based Approach types

SLS (SBAS)

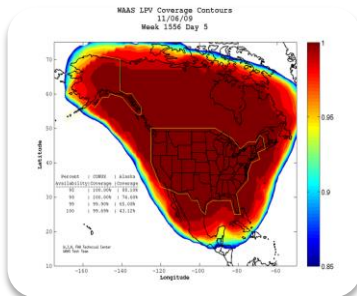

- Approach with Vertical Guidance based on augmented GPS
- Significant investment in ground & space infrastructure required : WAAS in the US, EGNOS in Europe, GAGAN...
- Airbus (except A350 XWB) and Boeing fleet not yet capable
- Minima down to 200ft AGL, Straight-in approaches (ILS like)

GLS (GBAS)

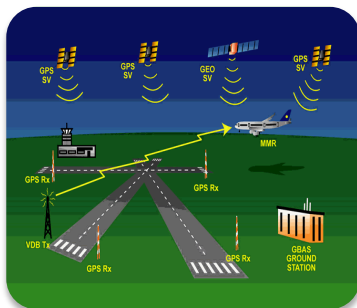

- Precision Approach (currently CAT I, CAT II/III under study, not before 2017)
- Lateral and vertical guidance to a Decision Altitude
- Ground station required
- Straight-in approaches (ILS like)

RNP (ABAS)

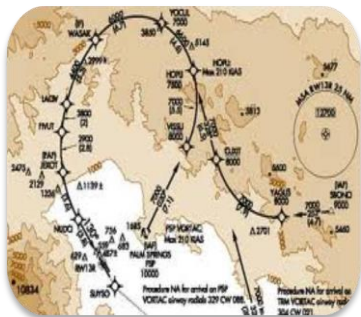

- Non Precision Approach : RNP APCH & RNP AR APCH
- Based on GNSS (Lateral) & Baro VNAV (Vertical Guidance)
- No ground infrastructure required
- Most aircraft capable
- Minima down to 250ft AGL, down to a Decision Altitude with Baro VNAV



SBAS COVERAGE

© Airbus Pr

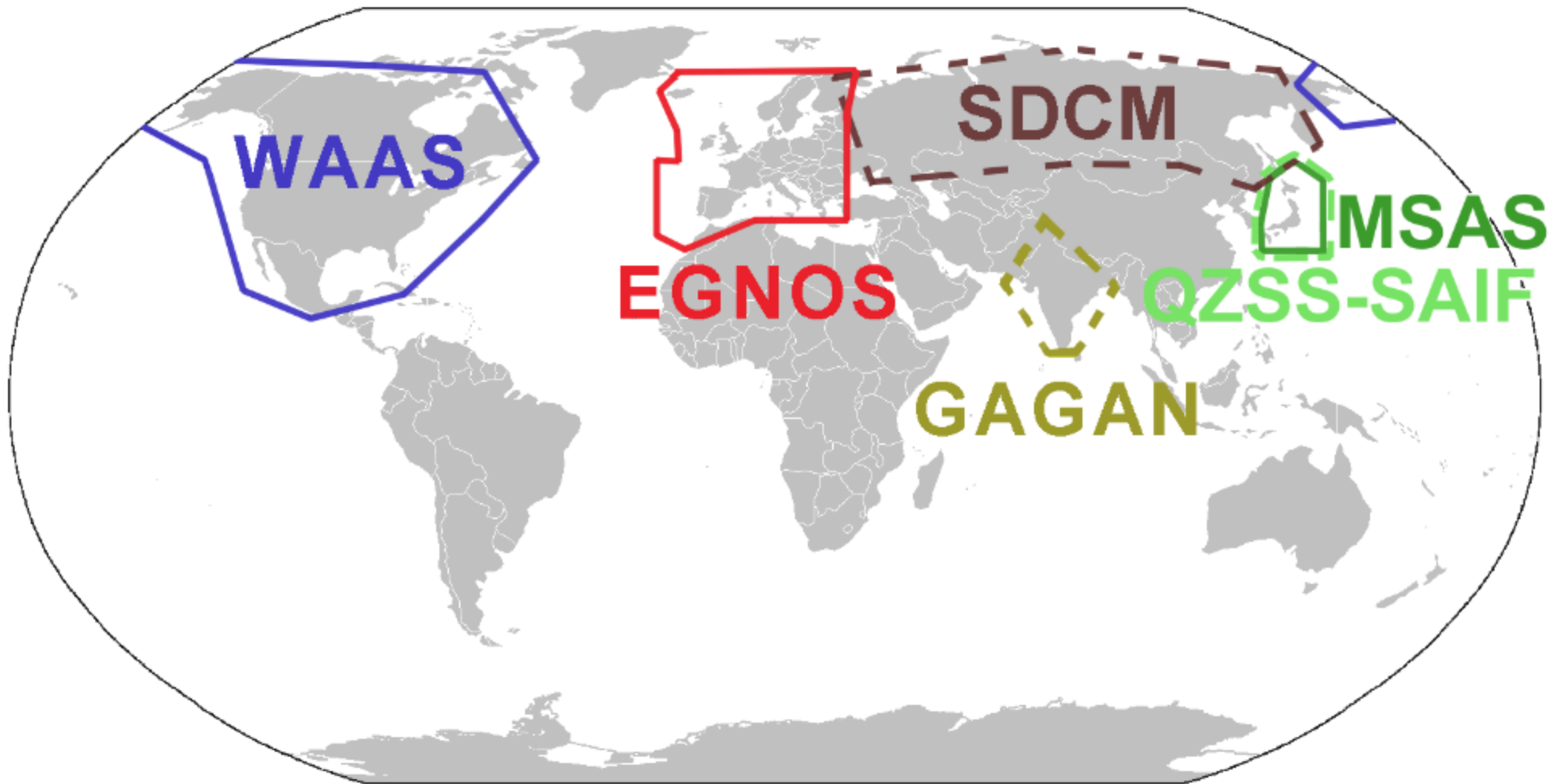



SBAS - WAAS

Current WAAS RNP 0.3 Navigation Service Display

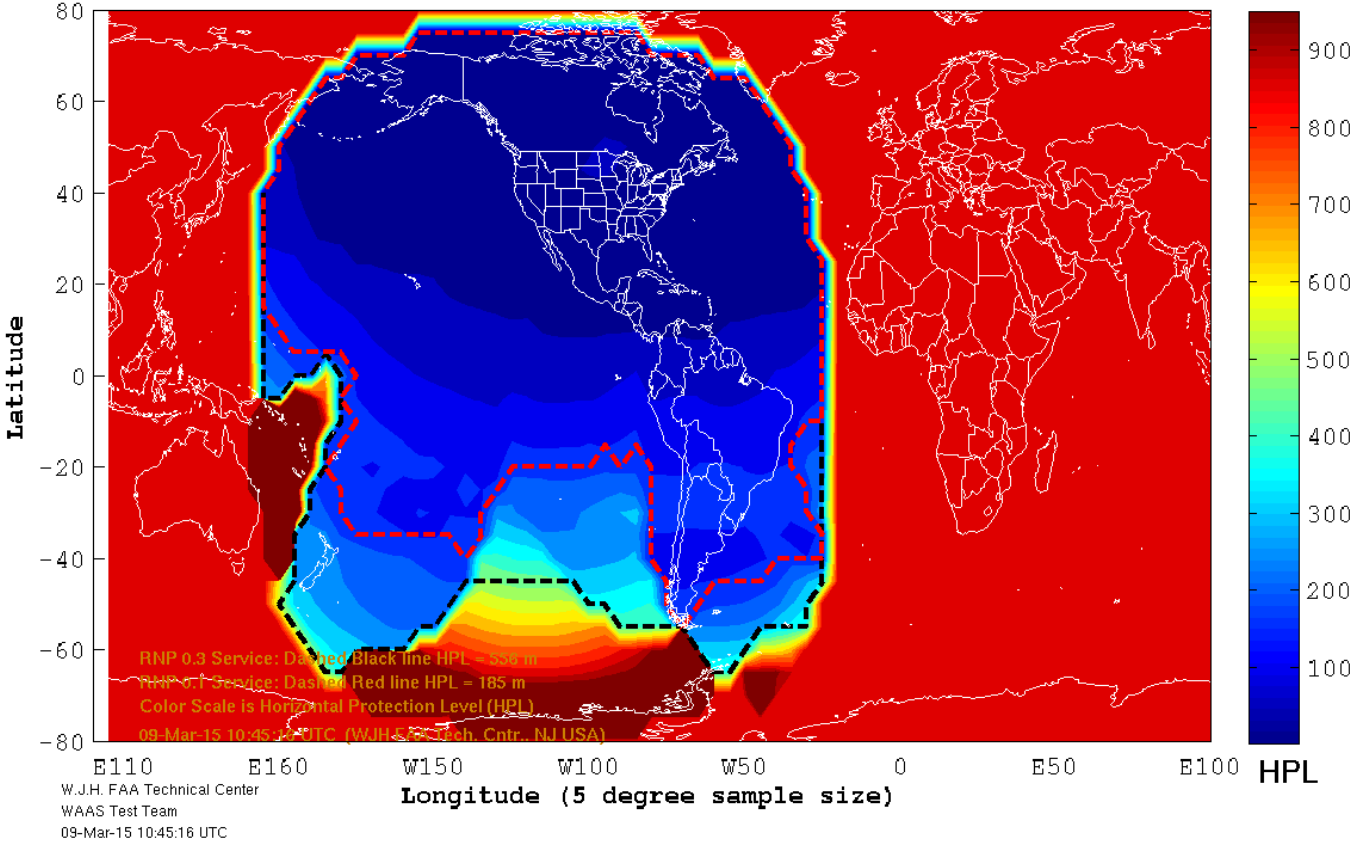

GBAS Architecture

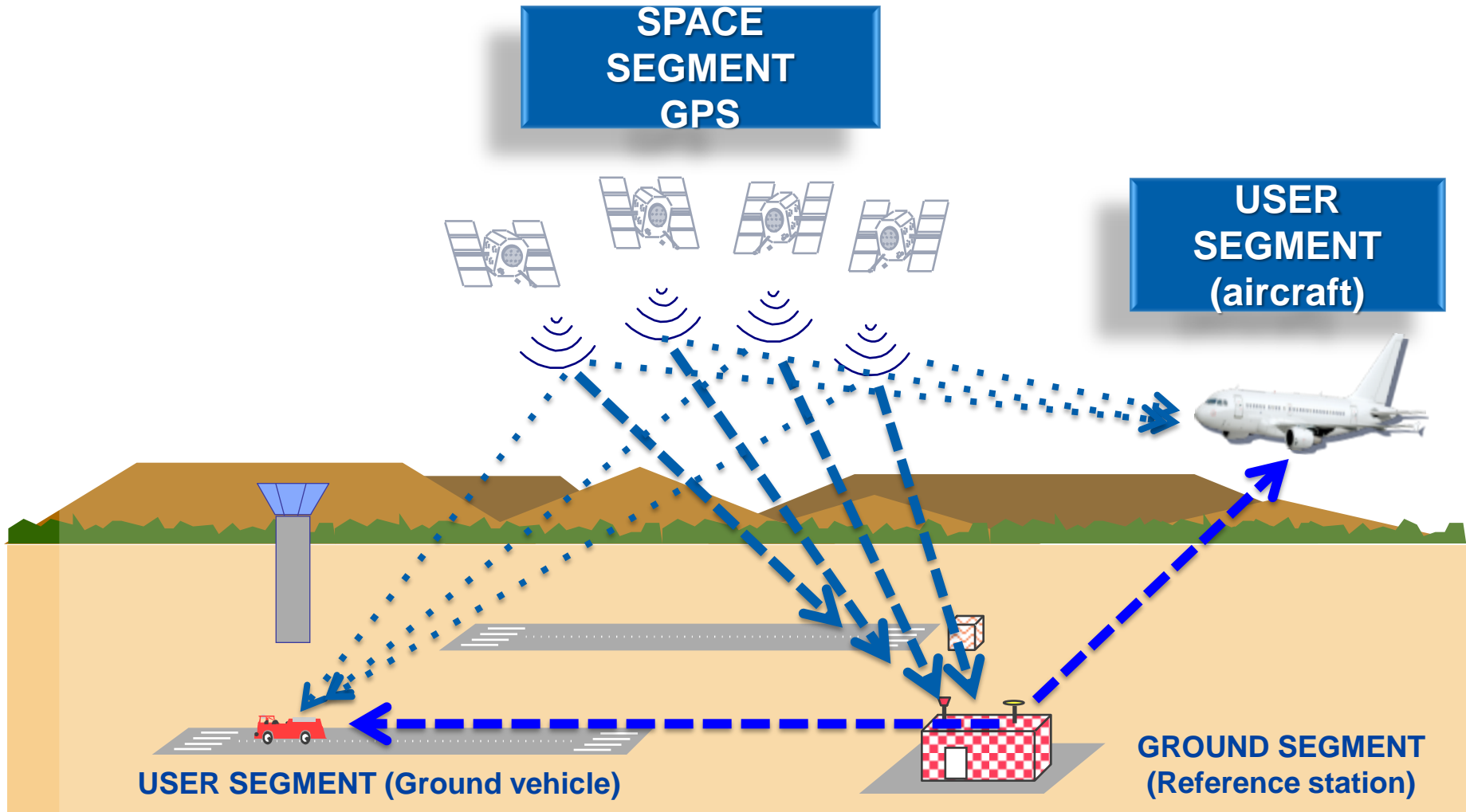

Positioning Error and Errors Analysis

Unlike *ILS and VOR*, GNSS errors change over time :

- ✓ The orbiting of satellites
- ✓ The error characteristics of GNSS
- ✓ The satellite geometry

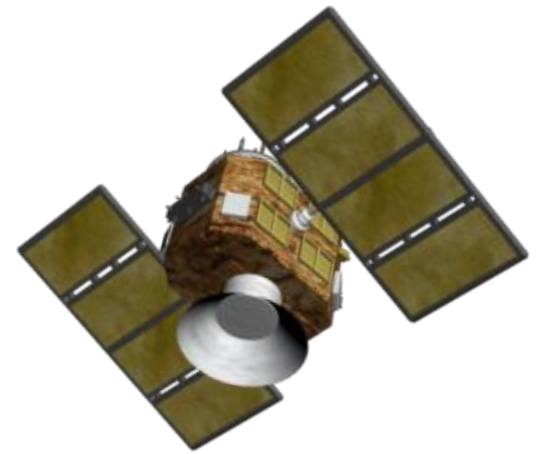

For GNSS

- ✓ Position errors can change over a period of hours
- ✓ But high level of reliance on analysis and characterization of errors.

GPS Prediction Tools

- Based on constellation status information issued by US Coast Guard
- Assessment of availability and continuity
- Based on RAIM concept
- More or less sophisticated
 - ✓ Include one or more points (2D or 3D)
 - ✓ Include or not mask due to terrain

PBN Generalities





WHY PBN

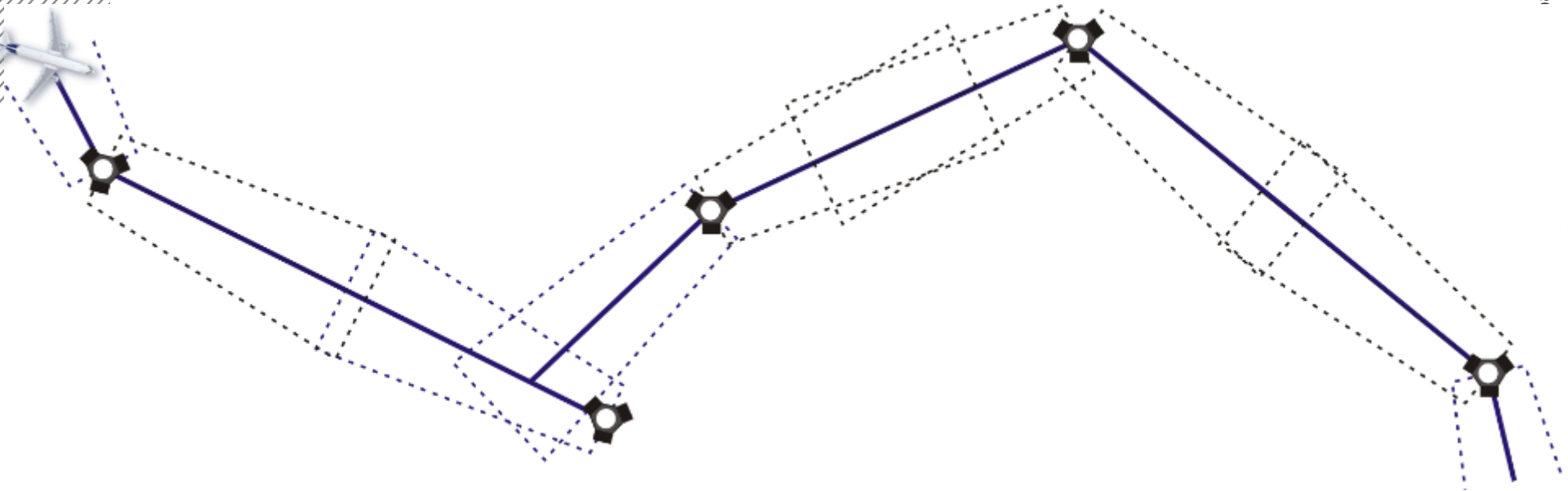

Conventional Route Following VOR's



WHY PBN

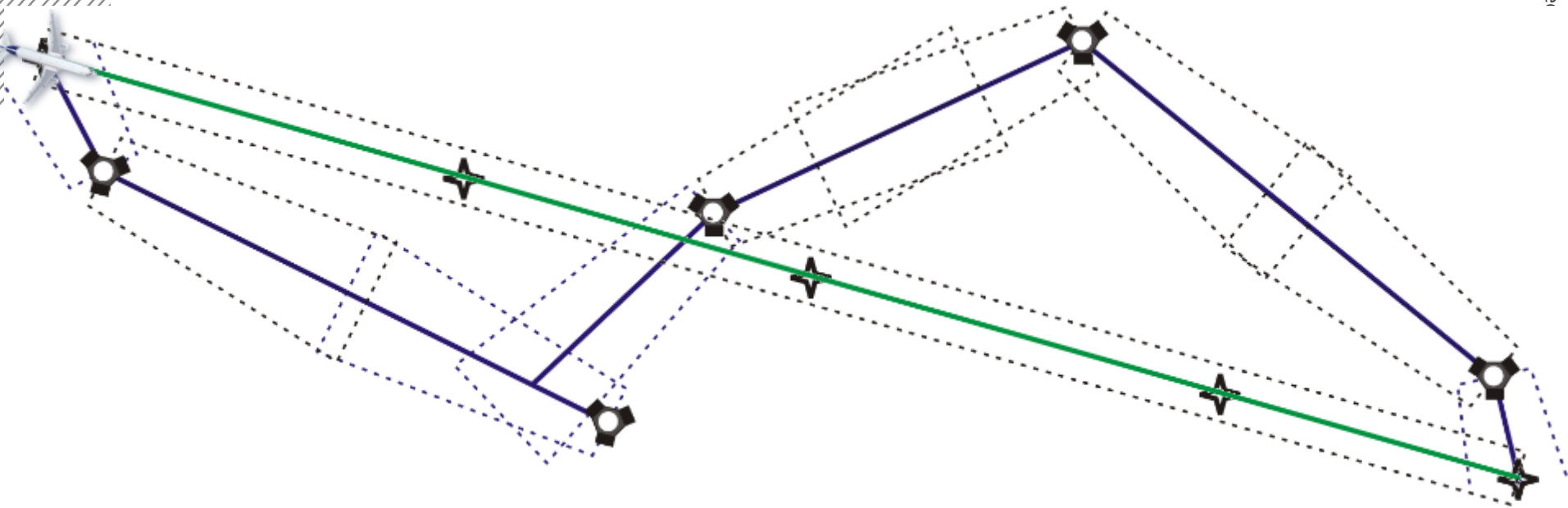

PBN Route Using Waypoints

Conventional routes

- **Defined based on old aircraft capabilities and use of conventional navigation means**
 - ✓ Large protection areas and separation criteria to cope with limited accuracy of position estimation
- **Based on Ground Navigation Aids**
 - ✓ Overfly
 - ✓ Relative position
- **Limited design flexibility**
 - ✓ Leading to traffic saturation

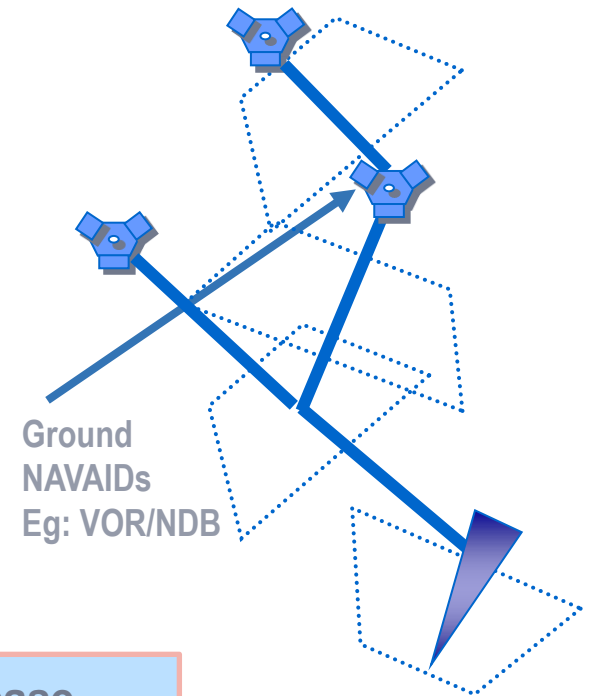

Widely used but no more suitable due to traffic increase
and high fuel cost

RNAV Definition

RNAV stands for **Area Navigation**

RNAV: Capability to fly any desired flight path, defined by waypoints such as geographic fixes (LAT/LONG) and not necessarily by ground nav aids

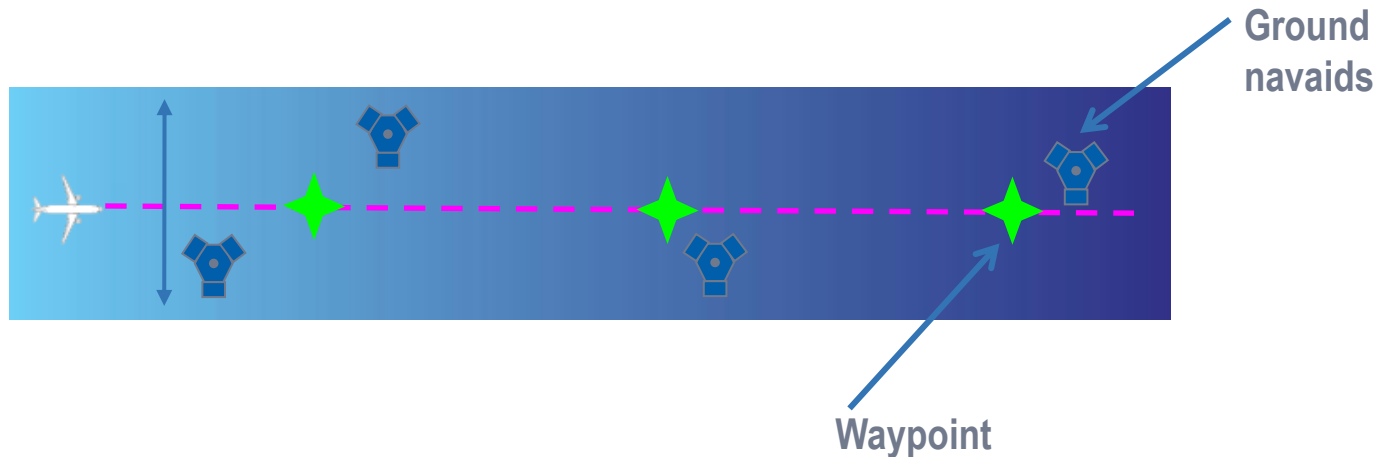

RNAV capability is linked to aircraft on-board equipment (RNAV systems)

“**RNAV X**” **capability** represents the linear lateral Accuracy of the Navigation system expected to be achieved 95% of the flight time

RNAV is a method of navigation allowing for the definition of more direct routes

RNAV SYSTEM: A/C Position

NAV mode

IRS drift



Available positions

PBN Predictability

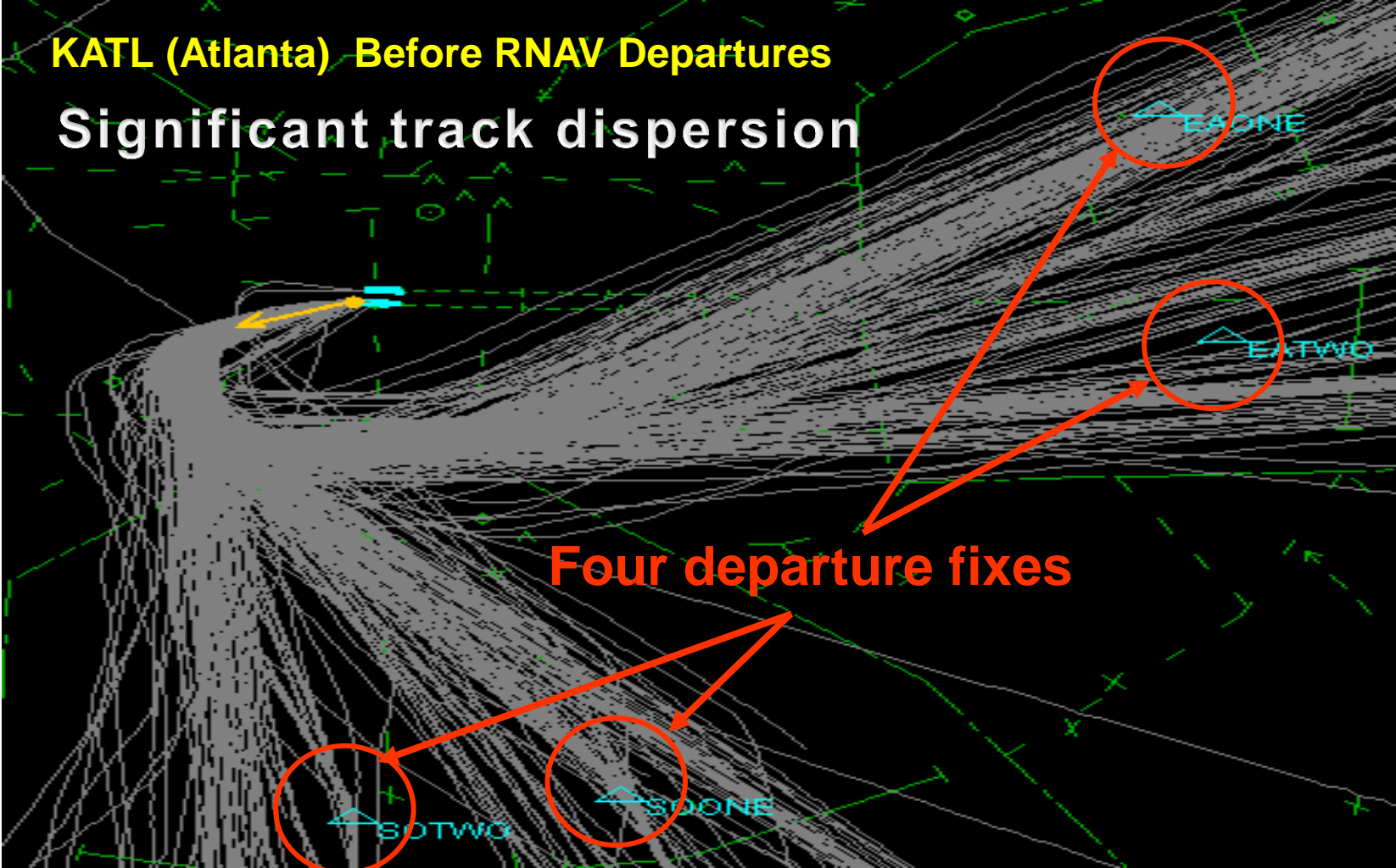

PBN Predictability

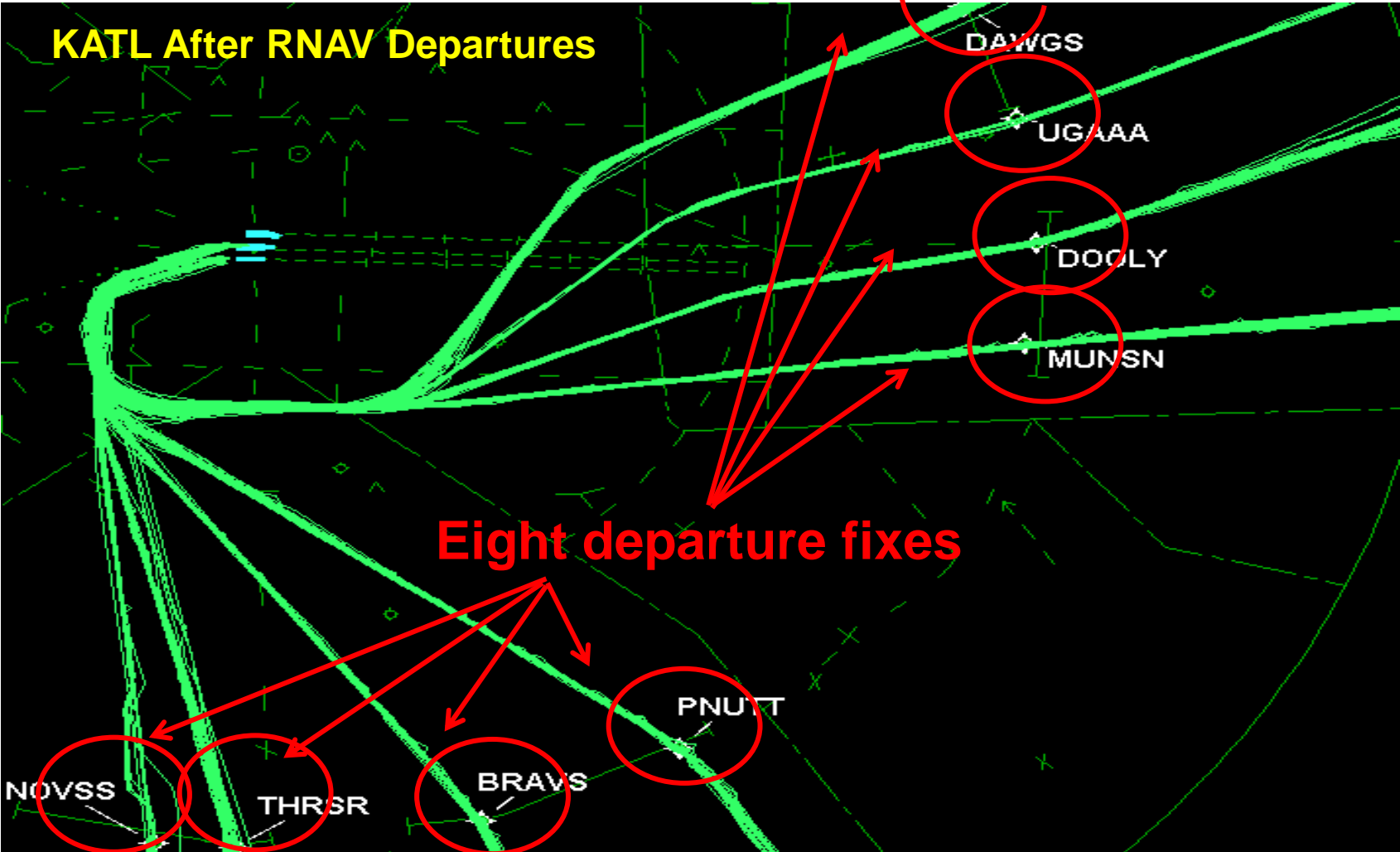

RNAV SYSTEM

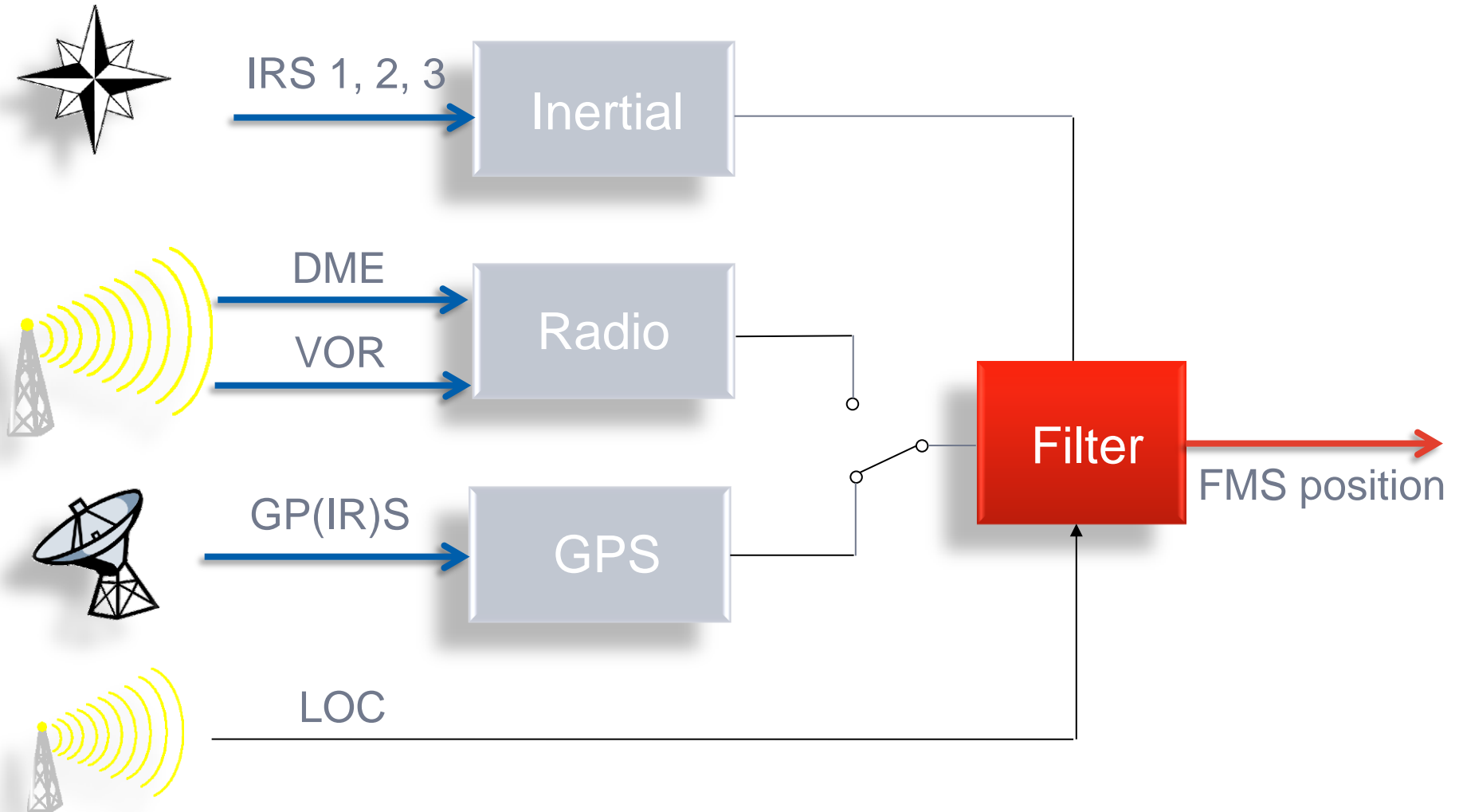

RNAV Operations

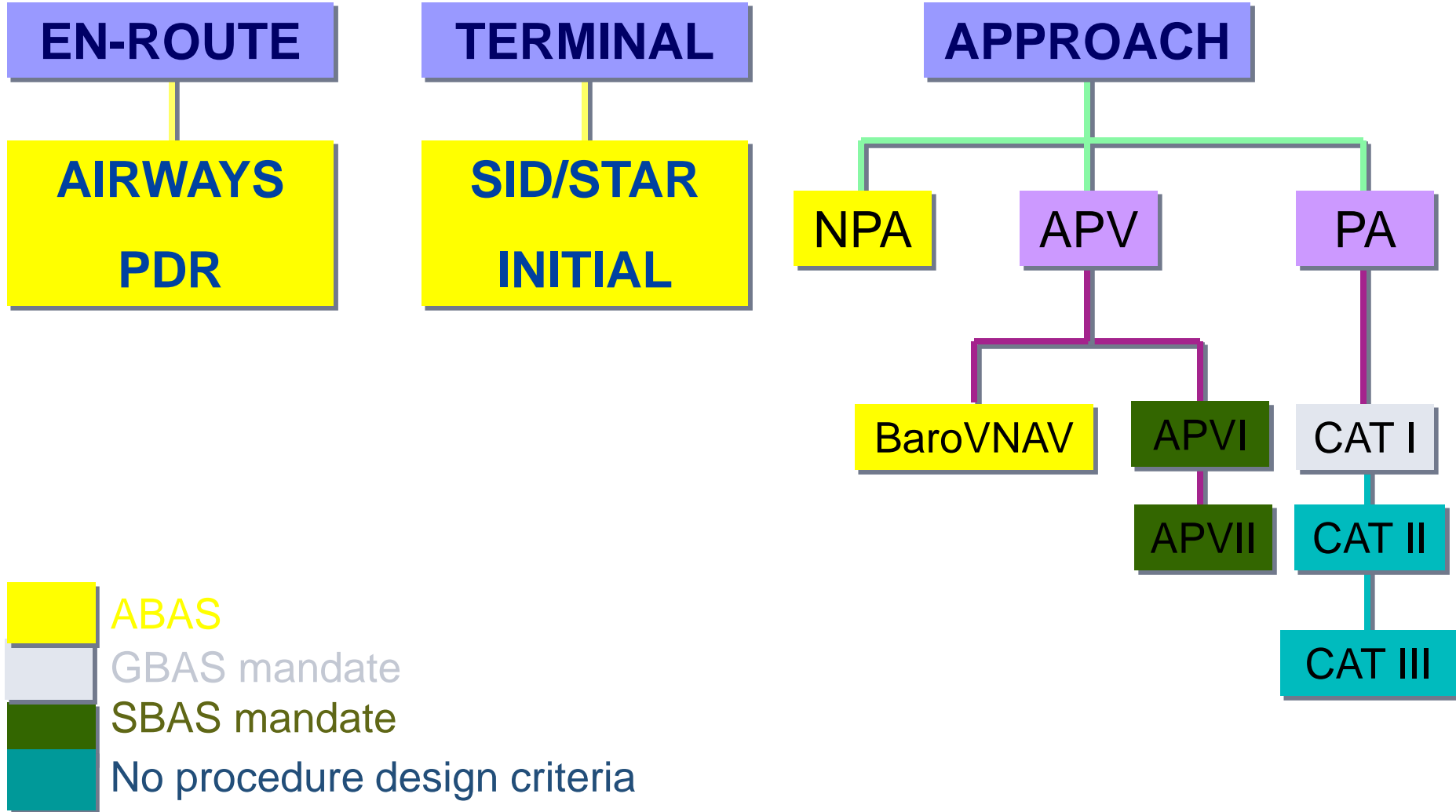

Performance Based Navigation implementation is strongly promoted by ICAO

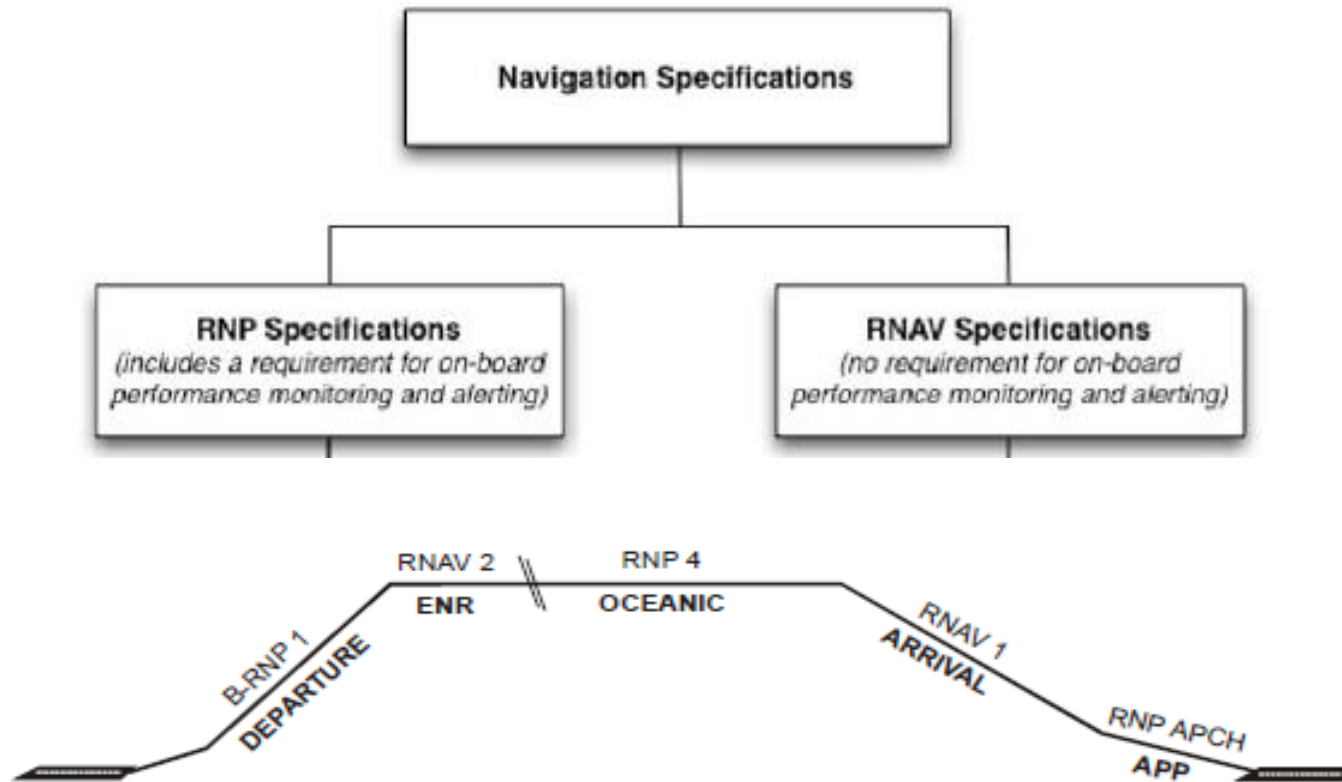

ICAO Resolution A36-11, urges States to implement by 2016 :

- ✓ Performance-Based Navigation (PBN)
- ✓ Approaches with Vertical Guidance (APV)

RNP ensures trajectory containment

$$\text{RNP} = \left\{ \begin{array}{l} \text{Navigation accuracy} \\ \text{On board containment integrity} \\ \text{Continuity of RNP capability} \end{array} \right\} + \text{On Board Performance Monitoring and Alerting (OBPMA)}$$

$$\text{RNP} = \text{RNAV} + \text{OBPMA}$$

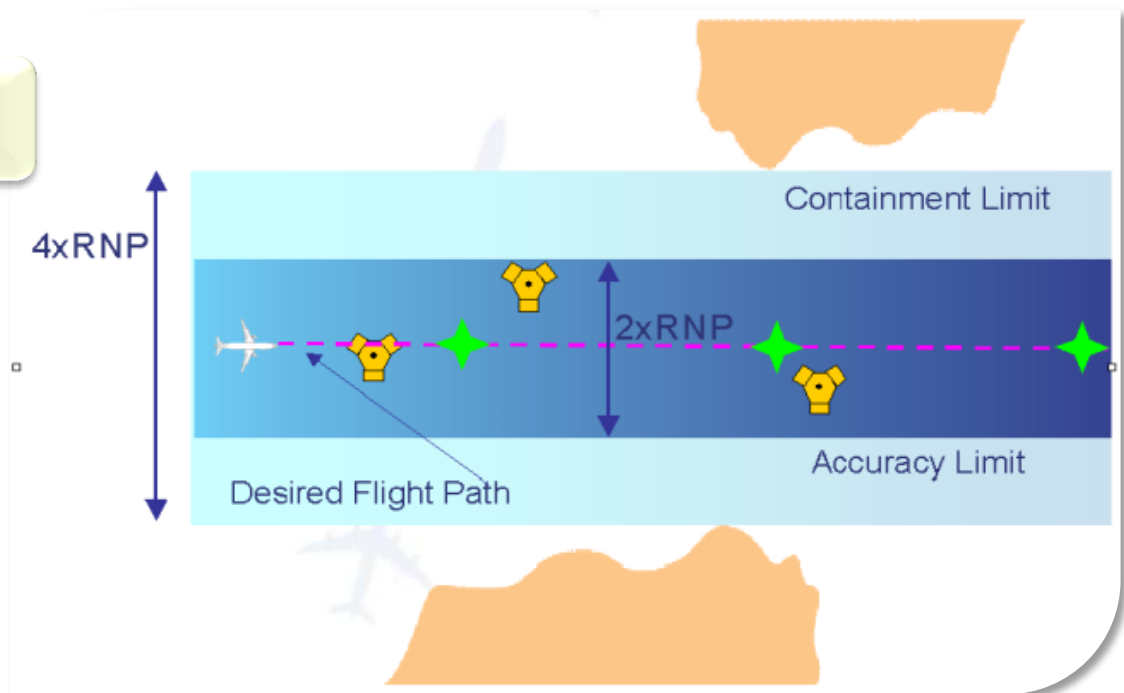

RNP X = +/- X NM corridor for the accuracy limit,
 +/- 2*X NM corridor for the containment limit

PBN concept

RNAV 1

No ALERT on board

Track Centerline

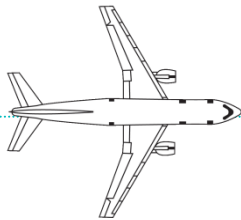

1 NM 95%

1 NM 95%

RNP 1

ALERT and Crew procedure

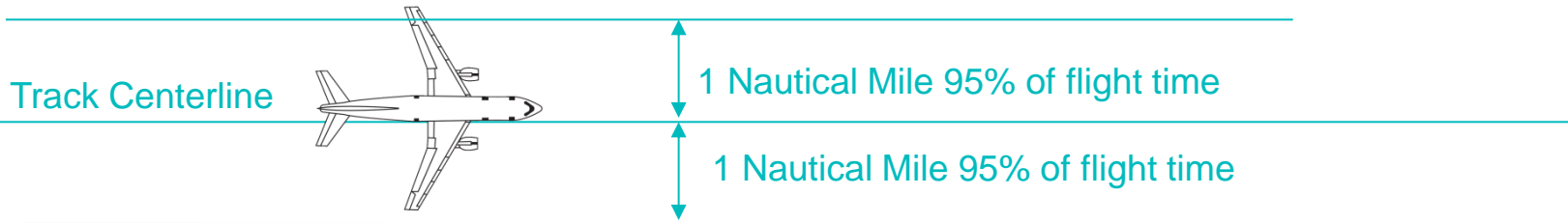

The Key difference

On-board performance Monitoring and alerting function

On-Board performance monitoring and alerting function

What is an On-board Performance Monitoring and Alerting (*OBPMA*) function ?

- A function on board the aircraft detecting and informing the crew when the RNAV system is unable to satisfy the performance prescribed in the ***navigation specification***
- This function should monitor all type of errors which may affect the aircraft ability to follow the desired flight path
- The required level of on board monitoring and alerting is stipulated in each RNP navigation specification.



RNP

RNP is RNAV with the additional requirement of On Board Performance Monitoring and Alerting

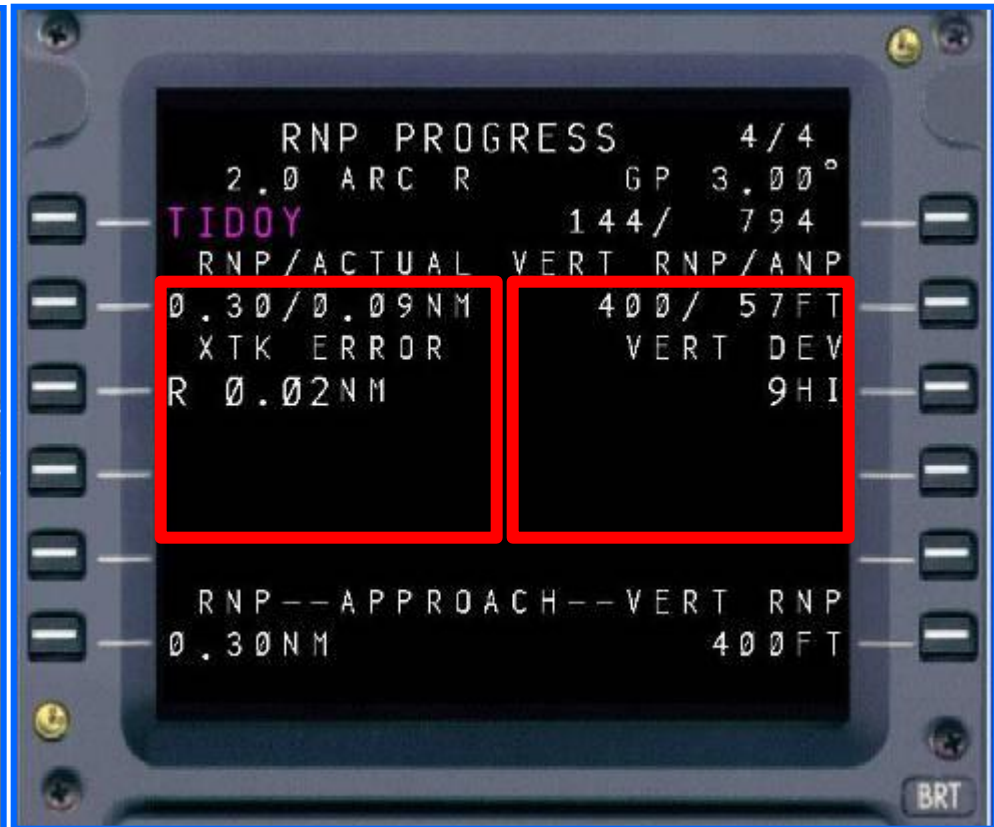

PBN Concept : Definitions

To NAVIGATE you need :

- A MAP, to define your trajectory
→ *Waypoints in NDB*
- To know where you are
→ *Position at A/C level thanks to IRS and GPS*
- To be Guided along the trajectory
→ *Guidance by FMS/AP or FD order provide to the crew*

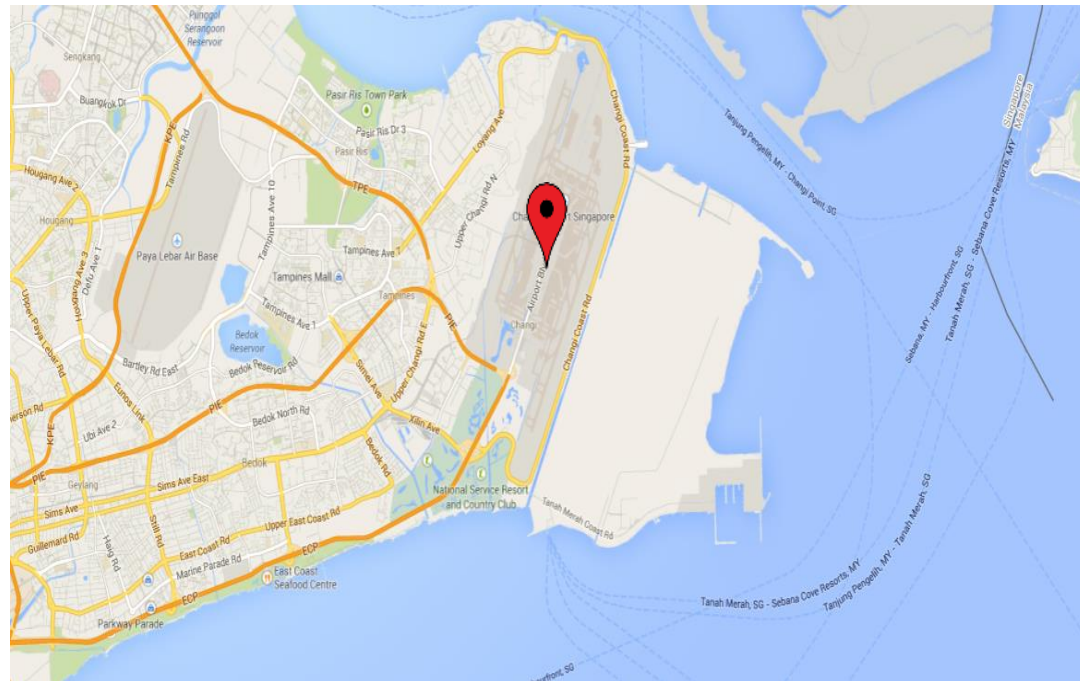

PBN Concept: Positioning

Position error
from:

- Path Computation
- +
 - Guidance : XTK error
- +
 - Position computation
- =
Total System Error

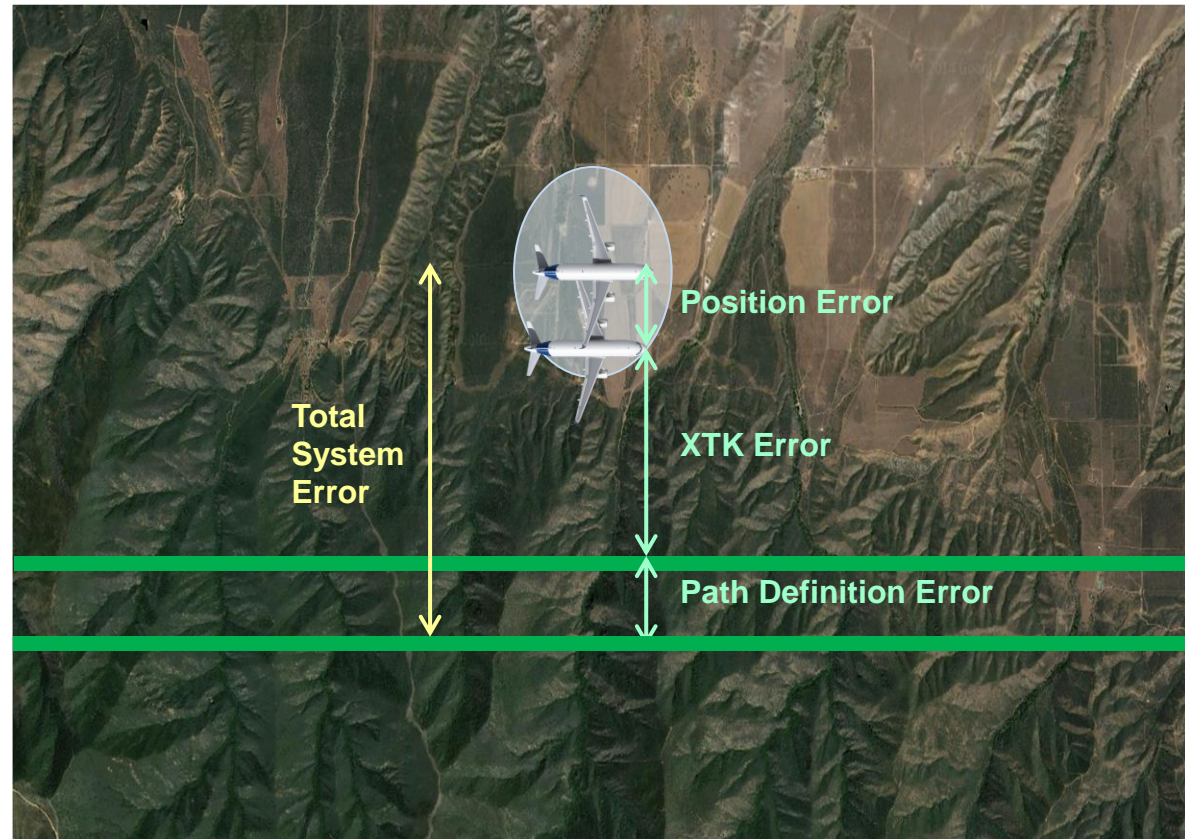

PBN Concept: Design of a RNP or RNAV procedure

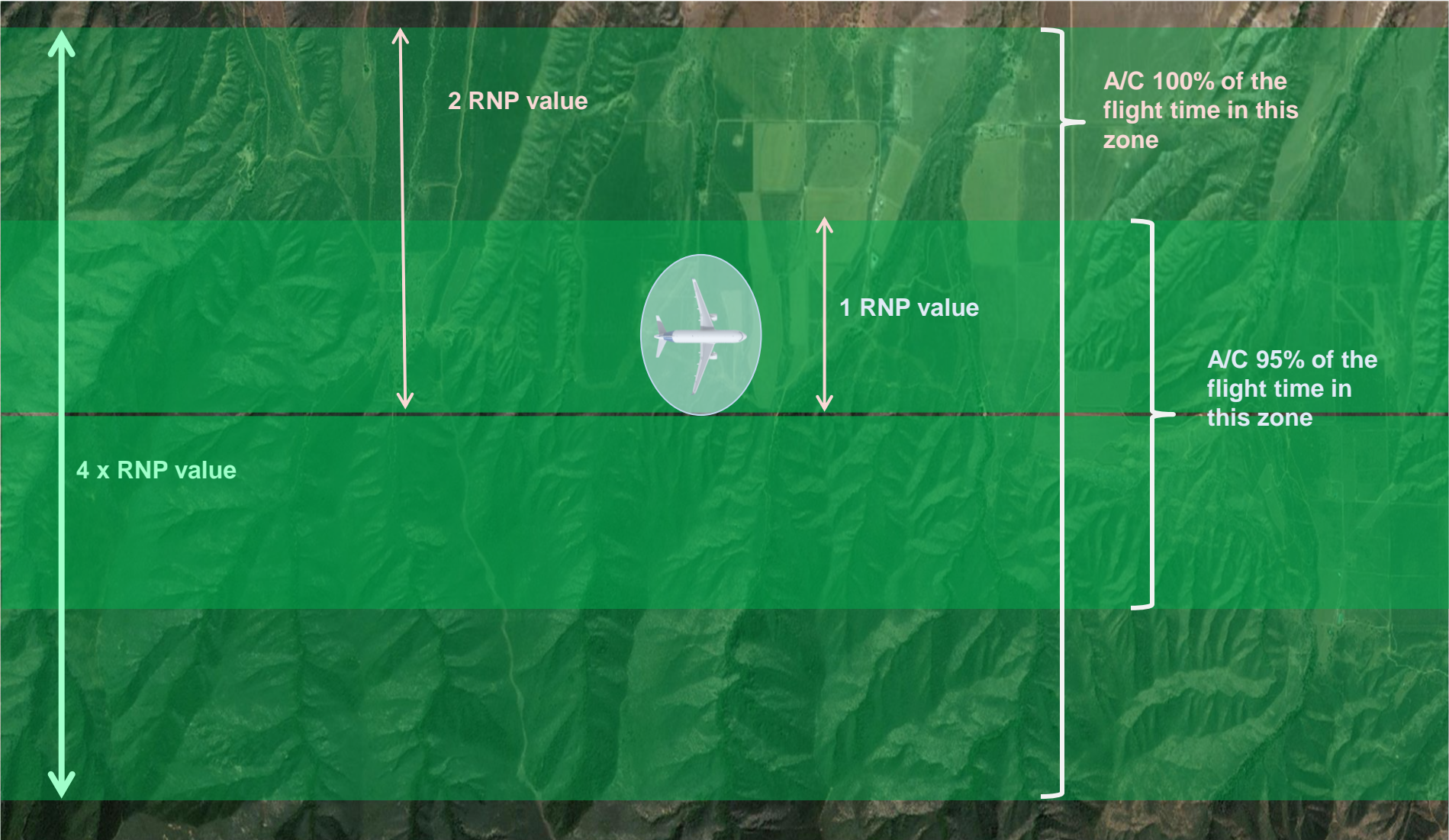

PBN Concept: Design of a RNP or RNAV procedure

- Corridor of 2 RNP each side of the A/C
- Buffers
- Outside this zone obstacle or other airspace are not taken into account

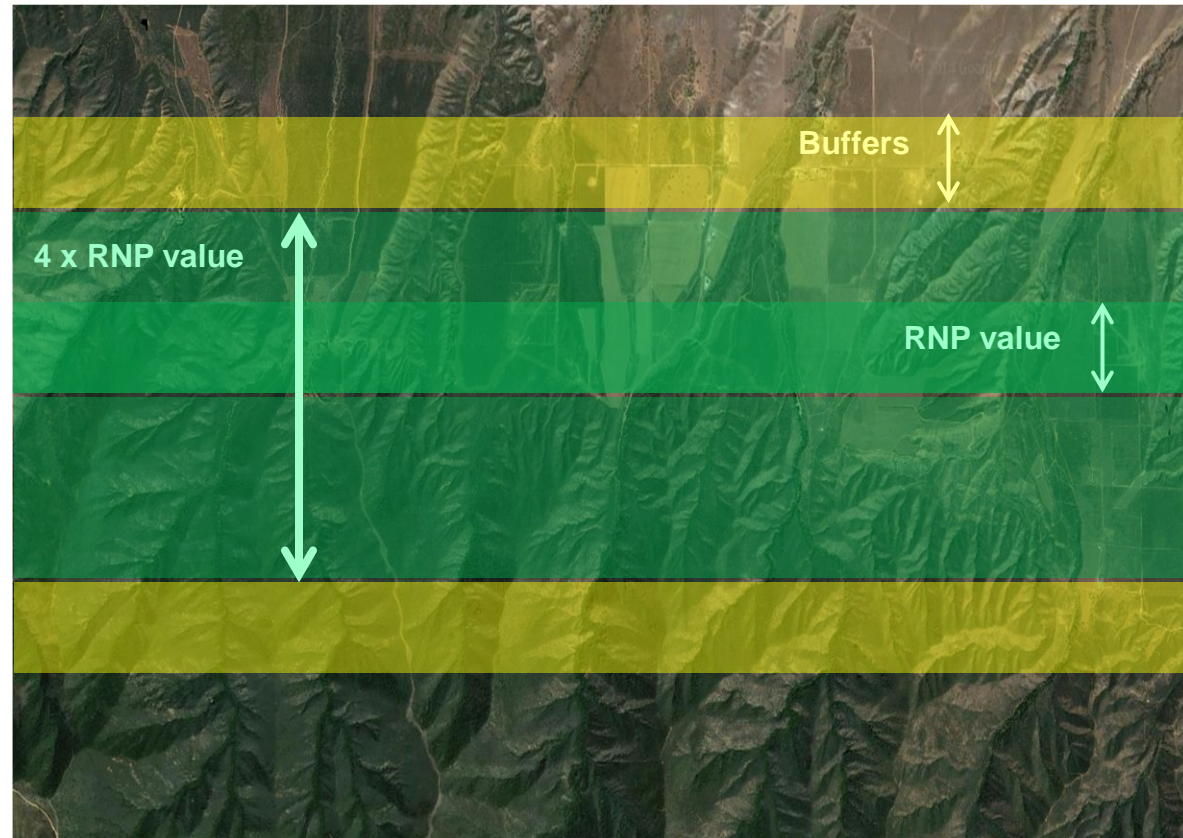

PBN Concept: RNP

- To be RNP capable, the FMS must monitor its navigation performance regarding the RNP value.
- It requests an On-Board Performance Monitoring and Alerting System.
- All Airbus A/C have an OBPMA

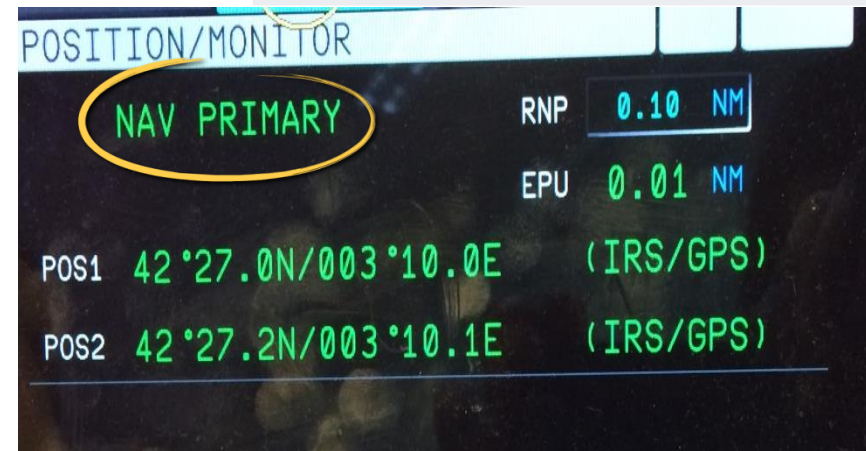

Navigation System Error (NSE)

- Difference between the actual position and the calculated position
- Takes into account:
 - Transmitted Signal error
 - Position calculation error

Flight Technical Error (FTE)

- Ability to follow the defined path
 - FTE in manual mode
 - FTE with the FD
 - FTE of the Autopilot
- Error depends on the flight phase (sensitivity of the deviation indicator, AP)

Flight Phase	Coupled		
	Manual (nm)	Flight Director (nm)	Autopilot (nm)
Oceanic	2.0	0.5	0.25
En Route	1.0	0.5	0.25
Terminal	1.0	0.5	0.25
Approach	0.5	0.25	0.125

FTE assumptions from RTCA DO 208 Appendix E

Path Definition Error (PDE)

- Errors between the desired path and the defined path
- WPTs coordinates in WGS 84
- Possible Error Source:
 - Errors in the defined coordinates of the WPT
 - Mis interpretation of the source by the data base encoder
 -
- PDE is managed through a quality process and development methodology in data processing
 - DO 200A
 - LOA Type 1 and 2
 -
- The end user is the operator
 - He has to assess that adequate development methodology has been applied
 - Crew procedures to check that what is encoded is what is published.

PBN Concept: Airbus A/C performances

- **PDE:** considered null (NDB well coded and verified)

- **XTK:** MONITOR BY THE CREW
upon AP less than 0.1NM most of the time



- **EPE:** MONITOR BY THE SYSTEM (OBPMA)
less than 0.08NM most of the time



4 RNP corridor to cover major critical failures



PBN – Flight Operations

PBN – Procedure Design

The new design criteria
need adapted SOPs*
* Standard Operating Procedures

MINIMUM LATERAL
OBSTACLE
CLEARANCE LIMIT

A **2xRNP** corridor represents the **Containment limit** for escape, free of obstacles.

OPERATIONAL
LIMIT

If LDEV or XTK reaches **1xRNP** (the **Operational limit**) an approach will be interrupted.

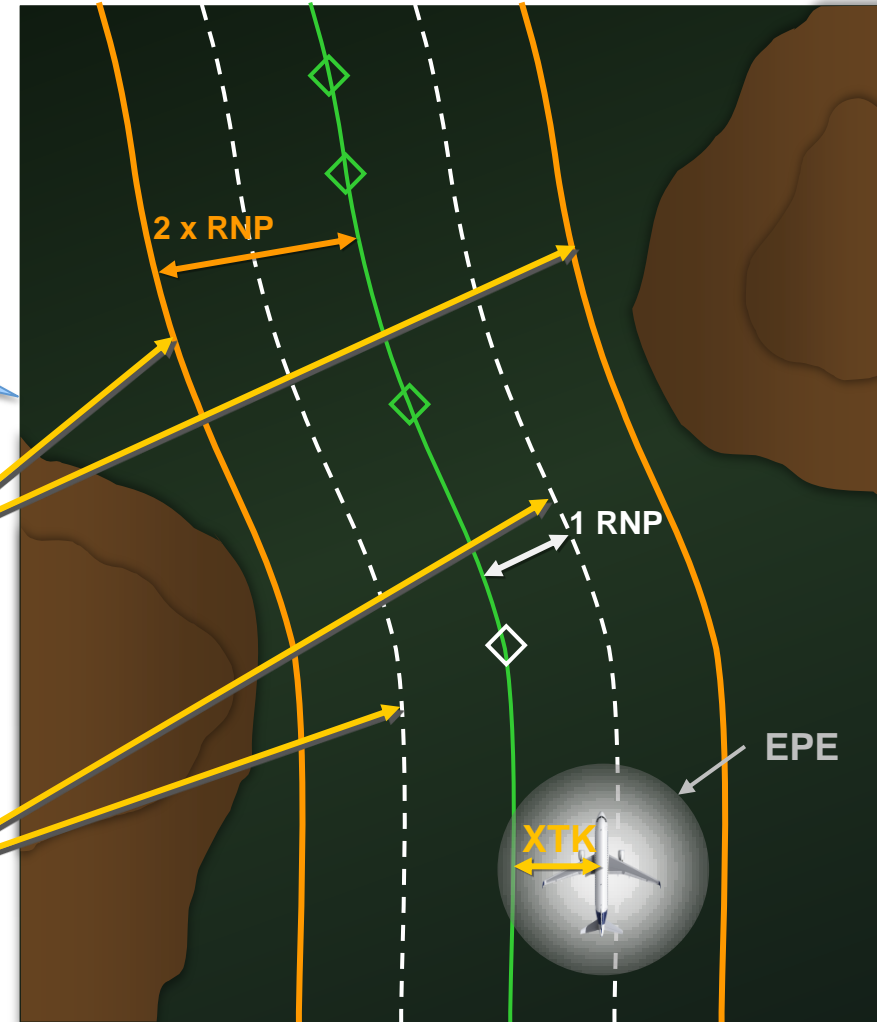

PBN Standard Operating Procedures

PBN – Trajectory Control

Main parameters controlled and monitored by the Flight Crew



It is the responsibility of the Crew to keep LDEV & VDEV inside the operational limits

PBN - Parameters to be monitored

PBN - Parameters to be monitored

Lateral deviation

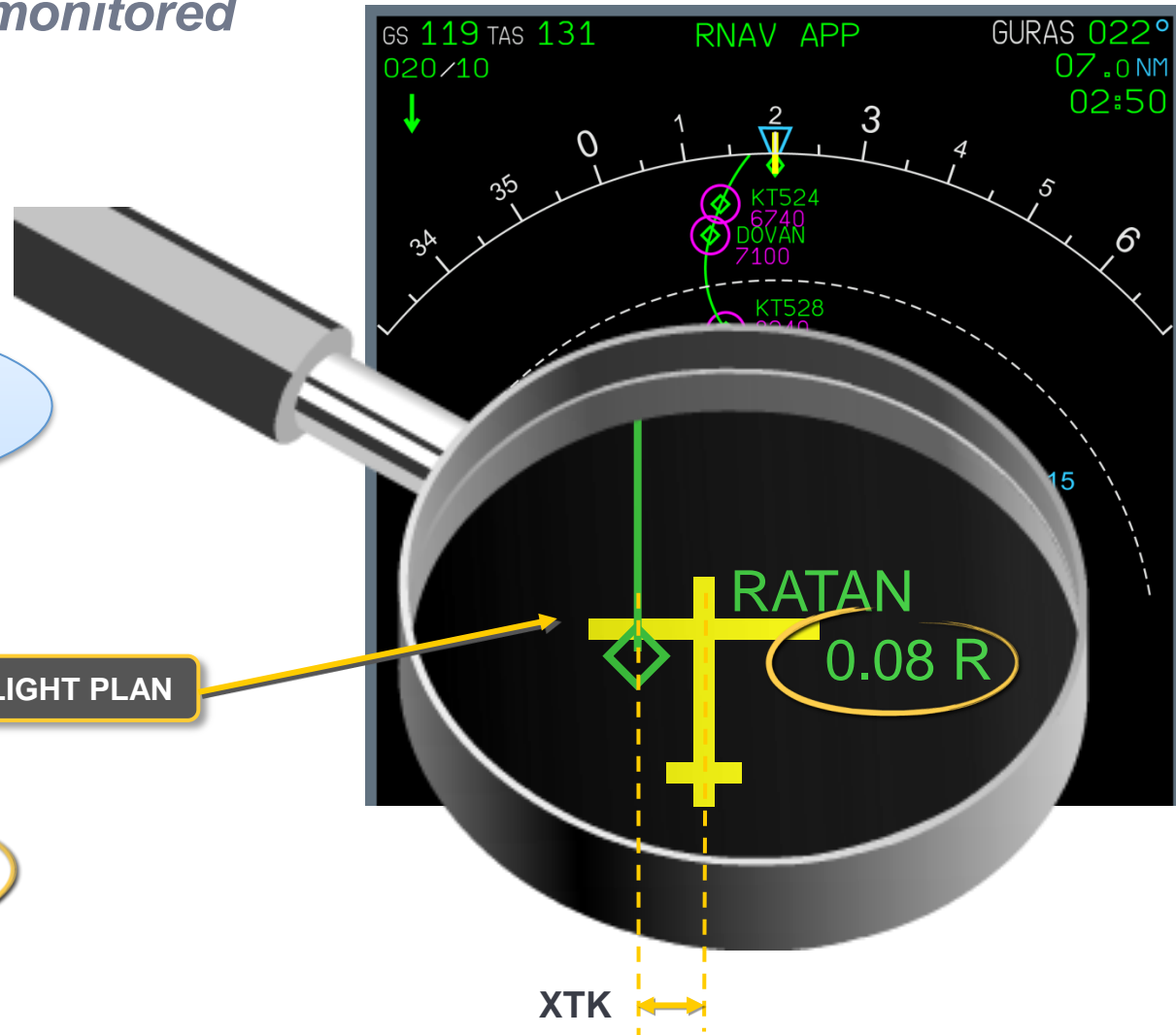
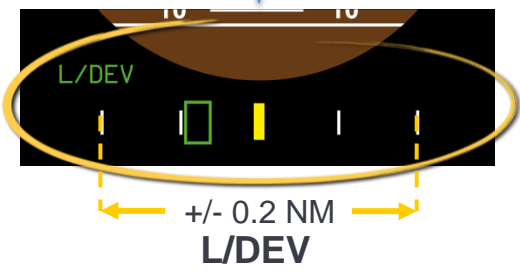
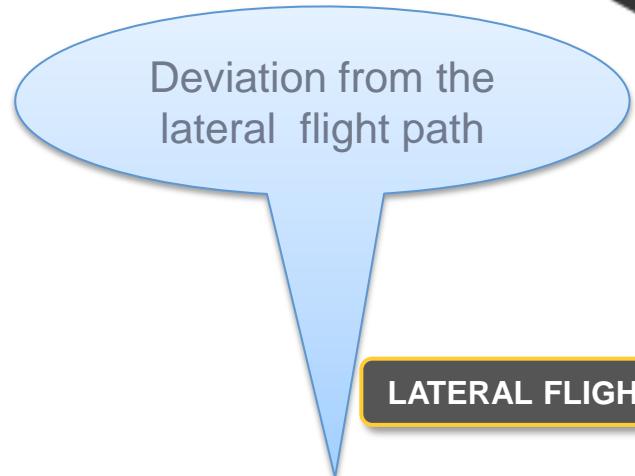

PBN - Parameters to be monitored

PBN - Parameters to be monitored

Vertical deviation

Deviation from the vertical flight path

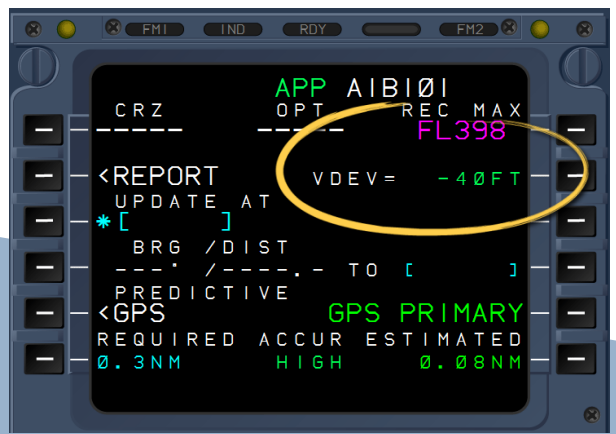

VERTICAL FLIGHT PLAN

INDICATED VERTICAL DEVIATION



V/DEV

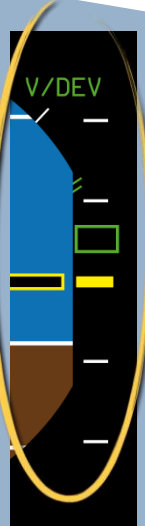

PBN - Parameters to be monitored

PBN - Parameters to be monitored Navigation system

Accuracy level of the navigation system

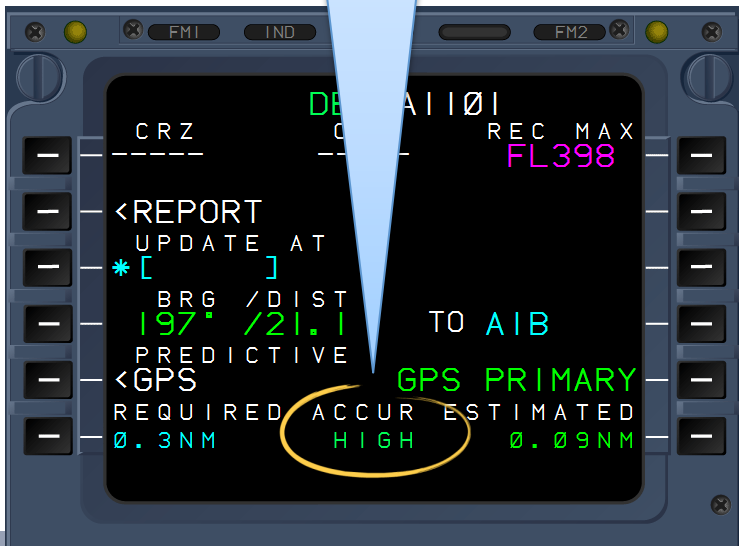

PBN - Parameters to be monitored

PBN - Parameters to be monitored

Navigation system

GPS PRIMARY:

No need for Navigation gross error checking by the crew

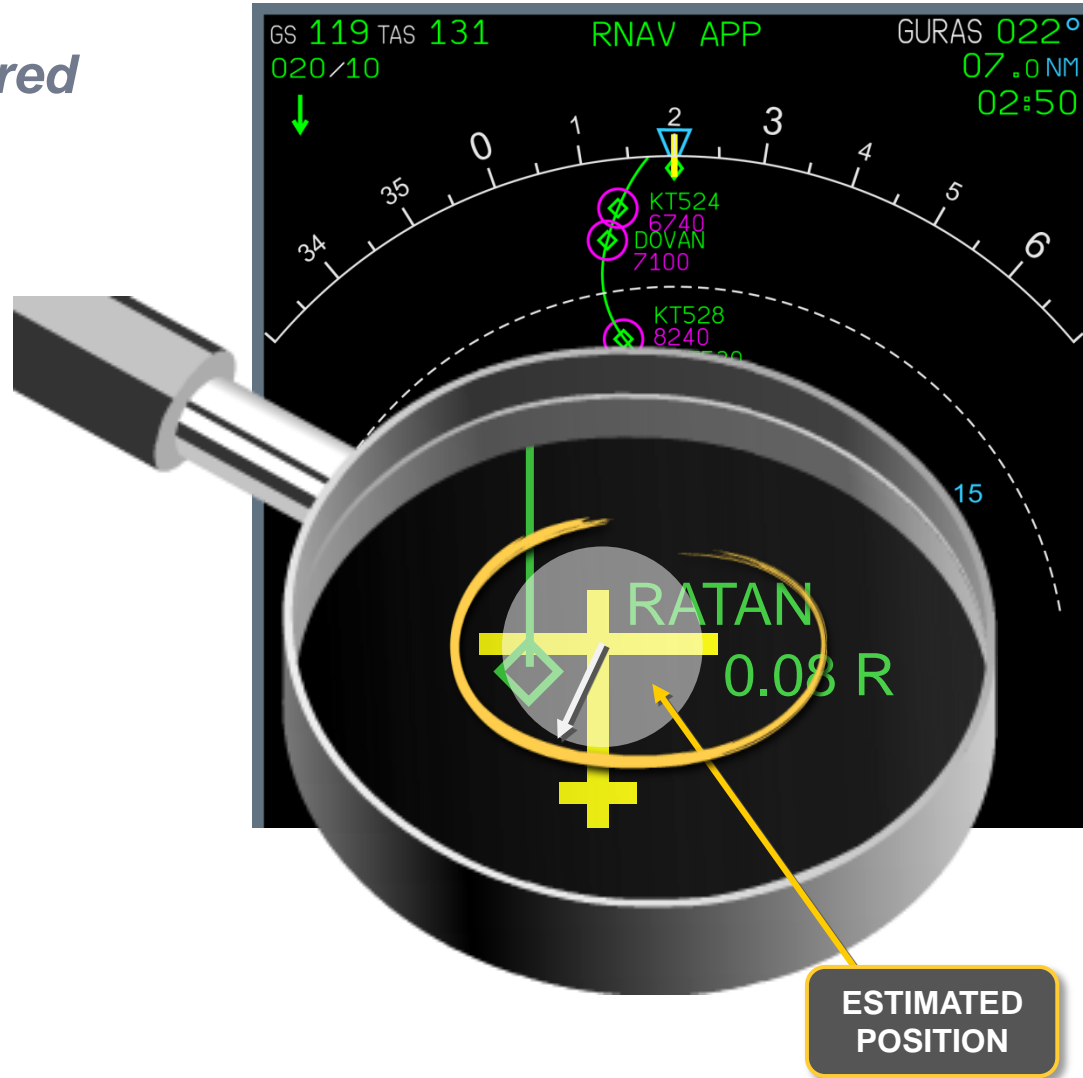
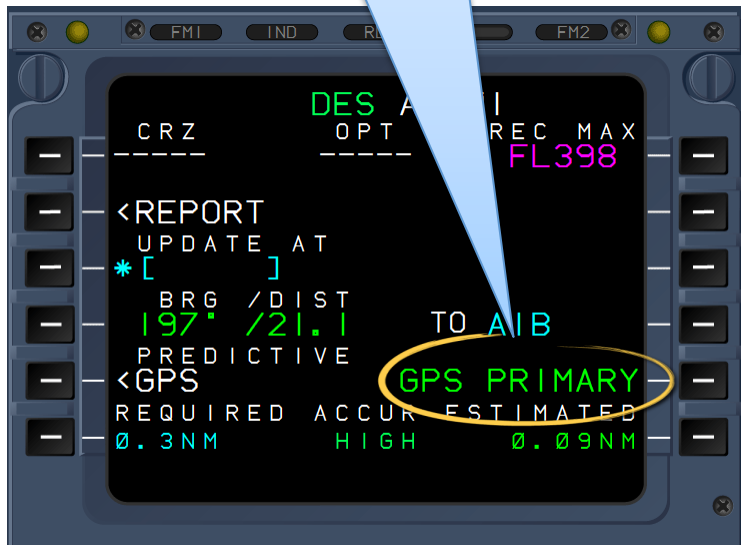

PBN - Parameters to be monitored

PBN - Parameters to be monitored

Altimeter setting

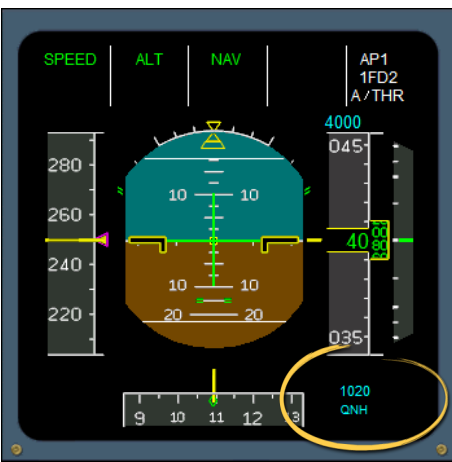

The correct Altimeter Setting is ONLY crew monitored

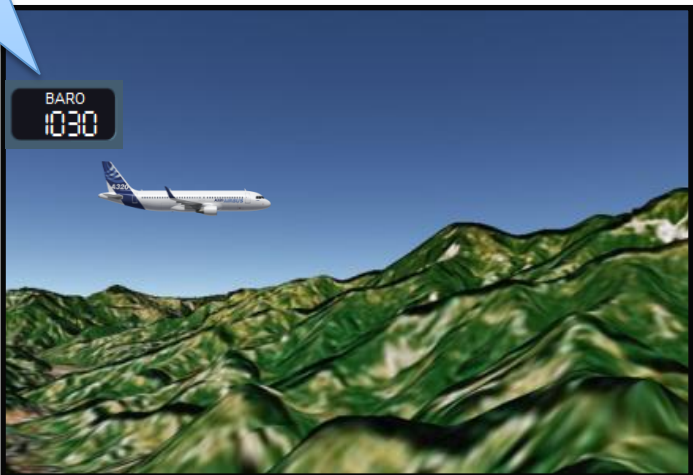
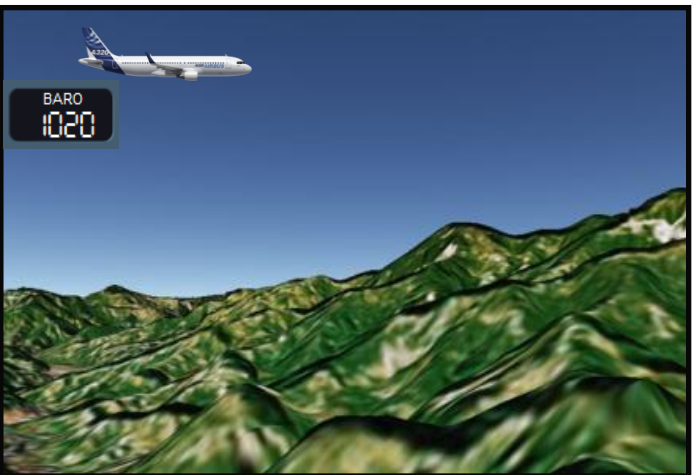
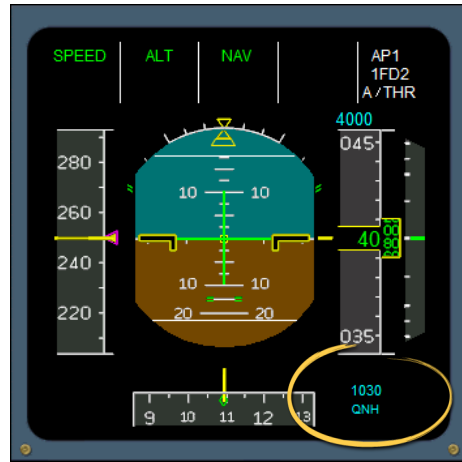

PBN – Standard Operating Procedures

PBN – Standard Operating Procedures

Example: Call-outs for different situations

"CROSSTRACK"

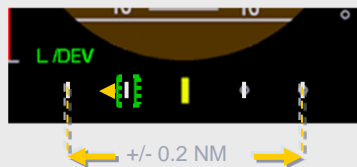

When the lateral deviation reaches 1dot (0.1NM) or ½ RNP.

"V/DEV"

When the vertical deviation reaches half a dot (50ft)



"BANK"



When the bank angle exceeds 30 °.

"SINK RATE"

When the vertical speed exceeds 1200 fpm.



PBN – Standard Operating Procedures

PBN – Standard Operating Procedures

Final approach corridor of an RNP-AR approach, using Baro-VNAV

LATERAL OBSTACLE
CLEARANCE LIMIT

OPERATIONAL
LIMITS

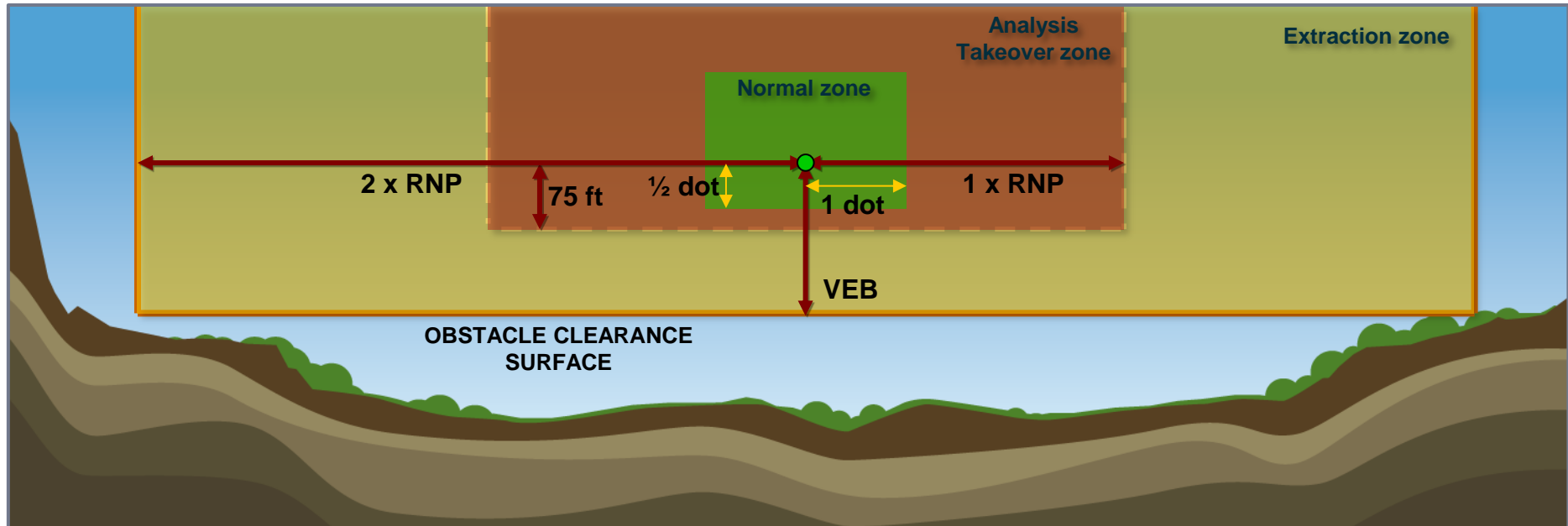

RNP Approaches: RNAV (GNSS)

RNP APCH (with or without Baro-VNAV) characteristics:

- ✓ Straight-in approach on runway axis: 7-10Nm straight final segment
- ✓ Based on 0.3NM (in Final segment)
- ✓ Large obstacle clearance area with buffers
- ✓ ICAO Charting: RNAV (GNSS)
- ✓ With Baro VNAV
 - I. Decision Altitude instead of MDA
 - II. Stabilized approach coded in the FMS down to 50ft above runway threshold
 - I. Final path with constant descent angle

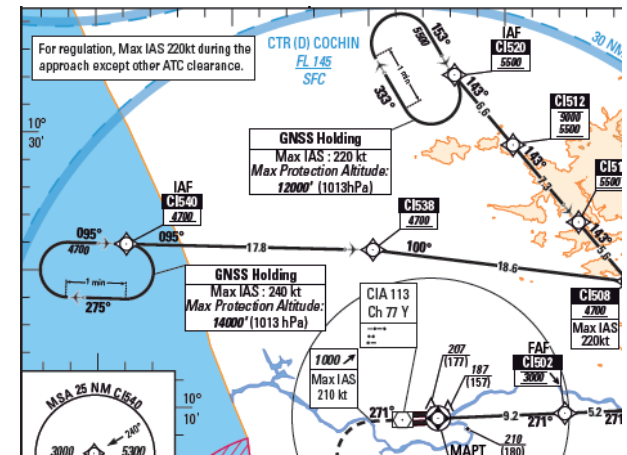

RNP AR Definition

RNP AR stands for **A**uthorization **R**equired (ICAO wording), equivalent to RNP SAAAR (ex-FAA wording)

An RNP AR procedure has one of the following characteristics:

- ✓ Reduced RNP values lower than 0.3 NM in approach (down to 0.1 NM) or lower than 1 NM in missed approach and/or departure;
- ✓ Curved flight path after FAF (RF legs);
- ✓ Reduced obstacle protections, at 2xRNP, without buffers laterally and using a VEB vertically

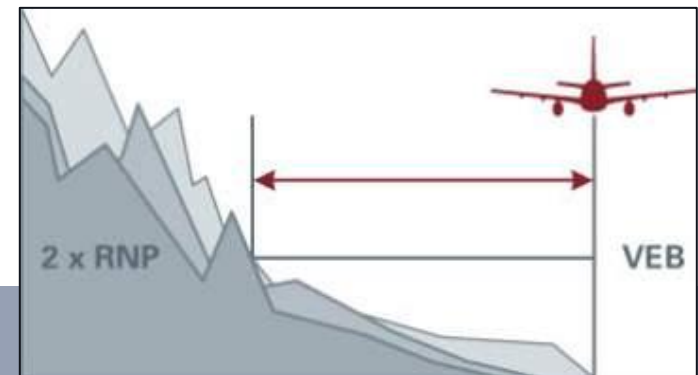
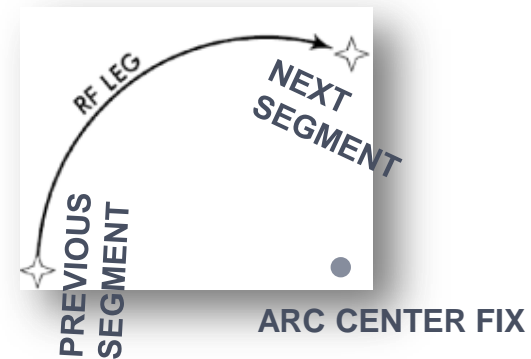

So why and where RNP AR instead of RNP APCH ?

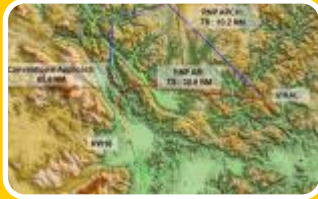

Challenging Terrain

- Enhanced safety
- Increased airport access and operations reliability

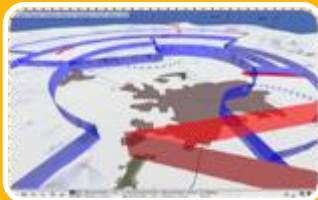

Air Traffic Challenges

- Proximity of airports
- Complex airspace with military / prohibited / restricted areas
- Noise restrictions



Conventional Non-precision approach

- High MD(H)
- Long procedures
- Unreliable ground infrastructure



Business Case / Environmental friendly initiative

- Track Mile savings
- Lower fuel consumption
- Reduced CO2 emissions



RNP and RNP AR Benefits

➤ Airport:

Shorter approaches

Better access

Automated approaches

Lower minima

-  Track of Conventional procedure
-  Track of Visual Approach procedure
-  Track of RNP AR procedure

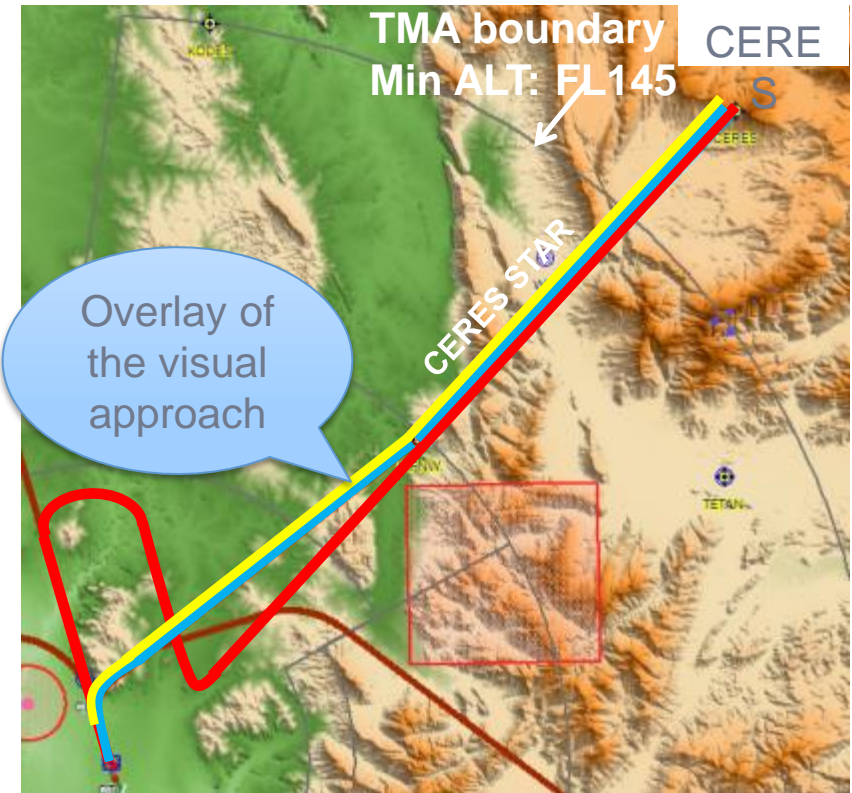

Cape Town RWY 19 RNP AR procedure from CERES

- Repeatable Trajectory
- Fully Managed Approach and Missed Approach
- Less risk of unstabilized approaches

Flexible paths

Cape Town RNP AR:

15NM shorter than conventional

VMC tracks flown in IMC

RWY 16 now fitted with Instrument Flight Procedure



RNP and RNP AR Benefits

➤ Airport:

Shorter approaches

Better access

Automated approaches

Lower minima

Curved Paths - runway alignment in final

- Conventional app in Vagar : **not aligned with runway axis**
- In poor weather conditions, difficult visual maneuver for pilots

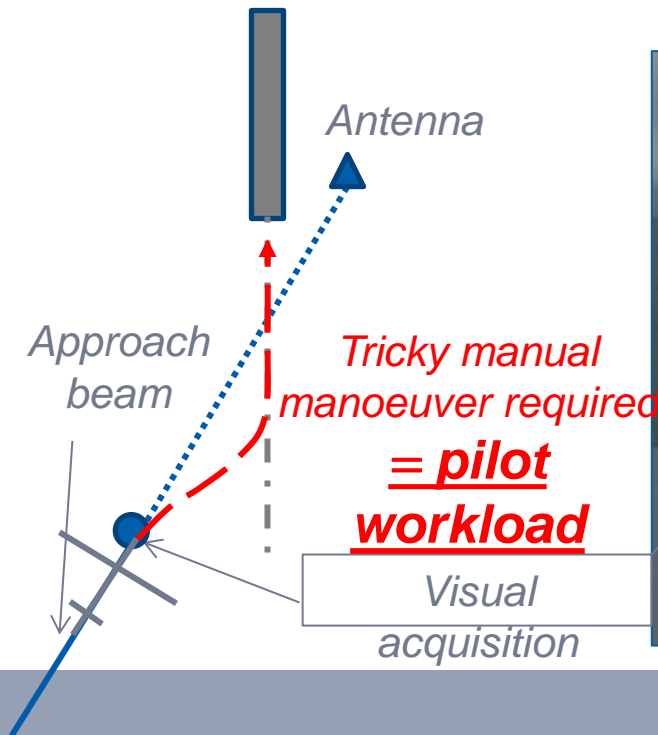

RNP and RNP AR Benefits

Curved Paths - runway alignment in final

- RNP AR approach final is aligned with runway axis.
- In poor weather conditions better position for visual final

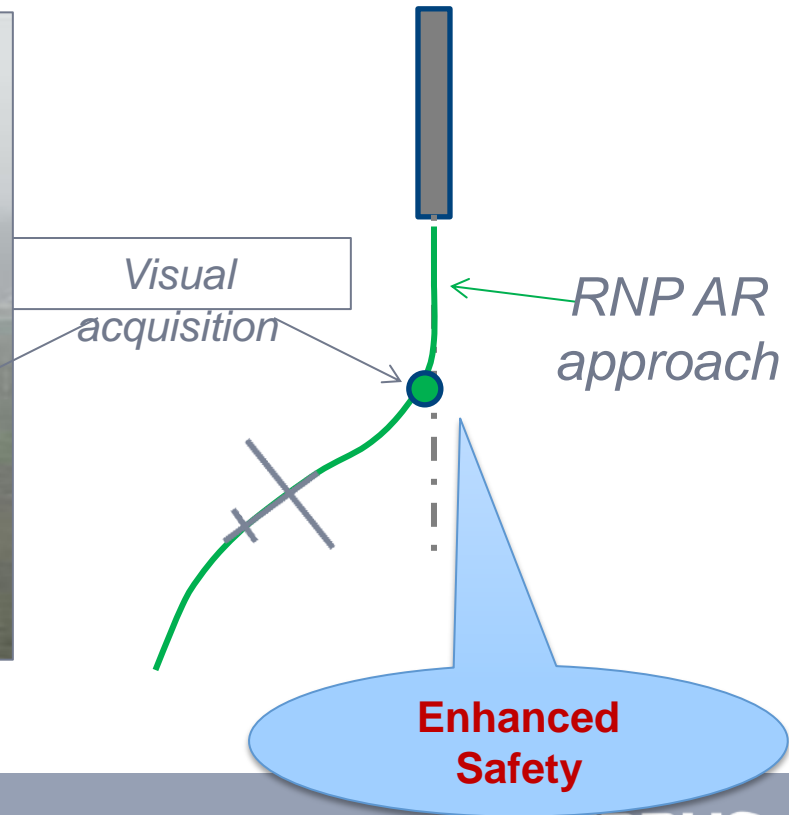

Conclusion

GNSS concept



Summary

- GNSS provide global navigation coverage
- RNP = RNAV + Onboard monitoring and alerting
- Different methods to compute aircraft position
- ABAS already provide huge operational benefits (Baro VNAV down to 250ft DH).
- Most of the > 100 seats aircraft do not have SBAS capabilities
- Appropriate predictions means should be available before starting the operations.

Performance Based Navigation (PBN) Solution

Any Questions?

