

AVIATION CO₂ REDUCTIONS

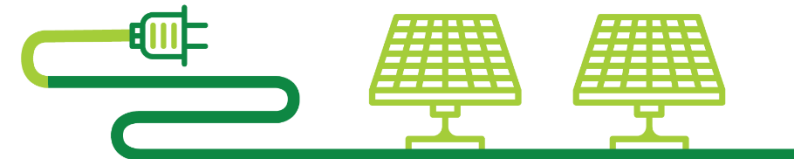

STOCKTAKING SEMINAR

TECHNOLOGY · OPERATIONS · SUSTAINABLE AVIATION FUELS





ICAO

STOCKTAKING 2020

Novel aircraft technological concepts

Artur Mirzoyan

Central Institute of Aviation Motors,
CAEP Member from Russian Federation



Hydrogen: from Tu-155 through HEP/SC to ZEV electrify on HFC/BAT



Sergey Galperin

Director of project “Civil aviation”,
National Research Center “Zhukovsky Institute”,
Russia

Mikhail Gordin

General Director,
CIAM, Russia

Artur Mirzoyan

Central Institute of Aviation Motors,
CAEP Member from Russian Federation

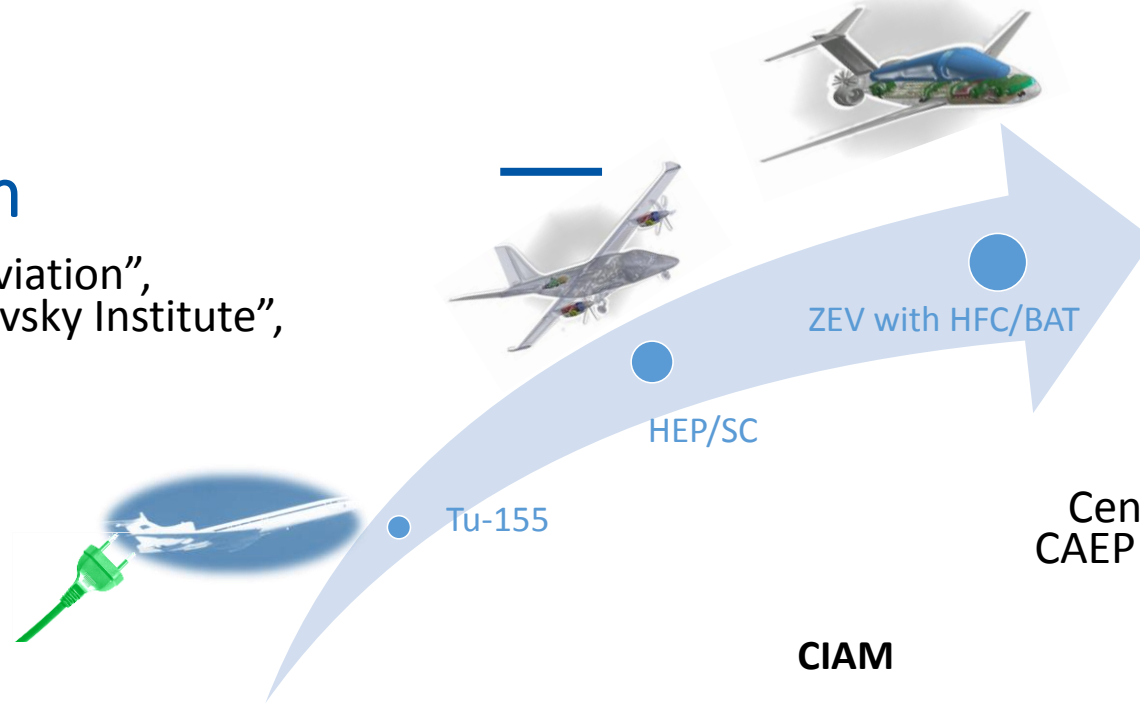

NRC Zhukovsky Institute

- Established in 2014
- 5 leading aviation research institutes (TsAGI, CIAM, GosNIIAS, SibNIA, GKNIPAS)
- **Mandate:** lead and coordinate scientific research, introduce new technologies and oversee new developments in the aviation industry with the aim of bringing innovation to the manufacturing process and using advanced scientific results

CIAM

- Established in 1930
- **Branch:** National Experimental Base
- **Mandate:** world-class scientific center conducting a whole scope of research activities necessary for the development of aircraft engines and gas turbine units based on them

ICAO long term goals and advanced technologies and fuels

Global long-term aspirational goals considered by ICAO

- ❑ Annual 2% improvement of fuel efficiency of international aviation
- ❑ Carbon-neutral growth of net CO₂ emissions of international aviation since 2020



ICAO

In flight CO₂ reduction and change of energy consumption vs. existing technologies

ICAO STOCKTAKING 2020

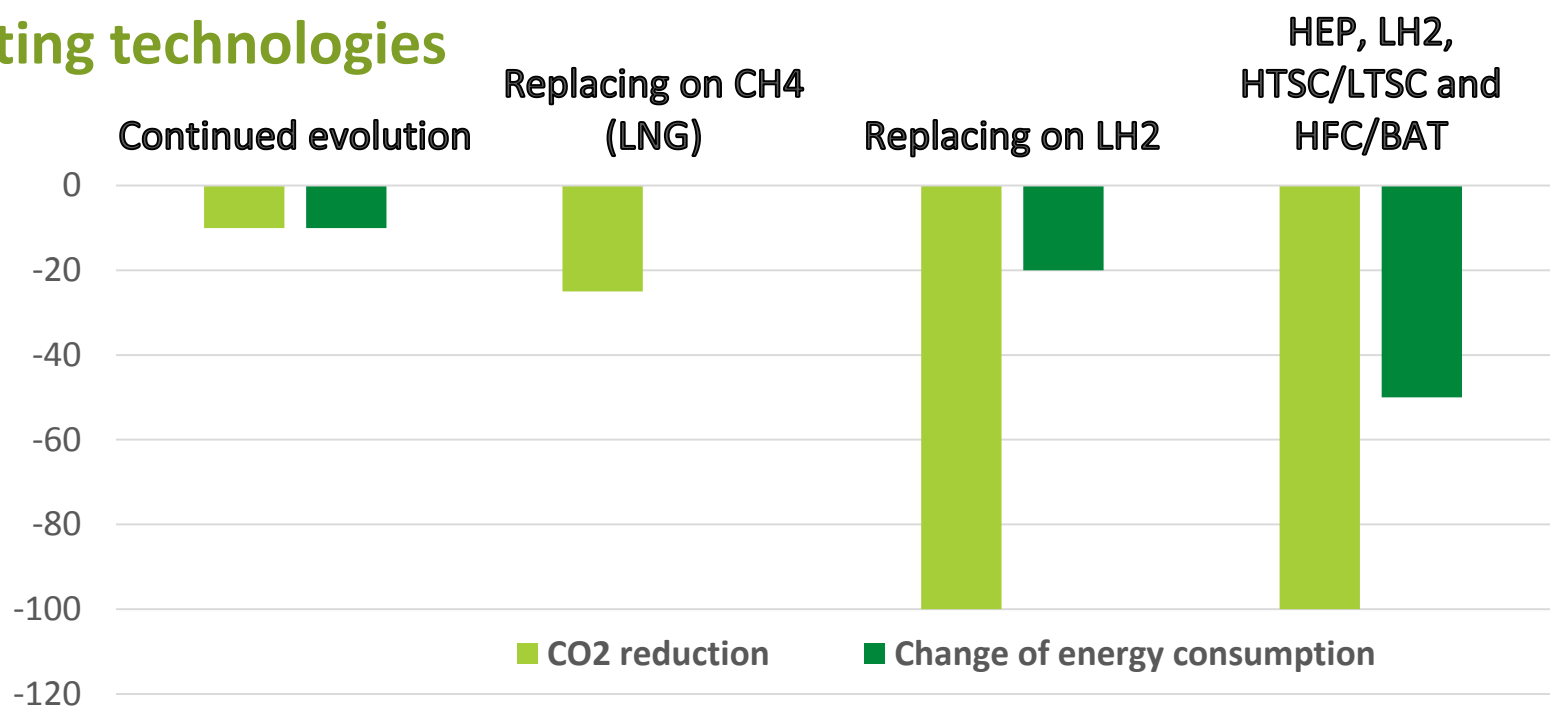

Tu-155 – Russian successful real experience for using hydrogen in aviation



Design features

- one engine is replaced with Kuznetsov NK-88 powered by LH2
- external changes
- cryogenic fuel complex

- First flight - 15 April 1988
- 5 flights with LH2, 100 flights with LNG



Chief designer
Vladimir Andreev
(1925 – 2008)



Crew

Mastered hydrogen technologies

- LH2 cleaning, refueling and draining
- LH2 storage on board and regulation of tank pressure
- LH2 delivering system to the engine, mixing and combustion of hydrogen in the combustor, engine control
- safety of operating with hydrogen

Evolution of the Hybrid Electric Propulsion (HEP)

1. HEP with conventional components

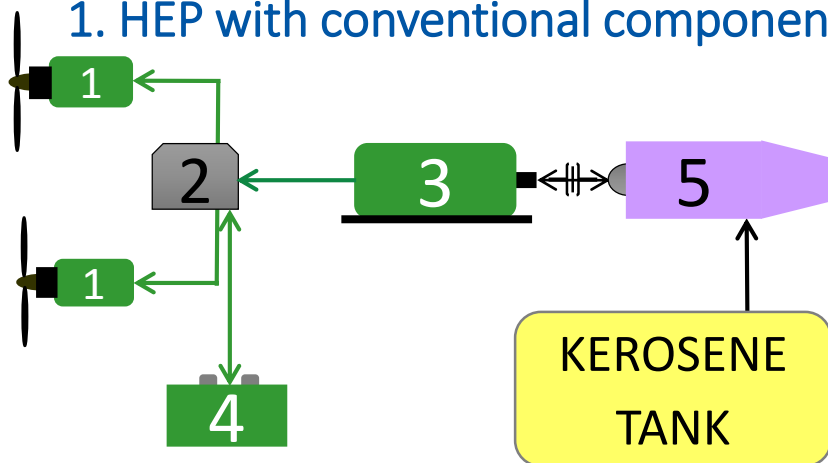

3. HEP with LH2 + LTSC

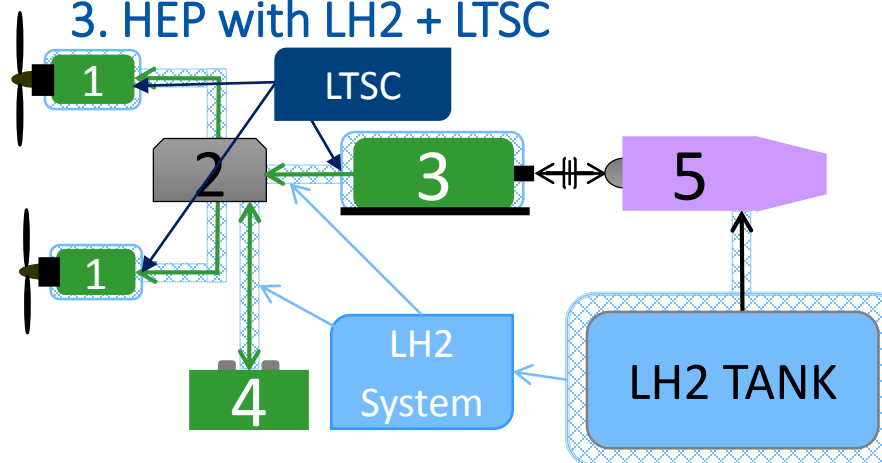

2. HEP with LNG + HTSC

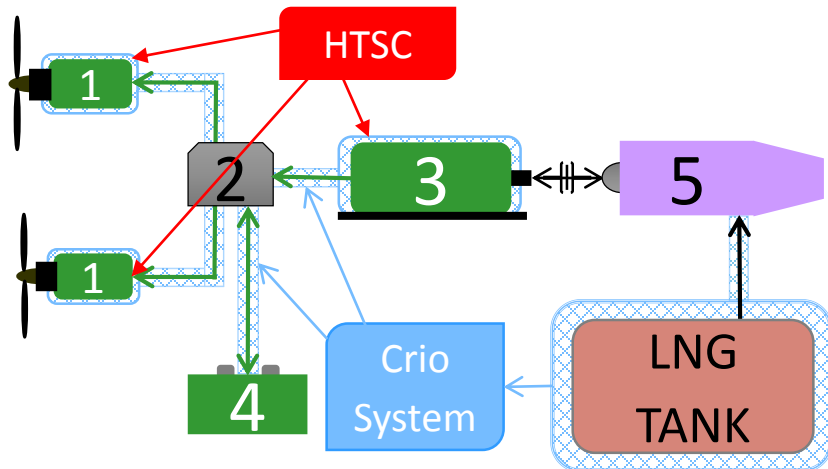

4. HEP with LH2 + LTSC + HFC

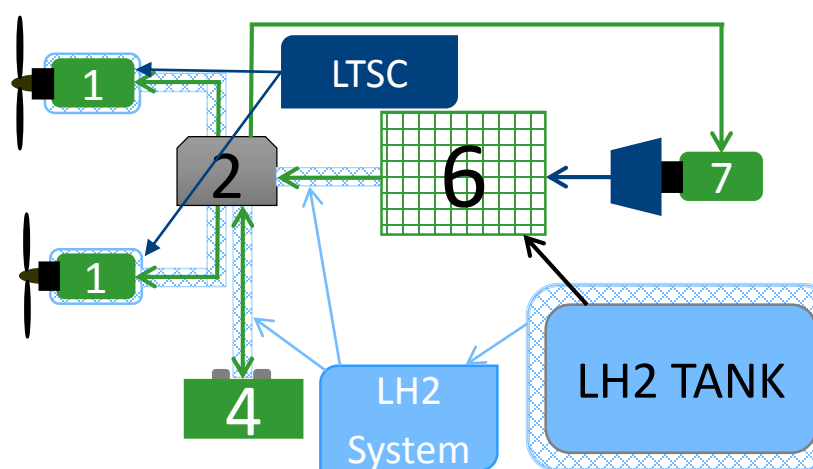

- 1 – Electric motor
- 2 – ECS
- 3 – Starter-Generator
- 4 – Battery
- 5 – GTE part
- 6 – HFC
- 7 – Electrically driven air compressor

Certification aspects of advanced air vehicles

□ First full electric aircraft Pipistrel Velis Electro and its electric propulsion were certified by EASA in June 2020



□ Non-environmental problems:
- safety of electric units, BAT
- BLI safety
- ...

□ New noise requirements (urban transport)

□ Noise&emission certifications based on the life cycle assessment

□ Lack of international standards for the use of LH2 in civil aviation

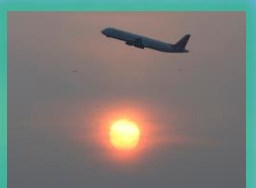

Advanced commercial hydrogen-powered aviation

Technology

Hybrid Electric Propulsion / Distributed Electric Propulsion (HEP/DEP), High and Low Superconductivity (HTSC, LTSC), LNG, LH2, Battery (BAT), Hydrogen Fuel Cells (HFC)



CO₂ emissions reduction for different technology options

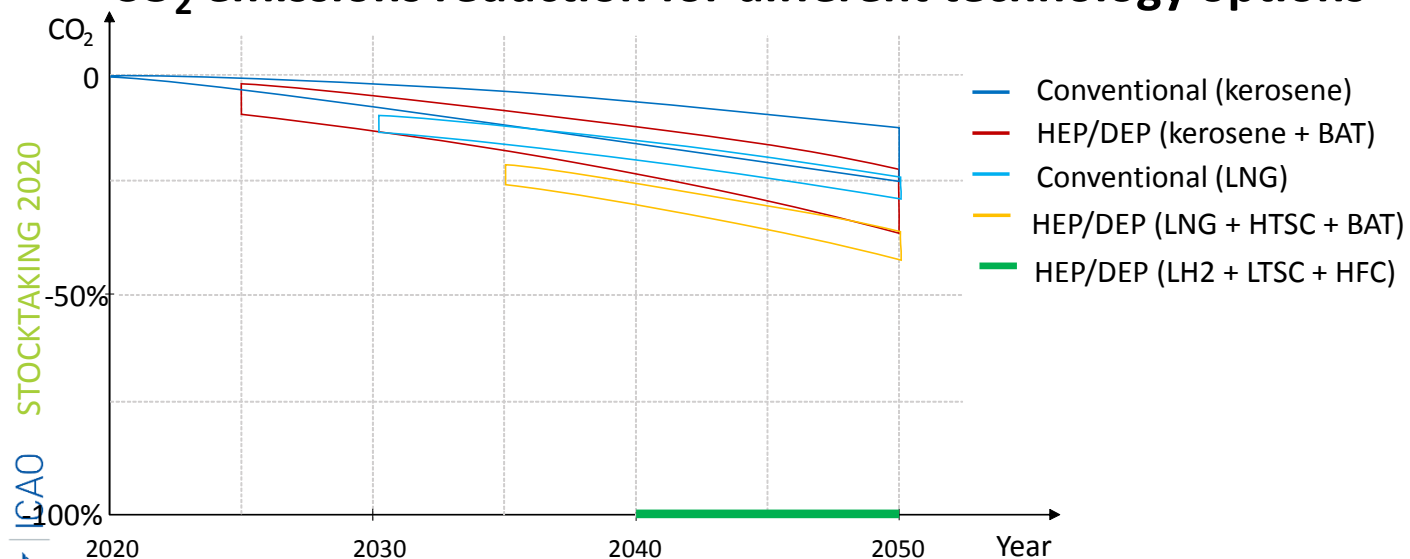

Only HEP using Superconductivity, LH2 and HFC provide CO₂ reduction by 100% !

Copyright © ICAO 2020. All rights reserved

	CO₂ reduction in flight (climate impact)	100% (50-75%)
	Level of finance required*	-20-30% per PAX
	Timeframe	2035-2070
	Main challenges	Capital investment (new design, infrastructure) Green LH2 production Fuel price Lack of Standards

* for short-range aircraft powered by hybrid H2 propulsion (ref. Hydrogen-powered aviation. A fact-based study of hydrogen technology, economics, and climate impact by 2050. May 2020, Clean Sky 2 JU and FCH 2 JU, p.32)

Thank You



ICAO
Headquarters
Montréal

European and
North Atlantic
(EUR/NAT) Office
Paris

Asia and Pacific
(APAC) Sub-office
Beijing

Middle East
(MID) Office
Cairo

Western and
Central African
(WACAF) Office
Dakar

North American
Central American
and Caribbean
(NACC) Office
Mexico City

Asia and Pacific
(APAC) Office
Bangkok

South American
(SAM) Office
Lima

Eastern and
Southern African
(ESAF) Office
Nairobi