



Agenda Item 5

Other Business

**PROPOSAL FOR THE AMENDMENT OF ANNEX 14, VOLUMES I AND II,
RESULTING FROM RECOMMENDATIONS OF THE
SECOND MEETING OF THE AERODROMES PANEL**

(Note presented by the Secretariat)

SUMMARY	
<p>In May 2011, the Air Navigation Commission considered the proposals developed by the second meeting of the Aerodromes Panel (AP/2) and the Secretariat to amend the Standard and Recommended Practices (SARPS) in Annex 14, Volume I – Aerodrome design and Operations and Volume II – Heliports.</p> <p>This Working Paper presents to the meeting the contents and scope of the proposed amendments of Annex 14, including a general review of Volumes I and II.</p>	
<p>References:</p> <ul style="list-style-type: none">• State letter AN 4/1.1.51-11/31 dated 20 April 2011, Ref. Proposal for the amendment of Annex 14, Volume II concerning heliports.• State letter AN 4/1.1.52-11/41 dated 30 May 2011, Ref: Proposal for the amendment of Annex 14, Volume I .	
Strategic Objectives:	A: Aviation safety

1. Introduction

1.1 In order to preserve international air navigation safety and regularity, it is felt that contracting States must meet the specifications of international standards in a uniform manner and comply with the recommended international practices.

1.2 The amendments to the international standards and recommended practices contained in ICAO Annexes originate in the proposals made by the signatory States of the Convention on International Civil Aviation and by international organisations directly related to the international air transportation industry. The purpose of introducing new standards and/or recommendations is to give to certain practical recommendations the category of a standard, or to adapt current SARPs requirements to the changes resulting from the introduction of new generations of aircraft which impact existing aerodrome facilities when the size and/or weight of said aircraft exceed the design parameters used in the planning and development of a given aerodrome. Consideration should also be given to the modification of policies, strategies, and safety management system tactics by the organisations that provide aeronautical services.

2. Development.

2.1 Proposal of amendment to Annex 14, Volume I.

2.1.1 The amendment proposals to Annex 14, Volume I include, amendments in regard to maximum allowable tire pressure category in the reporting of strength of pavements; runway surface friction measurement and reporting; runway end safety areas and arresting systems ; strength of blast pads; visual aids for navigation, including simple touchdown zone lights, enhanced taxiway centre line marking, stop bars, runway guard lights (RGLs) and obstacle lighting; rescue and fire fighting (RFF); including performance level C foam; siting of equipment and installations on operational areas and aerodrome maintenance.

2.1.2 The proposed amendment to Annex 14, Volume I is envisaged for applicability on 15 November 2012.

2.2 Proposal of amendment to Annex 14, Volume II.

2.2.1 The amendment proposal is focus on the second part of the review which consists in two parts for updating the document. There are several proposals covering various topics, such as definitions, heliports information, physical characteristics, obstacle restriction and removal and visual aids.

2.2.2 The proposed amendment to Annex 14, Volume II is envisaged for applicability on 15 November 2012.

3. Discussion

3.1 The aforementioned proposals of amendment envisage major changes to aerodrome safety design and management concepts. Considering that the safety oversight function of a State is part of its safety programme, the objectives of the oversight function are met through administrative controls (inspections, audits, and surveys) periodically conducted by civil aviation authorities. Said proposals must be considered at the time of the aerodrome certification process, which includes the implementation of a safety management system.

4. **Suggested Action**

4.1 The Meeting is invited to take note, review and comment on this working paper, as well as on State Letter AN 471.1.51-11/31 dated 20 April 2011 presented as **Appendix A** to this working paper and State AN 471.1.52-11/41 dated 30 May 2011 presented as **Appendix B** to this working paper.



International
Civil Aviation
Organization

Organisation
de l'aviation civile
internationale

Organización
de Aviación Civil
Internacional

Международная
организация
гражданской
авиации

منظمة الطيران
المدني الدولي

国际民用
航空组织

Tel.: +1 (514) 954-6717

Ref.: AN 4/1.1.51-11/31

20 April 2011

Subject: Proposal for the amendment of Annex 14,
Volume II concerning heliports

Action required: Comments to reach Montréal by
31 July 2011

Sir/Madam,

1. I have the honour to inform you that the Air Navigation Commission, at the eighth meeting of its 186th Session on 15 March 2011, considered the proposals developed by the second meeting of the Aerodromes Panel (AP) to amend the SARPs in Annex 14, Volume II – *Heliports* relating to the design of heliports and authorized their transmission to Contracting States and appropriate international organizations for comments.
2. To facilitate your review of the proposed amendment, the rationale for the proposal has been provided throughout Attachment A in the text boxes immediately following the relevant proposals.
3. The amendment proposals to Annex 14, Volume II address the second part of a two-part comprehensive review and updating of the document. As such there are multiple proposals covering various subjects, including definitions, heliport data, physical characteristics, obstacle restriction and removal and visual aids.
4. In examining the proposed amendment, you should not feel obliged to comment on editorial aspects as such matters will be addressed by the Air Navigation Commission during its final review of the draft amendment.
5. May I request that any comments you may wish to make on the proposed amendment to Annex 14, Volume II be dispatched to reach me not later than 31 July 2011. The Air Navigation Commission has asked me to specifically indicate that comments received after the due date may not be considered by the Commission and the Council. In this connection, should you anticipate a delay in the receipt of your reply, please let me know in advance of the due date.

6. For your information, the proposed amendment to Annex 14, Volume II is envisaged for applicability on 15 November 2012. Any comments you may have thereon would be appreciated.

7. The subsequent work of the Air Navigation Commission and the Council would be greatly facilitated by specific statements on the acceptability or otherwise of the amendment proposal.

8. Please note that, for the review of your comments by the Air Navigation Commission and the Council, replies are normally classified as “agreement with or without comments”, “disagreement with or without comments”, or “no indication of position”. If in your reply the expressions “no objections” or “no comments” are used, they will be taken to mean “agreement without comment” and “no indication of position”, respectively. In order to facilitate proper classification of your response, a form has been included in Attachment B, which may be completed and returned together with your comments, if any, on the proposals in Attachment A.

Accept, Sir/Madam, the assurances of my highest consideration.

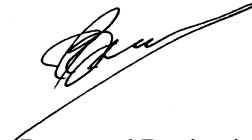
A handwritten signature in black ink, appearing to read 'Raymond Benjamin', with a long, sweeping underline that extends to the right.

Raymond Benjamin
Secretary General

Enclosures:

- A— Proposed amendment to Annex 14, Volume II
- B— Response Form

ATTACHMENT A to State letter AN 4/1.1.51-11/31

**PROPOSED AMENDMENT TO AERODROMES
ANNEX 14, VOLUME II
(HELIPORTS)**

NOTES ON THE PRESENTATION OF THE PROPOSED AMENDMENT

The text of the amendment is arranged to show deleted text with a line through it and new text highlighted with grey shading, as shown below:

1. ~~Text to be deleted is shown with a line through it.~~ text to be deleted
2. **New text to be inserted is highlighted with grey shading.** new text to be inserted
3. ~~Text to be deleted is shown with a line through it~~ followed by the **replacement text which is highlighted with grey shading.** new text to replace existing text

ABBREVIATIONS AND SYMBOLS*(used in Annex 14, Volume II)**Abbreviations*

ASPSL	Arrays of segmented point source lighting
cd	Candela
cm	Centimetre
D	Helicopter greatest overall dimension
FATO	Final approach and take-off area
ft	Foot
GNSS	Global navigation satellite system
HAPI	Helicopter approach path indicator
HFM	Helicopter flight manual
Hz	Hertz
IMC	Instrument meteorological conditions
kg	Kilogram
km/h	Kilometre per hour
kt	Knot
L	Litre
lb	Pounds
LDAH	Landing distance available
L/min	Litre per minute
LOA	Limited obstacle area
LOS	Limited obstacle sector
LP	Luminescent panel
m	Metre
MAPt	Missed approach point
MTOM	Maximum take-off mass
OFS	Obstacle free sector
PinS	Point-in-space
RD	Diameter of the largest rotor
R/T	Radio Telephony or radio communications
RTODAH	Rejected take-off distance available
s	Second
SBAS	Satellite-based augmentation system
t	Metric tonne (1000 kg)
TLOF	Touchdown and lift-off area
TODAH	Take-off distance available
UCW	Undercarriage width
VMC	Visual meteorological conditions
VSS	Visual segment surface

Symbols

°	Degree
=	Equals
%	Percentage
±	Plus or minus

INTERNATIONAL STANDARDS AND RECOMMENDED PRACTICES

CHAPTER 1. GENERAL

Introductory Note.— Annex 14, Volume II, contains Standards and Recommended Practices (specifications) that prescribe the physical characteristics and obstacle limitation surfaces to be provided for at heliports, and certain facilities and technical services normally provided at a heliport. It is not intended that these specifications limit or regulate the operation of an aircraft.

When designing a heliport, the critical design helicopter, having the largest set of dimensions and the greatest maximum take-off mass (MTOM) the heliport is intended to serve, would need to be considered.

It is to be noted that provisions for helicopter flight operations are contained in Annex 6, Part III.

1.1 Definitions

When the following terms are used in this volume, they have the meanings given below. Annex 14, Volume I, contains definitions for those terms which are used in both volumes.

Accuracy. A degree of conformance between the estimated or measured value and the true value.

Note.— For measured positional data, the accuracy is normally expressed in terms of a distance from a stated position within which there is a defined confidence of the true position falling.

~~**Air transit route.** A defined route for the air transiting of helicopters.~~

Calendar. Discrete temporal reference system that provides the basis for defining temporal position to a resolution of one day (ISO 19108^{*}).

Cyclic redundancy check (CRC). A mathematical algorithm applied to the digital expression of data that provides a level of assurance against loss or alteration of data.

D. The largest overall dimension of the helicopter when rotor(s) are turning measured from the most forward position of the main rotor tip path plane to the most rearward position of the tail rotor tip path plane or helicopter structure.

Note.— “D” is sometimes referred to in the text using the terminology “D-value”.

Data quality. A degree or level of confidence that the data provided meet the requirements of the data user in terms of accuracy, resolution and integrity.

^{*} ISO Standard 19108, *Geographic information — Temporal schema*

Datum. Any quantity or set of quantities that may serve as a reference or basis for the calculation of other quantities (ISO 19104**).

Declared distances — heliports.

- a) *Take-off distance available (TODAH).* The length of the FATO plus the length of helicopter clearway (if provided) declared available and suitable for helicopters to complete the take-off.
- b) *Rejected take-off distance available (RTODAH).* The length of the FATO declared available and suitable for helicopters operated in performance class 1 to complete a rejected take-off.
- c) *Landing distance available (LDAH).* The length of the FATO plus any additional area declared available and suitable for helicopters to complete the landing manoeuvre from a defined height.

Dynamic load-bearing surface. A surface capable of supporting the loads generated by a helicopter conducting an emergency touchdown on it.

Elevated heliport. A heliport located on a raised structure ~~on land~~.

Ellipsoid height (Geodetic height). The height related to the reference ellipsoid, measured along the ellipsoidal outer normal through the point in question.

FATO/TLOF. Specific case where a FATO and a TLOF occupy the same space on an elevated heliport, a helideck or a shipboard heliport.

Final approach and take-off area (FATO). A defined area over which the final phase of the approach manoeuvre to hover or landing is completed and from which the take-off manoeuvre is commenced. Where the FATO is to be used by helicopters operated in performance class 1, the defined area includes the rejected take-off area available.

Geodetic datum. A minimum set of parameters required to define location and orientation of the local reference system with respect to the global reference system/frame.

Geoid. The equipotential surface in the gravity field of the Earth which coincides with the undisturbed mean sea level (MSL) extended continuously through the continents.

Note.— The geoid is irregular in shape because of local gravitational disturbances (wind tides, salinity, current, etc.) and the direction of gravity is perpendicular to the geoid at every point.

Geoid undulation. The distance of the geoid above (positive) or below (negative) the mathematical reference ellipsoid.

Note.— In respect to the World Geodetic System — 1984 (WGS-84) defined ellipsoid, the difference between the WGS-84 ellipsoidal height and orthometric height represents WGS-84 geoid undulation.

Gregorian calendar. Calendar in general use; first introduced in 1582 to define a year that more closely approximates the tropical year than the Julian calendar (ISO 19108***).

** ISO Standard 19104, *Geographic information — Terminology*

Note.— In the Gregorian calendar, common years have 365 days and leap years 366 days divided into twelve sequential months.

Helicopter air taxiway. A defined path on the surface established for the air taxiing of helicopters.

Helicopter clearway. A defined area on the ground or water, selected and/or prepared as a suitable area over which a helicopter operated in performance class 1 may accelerate and achieve a specific height.

Helicopter ground taxiway. A ground taxiway intended for the ground movement of wheeled undercarriage helicopters.

Helicopter stand. An aircraft stand which provides for parking a helicopter and where ground taxi operations are completed or where the helicopter touches down and lifts off for air taxi operations.

Helicopter taxi-route. A defined path established for the movement of helicopters from one part of a heliport to another. A taxi-route includes a helicopter air or ground taxiway which is centred on the taxi-route.

Helideck. A heliport located on an fixed or floating offshore structure—facility such as an exploration and/or production platform—unit used for the exploitation of oil or gas.

Heliport. An aerodrome or a defined area on a structure intended to be used wholly or in part for the arrival, departure and surface movement of helicopters.

Heliport elevation. The elevation of the highest point of the FATO expressed as the distance above mean sea level.

Integrity (aeronautical data). A degree of assurance that an aeronautical data and its value has not been lost nor altered since the data origination or authorized amendment.

Obstacle. All fixed (whether temporary or permanent) and mobile objects, or parts thereof, that:

- a) are located on an area intended for the surface movement of aircraft; or
- b) extend above a defined surface intended to protect aircraft in flight; or
- c) stand outside those defined surfaces and that have been assessed as being a hazard to air navigation.

Orthometric height. Height of a point related to the geoid, generally presented as an MSL elevation.

Point-in-space approach (PinS). The Point-in-space approach is based on GNSS or SBAS and is an approach procedure designed for helicopters only. It is aligned with a reference point located to permit subsequent flight manoeuvring or approach and landing using visual manoeuvring in adequate visual conditions to see and avoid obstacles.

Point-in-space (PinS) visual segment. This is the segment of a helicopter PinS approach procedure from the MAPt to the landing location for a PinS “proceed visually” procedure. The visual segment connects the Point-in-space (PinS) to the landing location.

Protection area. An area within a taxi-route and around a helicopter stand which provides separation from objects, the FATO, other taxi-routes and helicopter stands, for safe manoeuvring of helicopters.

Rejected take-off area. A defined area on a heliport suitable for helicopters operating in performance class 1 to complete a rejected take-off.

Runway-type FATO. A FATO having characteristics similar in shape to a runway.

Safety area. A defined area on a heliport surrounding the FATO which is free of obstacles, other than those required for air navigation purposes, and intended to reduce the risk of damage to helicopters accidentally diverging from the FATO.

Shipboard heliport. A heliport located on a ship that may be purpose or non-purpose-built. A purpose-built shipboard heliport is one designed specifically for helicopter operations. A non-purpose-built shipboard heliport is one that utilizes an area of the ship that is capable of supporting a helicopter but not designed specifically for that task.

Static load-bearing surface. A surface capable of supporting the mass of a helicopter situated upon it.

Station declination. An alignment variation between the zero degree radial of a VOR and true north, determined at the time the VOR station is calibrated.

Surface-level heliport. A heliport located on the ground or on a structure on the surface of the water.

~~**Taxi-route.** A defined path established for the movement of helicopters from one part of a heliport to another. A taxi route includes a helicopter air or ground taxiway which is centred on the taxi route.~~

Touchdown and lift-off area (TLOF). An area on which a helicopter may touch down or lift off.

Winching area. An area provided for the transfer by helicopter of personnel or stores to or from a ship.

1.2 Applicability

Note.— The dimensions discussed in this Annex are based on consideration of single-main-rotor helicopters. For tandem-rotor helicopters the heliport design will be based on a case-by-case review of the specific models using the basic requirement for a safety area and protection areas specified in this Annex. The specifications of the main chapters of this Annex are applicable for visual heliports that may or may not incorporate the use of a Point-in-space approach. Additional specifications for instrument heliports with non-precision and/or precision approaches and instrument departures are detailed in Appendix 2. The specifications of this Annex are not applicable for water heliports.

1.2.1 The interpretation of some of the specifications in the Annex expressly requires the exercising of discretion, the taking of a decision or the performance of a function by the appropriate authority. In other specifications, the expression appropriate authority does not actually appear although its inclusion is implied. In both cases, the responsibility for whatever determination or action is necessary shall rest with the State having jurisdiction over the heliport.

1.2.2 The specifications in Annex 14, Volume II, shall apply to all heliports intended to be used by helicopters in international civil aviation. They shall apply equally to areas for the exclusive use of helicopters at an aerodrome primarily meant for the use of aeroplanes. Where relevant, the provisions of Annex 14, Volume I, shall apply to the helicopter operations being conducted at such an aerodrome.

1.2.3 Unless otherwise specified, the specification for a colour referred to within this volume shall be that contained in Appendix 1 to Annex 14, Volume I.

CHAPTER 2. HELIPORT DATA

2.3 Heliport elevation

2.3.1 The heliport elevation and geoid undulation at the heliport elevation position shall be measured and reported to the aeronautical information services authority to the accuracy of one-half metre or foot.

2.3.2 ~~For a heliport used by international civil aviation, t~~ The elevation of the TLOF and/or the elevation and geoid undulation of each threshold of the FATO (where appropriate) shall be measured and reported to the aeronautical information services authority to the accuracy of one half metre or foot;

- ~~a) one half metre or foot for non-precision approaches; and~~
- ~~b) one quarter metre or foot for precision approaches.~~

Note.— Geoid undulation must be measured in accordance with the appropriate system of coordinates.

2.4 Heliport dimensions and related information

2.4.1 The following data shall be measured or described, as appropriate, for each facility provided on a heliport:

- a) heliport type — surface-level, elevated, shipboard or helideck;
- b) TLOF — dimensions to the nearest metre or foot, slope, surface type, bearing strength in tonnes (1 000 kg);

- c) ~~FATO final approach and take-off area~~ — type of FATO, true bearing to one-hundredth of a degree, designation number (where appropriate), length, ~~and~~ width to the nearest metre or foot, slope, surface type;
- d) safety area — length, width and surface type;
- e) helicopter ground taxiway, ~~and~~ air taxiway ~~and air transit route~~ — designation, width, surface type;
- f) apron — surface type, helicopter stands;
- g) clearway — length, ground profile;
- h) visual aids for approach procedures, marking and lighting of FATO, TLOF, taxiways and ~~helicopter stands~~ ~~aprons~~; and
- i) ~~distances to the nearest metre or foot of localizer and glide path elements comprising an instrument landing system (ILS) or azimuth and elevation antenna of a microwave landing system (MLS) in relation to the associated TLOF or FATO extremities.~~

2.4.2 The geographical coordinates of the geometric centre of the TLOF and/or of each threshold of the FATO (where appropriate) shall be measured and reported to the aeronautical information services authority in degrees, minutes, seconds and hundredths of seconds.

2.4.3 The geographical coordinates of appropriate centre line points of helicopter ground taxiways, and air taxiways ~~and air transit routes~~ shall be measured and reported to the aeronautical information services authority in degrees, minutes, seconds and hundredths of seconds.

2.4.4 The geographical coordinates of each helicopter stand shall be measured and reported to the aeronautical information services authority in degrees, minutes, seconds and hundredths of seconds.

2.4.5 The geographical coordinates of obstacles in Area 2 (the part within the heliport boundary) and in Area 3 shall be measured and reported to the aeronautical information services authority in degrees, minutes, seconds and tenths of seconds. In addition, the top elevation, type, marking and lighting (if any) of obstacles shall be reported to the aeronautical information services authority.

Note 1.— See Annex 15, Appendix 8, for graphical illustrations of obstacle data collection surfaces and criteria used to identify obstacles in Areas 2 and 3.

Note 2.— Appendix 1 to this Annex provides requirements for obstacle data determination in Areas 2 and 3.

Note 3.— Implementation of Annex 15, provision 10.6.1.2, concerning the availability, as of 18 November 2010, of obstacle data according to Area 2 and Area 3 specifications would be facilitated by appropriate advance planning for the collection and processing of such data.

Rationale

Instrument heliport requirements have been moved to Appendix 2, thus only leaving non-instrument criteria which has been standardized at one half metre or foot for measurement accuracy.

CHAPTER 3. PHYSICAL CHARACTERISTICS

3.1 Surface-level heliports

Note 1.— The following specifications are for land based heliports only. Where a water heliport is being considered, the appropriate authority may establish suitable criteria.

Note 2.— The dimensions of the taxi routes and helicopter stands include a protection area.

Note 1.— The provisions given in this section are based on the design assumption that no more than one helicopter will be in the FATO at the same time.

Note 2.— The design provisions given in this section assume when conducting operations to a FATO in proximity to another FATO, these operations will not be simultaneous. If simultaneous helicopter operations are required, appropriate separation distances between FATOs need to be determined, giving due regard to such issues as rotor downwash and airspace, and ensuring the flight paths for each FATO, defined in Chapter 4, do not overlap.

Note 3.— The specifications for ground taxi-routes and air taxi-routes are intended for the safety of simultaneous operations during the manoeuvring of helicopters. However, the wind velocity induced by the rotor downwash might have to be considered.

Final approach and take-off areas

3.1.1 A surface-level heliport shall be provided with at least one final approach and take-off area (FATO).

Note.— A FATO may be located on or near a runway strip or taxiway strip.

3.1.2 A FATO shall be obstacle free.

3.1.3 The dimensions of a FATO shall be:

- a) where intended to be used by helicopters operated in performance class 1, as prescribed in the helicopter flight manual (HFM) except that, in the absence of width specifications, the width shall be not less than the greatest overall dimension (D) of the largest helicopter the FATO is intended to serve;

- b) where intended to be used by helicopters operated in performance class 2 or 3, of sufficient size and shape to contain an area within which can be drawn a circle of diameter not less than:
- 1) 1 D of the largest helicopter when the maximum take-off mass (MTOM) of helicopters the FATO is intended to serve is more than 3 175 kg;
 - 2) 0.83 D of the largest helicopter when the MTOM of helicopters the FATO is intended to serve is 3 175 kg or less.

Note.— Where the term FATO is not used in the HFM, the minimum landing/take-off area specified in the HFM for the appropriate flight profile is used.

3.1.4 Recommendation.— Where intended to be used by helicopters operated in performance class 2 or 3 with MTOM of 3 175 kg or less, the FATO should be of sufficient size and shape to contain an area within which can be drawn a circle of diameter not less than 1 D.

Note.— Local conditions, such as elevation and temperature, may need to be considered when determining the size of a FATO. Guidance is given in the Heliport Manual (Doc 9261).

3.1.5 The FATO shall provide rapid drainage but the mean slope in any direction on the FATO shall not exceed 3 per cent. No portion of a FATO shall have a local slope exceeding:

- a) 5 per cent where the heliport is intended to be used by helicopters operated in performance class 1; and
- b) 7 per cent where the heliport is intended to be used by helicopters operated in performance class 2 or 3.

3.1.6 The surface of the FATO shall:

- a) be resistant to the effects of rotor downwash;
- b) be free of irregularities that would adversely affect the take-off or landing of helicopters; and
- c) have bearing strength sufficient to accommodate a rejected take-off by helicopters operated in performance class 1.

3.1.7 The surface of a FATO surrounding a touchdown and lift-off area (TLOF) intended for use by helicopters operated in performance classes 2 and 3 shall be static load-bearing.

3.1.8 Recommendation.— The FATO should provide ground effect.

3.1.9 Recommendation.— The FATO should be located so as to minimize the influence of the surrounding environment, including turbulence, which could have an adverse impact on helicopter operations.

Note.— Guidance on determining the influence of turbulence is given in the Heliport Manual (Doc 9261). If turbulence mitigating design measures are warranted but not practical, operational limitations may need to be considered under certain wind conditions.

Helicopter clearways

Note.— A helicopter clearway would need to be considered when the heliport is intended to be used by helicopters operating in performance class 1. See Heliport Manual (Doc 9261).

3.1.9~~10~~ When a helicopter clearway is provided, it shall be located beyond the end of the rejected take-off area available FATO.

3.1.4~~11~~ **Recommendation.**— The width of a helicopter clearway should not be less than that of the associated safety area (see Figure 3-1).

3.1.4~~12~~ **Recommendation.**— The ground in a helicopter clearway should not project above a plane having an upward slope of 3 per cent, the lower limit of this plane being a horizontal line which is located on the periphery of the FATO.

3.1.4~~13~~ **Recommendation.**— An object situated ~~on~~ in a helicopter clearway, which may endanger helicopters in the air, should be regarded as an obstacle and should be removed.

Touchdown and lift-off areas

3.1.4~~3~~14 At least one TLOF shall be provided at a heliport.

3.1.15 One TLOF shall be located within the FATO or one or more TLOFs shall be collocated with helicopter stands. For runway-type FATOs, additional TLOFs located in the FATO are acceptable. For further guidance see Heliport Manual (Doc 9261).

Note 1.— The TLOF may or may not be located within the FATO.

Note 2.— Additional TLOFs may be collocated with helicopter stands.

3.1.4~~4~~16 The TLOF shall be of sufficient size to contain a circle of diameter of at least 0.83 D of the largest helicopter the area is intended to serve.

Note.— A TLOF may be any shape.

3.1.4~~5~~17 Slopes on a TLOF shall be sufficient to prevent accumulation of water on the surface of the area, but shall not exceed 2 per cent in any direction.

3.1.4~~6~~18 Where the TLOF is within the FATO, the TLOF shall be dynamic load-bearing.

3.1.4~~7~~19 Where a TLOF is collocated with a helicopter stand, the TLOF shall be static load-bearing and be capable of withstanding the traffic of helicopters that the area is intended to serve.

3.1.4~~8~~20 Where ~~the~~ a TLOF is located within ~~the~~ a FATO which can contain a circle of diameter more than 1 D, the centre of the TLOF shall be located not less than 0.5 D from the edge of the FATO.

Safety areas

3.1.19~~21~~ A FATO shall be surrounded by a safety area which need not be solid.

3.1.20~~22~~ A safety area surrounding a FATO ~~intended to be used by helicopters operated in performance class 1 in visual meteorological conditions (VMC)~~ shall extend outwards from the periphery of the FATO for a distance of at least 3 m or 0.25 D, whichever is greater, of the largest helicopter the FATO is intended to serve and:

- a) each external side of the safety area shall be at least 2 D where the FATO is quadrilateral; or
- b) the outer diameter of the safety area shall be at least 2 D where the FATO is circular.

(See Figure 3-1.)

~~3.1.21 A safety area surrounding a FATO intended to be used by helicopters operated in performance class 2 or 3 in visual meteorological conditions (VMC) shall extend outwards from the periphery of the FATO for a distance of at least 3 m or 0.5 D, whichever is greater, of the largest helicopter the FATO is intended to serve and:~~

- ~~a) each external side of the safety area shall be at least 2 D where the FATO is quadrilateral; or~~
- ~~b) the outer diameter of the safety area shall be at least 2 D where the FATO is circular.~~

3.1.22~~23~~ There shall be a protected side slope rising at 45 degrees from the edge of the safety area to a distance of 10 m, whose surface shall not be penetrated by obstacles, except that when obstacles are located to one side of the FATO only, they may be permitted to penetrate the side slope surface.

Note.— When only a single approach and take-off climb surface is provided, the need for specific protected side slopes would be addressed in the aeronautical study required in 4.2.7.

~~3.1.23 A safety area surrounding a FATO intended to be used by helicopter operations in instrument meteorological conditions (IMC) shall extend:~~

- ~~a) laterally to a distance of at least 45 m on each side of the centre line; and~~
- ~~b) longitudinally to a distance of at least 60 m beyond the ends of the FATO.~~

(See Figure 3-1.)

3.1.24 No fixed **raised** object shall be permitted on a safety area, except for frangible objects, which, because of their function, must be located on the area. No mobile object shall be permitted on a safety area during helicopter operations.

~~3.1.25 Objects whose functions require them to be located on the safety area shall not exceed a height of 25 cm when located along the edge of the FATO nor penetrate a plane originating at a height of 25 cm above the edge of the FATO and sloping upwards and outwards from the edge of the FATO at a gradient of 5 per cent.~~

3.1.25 Objects whose function requires them to be located on the safety area shall not:

- a) if located at a distance of less than $0.75 D$ from the centre of the FATO, penetrate a plane at a height of 5 cm above the plane of the FATO; and
- b) if located at a distance of $0.75 D$ or more from the centre of the FATO, penetrate a plane originating at a height of 25 cm above the plane of the FATO and sloping upwards and outwards at a gradient of 5 per cent.

3.1.26 Recommendation. ~~In the case of a FATO of diameter less than $1 D$, the maximum height of the objects whose functions require them to be located on the safety area should not exceed a height of 5 cm.~~

Editorial Note.— Replace Figure 3-1 with new Figure 3-1 as follows:
(existing Figure 3-1 is relocated to Appendix 2 Figure A3-1)

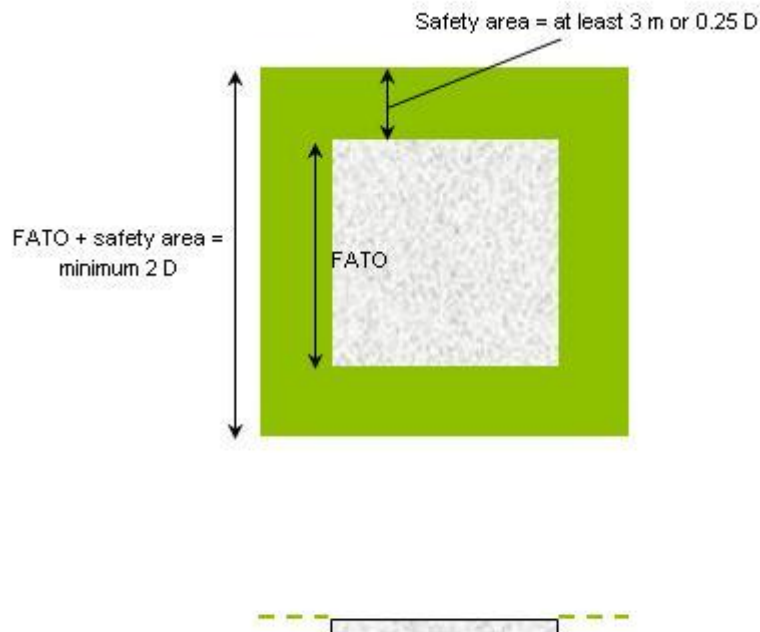

Figure 3-1. FATO and associated safety area

3.1.2726 The surface of the safety area, when solid, shall not exceed an upward slope of 4 per cent outwards from the edge of the FATO.

3.1.2827 Where applicable, the surface of the safety area shall be treated to prevent flying debris caused by rotor downwash.

3.1.2928 When solid, the surface of the safety area abutting the FATO shall be continuous with the FATO.

Helicopter ground taxiways and ground taxi-routes

Note 1.— A helicopter ground taxiway is intended to permit the surface movement of a wheeled helicopter under its own power.

Note 2.— The following specifications are intended for the safety of simultaneous operations during the manoeuvring of helicopters. However, the wind velocity induced by the rotor downwash might have to be considered.

Note 3.— When a taxiway is intended for use by aeroplanes and helicopters, the provisions for taxiways for aeroplanes and helicopter ground taxiways will be taken into consideration and the more stringent requirements will be applied.

3.1.3029 The width of a helicopter ground taxiway shall not be less than 1.5 times the largest width of the undercarriage (UCW) of the helicopters the ground taxiway is intended to serve (see Figure 3-2).

3.1.3130 The longitudinal slope of a helicopter ground taxiway shall not exceed 3 per cent.

3.1.3231 A helicopter ground taxiway shall be static load-bearing and be capable of withstanding the traffic of the helicopters the helicopter ground taxiway is intended to serve.

Editorial Note.— Replace Figure 3-2 with new Figure 3-2 as follows:

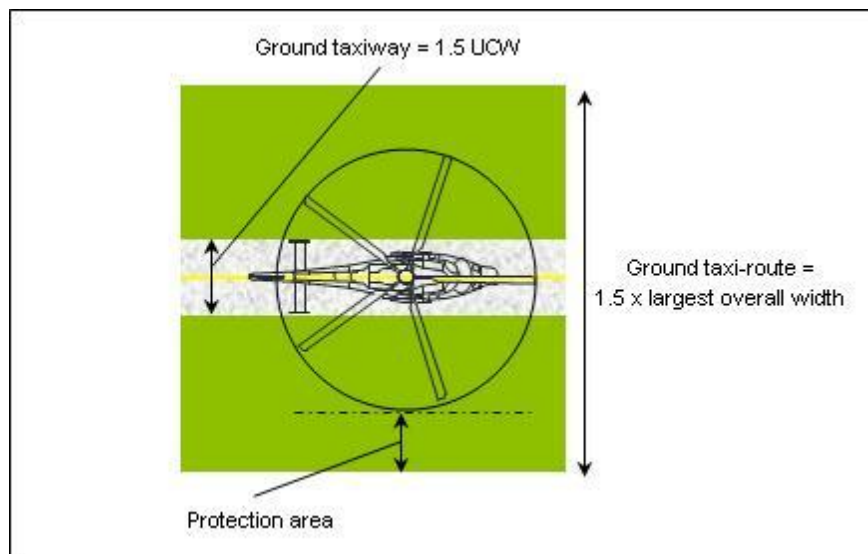

Figure 3-2. Helicopter ground taxi-route/taxiway

3.1.33~~32~~ A helicopter ground taxiway shall be centred on a ground taxi-route.

3.1.34~~33~~ A helicopter ground taxi-route shall extend symmetrically on each side of the centre line for at least 0.75 times the largest overall width of the helicopters it is intended to serve.

3.1.35~~34~~ No **fixed raised** objects shall be permitted on a helicopter ground taxi-route, except for frangible objects, which, because of their function, must be located thereon. **No mobile object shall be permitted on a ground taxi-route during helicopter movements.**

3.1.35 Objects whose function requires them to be located on a helicopter ground taxi-route shall not:

a) be located at a distance of less than 50 cm from the edge of the helicopter ground taxiway; and

b) penetrate a plane originating at a height of 25 cm above the plane of the taxiway, at a distance of 50 cm from the edge of the taxiway and sloping upwards and outwards at a gradient of 5 per cent.

3.1.36 The helicopter ground taxiway and the ground taxi-route shall provide rapid drainage but the helicopter ground taxiway transverse slope shall not exceed 2 per cent.

3.1.37 The surface of a helicopter ground taxi-route shall be resistant to the effect of rotor downwash.

3.1.38 For simultaneous operations, the helicopter ground taxi-routes shall not overlap.

Helicopter air taxiways and air taxi-routes

Note.— A helicopter air taxiway is intended to permit the movement of a helicopter above the surface at a height normally associated with ground effect and at ground speed less than 37km/h (20 kt).

3.1.38~~39~~ The width of a helicopter air taxiway shall be at least two times the largest width of the undercarriage (UCW) of the helicopters that the air taxiway is intended to serve (see Figure 3-3).

~~3.1.39—The surface of a helicopter air taxiway shall be suitable for an emergency landing.~~

3.1.40 **Recommendation.**— *The surface of a helicopter air taxiway should be static load-bearing.*

Editorial Note.— Replace Figure 3-3 with new Figure 3-3 as follows:

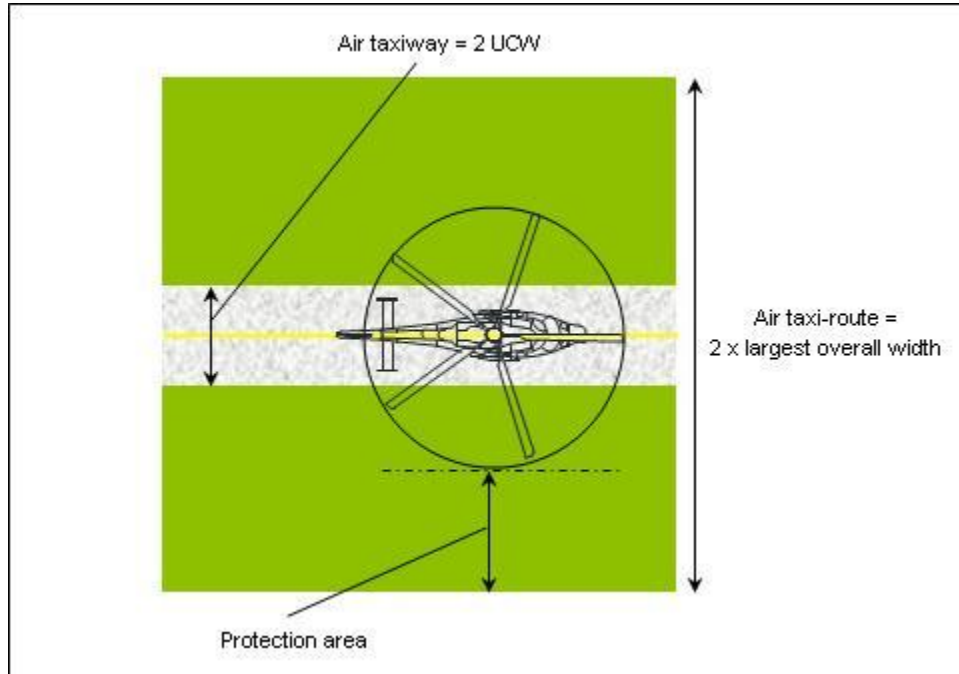

Figure 3-3. Helicopter air taxi-route/taxiway

3.1.41 **Recommendation.**— *The ~~transverse slopes~~ of the surface of a helicopter air taxiway should not exceed the slope landing limitations of the helicopters the air taxiway is intended to serve. In any event the transverse slope should not exceed 10 per cent and the longitudinal slope should not exceed 7 per cent. In any event, the slopes should not exceed the slope landing limitations of the helicopters the air taxiway is intended to serve.*

3.1.42 A helicopter air taxiway shall be centred on an air taxi-route.

3.1.43 A helicopter air taxi-route shall extend symmetrically on each side of the centre line for a distance at least equal to the largest overall width of the helicopters it is intended to serve.

3.1.44 No **fixed raised** objects shall be permitted on an air taxi-route, except for frangible objects, which, because of their function, must be located thereon. **No mobile object shall be permitted on an air taxi-route during helicopter movements.**

3.1.45 **Objects whose function requires them to be located on an air taxi-route shall not:**

- a) be located at a distance of less than 1 m from the edge of the air taxiway; and
- b) penetrate a plane originating at a height of 25 cm above the plane of the taxiway, at a distance of 1 m from the edge of the taxiway and sloping upwards and outwards at a gradient of 5 per cent.

3.1.46 **Recommendation.**— *Objects whose function requires them to be located on an air taxi-route should not:*

- a) be located at a distance of less than 0.5 of the largest overall width of the helicopter for which the

air taxi-route is designed from the centre line of the air taxiway; and

- b) *penetrate a plane originating at a height of 25 cm above the plane of the taxiway, at a distance of 0.5 of the largest overall width of the helicopter for which the air taxi-route is designed from the centre line of the taxiway, and sloping upwards and outwards at a gradient of 5 per cent.*

3.1.45⁴⁷ The surface of an air taxi-route shall be resistant to the effect of rotor downwash.

3.1.46⁴⁸ The surface of an air taxi-route shall provide ground effect.

3.1.49 For simultaneous operations, the air taxi-routes shall not overlap.

Air transit route

~~——— Note. — An air transit route is intended to permit the movement of a helicopter above the surface, normally at heights not above 30 m (100 ft) above ground level and at ground speeds exceeding 37 km/h (20 kt).~~

~~——— 3.1.47 The width of an air transit route shall not be less than:~~

~~—— a) 7.0 times the largest overall width of the helicopters the air transit route is intended to serve when the air transit route is intended for use by day only; and~~

~~—— b) 10.0 times the largest overall width of the helicopters the air transit route is intended to serve when the air transit route is intended for use at night.~~

~~——— 3.1.48 Any variation in the direction of the centre line of an air transit route shall not exceed 120 degrees and be designed so as not to necessitate a turn of radius less than 270 m.~~

~~——— Note. — It is intended that air transit routes be selected so as to permit autorotative or one-engine inoperative landings such that, as a minimum requirement, injury to persons on the ground or water, or damage to property are minimized.~~

Aprons Helicopter stands

Note. — The provisions of this section do not specify the location for helicopter stands but allow a high degree of flexibility in the overall design of the heliport. However, it is not considered good practice to locate helicopter stands under a flight path. See Heliport Manual (Doc 9261) for further guidance.

3.1.50 When a TLOF is collocated with a helicopter stand, the protection area of the stand shall not overlap the protection area of any other helicopter stand or associated taxi route.

3.1.49⁵¹ The helicopter stand shall provide rapid drainage but the slope in any direction on a helicopter stand shall not exceed 2 per cent.

Note. — The requirements on the dimensions of helicopter stands assume the helicopter will turn in a hover when operating over a stand.

3.1.50~~52~~ A helicopter stand intended to be used by helicopters turning in a hover shall be of sufficient size to contain a circle of diameter of at least 1.2 D of the largest helicopter the stand is intended to serve (see Figure 3-4).

3.1.51~~53~~ ~~When~~ Where a helicopter stand is intended to be used for taxi-through and where the helicopter using the stand is not required to turn, the minimum width of the stand and associated protection area shall be that of the taxi-route (see Figure 3-4).

3.1.52~~54~~ ~~When~~ Where a helicopter stand is intended to be used for turning, the minimum dimension of the stand and protection area shall be not less than 2 D (see Figure 3-5).

3.1.53~~55~~ ~~When~~ Where a helicopter stand is intended to be used for turning, it shall be surrounded by a protection area which extends for a distance of 0.4 D from the edge of the helicopter stand.

Editorial Note.— Delete Figure 3-4.

Editorial Note.— Replace Figure 3-5 with new Figure 3-4 as follows:

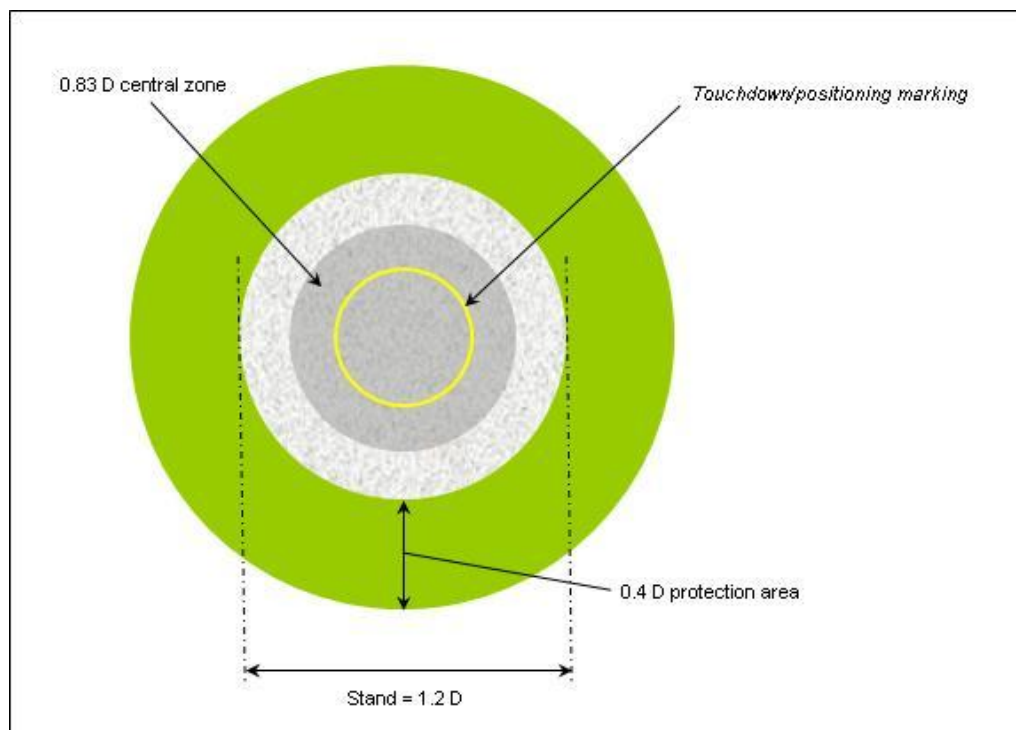

Figure 3-4. Helicopter stand and associated protection area

3.1.54~~56~~ For simultaneous operations, the protection areas of helicopter stands and their associated taxi-routes shall not overlap (see Figure 3-~~65~~).

Note.— Where non-simultaneous operations are envisaged, the protection areas of helicopter stands and their associated taxi-routes may overlap (see Figure 3-~~76~~).

~~3.1.55— When intended to be used for ground taxi operations by wheeled helicopters, the dimensions of a helicopter stand shall take into account the minimum turn radius of wheeled helicopters the stand is intended to serve.~~

3.1.56~~57~~ A helicopter stand and associated protection area intended to be used for air taxiing shall provide ground effect.

3.1.57~~58~~ No fixed raised objects shall be permitted on a helicopter stand and the associated protection area.

3.1.59 No fixed raised object shall be permitted in the protection area around a helicopter stand except for frangible objects, which because of their function, must be located there.

3.1.60 No mobile object shall be permitted on a helicopter stand and the associated protection area during helicopter movements.

3.1.61 Objects whose function requires them to be located in the protection area shall not:

- a) if located at a distance of less than 0.75 D from the centre of the helicopter stand, penetrate a plane at a height of 5 cm above the plane of the central zone; and
- b) if located at distance of 0.75 D or more from the centre of the helicopter stand, penetrate a plane at a height of 25 cm above the plane of the central zone and sloping upwards and outwards at a gradient of 5 per cent.

3.1.58~~62~~ The central zone of the a helicopter stand shall be capable of withstanding the traffic of helicopters that it is intended to serve and have a static load-bearing area:

- a) of diameter not less than 0.83 D of the largest helicopter it is intended to serve; or
- b) for a helicopter stand intended to be used for ground taxi-through, and where the helicopter using the stand is not required to turn, the same width as the ground-taxiway.

Note.— For a helicopter stand intended to be used for turning on the ground by wheeled helicopters, the dimension of the helicopter stand, including the dimension of the central zone, would may need to be significantly increased. See Heliport Manual (Doc 9261) for further guidance.

Editorial Note.— Replace Figure 3-6 with new Figure 3-5 as follows:

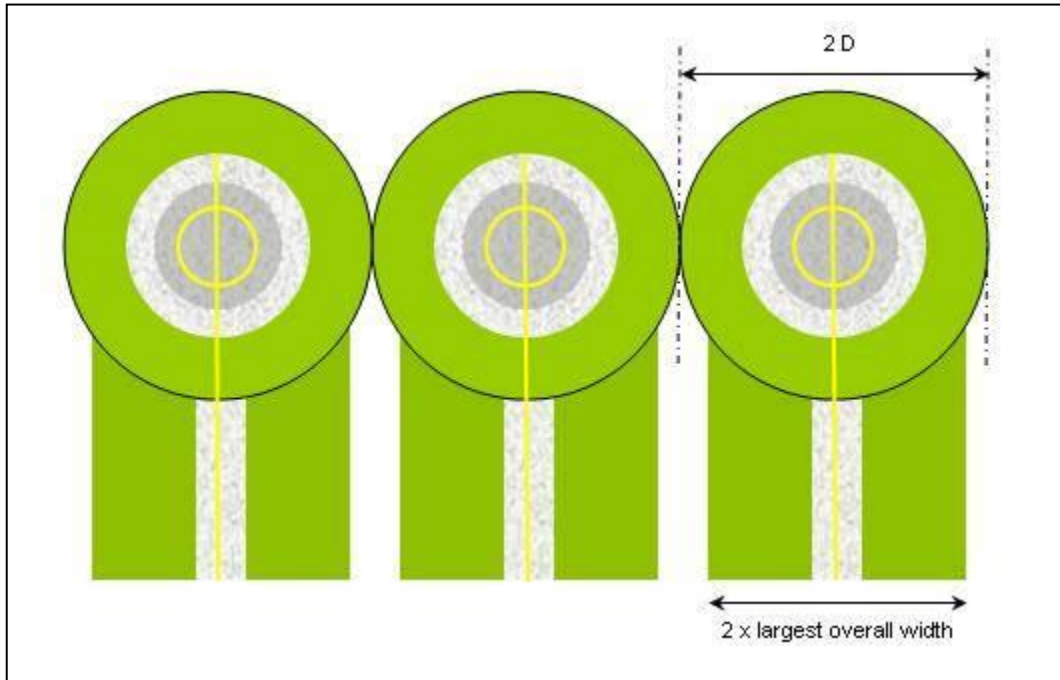

Figure 3-5. Helicopter stands designed for hover turns with air taxi-routes/taxiways — simultaneous operations

Editorial Note.— Replace Figure 3-7 with new Figure 3-6 as follows:

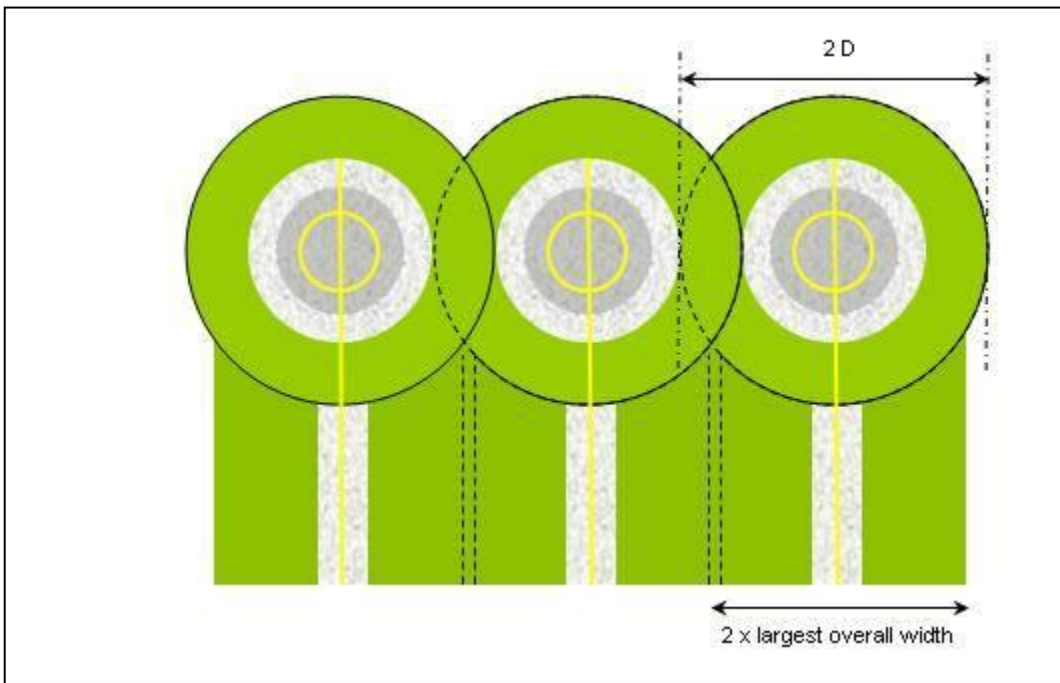

Figure 3-6. Helicopter stands designed for hover turns with

air taxi-routes/taxiways — non-simultaneous operations***Location of a final approach and take-off area
in relation to a runway or taxiway***

3.1.59~~63~~ Where a FATO is located near a runway or taxiway, and ~~where~~ simultaneous ~~VMC~~ operations are planned, the separation distance between the edge of a runway or taxiway and the edge of a FATO shall not be less than the appropriate dimension in Table 3-1.

3.1.60~~64~~ **Recommendation.**— *A FATO should not be located:*

- a) *near taxiway intersections or holding points where jet engine efflux is likely to cause high turbulence; or*
- b) *near areas where aeroplane vortex wake generation is likely to exist.*

Rationale

A recommendation and a note are added to address the need to consider the influence of the surrounding environment, including turbulence effects. Lack of any specific location considerations in the past has sometimes led to heliport operations being restricted or limited, perhaps for the entire operating life of the facility, due to the adverse influence of the surrounding environment.

The standard relating to the height of objects permitted on the safety area is made more demanding to better ensure the safety of helicopter operations over the FATO. It is intended to better protect helicopters from the risk of inadvertent strikes with essential fixtures that may need to be so located close to the edge of the FATO, such as FATO perimeter lights; small helicopters can be specifically endangered by an obstacle strike.

The standards relating to objects on helicopter ground and air taxi-routes more precisely describe the objects permitted by taking into account their distance to the associated taxiway (edge or centre). They are intended to better protect helicopters from the risk of inadvertent strikes with essential fixtures that may need to be so located close to the edges of the taxiway, such as taxiway edge lights; small helicopters can be specifically endangered by an obstacle strike.

The standards relating to objects on helicopter stands more precisely describe the objects permitted on stands by taking into account their distance to the centre of the stand. It is consistent with a similar requirement for the height of objects permitted on the safety area and is intended to allow essential fixtures that may need to be so located on the protection area, with a combination of height and proximity to the stand that ensure the safety of helicopters.

3.2 Elevated heliports

Note 1.—The dimensions of the taxi routes and helicopter stands include a protection area.

Note 2~~1~~.— Guidance on structural design for elevated heliports is given in the Heliport Manual (Doc 9261).

Note 2.— On elevated heliports it is presumed that the FATO and TLOF will be coincidental. Such an area, of which there may be one or more at an elevated heliport, is referred to as a “FATO/TLOF” in this section.

Note 3.— The provisions given in this section are based on the design assumption that no more than one helicopter will be in the FATO/TLOF at the same time.

Note 4.— The design provisions given in this section assume when conducting operations to a FATO/TLOF in proximity to another FATO/TLOF, these operations will not be simultaneous. If simultaneous helicopter operations are required, appropriate separation distances between FATO/TLOFs need to be determined, giving due regard to such issues as rotor downwash and airspace, and ensuring the flight paths for each FATO/TLOF, defined in Chapter 4, do not overlap.

Note 5.— The specifications for ground taxi-routes and air taxi-routes are intended for the safety of simultaneous operations during the manoeuvring of helicopters. However, the wind velocity induced by the rotor downwash might have to be considered.

3.2.1 In the case of elevated heliports, design considerations of the different elements of the heliport shall take into account additional loading resulting from the presence of personnel, snow, freight, refuelling, fire fighting equipment, etc.

Final approach and take-off areas and touchdown and lift-off areas

Note.—On elevated heliports it is presumed that the FATO and one TLOF will be coincidental.

3.2.2 An elevated heliport shall be provided with **at least** one FATO/TLOF.

3.2.3 A FATO/TLOF shall be obstacle free.

3.2.4 The dimensions of the FATO/TLOF shall be:

- a) where intended to be used by helicopters operated in performance class 1, as prescribed in the helicopter flight manual (HFM) except that, in the absence of width specifications, the width shall be not less than 1 D of the largest helicopter the FATO/TLOF is intended to serve;
- b) where intended to be used by helicopters operated in performance class 2 or 3, of sufficient size and shape to contain an area within which can be drawn a circle of diameter not less than:

- 1) 1 D of the largest helicopter when the MTOM of helicopters the FATO/TLOF is intended to serve is more than 3 175 kg;
- 2) 0.83 D of the largest helicopter when the MTOM of helicopters the FATO/TLOF is intended to serve is 3 175 kg or less.

3.2.5 **Recommendation.**— *Where intended to be used by helicopters operated in performance class 2 or 3 with MTOM of 3 175 kg or less, the FATO/TLOF should be of sufficient size and shape to contain an area within which can be drawn a circle of diameter not less than 1 D.*

Note.— *Local conditions, such as elevation and temperature, may need to be considered when determining the size of a FATO/TLOF. Guidance is given in the Heliport Manual (Doc 9261).*

3.2.6 Slopes on a the FATO/TLOF at an elevated heliport shall be sufficient to prevent accumulation of water on the surface of the area, but shall not exceed 2 per cent in any direction.

3.2.7 The FATO/TLOF shall be dynamic load-bearing.

3.2.8 The surface of the FATO/TLOF shall be:

- a) resistant to the effects of rotor downwash; and
- b) free of irregularities that would adversely affect the take-off or landing of helicopters.

3.2.9 **Recommendation.**— *The FATO/TLOF should provide ground effect.*

3.2.10 Safety devices such as safety nets or safety shelves shall be located around the edge of an elevated heliport but shall not exceed the FATO/TLOF height.

3.2.11 **Recommendation.**— *The FATO/TLOF should be located so as to minimize the influence of the surrounding environment, including turbulence, which could have an adverse impact on helicopter operations.*

Note.— *Specific guidance to determine if an air-gap under the heliport and/or some other turbulence mitigating design measure is necessary is given in the Heliport Manual (Doc 9261). If turbulence mitigating design measures are warranted but not practical, operational limitations may need to be considered under certain wind conditions.*

Helicopter clearways

a) —

~~3.2.10 When a helicopter clearway is provided, it shall be located beyond the end of the rejected take-off area available FATO/TLOF.~~

b) —

3.2.11 **Recommendation.**— *The width of a helicopter clearway should not be less than that of the associated safety area (see Figure 3-7).*

e) —

~~3.2.12 **Recommendation.** — When solid, the surface of the helicopter clearway should not project above a plane having an upward slope of 3 per cent, the lower limit of this plane being a horizontal line which is located on the periphery of the FATO/TLOF.~~

Editorial Note. — Move Table 3-1 after 3.1.64.

Table 3-1. FATO minimum separation distance

If aeroplane mass and/or helicopter mass are	Distance between FATO edge and runway edge or taxiway edge
up to but not including 3 175 kg	60 m
3 175 kg up to but not including 5 760 kg	120 m
5 760 kg up to but not including 100 000 kg	180 m
100 000 kg and over	250 m

~~3.2.13 **Recommendation.** — An object situated on in a helicopter clearway which may endanger helicopters in the air should be regarded as an obstacle and should be removed.~~

Touchdown and lift-off areas

~~3.2.14 One TLOF shall be coincidental with the FATO.~~

~~*Note.* — Additional TLOFs may be collocated with helicopter stands.~~

~~3.2.15 For a TLOF coincidental with the FATO, the dimensions and the characteristics of the TLOF shall be the same as those of the FATO.~~

~~3.2.16 When the TLOF is collocated with a helicopter stand, the TLOF shall be of sufficient size to contain a circle of diameter of at least 0.83 D of the largest helicopter the area is intended to serve.~~

~~3.2.17 Slopes on a TLOF collocated with a helicopter stand shall be sufficient to prevent accumulation of water on the surface of the area, but shall not exceed 2 per cent in any direction.~~

~~3.2.18 When the TLOF is collocated with a helicopter stand and intended to be used by ground taxiing helicopters only, the TLOF shall at least be static load bearing and be capable of withstanding the traffic of the helicopters the area is intended to serve.~~

~~3.2.19~~ When the TLOF is collocated with a helicopter stand and intended to be used by air taxiing helicopters, the TLOF shall have a dynamic load bearing area.

Safety areas

3.2.20~~12~~ The FATO/TLOF shall be surrounded by a safety area which need not be solid.

3.2.21~~13~~ A safety area surrounding a FATO/TLOF ~~intended to be used by helicopters operated in performance class 1 in visual meteorological conditions (VMC)~~ shall extend outwards from the periphery of the FATO/TLOF for a distance of at least 3 m or 0.25 D, whichever is greater, of the largest helicopter the FATO/TLOF is intended to serve and:

- a) each external side of the safety area shall be at least 2 D where the FATO/TLOF is quadrilateral; or
- b) the outer diameter of the safety area shall be at least 2 D where the FATO/TLOF is circular.

(See Figure 3-7.)

~~3.2.22~~ A safety area surrounding a FATO intended to be used by helicopters operated in performance class 2 or 3 in visual meteorological conditions (VMC) shall extend outwards from the periphery of the FATO for a distance of at least 3 m or 0.5 D, whichever is the greater, of the largest helicopter the FATO is intended to serve and:

- ~~a) each external side of the safety area shall be at least 2 D where the FATO is quadrilateral; or~~
- ~~b) the outer diameter of the safety area shall be at least 2 D where the FATO is circular.~~

3.2.23~~14~~ There shall be a protected side slope rising at 45 degrees from the edge of the safety area to a distance of 10 m, whose surface shall not be penetrated by obstacles, except that when obstacles are located to one side of the FATO/TLOF only, they may be permitted to penetrate the side slope surface.

Note.— When only a single approach and take-off climb surface is provided, the need for specific protected side slopes would be addressed in the aeronautical study required in 4.2.10.

3.2.24~~15~~ No fixed raised object shall be permitted on a safety area, except for frangible objects, which, because of their function, must be located on the area. No mobile object shall be permitted on a safety area during helicopter operations.

~~3.2.25~~ Objects whose function require them to be located on the safety area shall not exceed a height of 25 cm when located along the edge of the FATO nor penetrate a plane originating at a height of 25 cm above the edge of the FATO and sloping upwards and outwards from the edge of the FATO at a gradient of 5 per cent.

3.2.16 Objects whose function requires them to be located on the safety area shall not:

- a) if located at a distance of less than 0.75 D from the centre of the FATO/TLOF, penetrate a plane

at a height of 5 cm above the plane of the FATO/TLOF; and

- b) if located at a distance of $0.75 D$ or more from the centre of the FATO/TLOF, penetrate a plane originating at a height of 25 cm above the plane of the FATO/TLOF and sloping upwards and outwards at a gradient of 5 per cent.

3.2.26 **Recommendation.**— *In the case of a FATO of diameter less than $1 D$, the maximum height of the objects whose functions require them to be located on the safety area should not exceed a height of 5 cm.*

Editorial Note.— Insert new Figure 3-7 as follows:

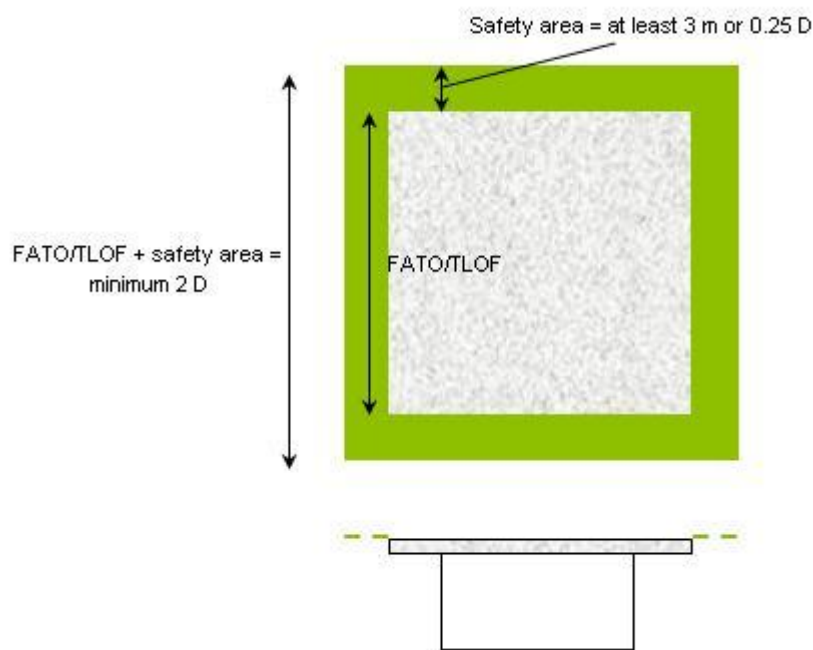

Figure 3-7. FATO/TLOF and associated safety area

3.2.2717 The surface of the safety area, when solid, shall not exceed an upward slope of 4 per cent outwards from the edge of the FATO/TLOF.

3.2.2818 Where applicable, the surface of the safety area shall be prepared in a manner to prevent flying debris caused by rotor downwash.

3.2.2919 When solid, the surface of the safety area abutting the FATO/TLOF shall be continuous with the FATO/TLOF.

Helicopter ground taxiways and ground taxi-routes

Note.— The following specifications are intended for the safety of simultaneous operations during the manoeuvring of helicopters. However, the wind velocity induced by the rotor downwash might have to be considered.

3.2.3020 The width of a helicopter ground taxiway shall not be less than 2 times the largest width of the undercarriage (UCW) of the helicopters the ground taxiway is intended to serve (see Figure 3-8).

3.2.3121 The longitudinal slope of a helicopter ground taxiway shall not exceed 3 per cent.

3.2.3222 A helicopter ground taxiway shall be static load-bearing and be capable of withstanding the traffic of the helicopters the helicopter ground taxiway is intended to serve.

Editorial Note.— Insert new Figure 3-8 as follows:

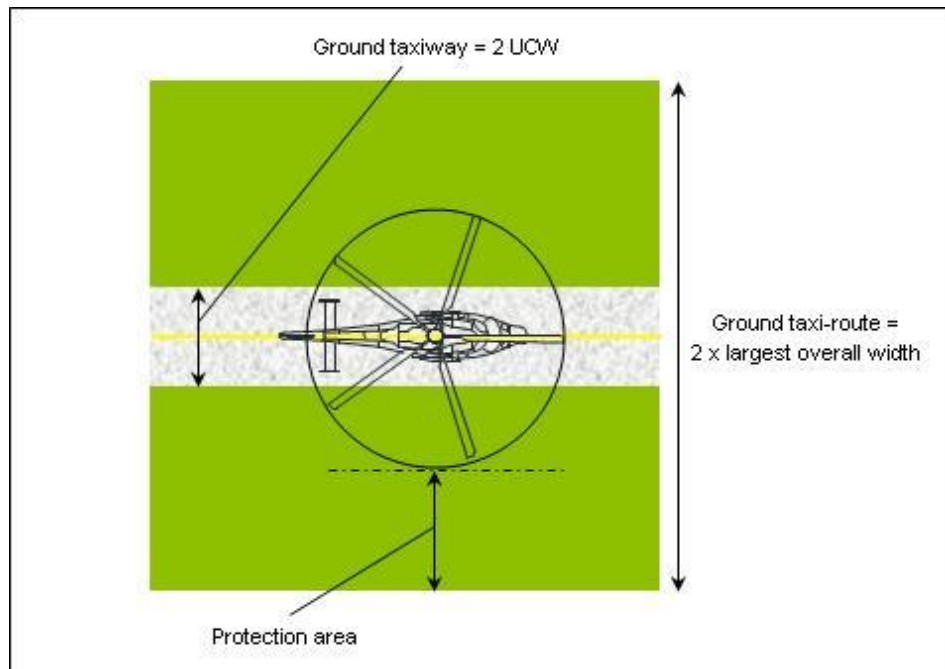

Figure 3-8. Helicopter ground taxi-route/taxiway

3.2.33²³ A helicopter ground taxiway shall be centred on a ground taxi-route.

3.2.34²⁴ A helicopter ground taxi-route shall extend symmetrically on each side of the centre line to a distance not less than the largest overall width of the helicopters it is intended to serve.

3.2.35²⁵ No fixed raised objects shall be permitted on a helicopter ground taxi-route, except for frangible objects, which, because of their function, must be located thereon. No mobile object shall be permitted on a ground taxi-route during helicopter movements.

3.2.26 Objects whose function requires them to be located on a helicopter ground taxi-route shall not:

- a) be located at a distance of less than 50 cm from the edge of the helicopter ground taxiway; and
- b) penetrate a plane originating at a height of 25 cm above the plane of the taxiway, at a distance of 50 cm from the edge of the taxiway and sloping upwards and outwards at a gradient of 5 per cent.

3.2.36²⁷ The helicopter ground taxiway and the ground taxi-route shall provide rapid drainage but the helicopter ground taxiway transverse slope shall not exceed 2 per cent.

3.2.37²⁸ The surface of a helicopter ground taxi-route shall be resistant to the effect of rotor downwash.

3.2.29 For simultaneous operations, the helicopter ground taxi-routes shall not overlap.

Helicopter air taxiways and air taxi-routes

Note.— A helicopter air taxiway is intended to permit the movement of a helicopter above the surface at a height normally associated with ground effect and at ground speed less than 37 km/h (20 kt).

3.2.38³⁰ The width of a helicopter air taxiway shall be at least three times the largest width of the undercarriage (UCW) of the helicopters the air taxiway is intended to serve (see Figure 3-9).

3.2.39³¹ The surface of a helicopter air taxiway shall be dynamic load-bearing.

Editorial Note.— Insert new Figure 3-9 as follows:

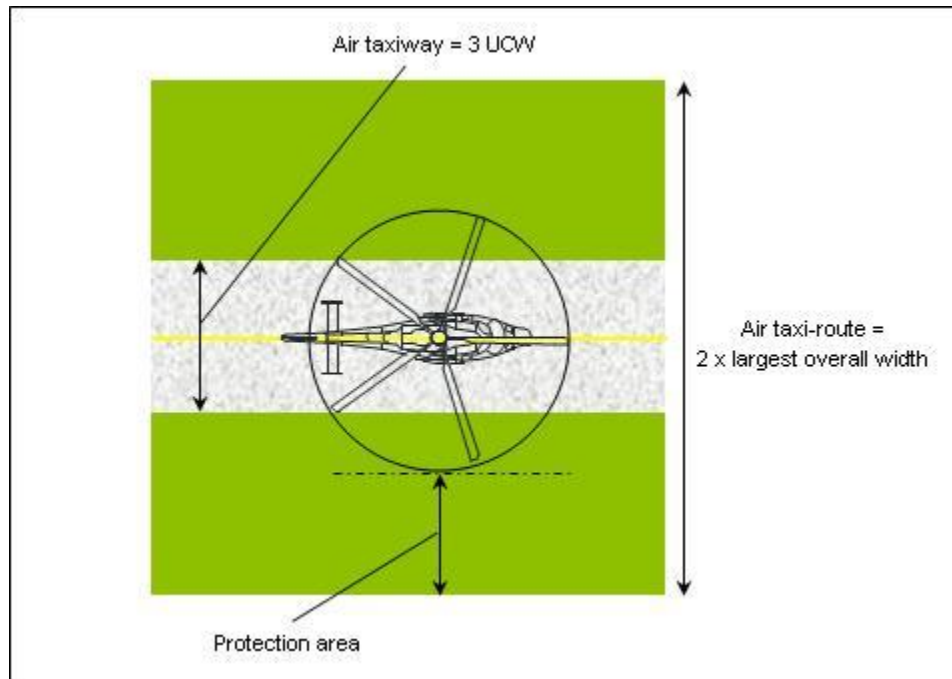

Figure 3-9. Helicopter air taxi-route/taxiway

3.2.4032 The transverse slopes of the surface of a helicopter air taxiway shall not exceed the slope landing limitations of the helicopters the air taxiway is intended to serve. In any event the transverse slope shall not exceed 2 per cent and the longitudinal slope shall not exceed 7 per cent. ~~In any event, the slopes shall not exceed the slope landing limitations of the helicopters the air taxiway is intended to serve.~~

3.2.4133 A helicopter air taxiway shall be centred on an air taxi-route.

3.2.4234 A helicopter air taxi-route shall extend symmetrically on each side of the centre line to a distance not less than the largest overall width of the helicopters it is intended to serve.

3.2.4335 No fixed raised objects shall be permitted on an air taxi-route, except for frangible objects, which, because of their function, must be located thereon. No mobile object shall be permitted on an air taxi-route during helicopter movements.

3.2.36 Objects whose function requires them to be located on an air taxi-route shall not:

- a) be located at a distance of less than 1 m from the edge of the air taxiway; and
- b) penetrate a plane originating at a height of 25 cm above the plane of the taxiway, at a distance of 1 m from the edge of the taxiway and sloping upwards and outwards at a gradient of 5 per cent.

3.2.37 **Recommendation.**— *Objects whose function requires them to be located on an air taxi-route should not:*

- a) *be located at a distance of less than 0.5 of the largest overall width of the helicopter for which designed from the centre line of the air taxiway; and*
- b) *penetrate a plane originating at a height of 25 cm above the plane of the taxiway, at a distance of 0.5 of the largest overall width of the helicopter for which designed from the centre line of the taxiway, and sloping upwards and outwards at a gradient of 5 per cent.*

3.2.44~~38~~ The surface of an air taxi-route shall be resistant to the effect of rotor downwash.

3.2.45~~39~~ The surface of an air taxi-route shall provide ground effect.

3.2.40 For simultaneous operations, the air taxi-routes shall not overlap.

Aprons—Helicopter stands

Note.— *The provisions of this section do not specify the location for helicopter stands but allow a high degree of flexibility in the overall design of the heliport. However, it is not considered good practice to locate helicopter stands under a flight path. See Heliport Manual (Doc 9261) for further guidance.*

3.2.46~~41~~ The helicopter stand shall provide rapid drainage but the slope in any direction ~~on a helicopter stand~~ shall not exceed 2 per cent.

Note.— *The requirements on the dimensions of helicopter stands assume the helicopter will turn in a hover when operating over a stand.*

3.2.47~~42~~ A helicopter stand intended to be used by helicopter turning in a hover shall be of sufficient size to contain a circle of diameter of at least 1.2 D of the largest helicopters the stand is intended to serve (see Figure 3-4).

3.2.48~~43~~ ~~If~~ ~~Where~~ a helicopter stand is intended to be used for taxi-through and where the helicopter using the stand is not required to turn, the minimum width of the stand and associated protection area shall be that of the taxi-route.

3.2.49~~44~~ ~~When~~ ~~Where~~ a helicopter stand is intended to be used for turning, the minimum dimension of the stand and protection area shall be not less than 2 D.

3.2.50~~45~~ ~~When~~ ~~Where~~ a helicopter stand is intended to be used for turning, it shall be surrounded by a protection area which extends for a distance of 0.4 D from the edge of the helicopter stand.

3.2.51~~46~~ For simultaneous operations, the protection areas of helicopter stands and their associated taxi-routes shall not overlap (see Figure 3-5).

Note.— *Where non-simultaneous operations are envisaged, the protection areas of helicopter stands and their associated taxi-routes may overlap (see Figure 3-6).*

~~3.2.52 When intended to be used for ground taxi operations by wheeled helicopters, the dimensions of a helicopter stand shall take into account the minimum turn radius of the wheeled helicopters the stand is intended to serve.~~

3.2.53⁴⁷ A helicopter stand and associated protection area intended to be used for air taxiing shall provide ground effect.

3.2.54⁴⁸ No fixed raised objects shall be permitted on a helicopter stand ~~and the associated protection area.~~

3.2.49 No fixed raised object shall be permitted in the protection area around a helicopter stand except for frangible objects, which because of their function, must be located there.

3.2.50 No mobile object shall be permitted on a helicopter stand and the associated protection area during helicopter movements.

3.2.51 Objects whose function requires them to be located in the protection area shall not:

- a) if located at a distance of less than 0.75 D from the centre of the helicopter stand, penetrate a plane at a height of 5 cm above the plane of the central zone; and
- b) if located at distance of 0.75 D or more from the centre of the helicopter stand, penetrate a plane at a height of 25 cm above the plane of the central zone and sloping upwards and outwards at a gradient of 5 per cent.

3.2.55⁵² The central zone of ~~the a~~ helicopter stand shall be capable of withstanding the traffic of the helicopters it is intended to serve and have a load-bearing area:

- a) of diameter not less than 0.83 D of the largest helicopter it is intended to serve; or
- b) for a helicopter stand intended to be used for ground taxi-through, and where the helicopter using the stand is not required to turn, the same width as the ground-taxiway.

3.2.56⁵³ The central zone of a helicopter stand intended to be used for ground taxiing only shall be static load-bearing.

3.2.57⁵⁴ The central zone of a helicopter stand intended to be used for air taxiing shall be dynamic load-bearing.

Note.— For a helicopter stand intended to be used for turning on the ground by wheeled helicopters, the dimension of the helicopter stand, including the dimension of the central zone, would need ~~might have to be~~ significantly increased. See Heliport Manual (Doc 9261) for further guidance.

Rationale

On an elevated heliport it is assumed that the FATO and TLOF will always be coincidental. Editorial amendments are now made to cover this combined area referred to throughout a single section as “FATO/TLOF”.

A requirement to provide safety devices, such as safety nets or safety shelves, around the heliport perimeter for the protection of personnel is added as a standard. It is consistent with a similar requirement for safety devices already specified for helidecks and is intended to provide for the protection of personnel who might otherwise be at risk of falling straight into space.

A recommendation and a note are added to address the need to consider the influence of the surrounding environment, including turbulence. Lack of any specific location considerations in the past has sometimes led to heliport operations being restricted or limited, perhaps for the entire operating life of the facility, due to the adverse influence of the surrounding environment.

It is recognised that a helicopter clearway at ground level would not be appropriate at an elevated heliport for the case where helicopters are operating in performance class 1; indeed such operations set that the helicopter may fly (one engine inoperative) below the level of the heliport. In consideration of this the entire section relating to helicopter clearways is removed.

The standard relating to the height of objects permitted on the safety area is made more demanding to better ensure the safety of helicopter operations over the FATO. It is intended to better protect helicopters from the risk of inadvertent strikes with essential fixtures that may need to be so located close to the edge of the FATO, such as FATO perimeter lights; small helicopters can be specifically endangered by an obstacle strike.

The standards relating to objects on helicopter ground and air taxi-routes more precisely describe the objects permitted by taking into account their distance to the associated taxiway (edge or centre). They are intended to better protect helicopters from the risk of inadvertent strikes with essential fixtures that may need to be so located close to the edges of the taxiway, such as taxiway edge lights; small helicopters can be specifically endangered by an obstacle strike.

The standards relating to objects on helicopter stands more precisely describe the objects permitted on stands by taking into account their distance to the centre of the stand. It is consistent with a similar requirement for the height of objects permitted on the safety area and is intended to allow essential fixtures that may need to be so located on the protection area, with a combination of height and proximity to the stand that ensure the safety of helicopters.

3.3 Helidecks

Note.— The following specifications are for helidecks located on structures engaged in such activities as mineral exploitation, research or construction. See 3.4 for shipboard heliport provisions.

Final approach and take-off area and touchdown and lift-off area

Note.— On helidecks it is presumed that the FATO and the TLOF will occupy the same space and have the same load bearing characteristics ~~be coincidental~~. Therefore any application Reference to FATO within the helideck section of this Annex is assumed automatically to include the TLOF so the combined term FATO/TLOF is used. Guidance on the effects of airflow direction and turbulence, prevailing wind velocity and high temperatures from gas turbine exhausts or flare-radiated heat on the location of the FATO/TLOF is given in the Heliport Manual (Doc 9261).

3.3.1 The specifications in paragraphs 3.3.9¹³ and 3.3.10¹⁴ shall be applicable for helidecks completed on or after 1 January 2012.

3.3.2 A helideck shall be provided with ~~at least~~ one FATO/TLOF.

3.3.3 A FATO/TLOF may be any shape but shall be of sufficient size to contain:

a) for helicopters with a MTOM of more than 3175 kg, an area within which can be accommodated a circle of diameter of not less than 1.0 D of the largest helicopter the helideck is intended to serve; and

b) for helicopters with a MTOM of 3175 kg or less, an area within which can be accommodated a circle of diameter of not less than 0.83 D of the largest helicopter the helideck is intended to serve.

3.3.4 **Recommendation.** *For helicopters with a MTOM of 3175 kg or less, the FATO/TLOF should be of sufficient size to contain an area within which can be accommodated a circle of diameter of not less than 1.0 D of the largest helicopter the helideck is intended to serve.*

3.3.5 A helideck shall be arranged to ensure that a sufficient and unobstructed air-gap is provided which encompasses the full dimensions of the FATO/TLOF.

Note.- Specific guidance on the characteristics of an air-gap is given in the Heliport Manual (Doc 9261). As a general rule, except for shallow superstructures of three stories or less, a sufficient air-gap will be at-least 3m.

3.3.6 **Recommendation.** *The FATO/TLOF should be located so as to avoid, as far as is practicable, the influence of environmental effects, including turbulence, over the FATO/TLOF, which could have an adverse impact on helicopter operations.*

3.3.5⁷ A FATO/TLOF shall be dynamic load-bearing.

3.3.6⁸ A FATO/TLOF shall provide ground effect.

3.3.79 No fixed object shall be permitted around the edge of the FATO/TLOF except for frangible objects, which, because of their function, must be located thereon.

3.3.810 For any FATO/TLOF having a D-value of greater than 16.0m, ~~Q~~ objects in the obstacle free sector whose function requires them to be located on the edge of the FATO/TLOF shall not exceed a height of 25 cm., ~~except that in the case of a FATO of diameter less than 1D the maximum height of such objects shall not exceed a height of 5 cm.~~

3.3.11 For any FATO/TLOF having a D-value of 16.0m or less, objects in the obstacle free sector whose function requires them to be located on the edge of the FATO/TLOF, shall not exceed a height of 5 cm.

3.3.12 For any FATO/TLOF having dimensions of less than 1D, the maximum height of such objects in the obstacle free sector whose function requires them to be located on the edge of the FATO/TLOF shall not exceed a height of 5 cm.

Note.- Lighting that is mounted at a height of less than 25 cm is typically assessed for adequacy of visual cues before and after installation.

3.3.913 Objects whose function requires them to be located within the FATO/TLOF (such as lighting or nets) shall not exceed a height of 2.5 cm. Such objects ~~may~~ shall only be present ~~only~~ if they do not represent a hazard to helicopters.

Note.- Examples of potential hazards include nets or raised fittings on the deck that might induce dynamic rollover for helicopters equipped with skids.

3.3.4014 Safety devices such as safety nets or safety shelves shall be located around the edge of a helideck but shall not exceed the helideck height of the FATO/TLOF.

3.3.415 The surface of the FATO/TLOF shall be skid-resistant to both helicopters and persons and be sloped to prevent pooling of water.

Note.- Guidance on rendering the surface of the FATO/TLOF skid-resistant is contained in the Heliport Manual (Doc 9261).

Rationale

On a helideck it is assumed that the FATO and TLOF will always be coincidental. Editorial amendments are now made to cover this combined area referred to throughout the section as “FATO/TLOF”.

A Standard, a Recommendation and a Note are added to address the need to consider the influence of the surrounding environment, including turbulence effects. To promote

beneficial wind flow over the helideck an unobstructed air-gap is specified. The location of the helideck relative to all aspects of the topside arrangement should take account of the need to minimise any effects of the surrounding environment on helicopter operations. Lack of any specific design considerations in the past has led to poorly designed and/or located topside arrangements, which have often led to helideck operations being restricted or limited, perhaps for the entire operating life of a fixed or floating facility, due to the adverse influence of the surrounding environment.

The standards relating to the height of objects permitted around the edge of the FATO/TLOF, in the obstacle free sector, are extended for smaller helicopter types to better ensure the safety of helicopter operations at the helideck - new standards now capture all FATO/TLOFs where the D value is 16.0m or less regardless of whether this equates to 1D, or is less than 1D, for the design helicopter. The new more demanding standards relating to objects around the edge of the FATO/TLOF, in the obstacle free sector, are intended to protect a larger range of smaller (mainly skid fitted) helicopter types from the risk of inadvertent strikes with essential fixtures that may need to be so located around the FATO/TLOF. A trawl of incidents and accidents around the world has indicated a number of obstacle strikes due to the combination of height and the proximity of essential objects to the touchdown location.

3.4 Shipboard heliports

3.4.1 The specifications in paragraph 3.4.11 and 3.4.16 shall be applicable to shipboard heliports completed on or after 1 January 2012 and 1 January 2015 respectively.

3.4.2 When helicopter operating areas are provided in the bow or stern of a ship or are purpose-built above the ship's structure, they shall be regarded as purpose-built shipboard heliports.

Final approach and take-off area and touchdown and lift-off area

Note.— On shipboard heliports it is presumed that the FATO and the TLOF will occupy the same space and have the same load bearing characteristics be coincidental. Therefore any application Reference to FATO within the shipboard heliport section of this Annex is assumed automatically to include the TLOF so the combined term FATO/TLOF is used. Guidance on the effects of airflow direction and turbulence, prevailing wind velocity and high temperature from gas turbine exhausts or flare-radiated heat on the location of the FATO/TLOF is given in the Heliport Manual (Doc 9261).

3.4.3 A Shipboard heliports shall be provided with at least one FATO/TLOF.

3.4.4 The FATO/TLOF of a shipboard heliport shall be dynamic load-bearing.

3.4.5 The FATO/TLOF of a shipboard heliport shall provide ground effect.

3.4.6 For purpose-built shipboard heliports provided in a location other than the bow or stern, the FATO/TLOF shall be of sufficient size to contain a circle with a diameter not less than 1.0 D of the largest helicopter the heliport is intended to serve.

3.4.7 For purpose-built shipboard heliports provided in the bow or stern of a ship, the FATO/TLOF shall be of sufficient size to:

a) contain a circle with a diameter not less than 1 D of the largest helicopter the heliport is intended to serve; or

b) for operations with limited touchdown directions, contain an area within which can be accommodated two opposing arcs of a circle with a diameter of not less than 1D in the helicopter's longitudinal direction. The minimum width of the heliport shall be not less than 0.83D (See Figure 3.810).

Note 1 — The ship will need to be manoeuvred to ensure that the relative wind is appropriate to the direction of the helicopter touchdown heading.

Note 2 — The touchdown heading of the helicopter is limited to the angular distance subtended by the 1 D arcs headings, minus the angular distance which corresponds to 15 degrees at each end of the arc.

3.4.8 For non-purpose built shipboard heliports, the FATO/TLOF shall be of sufficient size to contain a circle with a diameter not less than 1D of the largest helicopter the helideck is intended to serve.

3.4.9 A shipboard heliport shall be arranged to ensure that a sufficient and unobstructed air-gap is provided which encompasses the full dimensions of the FATO/TLOF.

Note.- Specific guidance on the characteristics of an air-gap is given in the Heliport Manual (doc 9261). As a general rule, except for shallow superstructures of three stories or less, a sufficient air-gap will be at-least 3m.

3.4.10 **Recommendation.** *The FATO/TLOF should be located so as to avoid, as far as is practicable, the influence of environmental effects, including turbulence, over the FATO/TLOF, which could have an adverse impact on helicopter operations.*

3.4.911 No fixed object shall be permitted around the edge of the FATO/TLOF except for frangible objects, which, because of their function, must be located thereon.

3.4.1012 For any FATO/TLOF having a D-value of greater than 16.0m, Θ -objects in the obstacle free sector whose function requires them to be located on the edge of the FATO/TLOF shall not exceed a height of 25 cm.

3.4.13 For any FATO/TLOF having a D-value of 16.0m or less, objects in the obstacle free sector, whose function requires them to be located on the edge of the FATO/TLOF, shall not exceed a height of 5 cm.

3.4.14 For any FATO/TLOF having dimensions of less than 1D, the maximum height of such objects in the obstacle free sector whose function requires them to be located on the edge of the FATO/TLOF shall not exceed a height of 5 cm.

Note.— Lighting that is mounted at a height of less than 25 cm is typically assessed for adequacy of visual cues before and after installation.

3.4.11~~15~~ Objects whose function requires them to be located within the FATO/TLOF (such as lighting or nets) shall not exceed a height of 2.5 cm. Such objects ~~may~~ shall only be present ~~only~~ if they do not represent a hazard to helicopters.

3.4.16 Safety devices such as safety nets or safety shelves shall be located around the edge of a shipboard heliport, except where structural protection exists, but shall not exceed the height of the FATO/TLOF.

3.4.12~~17~~ The surface of the FATO/TLOF shall be skid-resistant to both helicopters and persons.

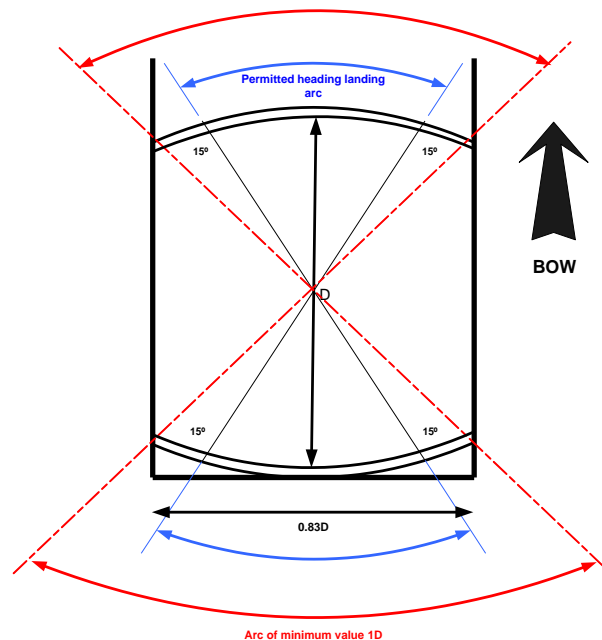

Figure 3-8~~10~~. Shipboard permitted landing headings for limited heading operations

Rationale

On a shipboard heliport it is assumed that the FATO and TLOF will always be coincidental. Editorial amendments are now made to cover this combined area referred to throughout the section as “FATO/TLOF”.

A requirement to provide safety devices, such as safety nets or safety shelves, around the heliport perimeter, except where structural protection exists, is added as a standard; it is consistent with a similar requirement for safety devices already specified for helidecks and is intended to provide for the protection of personnel who might otherwise be at risk of slipping, tripping or a falling straight into the sea.

A Standard, a Recommendation and a Note are added to address the need to consider the influence of the surrounding environment, including turbulence effects. To promote beneficial wind flow over the shipboard heliport an unobstructed air-gap is specified. The location of the heliport relative to all aspects of a ship's topside arrangement should take account of the need to minimise any effects of the surrounding environment on helicopter operations. Lack of any specific design considerations in the past has led to poorly designed and/or poorly located shipboard heliports, which have often led to operations being restricted or limited, perhaps for the entire operating life of a ship, due to the adverse influence of the surrounding environment.

The standards relating to the height of objects permitted around the edge of the FATO/TLOF, in the obstacle free sector, are extended for smaller helicopter types to better ensure the safety of helicopter operations at a shipboard heliport - new standards now capture all FATO/TLOFs where the D value is 16.0m or less regardless of whether this equates to 1D, or is less than 1D, for the design helicopter. The new more demanding standards relating to objects around the edge of the FATO/TLOF, in the obstacle free sector, are intended to protect a larger range of smaller (mainly skid fitted) helicopter types from the risk of inadvertent strikes with essential fixtures that may need to be so located around the FATO/TLOF. A trawl of incidents and accidents around the world has indicated a number of obstacle strikes due to a combination of height and the proximity of essential objects to the touchdown location.

CHAPTER 4. OBSTACLE ENVIRONMENT RESTRICTION AND REMOVAL

Note. — *The objectives of the specifications in this chapter are to ~~define~~ describe the airspace around heliports ~~to be maintained free from obstacles~~ so as to permit the intended helicopter operations ~~at the heliports~~ to be conducted safely and to prevent, where appropriate State controls exist, ~~the heliports from becoming unusable by the growth of obstacles around them.~~ This is achieved by establishing a series of obstacle limitation surfaces that define the limits to which objects may project into the airspace.*

4.1 Obstacle limitation surfaces and sectors

Approach surface

4.1.1 *Description.* An inclined plane or a combination of planes or, when a turn is involved, a complex surface sloping upwards from the end of the safety area and centred on a line passing through the centre of the FATO (see Figure 4-1) (or FATO/TLOF). There is an option for heliports intended to be used by helicopters operated in performance class 1 and when approved by an appropriate authority, to raise the origin of the inclined plane directly above the safety area.

Note 1.- See Heliport Manual (Doc 9261) for guidance.

Note 2. — See Figure 4-1, 4-2, 4-3 and 4-4 for depiction of surfaces. See Table 4-1 for dimensions and slopes of surfaces.

4.1.2 *Characteristics.* The limits of an approach surface shall comprise:

- a) an inner edge horizontal and equal in length to the minimum specified width of the FATO (or FATO/TLOF) plus the safety area, perpendicular to the centre line of the approach surface and located at the outer edge of the safety area;
- b) two side edges originating at the ends of the inner edge diverging uniformly at a specified rate from the vertical plane containing the centre line of the FATO (or FATO/TLOF); and
 - 1) ~~for other than a precision approach FATO, diverging uniformly at a specified rate from the vertical plane containing the centre line of the FATO~~
 - 2) ~~for a precision approach FATO, diverging uniformly at a specified rate from the vertical plane containing the centre line of the FATO, to a specified height above FATO, and then diverging uniformly at a specified rate to a specified final width and continuing thereafter at that width for the remaining length of the approach surface; and~~
- c) an outer edge horizontal and perpendicular to the centre line of the approach surface and at a specified height of 152 m (500 ft) above the elevation of the FATO (or FATO/TLOF) .

4.1.3 The elevation of the inner edge shall be the elevation of the safety area FATO (or FATO/TLOF) at the point on the inner edge that is intersected by the centre line of the approach surface.

4.1.4 The slope(s) of the approach surface shall be measured in the vertical plane containing the centre line of the surface.

4.1.5 In the case of an approach surface involving a turn, the surface shall be a complex surface containing the horizontal normal's to its centre line and the slope of the centre line shall be the same as that for a straight take-off climb surface.

Note. – See Figure 4-5

4.1.6 In the case of an approach surface involving a turn, the surface shall not contain more than one curved portion.

4.1.7 Where a curved portion of an approach surface is provided the sum of the radius of arc defining the centre line of the approach surface and the length of the straight portion originating at the inner edge shall not be less than 575 m.

4.1.8 Any variation in the direction of the centre line of an approach surface shall be designed so as not to necessitate a turn radius less than 270 m.

Note.- For heliports intended to be used by helicopters operated in performance class 2 and 3, it is intended good practice for the that approach paths to be selected so as to permit safe forced landing or one-engine-inoperative landings such that, as a minimum requirement, injury to persons on the ground or water or damage to property are minimized. Provisions for forced landing areas are expected to minimize risk of injury to the occupants of the helicopter. The most critical helicopter type for which the heliport is intended and the ambient conditions will may be factors in determining the suitability of such areas.

Transitional surface

Note. – For a FATO (or FATO/TLOF) at a heliport without a PinS approach incorporating a visual segment surface (VSS) there is no requirement to provide transitional surfaces.

4.1.5 ⁹ *Description.* A complex surface along the side of the safety area and part of the side of the approach /take-off climb surface, that slopes upwards and outwards to the inner horizontal surface or a predetermined height of 45 m (150 ft).

Note. – See Figure 4-3 Transitional Surfaces. See Table 4-1 for dimensions and slopes of surfaces.

4.1.6 ¹⁰ *Characteristics.* The limits of a transitional surface shall comprise:

- a) a lower edge beginning at the intersection of the side of the approach /take-off climb surface with the inner horizontal surface, or beginning at a specified height above the lower edge when an inner horizontal surface is not provided, and extending down the side of the approach /take-off climb surface to the inner edge of the approach /take-off climb surface and from there along the length of the side of the safety area parallel to the centre line of the FATO (or FATO/TLOF); and
- b) an upper edge located in the plane of the inner horizontal surface, or at a specified height above the lower edge when an inner horizontal surface is not provided as set out in Table 4-1.

4.1.7 ¹¹ The elevation of a point on the lower edge shall be:

- a) along the side of the approach surface - equal to the elevation of the approach surface at that point; and
- b) along the safety area - equal to the elevation of the centre line of the FATO (or FATO/TLOF) opposite that point.

Note. - As a result of b) the transitional surface along the safety area will be curved if the profile of the FATO is curved, or a plane if the profile is a straight line. ~~The intersection of the transitional surface with the inner horizontal surface, or upper edge when an inner horizontal surface is not provided, will also be a curved or a straight line depending on the profile of the FATO.~~

4.1.8 **12** The slope of the transitional surface shall be measured in a vertical plane at right angles to the centre line of the FATO (or FATO/TLOF).

Inner horizontal surface

Note.— ~~The intent of the inner horizontal surface is to allow safe visual manoeuvring.~~

~~4.1.9—Description. A circular surface located in a horizontal plane above a FATO and its environs.~~

~~Note.~~— ~~See Figure 4-1~~

~~4.1.10—Characteristics. The radius of the inner horizontal surface shall be measured from the mid-point of the FATO.~~

~~4.1.11—The height of the inner horizontal surface shall be measured above an elevation datum established for such purpose.~~

~~Note.~~— ~~Guidance on determining the elevation datum is contained in the Heliport Manual.~~

Conical surface

~~4.1.12—Description. A surface sloping upwards and outwards from the periphery of the inner horizontal surface, or from the outer limit of the transitional surface if an inner horizontal surface is not provided.~~

~~Note.~~— ~~See Figure 4-1~~

~~4.1.13—Characteristics. The limits of the conical surface shall comprise:~~

- ~~a) a lower edge coincident with the periphery of the inner horizontal surface, or outer limit of the transitional surface if an inner horizontal surface is not provided; and~~
- ~~b) an upper edge located at a specified height above the inner horizontal surface, or above the elevation of the lowest end of the FATO if an inner horizontal surface is not provided.~~

~~4.1.14—The slope of the conical surface shall be measured above the horizontal.~~

Take-off climb surface

4.1.15 **13** *Description.* An inclined plane, a combination of planes or, when a turn is involved, a complex surface sloping upwards from the end of the safety area and centred on a line passing through the centre of the FATO (or FATO/TLOF) (see Figure 4-1). There is an option for heliports intended to be used by helicopters operated in performance class 1 and when approved by an appropriate authority, to raise the origin of the inclined plane directly above the safety area.

Note 1. - See Heliport Manual (Doc 9261) for guidance.

Note 2. - See Figure 4-1, 4-2, 4-3 and 4-4 for depiction of surfaces. See Table 4-1 for dimensions and slopes of surfaces.

4.1.16 **14** *Characteristics.* The limits of a take-off climb surface shall comprise:

- a) an inner edge horizontal and equal in length to the minimum specified width/diameter of the FATO (or FATO/TLOF) plus the safety area, perpendicular to the centre line of the take-off climb surface and located at the outer edge of the safety area or clearway;
- b) two side edges originating at the ends of the inner edge and diverging uniformly at a specified rate from the vertical plane containing the centre line of the FATO (or FATO/TLOF); and
- c) an outer edge horizontal and perpendicular to the centre line of the take-off climb surface and at a specified height of 152 m (500 ft) above the elevation of the FATO (or FATO/TLOF).

4.1.17 **15** The elevation of the inner edge shall be the elevation of the safety area FATO (or FATO/TLOF) at the point on the inner edge that is intersected by the centre line of the take-off climb surface, ~~except that when a clearway is provided, the elevation shall be equal to the highest point on the ground on the centre line of the clearway.~~

4.1.16 Where a clearway is provided the elevation of the inner edge of the take-off climb surface shall be located at the outer edge of the clearway at the highest point on the ground based on the centre line of the clearway.

4.1.18 **17** In the case of a straight take-off climb surface, the slope shall be measured in the vertical plane containing the centre line of the surface.

4.1.19 **18** In the case of a take-off climb surface involving a turn, the surface shall be a complex surface containing the horizontal normal's to its centre line and the slope of the centre line shall be the same as that for a straight take-off climb surface. ~~That portion of the surface between the inner edge and 30 m above the inner edge shall be straight.~~

Note. - See Figure 4-5.

4.1.19 In the case of a take-off climb surface involving a turn, the surface shall not contain more than one curved portion.

4.1.20 Where a curved portion of a take-off climb surface is provided the sum of the radius of arc defining the centre line of the take-off climb surface and the length of the straight portion originating at the inner edge shall not be less than 575 m.

4.1.20 21 Any variation in the direction of the centre line of a take-off climb surface shall be designed so as not to necessitate a turn of radius less than 270 m.

Note 1.— Helicopter take-off performance is reduced in a curve and as such a straight portion along the take-off climb surface prior to the start of the curve allows for acceleration.

Note 2.— For heliports intended to be used by helicopters operated in performance class 2 and 3 helicopters, it is intended that it is good practice for the departure paths should to be selected so as to permit safe forced landings or one-engine-inoperative landings such that, as a minimum requirement, injury to persons on the ground or water or damage to property are minimized. Provisions for forced landing areas are expected to minimize risk of injury to the occupants of the helicopter. The most critical helicopter type for which the heliport is intended and the ambient conditions will may be factors in determining the suitability of such areas.

Rationale

Obstacle Restriction and Removal has been changed to Obstacle Environment to better reflect what the chapter stands for. Most descriptions now reference the FATO for elevation. Wording of performance operations is now consistent with Annex 6, Part 3.

Approach surfaces incorporating turns have been added, as it is just the reverse of the take-off climb surface.

Inner horizontal and conical surfaces have been removed, as they were a carry-over from fixed-wing circling criteria and do not occur in the heliport environment.

Obstacle-free sector/surface — helidecks

4.1.212 *Description.* A complex surface originating at and extending from, a reference point on the edge of the FATO/TLOF of a helideck. In the case of a FATO/TLOF of less than 1 D, the reference point shall be located not less than 0.5D from the centre of the FATO/TLOF.

4.1.223 *Characteristics.* An obstacle-free sector/surface shall subtend an arc of specified angle.

4.1.234 A helideck obstacle-free sector shall comprise of two components, one above and one below helideck level (see Figure 4-2):

Note: See Figure 4-7.

a) Above helideck level: The surface shall be a horizontal plane level with the elevation of the helideck surface that subtends an arc of at least 210 degrees with the apex located on the periphery of the D reference circle extending outwards to a distance that will allow for an unobstructed departure path appropriate to the helicopter the helideck is intended to serve.

b) Below helideck level: Within the (minimum) 210-degree arc, the surface shall additionally extend downward from the edge of the FATO/TLOF below the elevation of the helideck to water level for an arc of not less than 180 degrees that passes through the centre of the FATO/TLOF and outwards to a distance that will allow for safe clearance from the obstacles below the helideck in the event of an engine failure for the type of helicopter the helideck is intended to serve.

Note. For both the above obstacle free sectors for helicopters operated in Performance class 1 or 2 the horizontal extent of these distances from the helideck will be compatible with the one-engine inoperative capability of the helicopter type to be used.

Limited obstacle surface — helidecks

Note. Where obstacles are necessarily located on the structure, a helideck may have a limited obstacle sector.

4.1.245 *Description.* A complex surface originating at the reference point for the obstacle-free sector and extending over the arc not covered by the obstacle-free sector within which the height of obstacles above the level of the FATO/TLOF will be prescribed.

4.1.256 *Characteristics.* A limited obstacle sector shall not subtend an arc greater than 150 degrees. Its dimensions and location shall be as indicated in Figure 4-38 for a 1D FATO/TLOF and Figure 4-9 for a 0.83D FATO/TLOF.

Rationale

On a helideck it is assumed that the FATO and TLOF will always be coincidental. Editorial amendments are now made to cover this combined area referred to throughout the section as “FATO/TLOF”.

A FATO/TLOF for a helicopter with a MTOM of 3175 kg or less may accommodate a circle of diameter less than 1D, but not less than 0.83D (3.3.3b refers). Up until now there has not been a Figure presentation displaying sectors and surfaces for the 0.83D minimum size arrangement and it is considered that this information is very useful, if not essential, for designers of 0.83D helidecks. A scheme showing the sectors and surfaces for a 0.83D FATO/TLOF is presented as Figure 4-9.

4.2 Obstacle limitation requirements

Note 1.- The requirements for obstacle limitation surfaces are specified on the basis of the intended use of a FATO (or FATO/TLOF), i.e. approach manoeuvre to hover or landing, or take-off manoeuvre and type of approach, and are intended to be applied when such use is made of the FATO (or FATO/TLOF). In cases where operations are conducted to or from both directions of a FATO (or FATO/TLOF), then the function of certain surfaces may be nullified because of more stringent requirements of another lower surface.

Note 2.— If a Visual approach slope indicator (VASI) is installed, there are additional obstacle protection surfaces, detailed in Chapter 5, that need to be considered and may be more demanding than the obstacle limitation surfaces prescribed in Table 4 -1.

Surface level heliports

4.2.1 The following obstacle limitation surfaces shall be established for a ~~precision approach FATO~~; a FATO (or FATO/TLOF) at heliports with a PinS approach procedure utilizing a visual segment surface:

- a) take-off climb surface;
- b) approach surface; and
- c) transitional surfaces;
- d) ~~Conical surface.~~

Note 1.- See Figure 4-3 – Transitional Surfaces

Note 2.- Doc 8168, Volume II, Part IV – Helicopters, details further obstacle limitation surface requirements associated with a visual segment surface.

4.2.2 ~~The following obstacle limitation surfaces shall be established for a non-precision approach FATO:~~

- a) ~~take-off climb surface;~~
- b) ~~approach surface;~~
- e) ~~transitional surfaces; and~~
- d) ~~conical surface if an inner horizontal surface is not provided.~~

4.2.3 ~~2~~ The following obstacle limitation surfaces shall be established for a ~~non-instrument~~ FATO (or FATO/TLOF) at heliports, other than specified in 4.2.1, including heliports with a PinS approach procedure where a visual segment surface is not provided:

- a) take-off climb surface; and
- b) approach surface.

4.2.4 ~~**Recommendation.** The following limitation surfaces should be established for a non-precision approach FATO~~

- a) ~~inner horizontal surface; and~~

b) ~~conical surface.~~

Note. — An inner horizontal surface may not be required if a straight in non precision approach is provided at both ends.

4.2.5 ³ The slopes of the obstacle limitation surfaces shall not be greater than, and their other dimensions not less than, those specified in Tables 4-1 to 4-4 and shall be located as shown in Figures 4-1, 4-2 and 4-6. 4-6-2 to and 4-10-5.

4.2.4 For heliports that utilize a 4.5% slope, objects shall be permitted to penetrate the obstacle limitation surface, if the results of an aeronautical study approved by an appropriate authority have reviewed the associated risks and mitigation measures. The identified objects may limit the heliport operation.

Note. — Annex 6, Part 3 provides procedures that may be useful in determining the extent of obstacle penetration.

4.2.6 ⁵ New objects or extensions of existing objects shall not be permitted above any of the surfaces in 4.2.1 to 4.2.4-² above except when, in the opinion of the appropriate authority, the new object or extension would be shielded by an existing immovable object. shielded by an existing immovable object or after an aeronautical study approved by an appropriate authority, determines that the object will not adversely affect the safety or significantly affect the regularity of operations of helicopters.

Note. - Circumstances in which the shielding principle may reasonably be applied are described in the Airport Services Manual, Part 6.

4.2.7 ⁶ **Recommendation.** - Existing objects above any of the surfaces in 4.2.1 to 4.2.4² should, as far as practicable, be removed except when, in the opinion the appropriate authority the object is shielded by an existing immovable object or after an aeronautical study approved by an appropriate authority it is determined determines that the object would will not adversely affect the safety or significantly affect the regularity of operations of helicopters.

Note.- The application of curved approach or take-off climb surfaces as specified in 4.1.19 ⁵ or 4.1.18 may alleviate the problems created by objects infringing these surfaces.

4.2.8 ⁷ A surface level heliport shall have at least two one take-off climb approach and approach take-off climb surface. s separated by not less than 150°. An aeronautical study shall be undertaken by an appropriate authority when only a single approach and take-off climb surface is provided considering as a minimum, the following factors:

- a) the area/terrain over which the flight is being conducted;
- b) the obstacle environment surrounding the heliport;
- c) the performance and operating limitations of helicopters intending to use the heliport; and
- d) the local meteorological conditions including the prevailing winds.

4.2.8 **Recommendation.** - *A surface level heliport should have at least two approach and take-off climb surfaces to avoid downwind conditions, minimize crosswind conditions and permit for a balked landing.*

Note. - See Heliport Manual (Doc 9261) for guidance.

~~4.2.9 **Recommendation.** *The number and orientation of take-off climb and approach surfaces should be such that the usability factor of a heliport is not less than 95 per cent for the helicopters the heliport is intended to serve.*~~

Elevated heliports

~~4.2.10~~ 9 The obstacle limitation requirements surfaces for elevated heliports shall conform to the requirements for surface level heliports specified in 4.2.1 to 4.2.7 6.

~~4.2.11~~ 10 An elevated heliport shall have at least one two take-off climb approach and approach take-off climb surface.s separated by not less than 150°. An aeronautical study shall be undertaken by an appropriate authority when only a single approach and take-off climb surface is provided considering as a minimum, the following factors:

- a) the area/terrain over which the flight is being conducted;
- b) the obstacle environment surrounding the heliport;
- c) the performance and operating limitations of helicopters intending to use the heliport; and
- d) the local meteorological conditions including the prevailing winds.

4.2.11 **Recommendation.** - *An elevated heliport should have at least two approach and take-off climb surfaces to avoid downwind conditions, minimize crosswind conditions and permit for a balked landing.*

Note. - See Heliport Manual (Doc 9261) for guidance.

Rationale

Take-off climb / approach surface slopes have been simplified and have adopted angles that are consistent with world practices and actual helicopter departure or arrival profiles.

Surfaces associated with PinS approach utilizing a visual segment have been added to reflect similar surfaces detailed in PANS-OPS.

All diagrams have been updated to reflect changed (simplified) text.

Helidecks

Note. The following specifications are for helidecks located on a structure and engaged in such activities as mineral exploitation, research, or construction, but excluding heliports on ships.

4.2.12 A helideck shall have an obstacle-free sector.

Note.- A helideck may have a limited obstacle sector (see 4.1.25).

4.2.13 There shall be no fixed obstacles within the obstacle-free sector above the obstacle-free surface.

4.2.14 In the immediate vicinity of the helideck, obstacle protection for helicopters shall be provided below the helideck level. This protection shall extend over an arc of at least 180 degrees with the origin at the centre of the FATO/TLOF, with a descending gradient having a ratio of one unit horizontally to five units vertically from the edges of the FATO/TLOF within the 180-degree sector. This descending gradient may be reduced to a ratio of one unit horizontally to three within the 180° sector for multi-engine helicopters operated in performance class 1 or 2 (see Figure 4-27).

~~4.2.15 Where a mobile obstacle or combination of obstacles within the obstacle free sector is essential for the operation of the installation, the obstacle(s) shall not subtend an arc exceeding 30 degrees, as measured from the centre of the FATO.~~

Note.- Where there is a requirement to position, at sea surface level, one or more offshore support vessel(s) (e.g. a Standby Vessel) essential to the operation of a fixed or floating offshore facility, but located within the proximity of the fixed or floating offshore facility, any offshore support vessel(s) would need to be positioned so as not to compromise the safety of helicopter operations during take-off departure and/or approach to landing.

4.2.16 For a FATO/TLOF of 1D and larger, within the 150-degree limited obstacle surface/sector out to a distance of 0.62D, measured from the centre of the FATO, 0.12D measured from the point of origin of the limited obstacle sector, objects shall not exceed a height of 0.05D 25 cm above the FATO/TLOF. Beyond that arc, out to an over-all distance of 0.83D a further 0.21D measured from the end of the first sector, the limited obstacle surface rises at a rate of one unit vertically for each two units horizontally originating at a height 0.05D above the level of the FATO/TLOF (see Figure 4-38 which illustrates the surfaces/ sectors for a 1D FATO/TLOF).

Editorial Note.— Delete existing Figure 4-8.

Note.- Where the area enclosed by the FATO/TLOF perimeter marking, is a shape other than circular, the extent of the LOS segments are represented as lines parallel to the perimeter of the landing area rather than arcs. Figure 4-8 has been constructed on the assumption that an octagonal helideck arrangement is provided. Further guidance for square (quadrilateral) and circular FATO/TLOF arrangements is given in the Heliport Manual.

4.2.16 For a FATO/TLOF less than 1D, within the 150 degree limited obstacle surface/sector out to a distance of 0.62D and commencing from a distance 0.5D, both measured from the centre of the FATO/TLOF, objects shall not exceed a height of 5 cm above the FATO/TLOF.

Beyond that arc, out to an overall distance of 0.83D from the centre of the FATO/TLOF, the limited obstacle surface rises at a rate of one unit vertically for each two units horizontally originating at a height 0.05D above the level of the FATO/TLOF (see Figure 4-9 which illustrates the surfaces / sectors for a 0.83D FATO/TLOF).

Note.- Where the area enclosed by the FATO/TLOF perimeter marking, is a shape other than circular, the extent of the LOS segments are represented as lines parallel to the perimeter of the FATO/TLOF rather than arcs. Figure 4-9 has been constructed on the assumption that an octagonal helideck arrangement is provided. Further guidance for square (quadrilateral) and circular FATO/TLOF arrangements is given in the Heliport Manual (Doc 9261).

Rationale

In the current section of Volume II, 4.2.15 presents a ‘hard’ Standard for the control of mobile obstacles or combination of obstacles in the OFS, which effectively prohibits the siting of any essential obstacle on the sea surface within a prescribed ‘arc’. The Offshore Sub-group recognised that the Standard was too onerous and open to misinterpretation, being directed towards an installation that may have little control over mobile obstacles, in the proximity of a helideck, at sea surface level. Also the Standard makes no account for the flexibility of helicopters and the options that exist for avoiding over-flight of obstacles that may be located on the sea surface, such as ‘essential’ offshore support vessels. In consequence, the Standard is being downgraded to a more ‘realistic’ Note.

In the current section of Volume II obstacles located close to the edge of a helideck, in the first segment of the limited obstacle sector, are permitted to rise to a height of 0.05D above helideck level. For a typical 22m helicopter, this means allowable infringements in the 1st segment up to a ‘generous’ 1.1m ADL. According to the available global accident data, there have been a number of obstacle strikes, or near misses, involving a helicopter’s main rotor and obstacles legitimately located in the 1st segment of the LOS. To mitigate further obstacle strikes, an initiative is proposed which limits all obstacles in the 1st segment to 25 cm for helidecks of 1D and greater and to 5 cm for helidecks less than 1D. Accepting that the majority of new builds are either hexagonal or octagonal in shape, the two Figures reflecting the sectors and surfaces are based on a common octagonal arrangement with sectors (0.12D plus

0.21D) now measured from the origin of the OFS.

Shipboard heliports

Purpose-built heliports located forward or aft

4.2.17 The specifications in paragraphs 4.2.20 and 4.2.22 shall be applicable for shipboard heliports completed on or after 1 January 2012.

Purpose-built heliports located forward or aft

4.2.18 When helicopter operating areas are provided in the bow or stern of a ship they shall apply the obstacle criteria given in 4.2.12, 4.2.14 and 4.2.16 above for helidecks.

Amidships location – purpose built and non-purpose built

4.2.19 Forward and aft of the minimum 1D FATO/TLOF shall be two symmetrically located sectors, each covering an arc of 150 degrees, with their apexes on the periphery of the FATO/TLOF ~~D-reference circle~~. Within the area enclosed by these two sectors, there shall be no objects rising above the level of the FATO/TLOF, except those aids essential for the safe operation of a helicopter and then only up to a maximum height of 25 cm.

4.2.20 Objects whose function requires them to be located within the FATO/TLOF (such as lighting or nets) shall not exceed a height of 2.5 cm. Such objects ~~may~~ shall only be present if they do not represent a hazard to helicopters.

Note.- Examples of potential hazards include nets or raised fittings on the deck that might induce dynamic rollover for helicopters equipped with skids.

4.2.21 To provide further protection from obstacles fore and aft of the FATO/TLOF, rising surfaces with gradients of one unit vertically to five units horizontally shall extend from the entire length of the edges of the two 150 degree sectors. These surfaces shall extend for a horizontal distance equal to at least 1 D of the largest helicopter the FATO/TLOF is intended to serve and shall not be penetrated by any obstacle (see Figure 4-910).

Non-purpose built heliports

Ship's side location

4.2.22 No objects shall be located within the FATO/TLOF except those aids essential for the safe operation of a helicopter (such as nets or lighting) and then only up to a maximum height of 2.5cm. Such objects shall only be present if they do not represent a hazard to helicopters.

4.2.23 From the fore and aft mid-points of the ~~D reference~~ circle in two segments outside the circle, ~~an~~ limited obstacle areas shall extend to the ship's rail to a fore and aft distance of 1.5 times the diameter of the FATO/TLOF, located symmetrically about the athwartships bisector of the ~~reference-D~~ circle. Within

~~this these areas sector~~ there shall be no objects rising above a maximum height of 25cm above the level of the FATO/TLOF, ~~except those aids essential to the safe operation of the helicopter and then only up to a maximum height of 25 cm~~ (see Figure 4-101). Such objects shall only be present if they do not represent a hazard to helicopters.

4.2.24 A limited obstacle sector horizontal surface shall be provided, at least 0.25 D times beyond the diameter of the D reference circle, which shall surround the inboard sides of the FATO/TLOF to the fore and aft mid-points of the D circle. The limited obstacle sector shall continue to the ship's rail to a fore and aft distance of 2.0 times the diameter of the FATO/TLOF, located symmetrically about the athwart ships bisector of the D circle. Within this sector there shall be no objects rising above a maximum height of 25cm above the level of the FATO/TLOF ~~and the obstacle free sector at a height of 0.05 times the diameter of the reference circle, which no object shall penetrate.~~

Note. Any objects located within the areas described in 4.2.23 and 4.2.24 that exceed the height of the FATO/TLOF are notified to the helicopter operator using a ship's helicopter landing area plan. For notification purposes it may be necessary to consider immovable objects beyond the limit of the surface prescribed in 4.2.24 particularly if objects are significantly higher than 25 cm and in close proximity to the boundary of the Limited Obstacle Sector. See Heliport Manual (Doc 9261) for guidance.

Winching areas

4.2.25 An area designated for winching on-board ships shall be comprised of a circular clear zone of diameter 5m and extending from the perimeter of the clear zone, a concentric manoeuvring zone of diameter 2D. (See Figure 4-112)

4.2.26 The manoeuvring zone shall be comprised of 2 areas:

- a) The inner manoeuvring zone extending from the perimeter of the clear zone and of a circle of diameter not less than 1.5D; and
- b) The outer manoeuvring zone extending from the perimeter of the inner manoeuvring zone and of a circle of diameter of not less than 2D.

4.2.27 Within the clear zone of a designated winching area, no objects shall be located above the level of its surface.

4.2.28 Objects located within the inner manoeuvring zone of a designated winching area shall not exceed a height of 3m.

4.2.29 Objects located within the outer manoeuvring zone of a designated winching area shall not exceed a height of 6m.

Note. - See Heliport Manual (Doc 9261) for guidance.

Rationale

On a shipboard heliport it is assumed that the FATO and TLOF will always be coincidental. Editorial amendments are now made to cover this combined area referred to throughout the section as “FATO/TLOF”.

For non purpose built heliports located on a ship’s side, the obstacle limitation surfaces are being extensively revised to ensure that the requirements are consistent with the corresponding (new) SARPS for helidecks (see rationale 14), maintaining appropriate levels of safety while reflecting the real life situation with a non-purpose built landing area, provided within the superstructure of a ship. A system for recording and mapping objects in the vicinity of the FATO/TLOF is introduced in a Note.

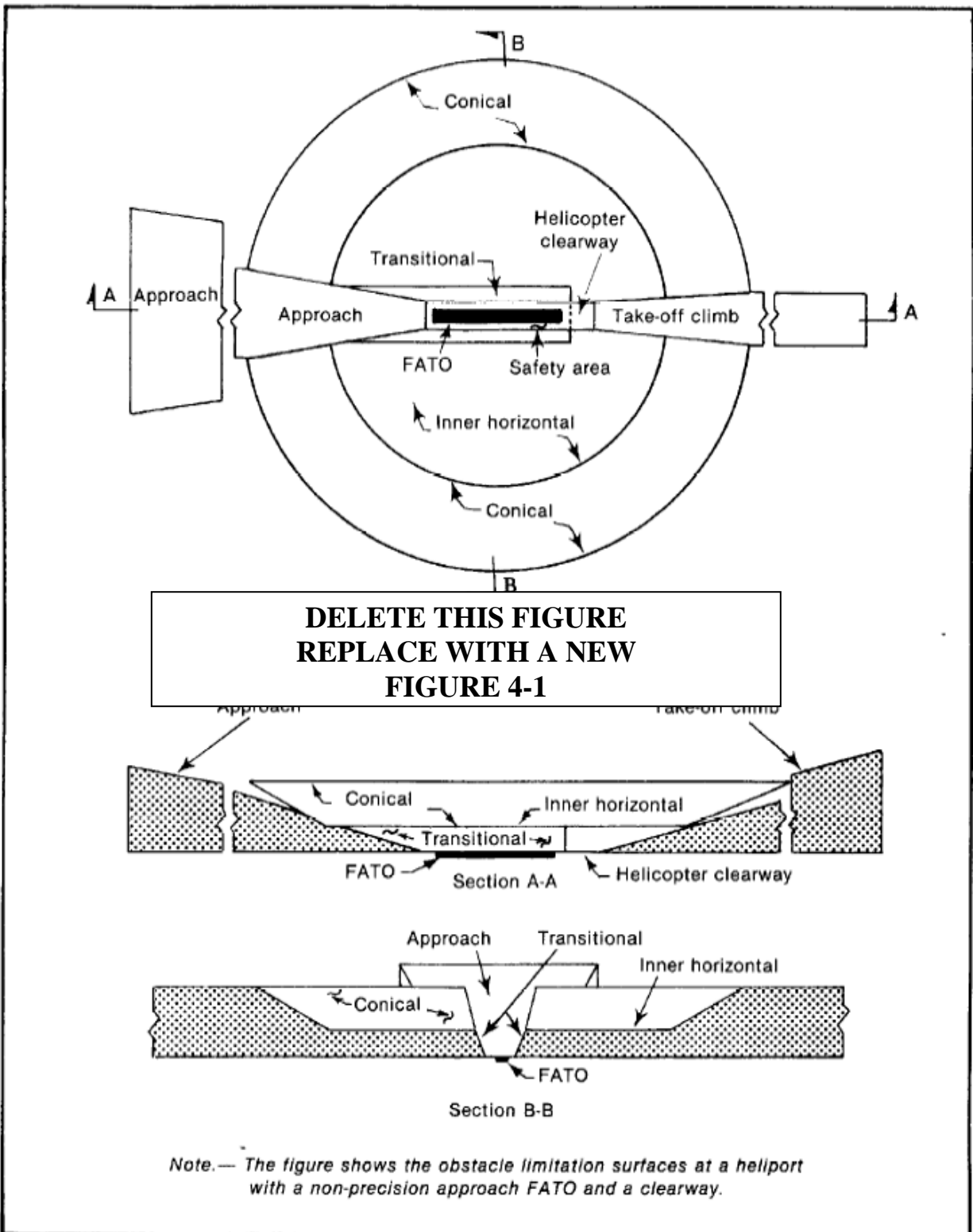

Figure 4-1. Obstacle limitation surfaces

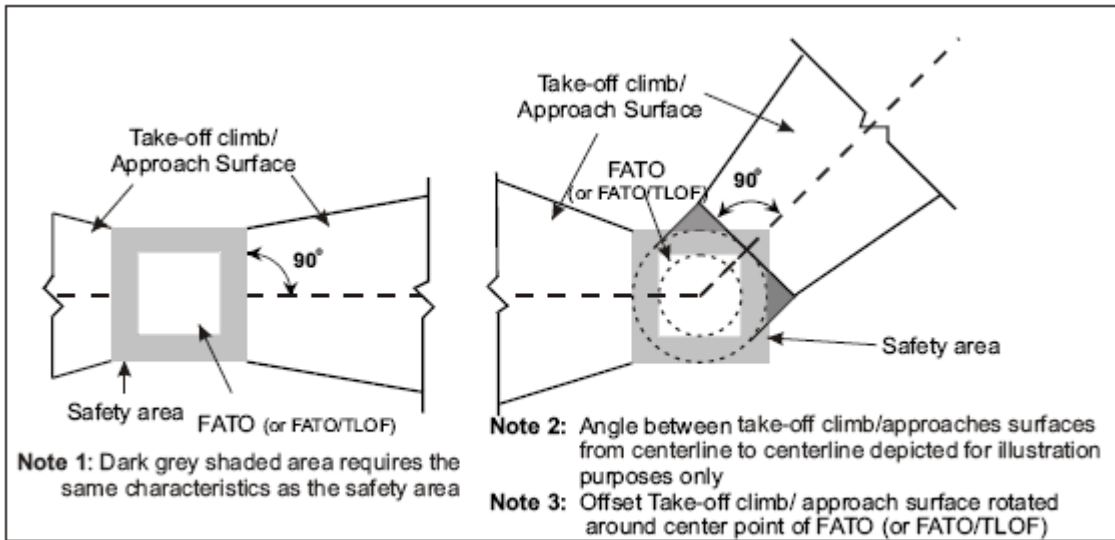

Figure 4-1. Obstacle Limitation Surfaces - Take-off Climb & Approach Surface

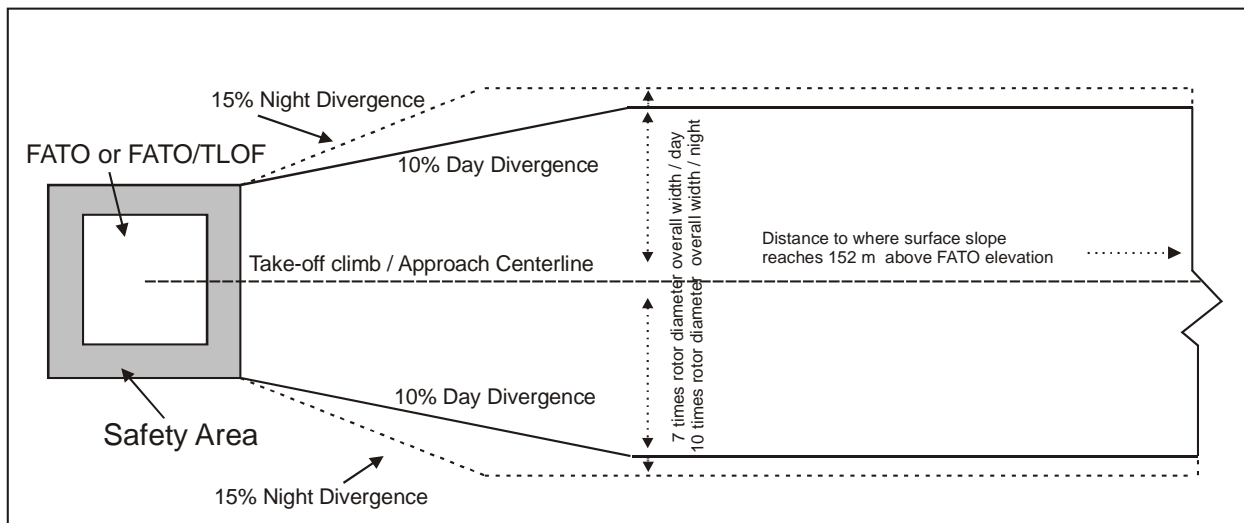

Figure 4-2 Take-off Climb / Approach Surface Width

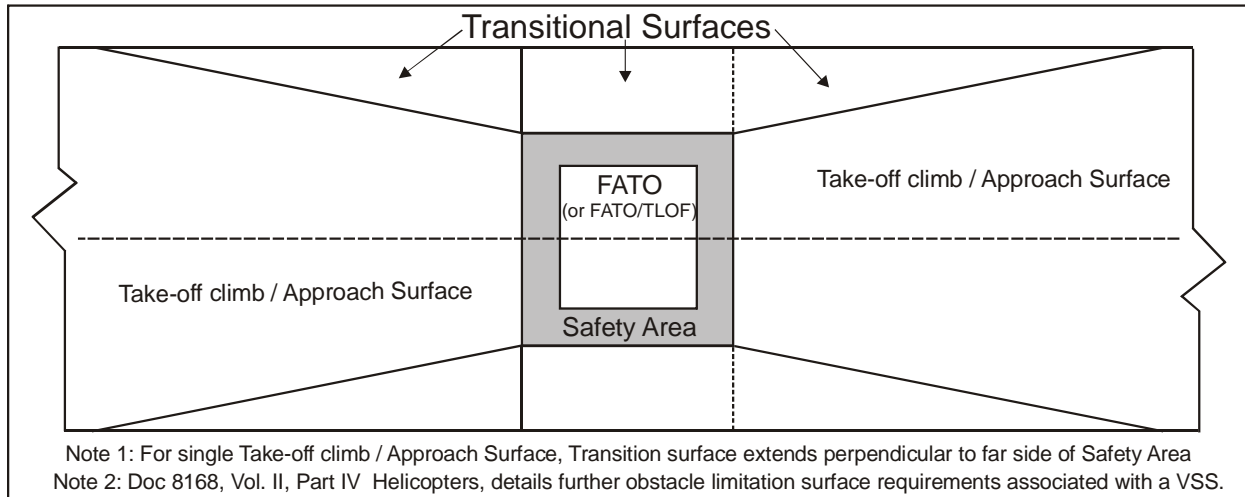

Figure 4-3 Transitional Surfaces for a FATO with a PinS approach procedure with a VSS

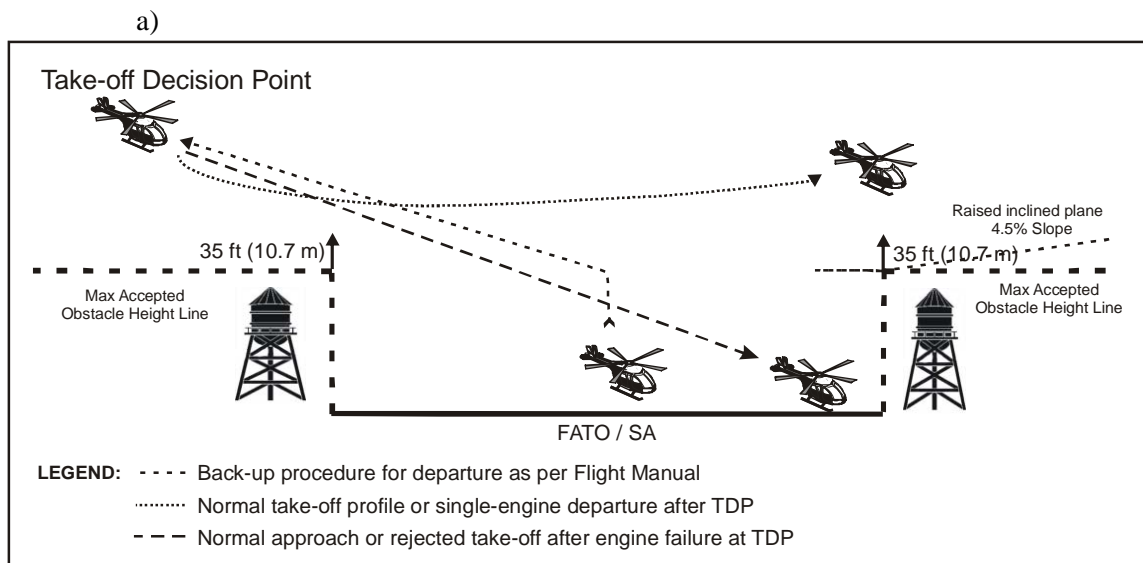

Figure 4-4 Example of Raised Inclined Plane During Operations in Performance Class 1

Note 1.- This example diagram does not represent any specific profile, technique or helicopter type and is intended to show a generic example. An approach profile and a back-up procedure for departure profile are depicted. Specific manufacturers operations in performance class 1 may be represented differently in the specific Helicopter Flight Manual. Annex 6, Part 3, Attachment A provides back-up procedures that may be useful for operations in performance class 1.

Note 2.- The approach / landing profile may not be the reverse of the take-off profile.

Note 3.— Additional obstacle assessment might be required in the area that a back-up procedure is intended. Helicopter performance and the Helicopter Flight Manual limitations will determine the extent of the assessment required.

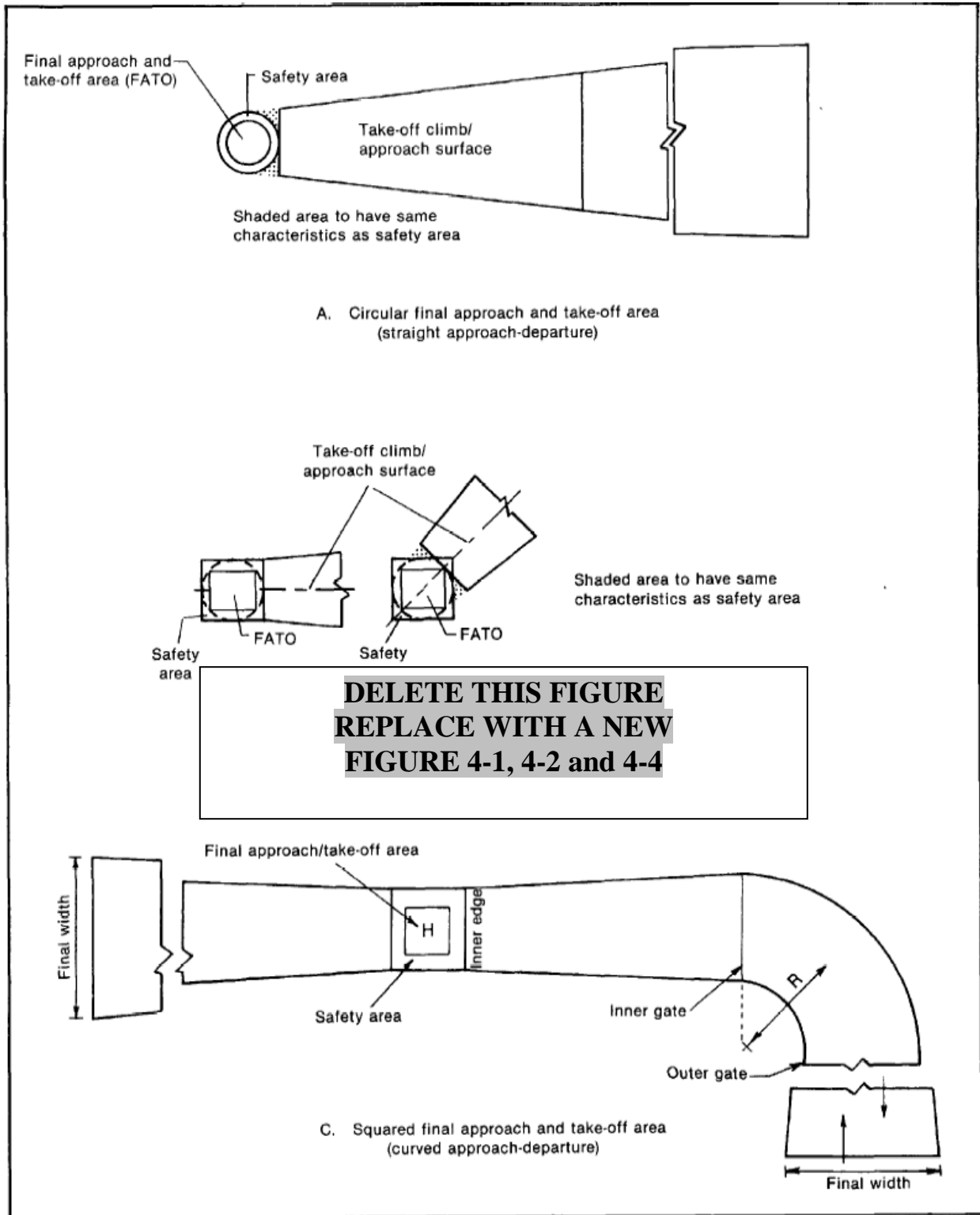

Figure 4-6. Take-off climb/approach surface (non-instrument FATO)

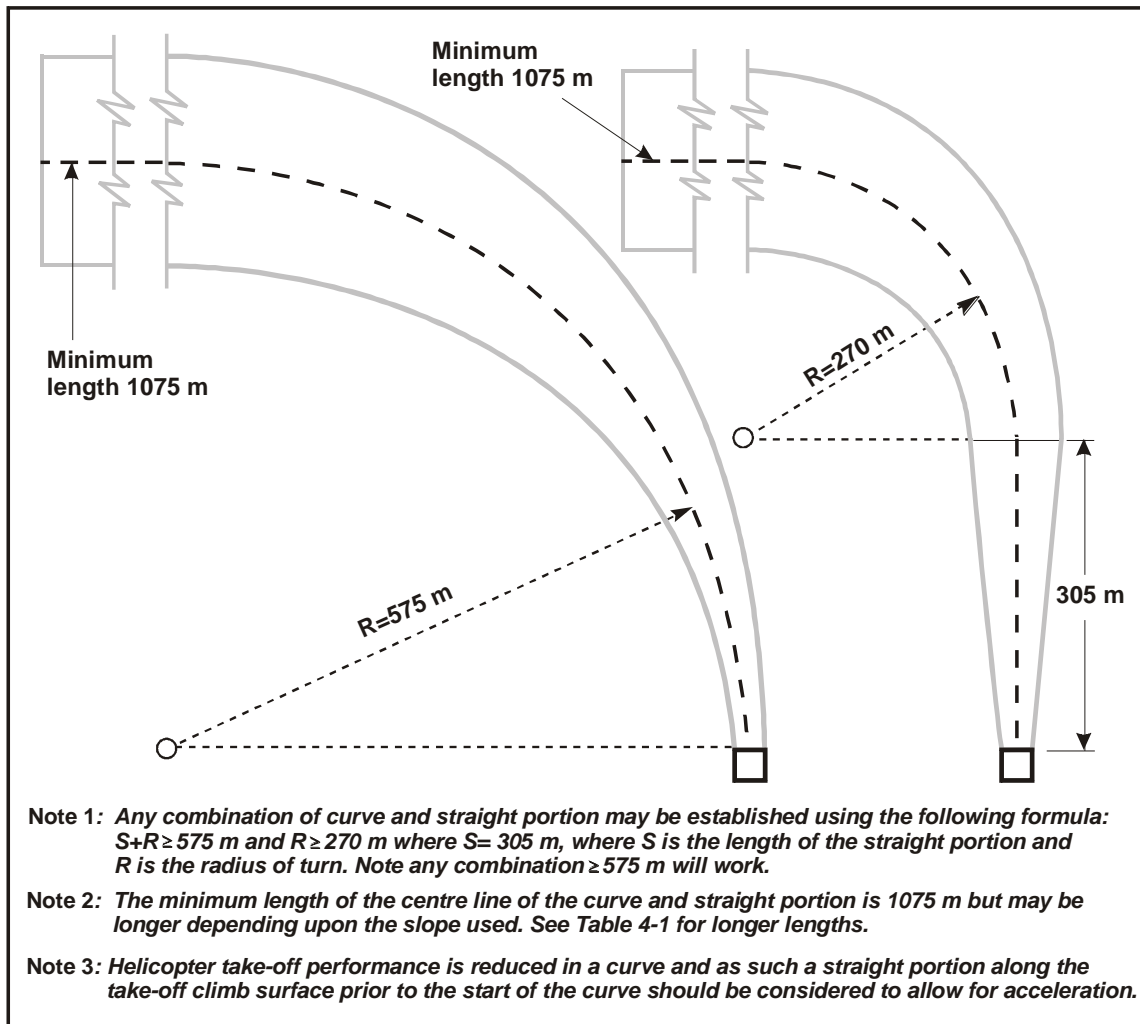
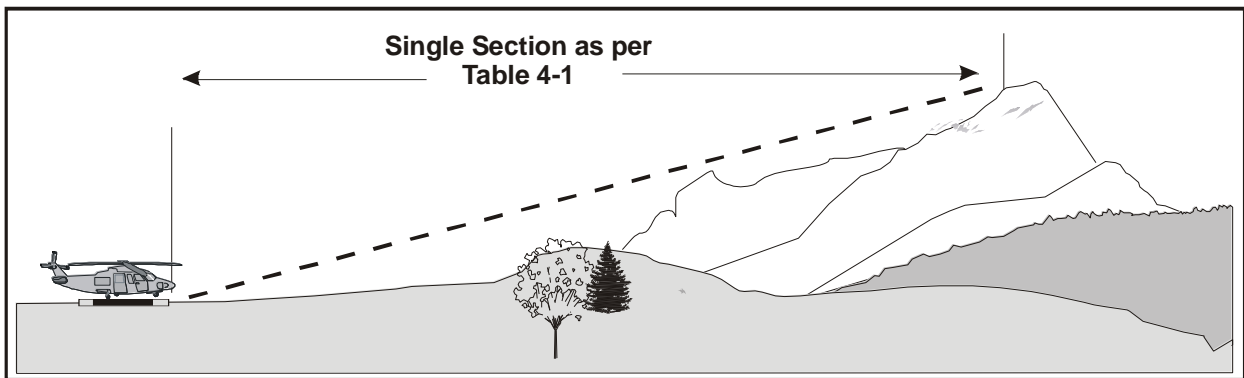
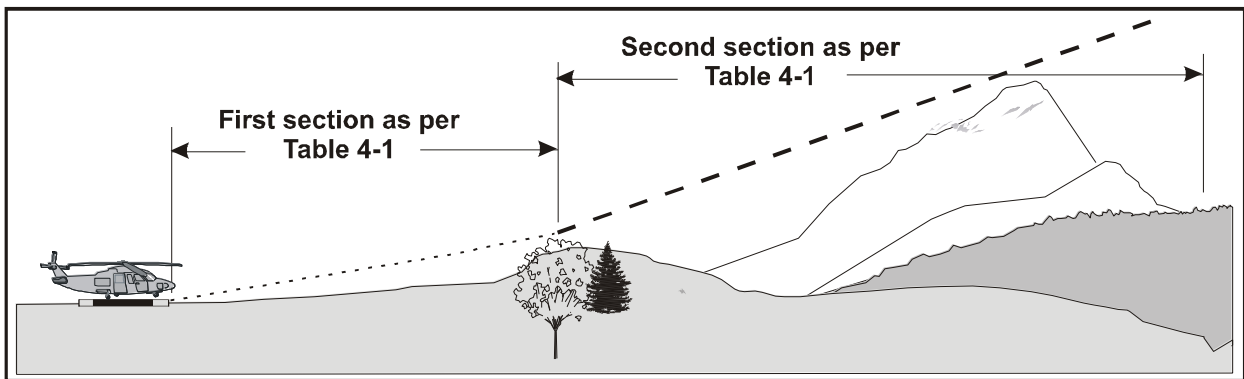
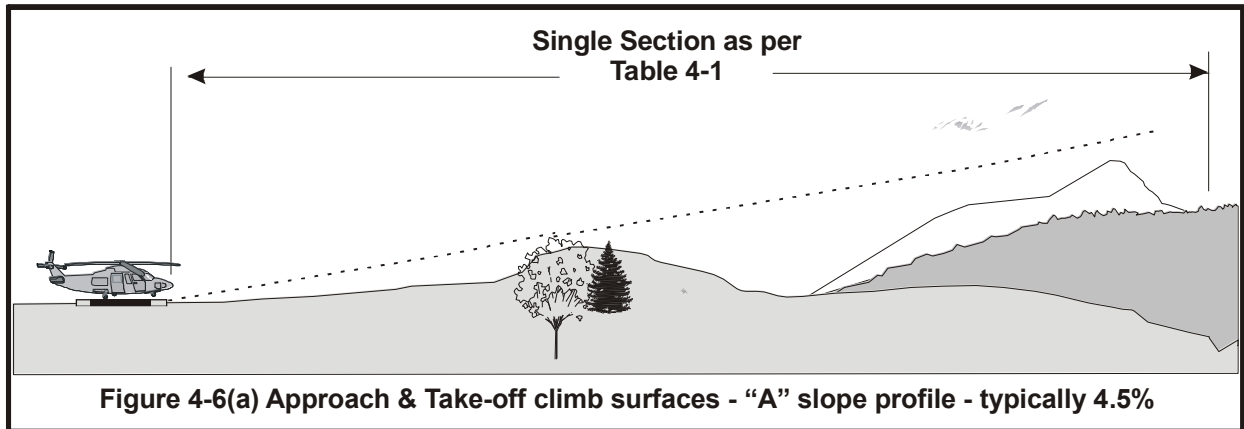

Figure 4-5. Curved approach and take-off climb surface for all FATOs including FATO/TLOFs

Editorial Note.— Existing Figure 4-5 relocated to Appendix 2, Figure A4-1.

Editorial Note.— Existing Figure 4-6 relocated to Appendix 2, Figure A4-2.

Editorial Note.— Existing Figure 4-7 relocated to Appendix 2, Figure A4-3.



Editorial Note.— Relevant data from Tables 4-1, 4-3 and 4-4 combined into new Table 4-1.

Editorial Note.— Table 4-2 moved in its entirety to Table A4-2 in Appendix 2.

Editorial Note.— Relevant data from existing Table 4-1 also used to create new Table A4-1 in Appendix 2.

Editorial Note.— Relevant data from existing Table 4-3 also used to create new Table A4-3 in Appendix 2.

Table 4-1. Dimensions and slopes of obstacle limitation surfaces

NON-INSTRUMENT AND NON-PRECISION FATO

Surface and dimensions		Non-instrument (visual) FATO			Non-precision (instrument approach) FATO
		Helicopter performance class			
		1	2	3	
APPROACH SURFACE					
Width of inner edge		Width of safety area			Width of safety area
Location of inner edge		Boundary			Boundary
<i>First section</i>					
Divergence	— day	10%	10%	10%	16%
	— night	15%	15%	15%	
Length	— day	245 m ^a	245 m ^a	245 m ^a	2 500 m
	— night	245 m ^a	245 m ^a	245 m ^a	
Outer width	— day	49 m ^b	49 m ^b	49 m ^b	890 m
	— night	73.5 m ^b	73.5 m ^b	73.5 m ^b	
Slope (maximum)		8% ^a	8% ^a	8% ^a	3.33%
<i>Second section</i>					
Divergence	— day	10%	10%	10%	—
	— night	15%	15%	15%	
Length	— day	c	c	c	—
	— night	c	c	c	
Outer width	— day	d	d	d	—
	— night	d	d	d	
Slope (maximum)		12.5%	12.5%	12.5%	—
<i>Third section</i>					
Divergence		parallel	parallel	parallel	—
Length	— day	e	e	e	—
	— night	e	e	e	
Outer width	— day	d	d	d	—
	— night	d	d	d	
Slope (maximum)		15%	15%	15%	—
INNER HORIZONTAL					
Height		—	—	—	45 m
Radius		—	—	—	2 000 m
CONICAL					
Slope		—	—	—	5%
Height		—	—	—	55 m
TRANSITIONAL					
Slope		—	—	—	20%
Height		—	—	—	45 m

a. Slope and length enables helicopters to decelerate for landing while observing "avoid" areas.

b. The width of the inner edge shall be added to this dimension.

c. Determined by the distance from the inner edge to the point where the divergence produces a width of 7 rotor diameters for day operations or 10 rotor diameters for night operations.

d. Seven rotor diameters over-all width for day operations or 10 rotor diameters over-all width for night operations.

e. Determined by the distance from inner edge to where the approach surface reaches a height of 150 m above the elevation of the inner edge.

Table 4-3. Dimensions and slopes of obstacle limitation surfaces

Surface and dimensions		Non-instrument (visual)			Instrument
		Helicopter performance class			
		1	2	3	
STRAIGHT TAKE-OFF					
TAKE-OFF CLIMB					
Width of inner edge Location of inner edge		Width of safety area Boundary or end of clearway			90 m Boundary or end of clearway
<i>First section</i>					
Divergence	— day	10%	10%	10%	30%
	— night	15%	15%	15%	
Length	— day	a	245 m ^b	245 m ^b	2 850 m
	— night	a	245 m ^b	245 m ^b	
Outer width	— day	c	49 m ^d	49 m ^d	1 800 m
	— night	c	73.5 m ^d	73.5 m ^d	
Slope (maximum)		4.5%*	8% ^b	8% ^b	3.5%
<i>Second section</i>					
Divergence	— day	parallel	10%	10%	parallel
	— night	parallel	15%	15%	
Length	— day	e	a	a	1 510 m
	— night	e	a	a	
Outer width	— day	c	c	c	1 800 m
	— night	c	c	c	
Slope (maximum)		4.5%*	15%	15%	3.5%*
<i>Third section</i>					
Divergence		—	parallel	parallel	parallel
Length	— day	—	e	e	7 640 m
	— night	—	e	e	
Outer width	— day	—	c	c	1 800 m
	— night	—	c	c	
Slope (maximum)		—	15%	15%	2%
<p>a. Determined by the distance from the inner edge to the point where the divergence produces a width of 7 rotor diameters for day operations or 10 rotor diameters for night operations.</p> <p>b. Slope and length provides helicopters with an area to accelerate and climb while observing "avoid" areas.</p> <p>c. Seven rotor diameters over-all width for day operations or 10 rotor diameters over-all width for night operations.</p> <p>d. The width of the inner edge shall be added to this dimension.</p> <p>e. Determined by the distance from the inner edge to where the surface reaches a height of 150 m above the elevation of the inner edge.</p>					
* This slope exceeds the maximum mass one-engine-inoperative climb gradient of many helicopters which are currently operating.					

Table 4-4. Criteria for curved take-off climb/approach area
NON-INSTRUMENT FINAL APPROACH AND TAKE-OFF

Facility	Requirement
Directional change	As required (120° max).
Radius of turn on centre line	Not less than 270 m.
Distance to inner gate*	(a) For performance class 1 helicopters — not less than 305 m from the end of the safety area or helicopter clearway. (b) For performance class 2 and 3 helicopters — not less than 370 m from the end of the FATO.
Width of inner gate — day	Width of the inner edge plus 20% of distance to inner gate.
— night	Width of the inner edge plus 30% of distance to inner gate.
Width of outer gate — day	Width of inner edge plus 20% of distance to inner gate out to minimum width of 7 rotor diameters.
— night	Width of inner edge plus 30% of distance to inner gate out to a minimum width of 10 rotor diameters.
Elevation of inner and outer gates	Determined by the distance from the inner edge and the designated gradient(s).
Slopes	As given in Tables 4-1 and 4-3.
Divergence	As given in Tables 4-1 and 4-3.
Total length of area	As given in Tables 4-1 and 4-3.

* This is the minimum distance required prior to initiating a turn after take-off or completing a turn in the final phase.

Note.— More than one turn may be necessary in the total length of the take-off climb/approach area. The same criteria will apply for each subsequent turn except that the widths of the inner and outer gates will normally be the maximum width of the area.

TABLE 4-1
Dimensions and slopes of obstacle limitation surfaces
For All Visual FATOs including FATO/TLOFs

TABLE 4-1			
Dimensions and slopes of obstacle limitation surfaces			
For All Visual FATOs including FATO/TLOFs			
	SLOPE CATEGORIES		
	A	B	C
SURFACE and DIMENSIONS			
APPROACH and TAKE-OFF CLIMB SURFACE:			
Length of inner edge	Width of safety area	Width of safety area	Width of safety area
Location of inner edge	Safety area boundary (Clearway boundary if provided)	Safety area boundary	Safety area boundary
Divergence: (1st & 2nd section)			
Day use only	10%	10%	10%
Night use	15%	15%	15%
First Section:			
Length	(a)	245 m	1220 m
Slope	4.5% (1:22.2)	8% (1:12.5)	12.5% (1:8)
Outer Width	(c)	N/A	(c)
Second Section:			
Length	N/A	830 m	N/A
Slope	N/A	16% (1:6.25)	N/A
Outer Width	N/A	(c)	N/A
Total Length from inner edge (b)	(a)	1075 m	1220 m
Transitional Surface: (FATOs including FATO/TLOFs with a PinS approach procedure with a VSS)			
Slope	50% (1:2)	50% (1:2)	50% (1:2)
Height	45 m	45 m	45 m

(a) Determined by the distance from the inner edge to where the surface reaches a height of 152 m above the elevation of the inner edge. On level ground, this would typically be 3386 m (2.1 SM) in length.

- (b) The approach and take-off climb surface lengths of 3386 m, 1075 m and 1220 m associated with the respective slopes, brings the helicopter to 152 m (500 ft) above FATO (or FATO/TLOF) elevation. This is typically the transition elevation between non-instrument and instrument flight.
- (c) Seven rotor diameters overall width for day operations or 10 rotor diameters overall width for night operations.

Note.— The slope categories in Table 4-1 may not be restricted to a specific performance class of operation and may be applicable to more than one performance class of operation. The slope categories depicted in Table 4-1 represent minimum design slope angles and not operational slopes. Slope category “A” generally corresponds with helicopters operated in performance class 1; slope category “B” generally corresponds with helicopters operated in performance class 3; and slope category “C” generally corresponds with helicopters operated in performance class 2. Consultation with helicopter operators will help to determine the appropriate slope category to apply according to the heliport environment and the most critical helicopter type for which the heliport is intended.

Editorial Note. Renumber Figure 4-2 to Figure 4-7

Figure 4-27. Helideck obstacle-free sector

Editorial Note. Delete existing Figure 4-3. Add new Figure 4-8. Helideck obstacle limitation sectors and surfaces for a 1D FATO/TLOF.

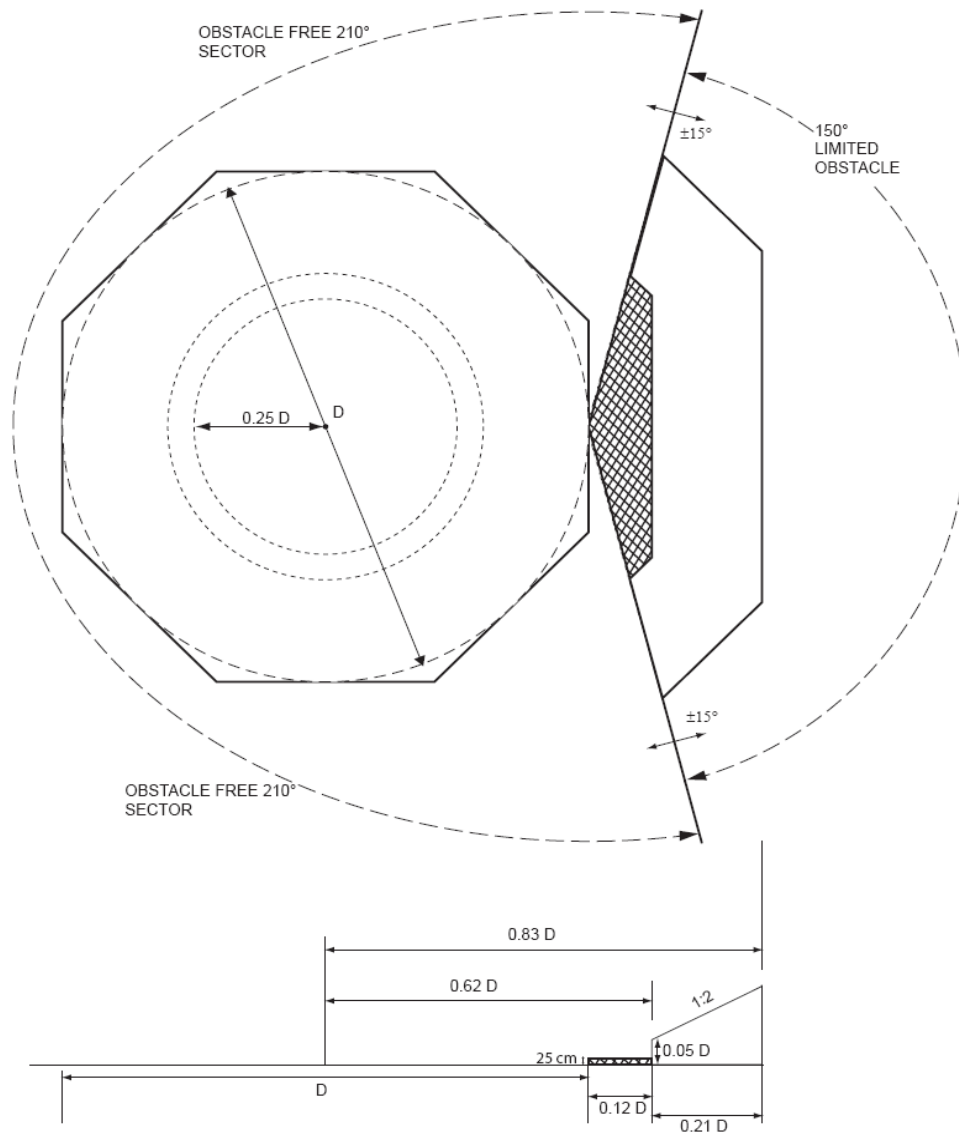

Figure 4-8. Helideck obstacle limitation sectors and surfaces for a 1D FATO/TLOF

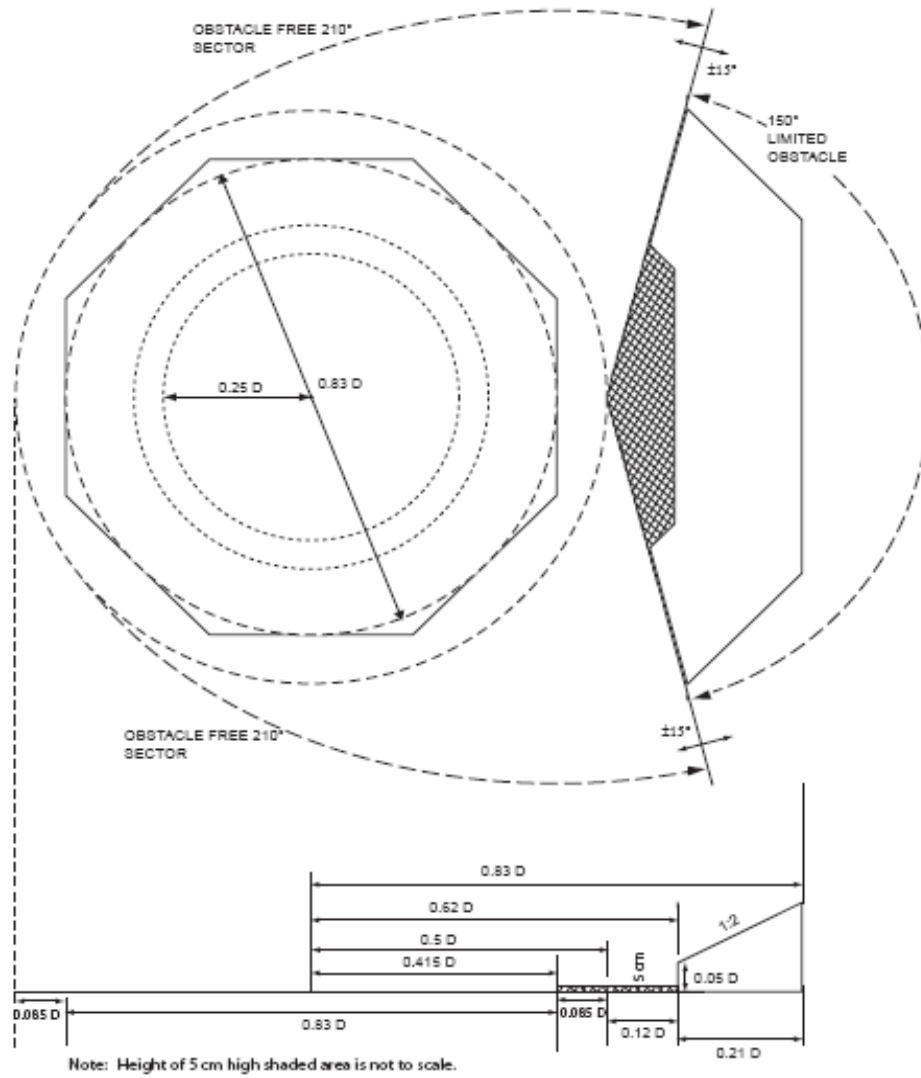

Figure 4-9. Helideck obstacle limitation sectors and surfaces for a 0.83D FATO/TLOF

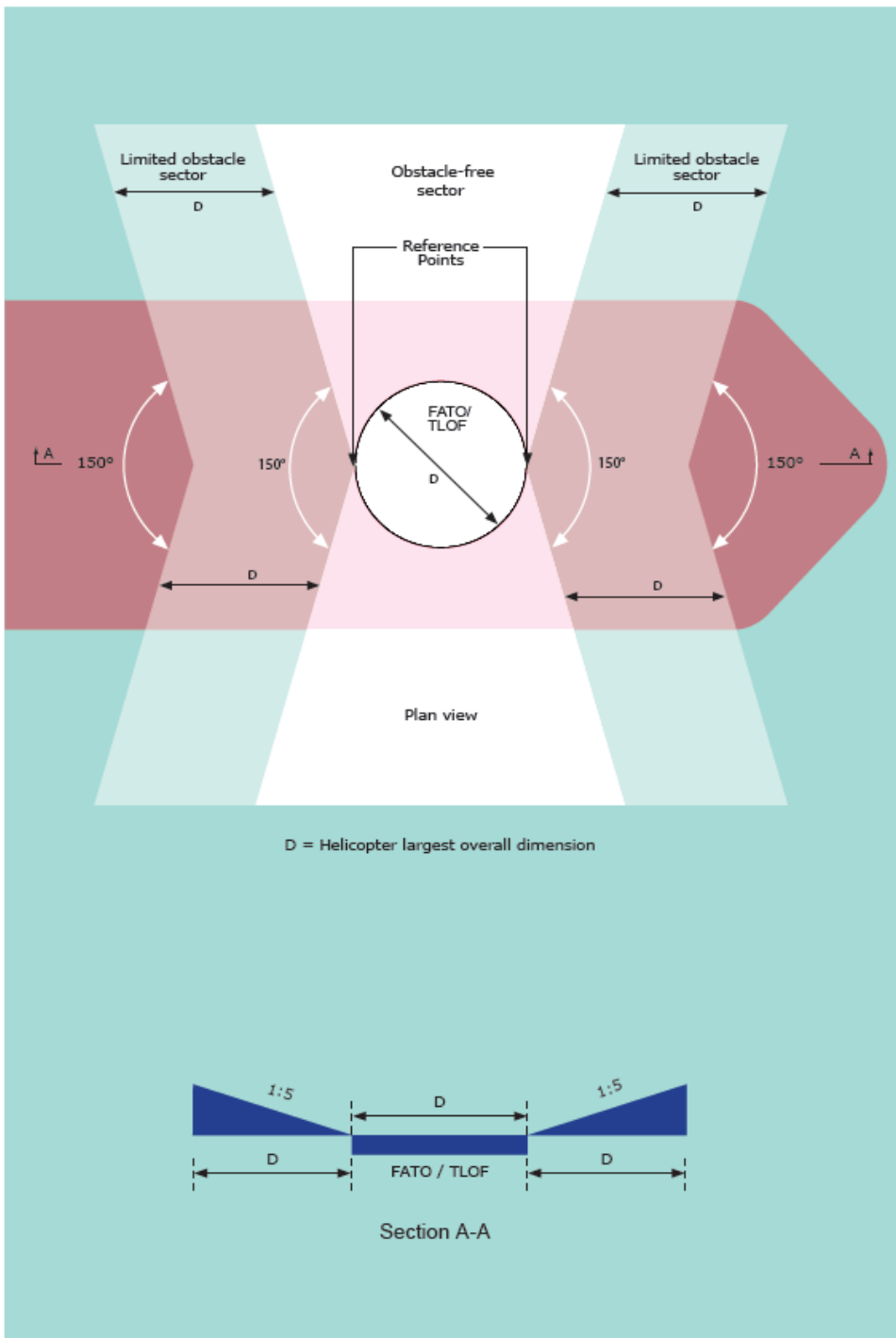

Figure 4-11 Amidships Location - Shipboard Heliport Obstacle Limitation Surfaces

Editorial Note. Figure 4-910. Amidships Location – Shipboard Heliport Obstacle Limitation Surfaces

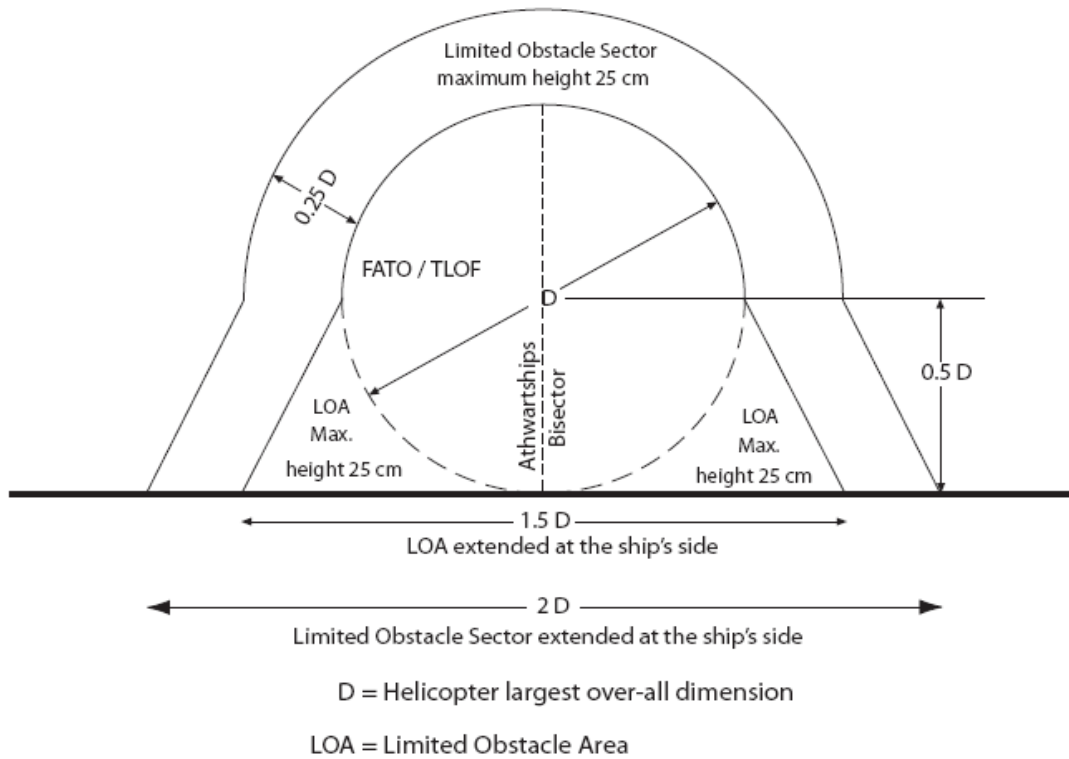

Figure 4.12A Non-Purpose-Built Landing Area: Ship's Side Location -
Obstacle Limitation Surfaces

Editorial Note. Figure 4-1011. Ships-side non-purpose built heliport obstacle limitation sectors and surfaces

Editorial Note.— Retain Figure 4-11 as Figure 4-12.

CHAPTER 5. VISUAL AIDS

Note 1.— The procedures used by some helicopters require that they utilise a FATO having characteristics similar in shape to a runway for fixed wing aircraft. For the purpose of this chapter a FATO having characteristics similar in shape to a runway is considered as satisfying the concept for a "runway-type FATO". For such arrangements it is sometimes necessary to provide specific markings to enable a pilot to distinguish a runway-type FATO during an approach. Appropriate markings are contained within sub-sections entitled "Runway-type FATOs". The requirements applicable to all other types of FATOs are given within sub-sections entitled "All FATOs except runway-type FATOs" and, where indicated, include the requirements for FATO/TLOFs.

Note 2.— It has been found that, on surfaces of light colour, the conspicuity of white and yellow markings can be improved by outlining them in black.

Note 3.— Guidance is given in the Heliport Manual (doc. 9261) on marking the maximum allowable mass (5.2.3), the D-value (5.2.4) and, if required, the actual FATO Dimension(s) (5.2.5) on the heliport surface to avoid confusion between markings where metric units are used and markings where imperial units are used.

Note 4.— For a non-purpose built heliport located on a ship's side the surface colour of the main deck can vary from ship to ship and therefore some discretion may need to be exercised in the colour selection of heliport paint schemes; the objective being to ensure that the markings are conspicuous against the surface of the ship and the operating background.

5.1 Indicators

5.1.1 Wind direction indicators

Application

5.1.1.1 A heliport shall be equipped with at least one wind direction indicator.

Location

5.1.1.2 A wind direction indicator shall be located so as to indicate the wind conditions over the FATO or FATO/TLOF and in such a way as to be free from the effects of airflow disturbances caused by nearby objects or rotor downwash. It shall be visible from a helicopter in flight, in a hover or on the movement area.

5.1.1.3 **Recommendation.**— *Where a TLOF or FATO/TLOF may be subject to a disturbed airflow, then additional wind direction indicators located close to the area should be provided to indicate the surface wind on the area.*

Note.— Guidance on the location of wind direction indicators is given in the Heliport Manual (Doc 9261).

Characteristics

5.1.1.4 A wind direction indicator shall be constructed so that it gives a clear indication of the direction of the wind and a general indication of the wind speed.

5.1.1.5 **Recommendation.**— *An indicator should be a truncated cone made of lightweight fabric and should have the following minimum dimensions:*

	Surface level heliports	Elevated heliports and helidecks
<i>Length</i>	<i>2.4 m</i>	<i>1.2 m</i>
<i>Diameter (larger end)</i>	<i>0.6 m</i>	<i>0.3 m</i>
<i>Diameter (smaller end)</i>	<i>0.3 m</i>	<i>0.15 m</i>

5.1.1.6 **Recommendation.**— *The colour of the wind direction indicator should be so selected as to make it clearly visible and understandable from a height of at least 200 m (650 ft) above the heliport, having regard to background. Where practicable, a single colour, preferably white or orange, should be used. Where a combination of two colours is required to give adequate conspicuity against changing backgrounds, they should preferably be orange and white, red and white, or black and white, and should be arranged in five alternate bands the first and last band being the darker colour.*

5.1.1.7 A wind direction indicator at a heliport intended for use at night shall be illuminated.

5.2 Markings and markers

Note.— See Annex 14 Volume I, 5.2.1.4, Note 1 concerning improving conspicuity of markings

5.2.1 Winching area marking

Application

5.2.1.1 Winching area markings shall be provided at a designated winching area (see Figure 4-14~~2~~).

Location

5.2.1.2 Winching area markings shall be located so that the centre(s) coincides with the centre of the clear zone of the winching area (see Figure 4-12).

Characteristics

5.2.1.3 Winching area markings shall comprise a winching area clear zone marking and a winching area manoeuvring zone marking.

5.2.1.4 A winching area clear zone marking shall consist of a solid circle of diameter not less than 5 m in diameter and of a conspicuous colour.

5.2.1.5 A winching area manoeuvring zone marking shall consist of a broken circle of line of 0.2m 30 cm in width and of a diameter not less than 2 D and be marked in a conspicuous colour. Within it “WINCH ONLY” shall be marked to be easily visible to the pilot.

5.2.2 Heliport identification marking

Application

5.2.2.1 A heliport identification markings shall be provided at a heliport.

Location - All FATOs except runway-type FATOs

5.2.2.2 A heliport identification marking shall be located within the FATO, at or near the centre of the area or, when used in conjunction with runway designation markings at each end of the area FATO or FATO/TLOF.

Note 1.- If the Touchdown/positioning marking is offset on a helideck, the heliport identification marking is established in the centre of the Touchdown/positioning marking.

Note 2.- On a FATO, which does not contain a TLOF and which is marked with an aiming point marking (see 5.2.8), except for a heliport at a hospital, the heliport identification marking is established in the centre of the aiming point marking as shown in Figure 5-1.

5.2.2.3 On a FATO which contains a TLOF, a heliport identification marking shall be located in the FATO so the position of it coincides with the centre of the TLOF.

Editorial Note.— Replace figure 5-1 with new Figure 5-1 as follows:

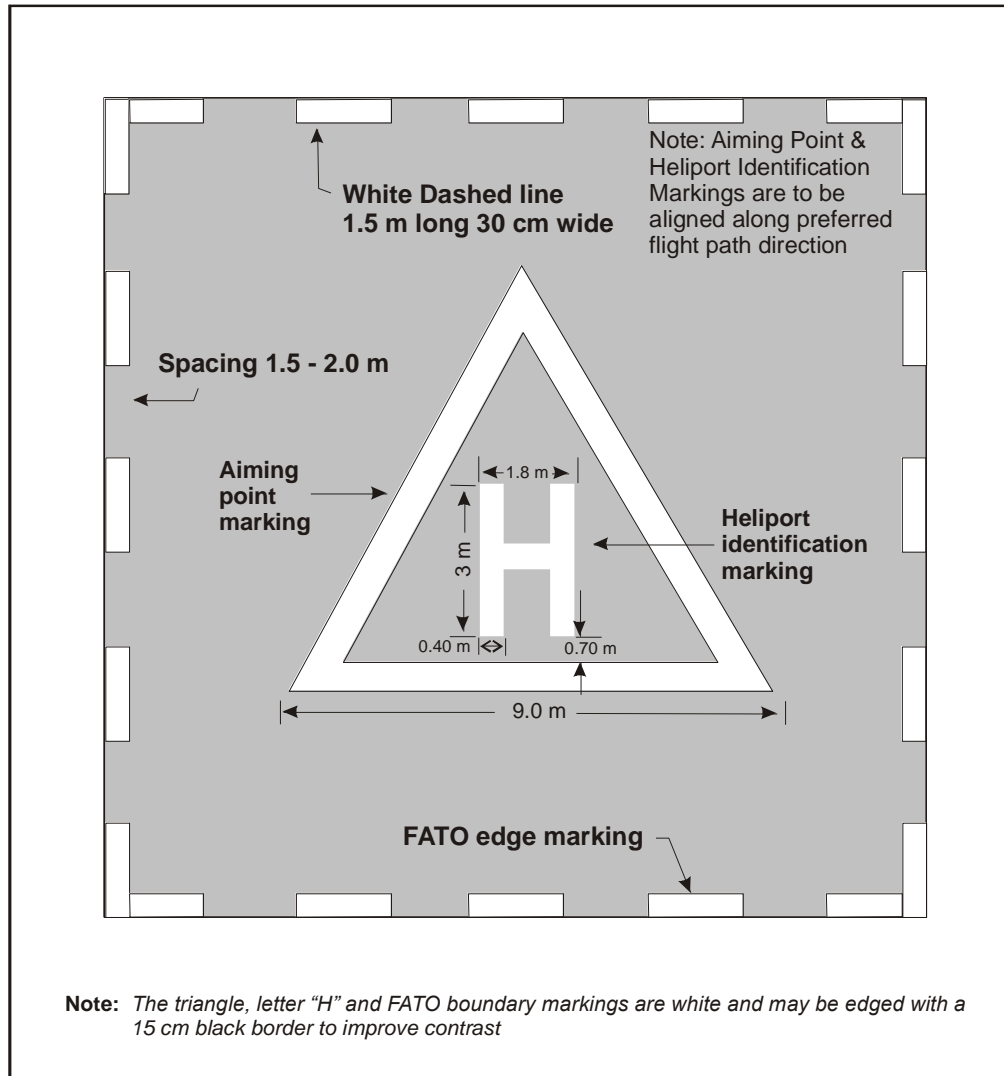

Figure 5-1. Combined heliport identification and aiming point marking

Location - Runway-type FATOs

5.2.2.4 A heliport identification marking shall be located in the FATO and when used in conjunction with FATO designation markings, shall be displayed at each end of the FATO as shown in Figure 5-3.

Characteristics

5.2.2.35 A heliport identification marking, except for a heliport at a hospital, shall consist of a letter H, white in colour. The dimensions of the H marking shall be no less than those shown in Figure 5-12 and where the marking is used for a runway-type FATO in conjunction with the FATO designation marking specified in 5.2.6, its dimensions shall be increased by a factor of 3 as shown in Figure 5-3.

5.2.2.46 A heliport identification marking for a heliport at a hospital shall consist of a letter H, red in colour, on a white cross made of squares adjacent to each of the sides of a square containing the H as shown in Figure 5-2.

Editorial Note.— Replace Figure 5-2 with new Figure 5-2 as follows:

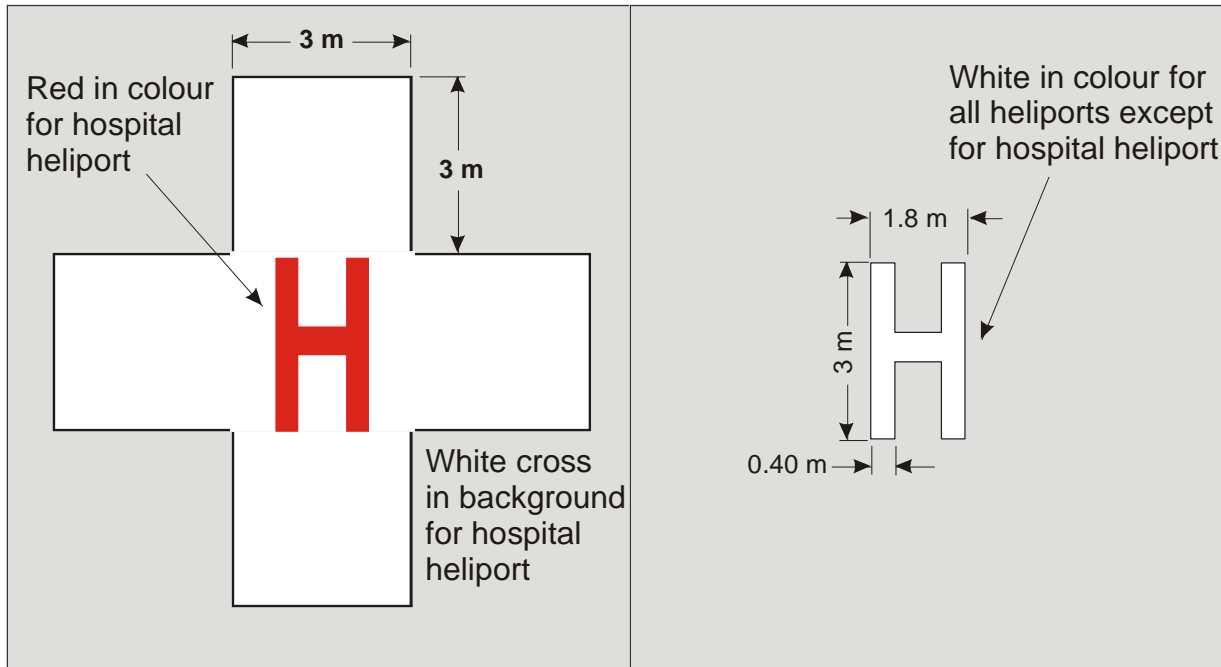

Figure 5-2. Hospital heliport identification and heliport identification marking

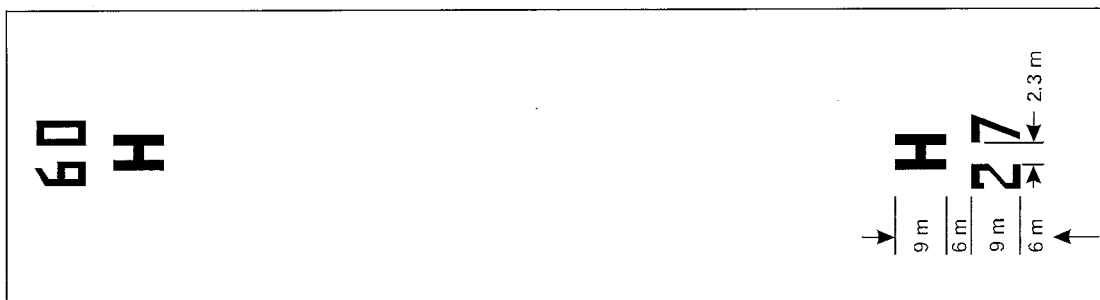

Figure 5-3. FATO designation marking and heliport identification marking for a runway-type FATO

5.2.2.57 A heliport identification marking shall be oriented with the cross arm of the H at right angles to the preferred final approach direction. For a helideck the cross arm shall be on or parallel to the bisector of the obstacle-free sector as shown in Figure 5-1. For a non-purpose built shipboard heliport located on a ship's side the cross arm shall be parallel with the side of the ship.

5.2.2.68 **Recommendation.**— *On a helideck and shipboard heliport the size of the heliport identification “H” marking should have a height of 4 m with an overall width not exceeding 3 m and a stroke width not exceeding 0.75 m.*

5.2.3 Maximum allowable mass marking

Application

5.2.3.1 **Recommendation.**— *A maximum allowable mass marking should shall be displayed at an elevated heliport, and at a helideck and a shipboard heliport.*

Note.— *For an elevated heliport, a helideck or a shipboard heliport designed with a FATO/TLOF of less than 1 D, the maximum allowable mass may be no greater than 3175 kg or 7000 lb.*

5.2.3.2 **Recommendation.**— *A maximum allowable mass marking should be displayed at a surface level heliport.*

Location

5.2.3.23 **Recommendation.**— *A maximum allowable mass marking should be located within the TLOF FATO or FATO/TLOF and so arranged as to be readable from the preferred final approach direction.*

Characteristics

5.2.3.34 A maximum allowable mass marking shall consist of a one-, two- or three-digit number. The marking shall be expressed in tonnes (1,000 kg) rounded to the nearest 1000 kg followed by a letter “t”. Where States use mass in pounds, the maximum allowable mass marking shall indicate the allowable helicopter mass in thousands of pounds rounded to the nearest 1000 lbs.

5.2.3.5 The maximum allowable mass shall be expressed in tonnes (1,000 kg) rounded to the nearest 1000 kg followed by a letter “t”. Where States use mass in pounds, the maximum allowable mass marking shall indicate the allowable helicopter mass in thousands of pounds rounded to the nearest 1000 lbs.

Note.— *Where States express the maximum allowable mass in pounds, it is not appropriate to suffix with the letter “t” which is used only to indicate metric tonnes. Guidance on markings where States use imperial units is given in the Heliport Manual (Doc 9261).*

5.2.3.46 **Recommendation.**— *The maximum allowable mass marking should be expressed to the nearest 100 kg. The marking should be presented to one decimal place and rounded to the nearest 100 kg followed by the letter “t”. Where States use mass in pounds, the maximum allowable mass marking should indicate the allowable helicopter mass in hundreds of pounds rounded to the nearest 100 lb.*

Editorial Note.— *Figure 5-2 moved and renumbered Figure 5-4 as follows:*

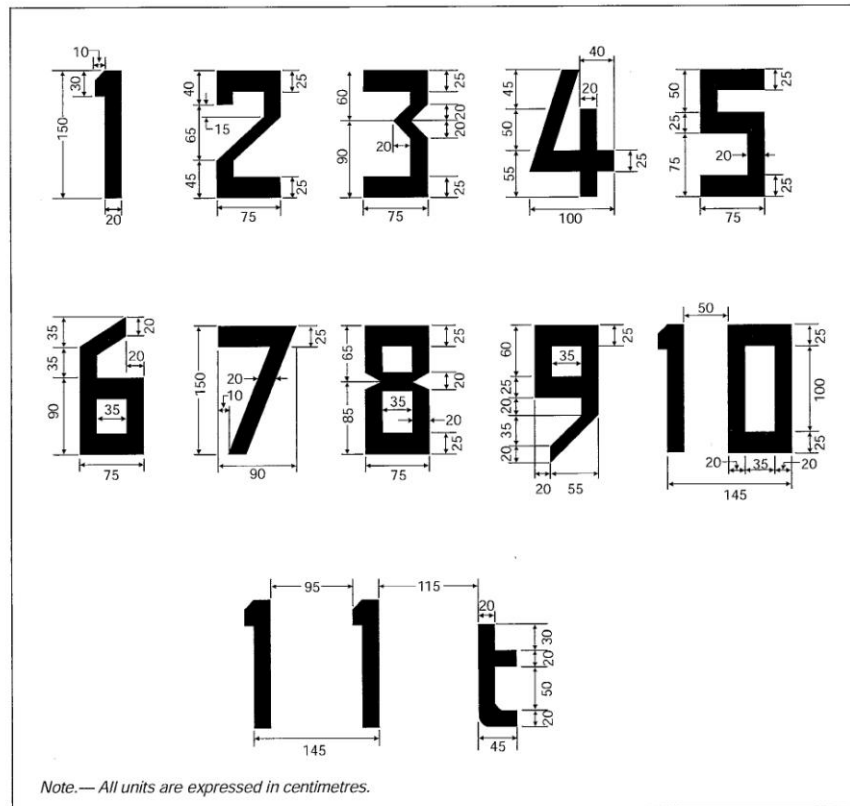

Figure 5-24. Form and proportions of numbers and letters for maximum allowable mass marking

5.2.3.6A Recommendation.— When the maximum allowable mass is expressed to 100 kg, the decimal place should be preceded with a decimal point marked with a 30 cm square.

All FATOs except runway-type FATOs

5.2.3.57 Recommendation.— The numbers and the letter of the marking should have a colour contrasting with the background and should be in the form and proportion shown in Figure 5-24, ~~except that~~ where space is limited, such as on an offshore helideck or shipboard heliport, it is permitted to reduce the size of the marking to characters with an overall height of not less than 90 cm with a corresponding reduction in the width and thickness of the figures for a FATO or FATO/TLOF with a dimension of more than 30 m. For a FATO or FATO/TLOF with a dimension of between 15 m to 30 m the height of the numbers and the letter of the marking should be a minimum of 90 cm, and for a FATO or FATO/TLOF with a dimension of less than 15 m the height of the numbers and the letter of the marking should be a minimum of 60 cm, each with a corresponding reduction in width and thickness.

Runway-type FATOs

5.2.3.8 **Recommendation.**— *The numbers and the letter of the marking should have a colour contrasting with the background and should be in the form and proportion shown in Figure 5-4.*

5.2.4 ~~Maximum allowable~~ D-value marking*Application*

5.2.4.1 **Recommendation.**— *The D-value marking should be displayed at an elevated heliport and at a helideck.*

All FATOs except runway-type FATOs

5.2.4.1 The D-value marking shall be displayed at a heliport designed for helicopters operated in performance Class 2 or 3, and at a helideck and at a shipboard heliport.

Runway-type FATOs

Note. —*The D-value is not required to be marked on a heliport with a runway-type FATO.*

Location

5.2.4.2 **Recommendation.**— A ~~maximum allowable~~ D-value marking ~~should~~ shall be located within the FATO or FATO/TLOF and so arranged as to be readable from the preferred final approach direction.

5.2.4.3 **Recommendation.**— *Where there is more than one approach direction, additional D-value markings should be provided such that at least one D-value marking is readable from the final approach directions. For a non-purpose built heliport located on a ship's side, D value markings should be provided on the perimeter of the D circle at the 2 o'clock, 10 o'clock and 12 o'clock positions when viewed from the side of the ship facing towards the centreline.*

Characteristics

5.2.4.34 The D-value shall be marked on the FATO or FATO/TLOF in a ~~contrasting colour to it,~~ preferably white. The D-value shall be rounded to the nearest whole ~~number~~ metre or foot with 0.5 rounded down. ~~e.g. 19.5 becomes 19 and 19.6 becomes 20.~~

5.2.4.5 **Recommendation.**— *The numbers of the marking should have a colour contrasting with the background and should be in the form and proportion shown in Figure 5-4 for a FATO or FATO/TLOF with a dimension of more than 30 m. For a FATO or FATO/TLOF with a dimension of between 15 m to 30 m the height of the numbers of the marking should be a minimum of 90 cm, and for a*

FATO or FATO/TLOF with a dimension of less than 15 m the height of the numbers of the marking should be a minimum of 60 cm, each with a corresponding reduction in width and thickness.

Editorial Note.— New sub-section on marking the actual FATO dimensions as follows:

5.2.5 Final approach and take-off dimension(s) marking

Application

5.2.5.1 Recommendation.—*The actual dimension(s) of the FATO or FATO/TLOF intended to be used by helicopters operated in performance class 1 should be marked on the FATO or FATO/TLOF.*

5.2.5.2 Recommendation.—*If the actual dimension(s) of the FATO or FATO/TLOF to be used by helicopters operated in performance class 2 or 3 is less than 1D, the dimension(s) should be marked on the FATO or FATO/TLOF.*

Location

5.2.5.3 A FATO or FATO/TLOF size marking shall be located within the FATO and so arranged as to be readable from the preferred final approach direction.

Characteristics

5.2.5.4 The dimension(s) shall be rounded to the nearest metre or foot.

Note.— *If the FATO or FATO/TLOF is square or rectangular both the length and width of the FATO or FATO/TLOF relative to the preferred final approach direction is indicated.*

All FATOs except runway-type FATOs

5.2.5.5 Recommendation.— *The numbers of the marking should have a colour contrasting with the background and should be in the form and proportion shown in Figure 5-4 for a FATO or FATO/TLOF with a dimension of more than 30 m. For a FATO or FATO/TLOF with a dimension between 15 m to 30 m the height of the numbers of the marking should be a minimum of 90 cm, and for a FATO or FATO/TLOF with a dimension of less than 15 m the height of the numbers of the marking should be a minimum of 60 cm, each with a corresponding reduction in width and thickness.*

Runway-type FATOs

5.2.5.6 Recommendation.— *The numbers of the marking should have a colour contrasting with the background and should be in the form and proportion shown in Figure 5-4.*

5.2.56 Final approach and take-off area perimeter marking or markers for surface level heliports

Application

5.2.56.1 FATO perimeter marking or markers shall be provided at a surface level heliport ~~on ground~~ where the extent of the FATO is not self-evident.

Location

5.2.56.2 The FATO perimeter marking or markers shall be located on the boundary edge of the FATO.

Characteristics - Runway-type FATOs

5.2.56.3 The perimeter of the FATO shall be defined with markings or markers ~~shall be spaced:~~

- a) ~~for a square or rectangular area, at equal intervals of not more than 50 m with at least three markings or markers on each side including a marking or marker at each corner; and~~
- b) ~~for any other shaped area, including a circular area, markings or markers shall be spaced at equal intervals of not more than 10 m with a minimum number of five markings or markers.~~

5.2.56.4 A FATO perimeter marking shall be a rectangular stripe with a length of 9 m or one-fifth of the side of the FATO which it defines and a width of 1 m. ~~Where a marker is used its characteristics shall conform to those specified in Annex 14, Volume I, 5.5.8.3 except that the height of the marker shall not exceed 25 cm above ground or snow level.~~

5.2.56.5 A FATO perimeter markings shall be white.

5.2.6.6 A FATO perimeter marker shall have dimensional characteristics as shown in Figure 5-5.

5.2.6.7 FATO perimeter markers shall be of colour(s) that contrast effectively against the operating background.

5.2.6.8 **Recommendation.**— FATO perimeter markers should be a single colour, orange or red, or two contrasting colours, orange and white or alternatively red and white should be used except where such colours would merge with the background.

Characteristics - All FATOs except runway-type FATOs

5.2.6.9 For an unpaved FATO the perimeter shall be defined with flush in-ground markers. The FATO perimeter markers shall be 30 cm in width, 1.5 m in length, and with end-to-end spacing of not less than 1.5 m and not more than 2 m. The corners of a square or rectangular FATO shall be defined.

5.2.6.10 For a paved FATO the perimeter shall be defined with a dashed line. The FATO perimeter marking segments shall be 30 cm in width, 1.5 m in length, and with end-to-end spacing of not less than 1.5 m and not more than 2 m. The corners of the square or rectangular FATO shall be defined.

5.2.6.11 FATO perimeter markings and flush in-ground markers shall be white.

Editorial Note.— New Figure 5-5:

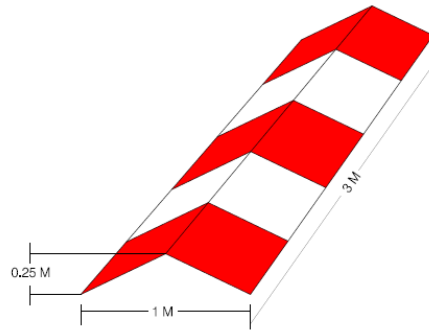

Figure 5-5 Runway-type FATO edge marker

5.2.67 Final approach and take-off area designation markings for runway-type FATO

Application

5.2.67.1 **Recommendation.**— A FATO designation marking should be provided at a heliport where it is necessary to designate the FATO to the pilot.

Location

5.2.67.2 A FATO designation marking shall be located at the beginning of the FATO as shown in Figure 5-3.

Characteristics

5.2.67.3 A FATO designation marking shall consist of a runway designation marking described in Annex 14, Volume I, 5.2.2.4 and 5.2.2.5, two-digit number. The two-digit number shall be the whole number nearest the one-tenth of the magnetic North when viewed from the direction of approach. When the above rule would give a single digit number, it shall be preceded by a zero. The marking as shown in Figure 5-3, shall be supplemented by an H, specified in 5.2.2.5 above, and as shown in Figure 5-3.

5.2.78 Aiming point marking

Application

5.2.78.1 **Recommendation.**— An aiming point marking should be provided at a heliport where it is necessary for a pilot to make an approach to a particular point above a FATO before proceeding to the TLOF.

Location - Runway-type FATOs

5.2.78.2 The aiming point marking shall be located within the FATO.

Location - All FATOs except runway-type FATOs

5.2.8.3 The aiming point marking shall be located at the centre of the FATO as shown in Figure 5-1.

Characteristics

5.2.78.3.4 The aiming point marking shall be an equilateral triangle with the bisector of one of the angles aligned with the preferred approach direction. The marking shall consist of continuous white lines, and the dimensions of the marking shall conform to those shown in Figure 5-46.

Editorial Note.— Figure 5-4 renumbered Figure 5-6 as follows:

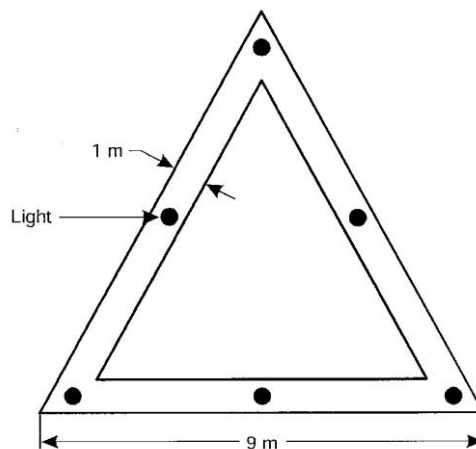

Figure 5-46. Aiming point marking

5.2.89 Touchdown and lift-off area perimeter marking

Application

5.2.8.1—TLOF marking shall be provided on a heliport if the perimeter of the TLOF is not self-evident.

5.2.9.1 A TLOF perimeter marking shall be displayed on a TLOF located in a FATO at a surface level heliport if the perimeter of the TLOF is not self-evident.

5.2.9.2 A TLOF perimeter marking shall be displayed on an elevated heliport, a helideck and a shipboard heliport.

5.2.9.3 **Recommendation.**— A TLOF perimeter marking should be provided on each TLOF collocated with a helicopter stand at a surface level heliport.

Location

5.2.89.24 The TLOF perimeter marking shall be located along the perimeter edge of the TLOF or FATO/TLOF.

Characteristics

5.2.89.35 A TLOF perimeter marking shall consist of a continuous white line with a width of at least 30 cm.

5.2.910 Touchdown/positioning marking

Application

5.2.910.1 A touchdown/positioning marking shall be provided where it is necessary for a helicopter to touch down ~~or~~ and/or be accurately ~~placed~~ positioned by the pilot ~~in a specific position~~. A touchdown/positioning marking shall be provided on a helicopter stand designed for turning.

Location

5.2.910.2 A touchdown/positioning marking shall be located so that when the pilot's seat is over the marking, the whole of the undercarriage will be ~~inside~~ within the ~~load-bearing area~~, TLOF or FATO/TLOF and all parts of the helicopter will be clear of any obstacle by a safe margin.

5.2.10.3 On a heliport the centre of the touchdown/positioning marking shall be located at the centre of the TLOF or FATO/TLOF, except the centre of the touchdown/positioning marking may be offset away from the centre of the TLOF or FATO/TLOF where an aeronautical study indicates such offsetting to be necessary and providing that a marking so offset would not adversely affect safety. For a

helicopter stand designed for hover turning, the touchdown/positioning marking shall be located in the centre of the central zone (see Figure 3-4).

5.2.910.34 On a helideck the centre of the touchdown/positioning marking shall be located at the centre of the FATO/TLOF, except that the marking centre may be offset away from the origin of the obstacle-free sector by no more than 0.1 D on helidecks with a FATO/TLOF of 1 D or greater where an aeronautical study indicates such offsetting to be necessary and providing that a marking so offset would not adversely affect the safety. For heliports located on the bow of a vessel, and for any helideck or shipboard heliport where the D value is 16.0m or less, the touchdown/positioning marking shall be located at the centre of the FATO/TLOF.

Note. See Heliport Manual (Doc 9261) for guidance.

~~*Note.— It is not considered appropriate to offset a touchdown marking on a heliport located on the bow of a vessel, or for any helideck where the D value is 16 m or less.*~~

Characteristics

5.2.910.45 A touchdown/positioning marking shall be a yellow circle and have a line width of at least 0.5 m. For a helideck and a purpose built shipboard heliport the line width shall be at least 1 m.

5.2.910.56 The inner diameter of the circle touchdown/positioning marking shall be 0.5 D of the largest helicopter the TLOF and/or FATO/TLOF and/or the helicopter stand is intended to serve.

~~5.2.9.6 When a net is located on the surface of a FATO, it shall be large enough to cover the whole of the touchdown/positioning marking and shall not obscure other essential markings.~~

5.2.4011 Heliport name marking

Application

5.2.4011.1 **Recommendation.**— A heliport name marking should be provided at a heliport and helideck where there is insufficient alternative means of visual identification.

Location

5.2.4011.2 **Recommendation.**— The heliport name marking should be placed displayed on the heliport so as to be visible, as far as practicable, at all angles above the horizontal. Where an obstacle sector exists on a helideck the marking should be located on the obstacle side of the H identification marking. For a non-purpose built heliport located on a ship's side the marking should be located on the inboard side of the H identification marking in the area between the continuous line TLOF perimeter marking and the broken line indicating the boundary of the LOS.

Characteristics

5.2.4011.3 A heliport name marking shall consist of the name or the alphanumeric designator of the heliport as used in the radiotelephony (R/T) communications.

Editorial Note.— 5.2.10.4 has been relocated to new 5.2.11.5 below.

5.2.10.54 **Recommendation.**— A heliport name marking intended for use at night or during conditions of poor visibility ~~shall~~ **should** be illuminated, either internally or externally.

Runway-type FATOs

5.2.11.45 **Recommendation.**— The characters of the marking should be not less than 3 m in height at surface level heliports and not less than 1.2 m on elevated heliports and helidecks. The colour of the marking should contrast with the background.

All FATOs except runway-type FATOs

5.2.11.6 **Recommendation.**— The characters of the marking should be not less than 1.5 m in height at surface level heliports and not less than 1.2 m on elevated heliports, helidecks and shipboard heliports. The colour of the marking should contrast with the background and preferably be white.

5.2.12 Helideck obstacle-free sector (chevron) marking

Application

5.2.12.1 **Recommendation.**— ~~A helideck obstacle-free sector marking should be provided at a helideck.~~ A helideck with adjacent obstacles that penetrate above the level of the helideck shall have an obstacle free sector marking.

Location

5.2.12.2 A helideck obstacle-free sector marking shall be located, where practicable, at a distance from the centre of the FATO/TLOF equal to the radius of the largest circle that can be drawn in the FATO/TLOF ~~on the FATO perimeter or on the TLOF marking~~ or 0.5D, whichever is greater.

Note.— Where the Point of Origin is outside the FATO/TLOF, and it is not practicable to physically paint the chevron, the chevron is relocated to the perimeter on the bisector of the OFS. In this case the distance and direction of displacement, along with the attention getting “WARNING DISPLACED CHEVRON”, with the distance and direction of displacement, is marked in a box beneath the chevron in black characters not less than 10cm high – an example Figure is given in the Heliport Manual.

Characteristics

5.2.12.3 The helideck obstacle-free sector marking shall indicate the origin location of the obstacle-free sector and the directions of the limits of the sector. Example figures are given in the Heliport Manual (Doc 9261).

Note. Example figures are given in the Heliport Manual (Doc 9261).

5.2.12.4 The height of the chevron shall equal the width of the TLOF marking but shall be not be less than 30 cm.

5.2.12.5 The chevron shall be marked in a conspicuous colour.

5.2.12.6 Recommendation. — *The colour of the Chevron should be black.*

5.2.13 Helideck and shipboard heliport surface marking

Application

5.2.13.1 Recommendation.— *A surface marking should be provided to assist the pilot to identify the location of the helideck or shipboard heliport during an approach by day.*

Location

5.2.13.2 Recommendation.— *A surface marking should be applied to the dynamic load bearing area bounded by the TLOF perimeter marking.*

Characteristics

5.2.13.3 Recommendation.— *The helideck or shipboard heliport surface bounded by the FATO/TLOF perimeter marking should be of a dark colour green using a high friction coating. Where the surface coating may have a degrading effect on friction qualities, it may be necessary to leave the helideck surface untreated. In such cases, the conspicuity of the markings should be enhanced by outlining the deck markings with a contrasting colour.*

Note. - *Where the application of a surface coating may have a degrading effect on friction qualities it may be necessary to leave the surface unpainted. In such cases the conspicuity of markings will need to be enhanced by outlining deck markings with a contrasting colour.*

5.2.14 Helideck prohibited landing sector markings

Application

5.2.14.1 Recommendation.— *Helideck prohibited landing sector markings should be provided where it is necessary to prevent the helicopter from landing within specified headings.*

Location

5.2.13 5.2.14.2 **Recommendation.**— The prohibited landing sector markings should shall be located on the touchdown/positioning marking to the edge of the FATO/TLOF, within the relevant headings as shown in Figure 5-5.

Characteristics

5.2.13 5.2.14.3 The prohibited landing sector markings shall be indicated by white and red hatched markings as shown in Figure 5-57.



Figure 5.57 Helideck prohibited landing sector markings

Note.— Prohibited landing sector markings, where deemed necessary, are applied to indicate a range of helicopter headings that are not to be used by a helicopter when landing. This is to ensure that the nose of the helicopter is kept clear of the hatched markings during the manoeuvre to land.

5.2.14 — Markings and markers for helicopter taxiways

Note.— ~~The specifications for taxiway centre line marking and taxi holding position markings in Annex 14, Volume I, 5.2.8 and 5.2.9 are equally applicable to taxiways intended for ground taxiing of helicopters.~~

5.2.15 Helicopter ground taxiway markings and markers

Note 1.— ~~The specifications for taxi-holding position markings in Annex 14, Volume I, 5.2.10 are equally applicable to taxiways intended for ground taxiing of helicopters.~~

Note 2.- Ground taxi-routes are not required to be marked.

Application

5.2.15.1. **Recommendation.** -- *The centre line of a ground taxiway should be identified with a marking and the edges of a ground taxiway, if not self evident, should be identified with markers or markings.*

Location

5.2.15.2 Ground taxiway markings shall be along the centre line and, if required, along the edges of a ground taxiway.

5.2.15.3 Ground taxiway edge markers shall be located at a distance of 0.5m to 3m beyond the edge of the taxiway.

5.2.15.4 Ground taxiway edge markers, where provided, shall be spaced at intervals of not more than 15 m on each side of straight sections and 7.5 m on each side of curved sections with a minimum of four equally spaced markers per section.

Characteristics

5.2.15.5 A ground taxiway centre line marking shall be a continuous yellow line 15 cm in width.

5.2.15.6 Ground taxiway edge markings shall be a continuous double yellow line, each 15 cm in width, and spaced 15 cm apart (nearest edge to nearest edge).

Note.- Signage may be required on an aerodrome where it is necessary to indicate that a ground taxiway is suitable only for the use of helicopters.

5.2.15.7 A ground taxiway edge marker shall be frangible.

5.2.15.8 A ground taxiway edge marker shall not exceed a plane originating at a height of 25 cm above the plane of the ground taxiway, at a distance of 0.5m from the edge of the taxiway and sloping upwards and outwards at a gradient of 5 per cent to a distance of 3m beyond the edge of the ground taxiway.

5.2.15.9 A ground taxiway edge marker shall be blue.

Note 1.- Guidance on suitable edge markers is given in the Heliport Manual (Doc 9261).

Note 2.- If blue markers are used on an aerodrome, signage may be required to indicate that the ground taxiway is suitable only for helicopters.

5.2.15.10 If the ground taxiway is to be used at night, the edge markers shall be internally illuminated or retro-reflective.

5.2.1516 Helicopter Air taxiway markings and markers

Note. - Air taxi-routes are not required to be marked.

Application

5.2.15.1 ~~Recommendation.~~ *An air taxiway should be marked with air taxiway markers.*

5.2.16.1. **Recommendation.** -- *The centre line of an air taxiway or, if not self evident, the edges of an air taxiway should be identified with markers or markings.*

Note.—*These markers are not meant to be used on helicopter ground taxiways.*

Location

5.2.1516.2 An Air taxiway centre line marking or flush in-ground centreline markers shall be located along the centre line of the air taxiway and shall be spaced at intervals of not more than 30 m on straight sections and 15 m on curves.

5.2.16.3 Air taxiway edge markers shall be located at a distance of 1 m to 3m beyond the edge of the air taxiway.

5.2.16.4 **Recommendation.**— *Air taxiway edge markers should not be located at a distance of less than 0.5 of the largest overall width of the helicopter for which designed from the centre line of the air taxiway.*

Characteristics

5.2.16.5 An air taxiway centre line, when on a paved surface, shall be marked with a continuous yellow line 15 cm in width

5.2.16.6 The edges of an air taxiway, when on a paved surface, shall be marked with continuous double yellow lines each 15 cm in width, and spaced 15 cm apart (nearest edge to nearest edge).

Note.- Where there is potential for an air taxiway to be confused with a ground taxiway, signage may be required to indicate the mode of taxi operations that are permitted.

5.2.16.7 An air taxiway centre line, when on an unpaved surface that will not accommodate painted markings, shall be marked with flush in-ground 15 cm wide and approximately 1.5 m in length yellow markers, spaced at intervals of not more than 30 m on straight sections and not more than 15 m on curves, with a minimum of four equally spaced markers per section.

5.2.16.8 Air taxiway edge markers, where provided, shall be spaced at intervals of not more than 30 m on each side of straight sections and not more than 15 m on each side of curves, with a minimum of four equally spaced markers per section.

5.2.16.9 Air taxiway edge markers shall be frangible.

5.2.16.10 Air taxiway edge markers shall not penetrate a plane originating at a height of 25 cm above the plane of the taxiway, at a distance of 1 m from the edge of the taxiway and sloping upwards and outwards at a gradient of 5 per cent to a distance of 3m beyond the edge of the air taxiway.

5.2.16.11 **Recommendation.**— *Air taxiway edge markers should not penetrate a plane originating at a height of 25 cm above the plane of the taxiway, at a distance of 0.5 of largest overall width of the helicopter for which designed from the centre line of the taxiway, and sloping upwards and outwards at a gradient of 5 per cent.*

~~5.2.15.3~~ An air taxiway marker shall be frangible and when installed shall not exceed 35 cm above ground or snow level. The surface of the marker as viewed by the pilot shall be a rectangle with a height to width ratio of approximately 3 to 1 and shall have a minimum area of 150 cm² as shown in Figure 5-6.

~~5.2.15.4~~ 5.2.16.412 An air taxiway edge marker shall be divided into three equal, horizontal bands coloured yellow, green and yellow, respectively. If the air taxiway is to be used at night, the markers shall be internally illuminated or retro-reflective of colour(s) that contrast effectively against the operating background. The colour red shall not be used for markers.

Note.- Guidance for suitable edge markers is given in the Heliport Manual (Doc 9261).

5.2.16.13 If the air taxiway is to be used at night, air taxiway edge markers shall be either internally illuminated or retro-reflective.

Editorial Note.— Current Figure 5-6 to be deleted.

5.2.16 Air transit route markers.

Application

~~5.2.16.1~~ **Recommendation.**— *When established an air transit route should be marked with air transit route markers.*

Location

5.2.16.2 Air transit route markers shall be located along the centre line of the air transit route and shall be spaced at intervals of not more than 60 m on straight sections and 15 m on curves.

Characteristics

~~5.2.16.3~~ An air transit route marker shall be frangible and when installed shall not exceed 1m above ground or snow level. The surface of the marker as viewed by the pilot shall be a rectangle with a height to width ratio of approximately 1 to 3 and shall have a minimum area of 1500 cm² as shown in the examples in Figure 5-7.

~~5.2.16.4— An air transit route marker shall be divided into three equal, vertical bands coloured yellow, green blue and yellow, respectively. If the air transit route is to be used by night, the marker shall be internally illuminated or retro reflective.~~

Editorial Note.— Current Figure 5-7 to be deleted.

Editorial Note.— New sub-section on marking a Helicopter Stand

5.2.17 Helicopter stand markings

Application

5.2.17.1 A helicopter stand perimeter marking shall be provided on a helicopter stand designed for turning. If a helicopter stand perimeter marking is not practicable, a central zone perimeter marking shall be provided instead if the perimeter of the central zone is not self-evident.

5.2.17.2 For a helicopter stand intended to be used for taxi-through and which does not allow the helicopter to turn, a stop line shall be provided.

5.2.17.3 **Recommendation.** - *Alignment lines and lead-in/lead-out lines should be provided on a helicopter stand.*

Note 1.— See Figure 5-8.

Note 2.- Helicopter stand identification markings may be provided where there is a need to identify individual stands.

Note 3.- Additional markings relating to stand size may be provided. See Heliport Manual (Doc 9261).

Location

5.2.17.4 A helicopter stand perimeter marking on a helicopter stand designed for turning or, a central zone perimeter marking, shall be concentric with the central zone of the stand.

5.2.17.5 For a helicopter stand intended to be used for taxi-through and which does not allow the helicopter to turn, a stop line shall be located on the taxiway axis at right angles to the centreline.

5.2.17.6 Alignment lines and lead-in/lead-out lines shall be located as shown in Figure 5-8.

Characteristics

5.2.17.7 A helicopter stand perimeter marking shall be a yellow circle and have a line width of 15 cm.

5.2.17.8 A central zone perimeter marking shall be a yellow circle and have a line width of 15 cm, except when the TLOF is collocated with a helicopter stand, the characteristics of the TLOF perimeter markings shall apply.

5.2.17.9 *For a helicopter stand intended to be used for taxi-through and which does not allow the helicopter to turn, a yellow stop line shall not be less than the width of the taxiway and have a line thickness of 50 cm.*

5.2.17.10 Alignment lines and lead-in/lead-out lines shall be continuous yellow lines and have a width of 15 cm.

5.2.17.11 Curved portions of alignment lines and lead-in/lead-out lines shall have radii appropriate to the most demanding helicopter type the helicopter stand is intended to serve.

5.2.17.12. Stand identification markings shall be marked in a contrasting colour so as to be easily readable.

Note 1.- Where it is intended that helicopters proceed in one direction only, arrows indicating the direction to be followed may be added as part of the alignment lines.

Note 2.- The characteristics of markings related to the stand size, and alignment and lead-in/lead-out lines are illustrated in Figure 5-8.

Editorial Note.— New Figure 5-8:

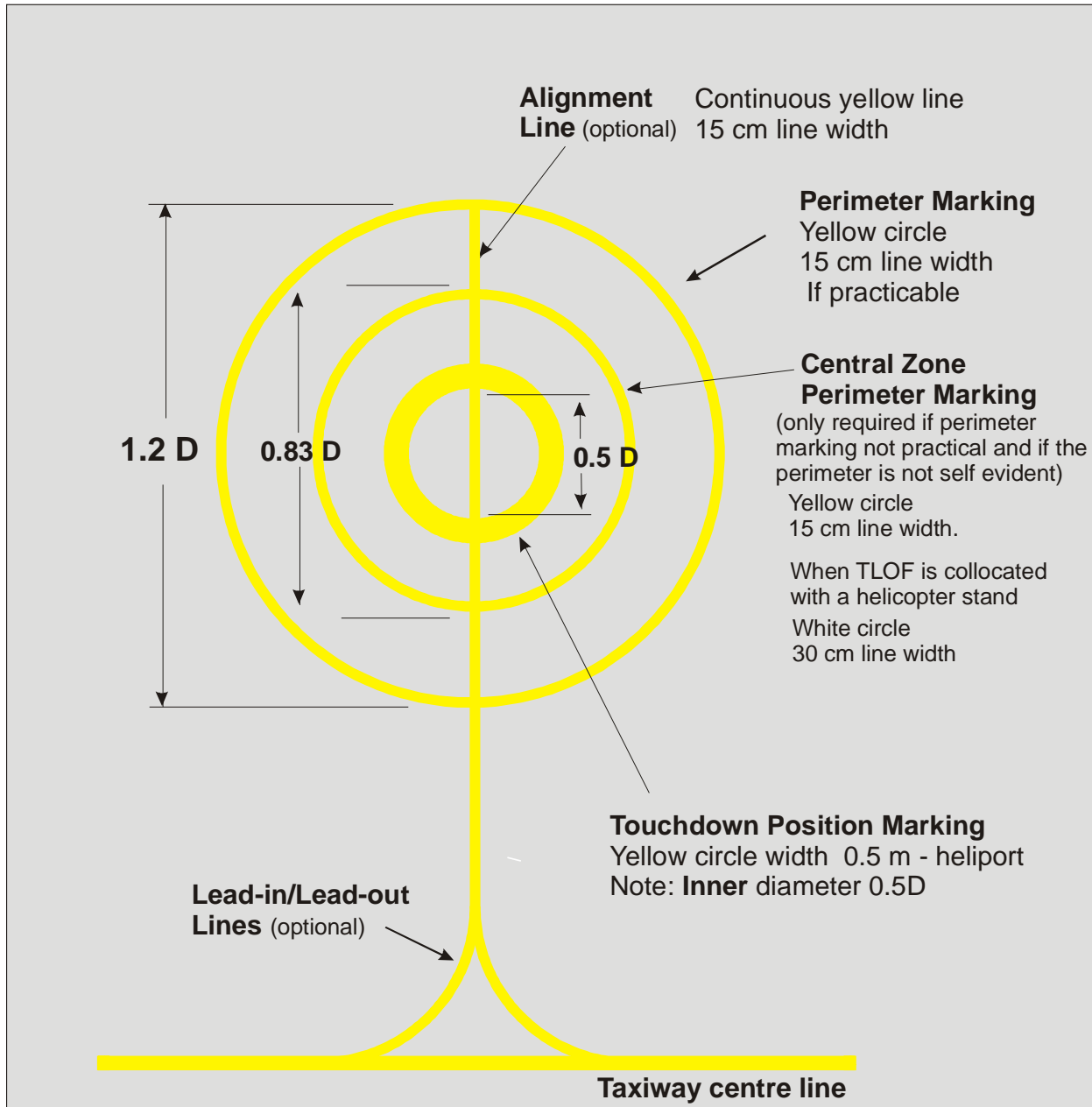

Figure 5-8 Helicopter stand designed for hover-turning markings

Editorial Note.— New sub-section on flight path alignment guidance marking

5.2.18 Flight path alignment guidance marking

Application

5.2.18.1 **Recommendation.**— *Flight path alignment guidance marking(s) should be provided at a heliport where it is desirable and practicable to indicate available approach and/or take-off flight path direction(s).*

Note.— *The flight path alignment guidance marking can be combined with a flight path alignment guidance lighting system described in 5.3.3A.*

Location

5.2.18.2 The flight path alignment guidance marking shall be located in a straight line along the direction of approach and/or take-off flight path on one or more of the TLOF, FATO, FATO/TLOF, safety area or any suitable surface in the immediate vicinity of the FATO or safety area.

Characteristics

5.2.18.3 A flight path alignment guidance marking shall consist of one or more arrows marked on the TLOF, FATO or FATO/TLOF and/or safety area surface as shown in Figure 5-9. The stroke of the arrow(s) shall be 50 cm in width and at least 3 m in length. When combined with a flight path alignment guidance lighting system it shall take the form shown in Figure 5-9 which includes scheme for marking 'heads of the arrows' which are constant regardless of stroke length.

Note. — *In the case of a flight path limited to a single approach direction or single take-off direction, the arrow marking may be uni-directional. In the case of a heliport with only a single approach /take-off flight path available, one bi-directional arrow is marked.*

5.2.18.4 **Recommendation.**— *The markings should be in a colour which provides good contrast against the background colour of the surface on which they are marked.*

Editorial Note.— *New Figure 5-9:*

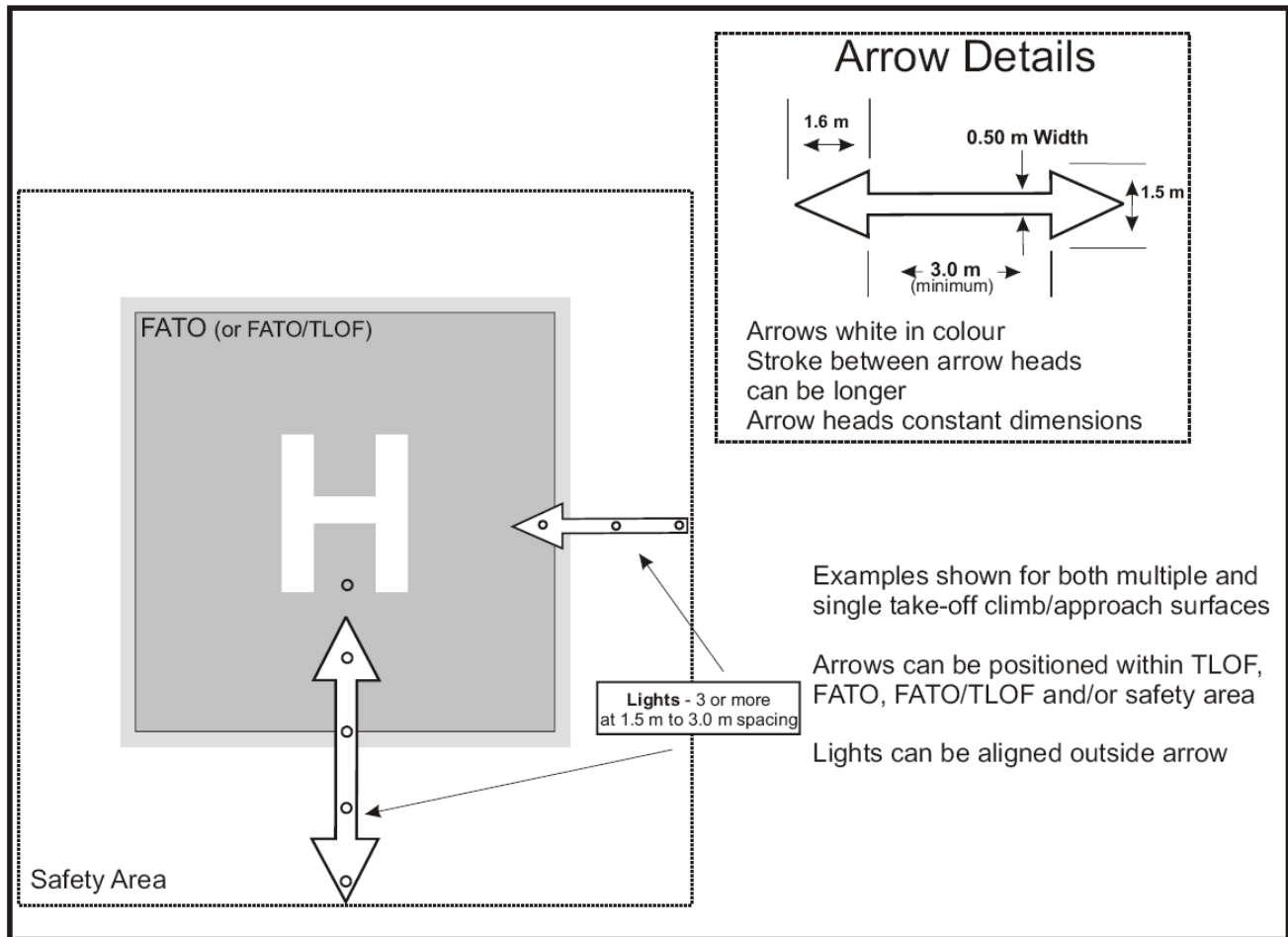

Figure 5-9 Flight path alignment guidance markings and lights

Rationale

For surface level, elevated heliports, helidecks and shipboard heliports minor editorial changes made to bring the text in line with the introduction in Chapter 3 of a FATO/TLOF designation and separate requirements for "runway-type FATO" and "All FATOs except runway-type FATOs."

Three Notes have been introduced following the main Chapter 5 heading to stress (i) the conspicuity of white and yellow markings can be improved by outlining them in black, (ii) guidance is given in the Heliport Manual to avoid confusion between markings where metric units are used and markings where imperial units are use, and (iii) for non-purpose built heliports located on a ship's side the surface colour of the main deck can vary from ship to ship, meaning some discretion may be needed in the colour selection of the heliport paint schemes.

A complete new sub-section to cover helicopter stand markings, not addressed in the current annex, and for surface level and elevated heliports a new section on flight path alignment guidance marking, to allow marking of the 'flight path' direction(s) with one or more arrows, has been added.

5.3 Lights

Note 4. — The following specifications have been developed for systems intended for use in conjunction with a non-instrument or non-precision FATO.

Note 4 — Specifications in sections 5.3.4, 5.3.6, 5.3.7, and 5.3.8 are designed to provide effective lighting systems based on night conditions. Where lights are to be used in conditions other than night (i.e. - day or twilight) it may be necessary to increase the intensity of the lighting to maintain effective visual cues by use of a suitable brilliancy control. Guidance is provided in the Aerodrome Design Manual (Doc 9157), Part 4 Visual Aids, Chapter 5 Light Intensity Settings.

.....

Editorial Note.— Delete Figure 5-7 from this section [New Figure 5.7 in section 5.2].

...

Editorial Note.— Renumber existing Figure 5-8 as new Figure 5-10, and change reference in text.

.....

Editorial Note.— Figure 5-9: renumber to Figure 5-11 and change title as indicated and change title of Illustration 6 and Note under Illustration 6 to that indicated below. Add white light.

Title - Illustration 6 of Figure 5-9 renumbered to Figure 5-11.

Illustration 6 - ~~Touchdown and lift-off area~~ TLOF perimeter lights, FATO/TLOF perimeter lights and flight path alignment guidance lighting system

Note and colour addition under Illustration 6.

(green or white light)

Note - Additional values may be required in the case of installations requiring identification by means of the lights at an elevation of less than two degrees

Amended title for existing Figure 5-9

**Figure 5-911. Isocandela diagrams of lights meant for
Helicopter non-instrument and non-precision approaches**

...

Editorial Note.— Renumber existing Figure 5-10 as Figure 5-12.

...

Editorial Note.— 5.3.3.4 and 5.3.3.6 are deleted here and transferred to Appendix 2. Renumber 5.3.3.5 to 5.3.3.4, 5.3.3.7 to 5.3.3.5, 5.3.3.8 to 5.3.3.6 and 5.3.3.9 to 5.3.3.7.

.....

~~5.3.3.4 **Recommendation.**— Where an approach lighting system is provided for a non-precision FATO, the system should not be less than 210 m in length~~

.....

~~5.3.3.6 **Recommendation.**— The light distribution of steady lights should be as indicated in Figure 5-9, Illustration 2 except that the intensity should be increased by a factor of 3 for a non-precision FATO.~~

.....

Editorial Note.— Insert new Section 5.3.4. Renumber all subsequent subsections: existing 5.3.4 to 5.3.5, etc.

5.3.4 Flight path alignment guidance lighting system

Application

5.3.4.1 *Recommendation.*— *Flight path alignment guidance lighting system(s) should be provided at a heliport where it is desirable and practicable to indicate available approach and/or take-off flight path direction(s).*

Note.— *The flight path alignment guidance lighting can be combined with a flight path alignment guidance marking(s) described in 5.2.18.*

Location

5.3.4.2 The flight path alignment guidance lighting system shall be in a straight line along the direction(s) of approach and/or take-off flight path on one or more of the TLOF, FATO, FATO/TLOF safety area or any suitable surface in the immediate vicinity of the FATO, FATO/TLOF or safety area.

5.3.4.3 **Recommendation.**— *If combined with a flight path alignment guidance marking, as far as is practicable the lights should be located inside the ‘arrow’ markings.*

Characteristics

5.3.4.4 **Recommendation**—*A flight path alignment guidance lighting system should consist of a row of three or more lights spaced uniformly a total minimum distance of 6 m. Intervals between lights should not be less than 1.5 m and should not exceed 3 m. Where space permits there should be 5 lights. See Figure 5-9.*

Note.— The number of lights and spacing between these lights may be adjusted to reflect the space available. If more than one flight path alignment system is used to indicate available approach and/or take-off flight path direction(s), the characteristics for each system are typically kept the same. See Figure 5-9.

5.3.4.5 The lights shall be steady omnidirectional inset white lights.

5.3.4.6 **Recommendation.** *The distribution of the lights should be as indicated in Figure 5-11, Illustration 6.*

5.3.4.7 **Recommendation.**— *A suitable control should be incorporated to allow for adjustment of light intensity to meet the prevailing conditions and to balance the flight path alignment guidance lighting system with other heliport lights and general lighting that may be present around the heliport*

.....

Editorial Note.— Again, renumber subsequent subsections: existing 5.3.4 to 5.3.5, etc.

...

Editorial Note.— Renumber existing Figure 5-11 as Figure 5-13.

.....

Editorial Note.— Replace Table 5-1 with new Table 5-1 as follows: information in Table 5-1 related to non-precision FATO transferred to Table A5-1 in Appendix 2.

Table 5-1. Dimensions and slopes of the obstacle protection surface

SURFACE AND DIMENSIONS	NON-INSTRUMENT FATO		NON-PRECISION FATO
Length of inner edge	Width of safety area		Width of safety area
Distance from end of FATO	3 m minimum		60 m
Divergence	10%		15%
Total length	2 500 m		2 500 m
Slope	PAPI	A ^a - 0.57°	A ^a - 0.57°
	HAPI	A ^b - 0.65°	A ^b - 0.65°
	APAPI	A ^a - 0.9°	A ^a - 0.9°
a.As indicated in Annex 14, Volume I, Figure 5-1219.			
b.The angle of the upper boundary of the “below slope” signal.			

.....

Editorial Note.— Renumber existing Figure 5-12 as Figure 5-14.

...

Editorial Note.— Renumber existing Figure 5-13 as Figure 5-15.

...

5.3.67 Final approach and take-off area lights lighting systems for surface level heliports

.....

5.3.89 Touchdown and lift-off area lighting system

Note.- This subsection also applies to a FATO/TLOF lighting system

.....

APPENDIX 1. AERONAUTICAL DATA QUALITY REQUIREMENTS

Table A1-1. Latitude and longitude

Latitude and longitude	Accuracy Data type	Integrity Classification
Heliport reference point	30 m surveyed/calculated	1×10^{-3} routine
Nav aids located at the heliport	3 m surveyed	1×10^{-5} essential
Obstacles in Area 3	0.5 m surveyed	1×10^{-5} essential
Obstacles in Area 2 (the part within the heliport boundary)	5 m surveyed	1×10^{-5} essential
Geometric centre of TLOF or FATO thresholds	1 m surveyed	1×10^{-8} critical
Ground taxiway centre line points, and air taxiway and transit route points	0.5 m surveyed/calculated	1×10^{-5} essential
Ground taxiway intersection marking line	0.5 m surveyed	1×10^{-5} essential
Ground exit guidance line	0.5 m surveyed	1×10^{-5} essential
Apron boundaries (polygon)	1 m surveyed	1×10^{-3} routine
De-icing/anti-icing facility (polygon)	1 m surveyed	1×10^{-3} routine
Helicopter standpoints/INS checkpoints	0.5 m surveyed	1×10^{-3} routine

Note 1.— See Annex 15, Appendix 8, for graphical illustrations of obstacle data collection surfaces and criteria used to identify obstacles in the defined areas.

Note 2.— Implementation of Annex 15, provision 10.6.1.2, concerning the availability, as of 18 November 2010, of obstacle data according to Area 2 and Area 3 specifications would be facilitated by appropriate advance planning for the collection and processing of such data.

Table A1-2. Elevation/altitude/height

Elevation/altitude/height	Accuracy Data type	Integrity Classification
Heliport elevation	0.5 m surveyed	1 × 10 ⁻⁵ essential
WGS-84 geoid undulation at heliport elevation position	0.5 m surveyed	1 × 10 ⁻⁵ essential
FATO threshold, non-precision approaches For heliports with or without a PinS approach	0.5 m surveyed	1 × 10 ⁻⁵ essential
WGS-84 geoid undulation at FATO threshold, TLOF geometric centre, non-precision approaches for heliports with or without a PinS approach	0.5 m surveyed	1 × 10 ⁻⁵ essential
FATO threshold, precision approaches for heliports intended to be operated in accordance with Appendix 2	0.25 m surveyed	1 × 10 ⁻⁸ critical
WGS-84 geoid undulation at FATO threshold, TLOF geometric centre, precision approaches for heliports intended to be operated in accordance with Appendix 2	0.25 m surveyed	1 × 10 ⁻⁸ critical
Ground taxiway centre line points, and air taxiway and transit route points	1 m surveyed	1 × 10 ⁻⁵ essential
Obstacles in Area 2 (the part within the heliport boundary)	3 m surveyed	1 × 10 ⁻⁵ essential
Obstacles in Area 3	0.5 m surveyed	1 × 10 ⁻⁵ essential
Distance measuring equipment/precision (DME/P)	3 m surveyed	1 × 10 ⁻⁵ essential

Note 1.— See Annex 15, Appendix 8, for graphical illustrations of obstacle data collection surfaces and criteria used to identify obstacles in the defined areas.

Note 2.— Implementation of Annex 15, provision 10.6.1.2, concerning the availability, as of 18 November 2010, of obstacle data according to Area 2 and Area 3 specifications would be facilitated by appropriate advance planning for the collection and processing of such data.

Table A1-3. Declination and magnetic variation

Declination/variation	Accuracy Data type	Integrity Classification
Helipport magnetic variation	1 degree surveyed	1×10^{-5} essential
ILS localizer antenna magnetic variation	1 degree surveyed	1×10^{-5} essential
MLS azimuth antenna magnetic variation	1 degree surveyed	1×10^{-5} essential

Table A1-4. Bearing

Bearing	Accuracy Data type	Integrity Classification
ILS localizer alignment	1/100 degree surveyed	1×10^{-5} essential
MLS zero azimuth alignment	1/100 degree surveyed	1×10^{-5} essential
FATO bearing (true)	1/100 degree surveyed	1×10^{-3} routine

Table A1-5. Length/distance/dimension

Length/distance/dimension	Accuracy Data type	Integrity Classification
FATO length, TLOF dimensions	1 m surveyed	1×10^{-8} critical
Clearway length and width	1 m surveyed	1×10^{-5} essential
Landing distance available	1 m surveyed	1×10^{-8} critical
Take-off distance available	1 m surveyed	1×10^{-8} critical
Rejected take-off distance available	1 m surveyed	1×10^{-8} critical
Taxiway/ <u>taxi-route</u> width	1 m surveyed	1×10^{-5} essential
ILS localizer antenna-FATO end, distance	3 m calculated	1×10^{-3} routine
ILS glide slope antenna-threshold, distance along centre line	3 m calculated	1×10^{-3} routine
ILS marker-threshold distance	3 m calculated	1×10^{-5} essential
ILS DME antenna-threshold, distance along centre line	3 m calculated	1×10^{-5} essential
MLS azimuth antenna-FATO end, distance	3 m calculated	1×10^{-3} routine
MLS elevation antenna-threshold, distance along centre line.....	3 m calculated	1×10^{-3} routine
MLS DME/P antenna-threshold, distance along centre line	3 m calculated	1×10^{-5} essential

APPENDIX 2

INTERNATIONAL STANDARDS AND RECOMMENDED PRACTICES FOR INSTRUMENT HELIPORTS WITH NON-PRECISION AND/OR PRECISION APPROACHES AND INSTRUMENT DEPARTURES

CHAPTER 1. GENERAL

Introductory Note.- Annex 14, Volume II, contains Standards and Recommended Practices (specifications) that prescribe the physical characteristics and obstacle limitation surfaces to be provided for at heliports, and certain facilities and technical services normally provided at a heliport. It is not intended that these specifications limit or regulate the operation of an aircraft.

Note 1.- The specifications in this appendix describe additional conditions beyond those found in the main sections of Annex 14, Volume II, that apply to instrument heliports with non-precision and/or precision approaches. All specifications contained within the main chapters of Annex 14, Volume II are equally applicable to instrument heliports, but with reference to further provisions described in this Appendix.

CHAPTER 2. HELIPORT DATA

2.3 Heliport Elevation

2.3.1 The elevation of the TLOF and/or the elevation and geoid undulation of each threshold of the FATO or FATO/TLOF (where appropriate) shall be measured and reported to the aeronautical information services authority to the accuracy of:

- a) one-half metre or foot for non-precision approaches; and
- b) one-quarter metre or foot for precision approaches.

Note.— Geoid undulation must be measured in accordance with the appropriate system of coordinates.

2.4 Heliport dimensions and related information

2.4.1 The following additional data shall be measured or described, as appropriate, for each facility provided on an instrument heliport:

- a) distances to the nearest metre or foot of localizer and glide path elements comprising an instrument landing system (ILS) or azimuth and elevation antenna of a microwave landing system (MLS) in relation to the associated TLOF or FATO extremities.

CHAPTER 3. PHYSICAL CHARACTERISTICS

3.1 Surface-level and elevated heliports

Safety Areas

3.1.1 A safety area surrounding an instrument FATO or FATO/TLOF shall extend:

- a) laterally to a distance of at least 45 m on each side of the centre line; and
 b) longitudinally to a distance of at least 60 m beyond the ends of the FATO.

Note.- See Figure A3-1.

Editorial Note.— This is existing Figure 3-1 relocated to Appendix 2.

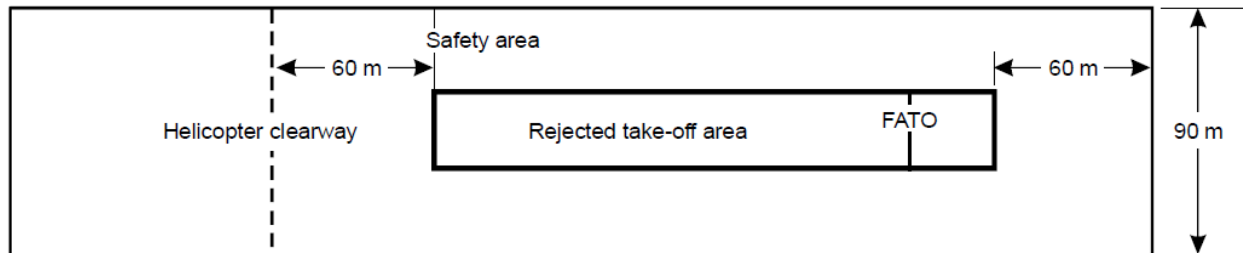

Figure A3-1. Safety Area for Instrument FATO

CHAPTER 4. OBSTACLE ENVIRONMENT

4.1 Obstacle limitation surfaces and sectors

Approach surface

4.1.1 *Characteristics.* The limits of an approach surface shall comprise:

- a) an inner edge horizontal and equal in length to the minimum specified width of the FATO plus the safety area, perpendicular to the centre line of the approach surface and located at the outer edge of the safety area;
- b) two side edges originating at the ends of the inner edge;
 - i) for an instrument FATO with a non-precision approach, diverging uniformly at a specified rate from the vertical plane containing the centre line of the FATO
 - ii) for an instrument FATO with a precision approach, diverging uniformly at a specified rate from the vertical plane containing the centre line of the FATO, to a specified height above FATO, and then diverging uniformly at a specified rate to a specified final width and continuing thereafter at that width for the remaining length of the approach surface; and
- c) an outer edge horizontal and perpendicular to the centre line of the approach surface and at a specified height above the elevation of the FATO.

4.2 Obstacle Limitation Requirements

4.2.1 The following obstacle limitation surfaces shall be established for an instrument FATO with a non-precision and/or precision approach:

- a) take-off climb surface;
- b) approach surface; and
- c) transitional surfaces.

Note.- See Figure A4-1 to A4-4

Editorial Note.— This is existing Figure 4-5 relocated to Appendix 2.

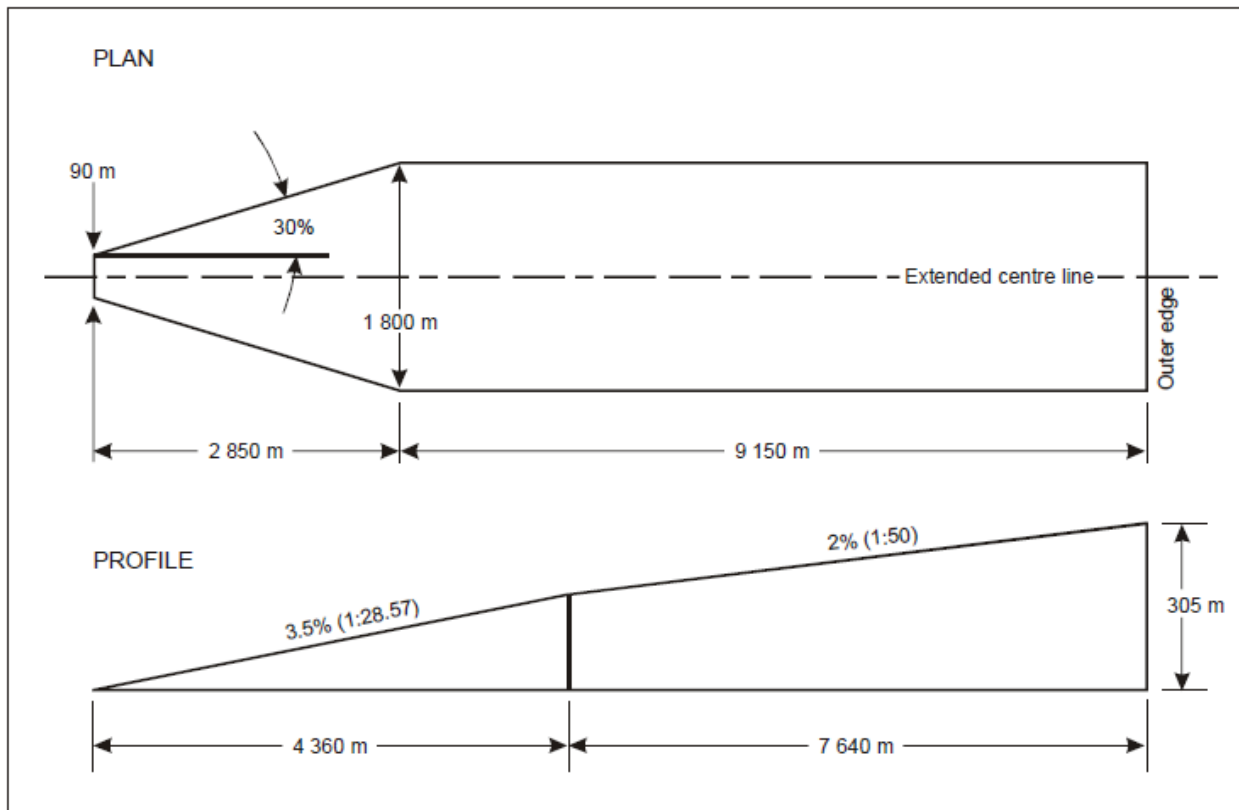

Figure A4-1. Take-off climb Surface for Instrument FATO

Editorial Note.— This is existing Figure 4-6 relocated to Appendix 2.

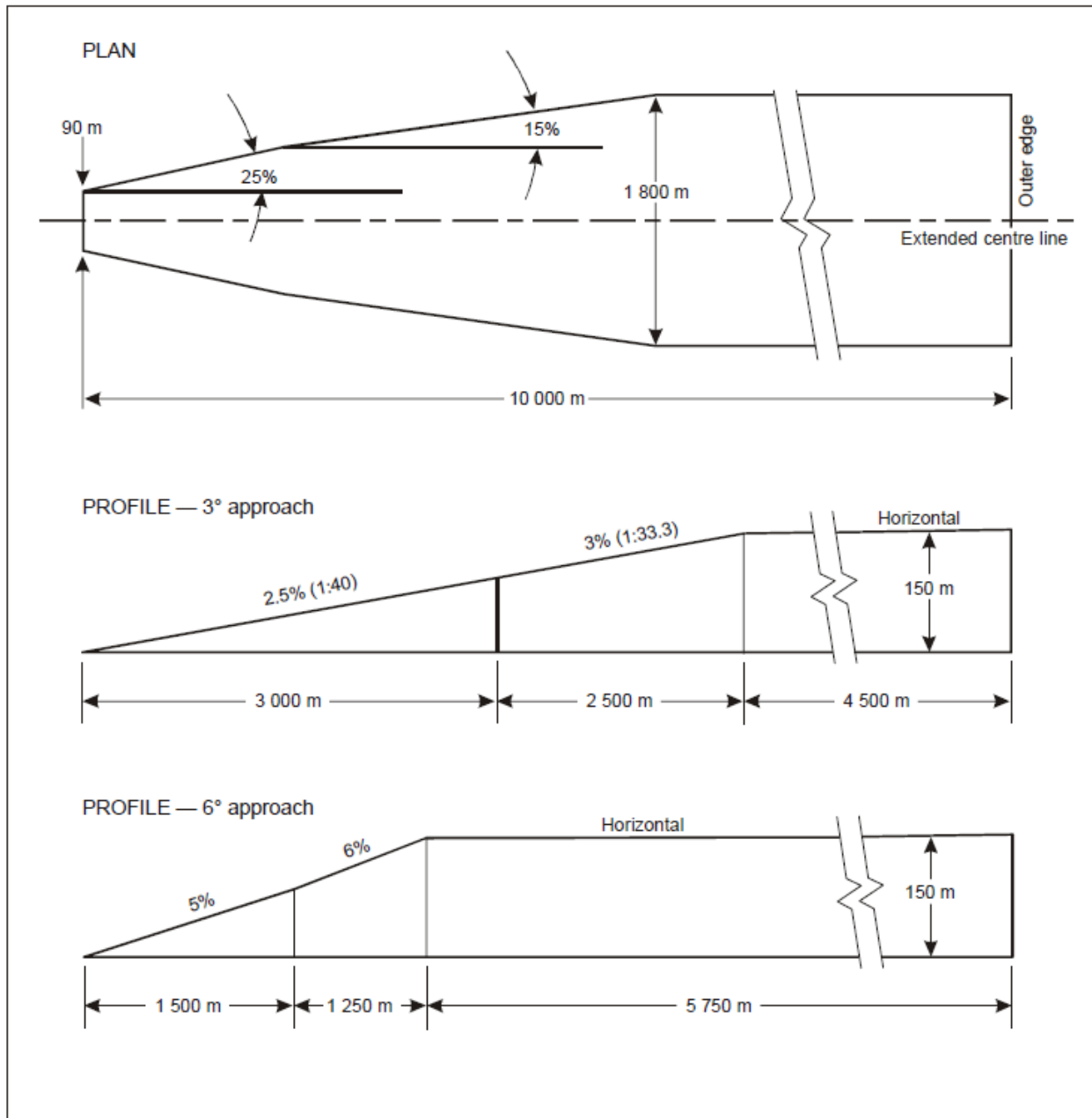

Figure A4-2. Approach surface for Precision Approach FATO

Editorial Note.— This is existing Figure 4-7 relocated to Appendix 2.

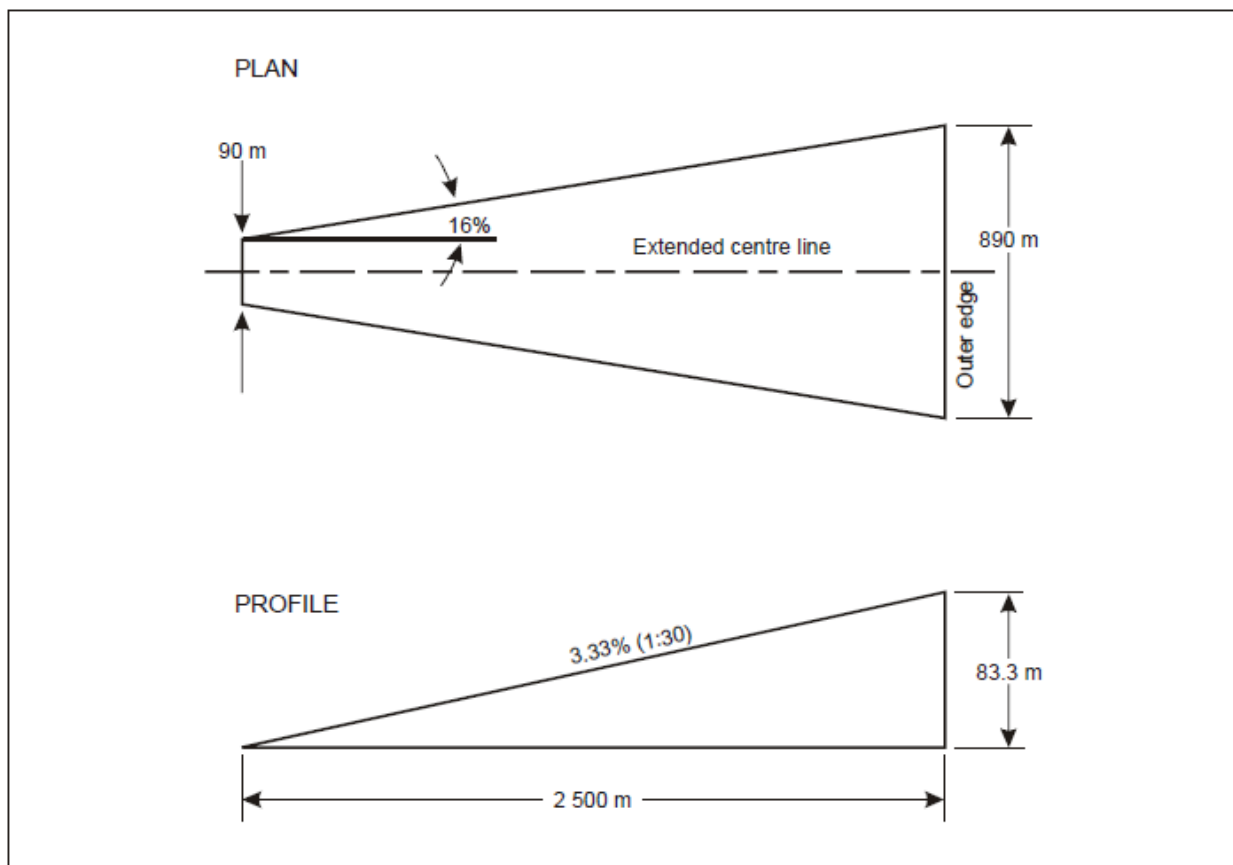

Figure A4-3. Approach surface for Non-precision Approach FATO

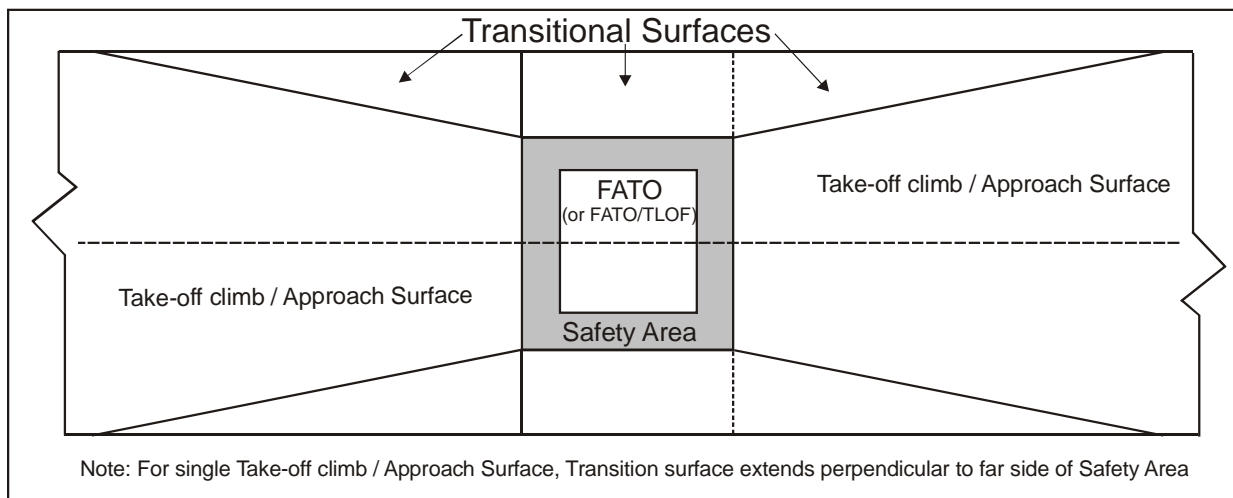

Figure A4-4 Transitional Surfaces for an instrument FATO with a non-precision and/or precision approach

4.2.2 The slopes of the obstacle limitation surfaces shall not be greater than, and their other dimensions not less than, those specified in Tables A4-1 to A4-3.

Table A4-1. Dimensions and slopes of Obstacle Limitation Surfaces

Instrument (Non-precision) FATO

Surface and dimensions		
APPROACH SURFACE		
Width of inner edge		Width of safety area
Location of inner edge		Boundary
<i>First section</i>		
Divergence	— day	16%
	— night	
Length	— day	2 500 m
	— night	
Outer width	— day	890 m
	— night	
Slope (maximum)		3.33%
<i>Second section</i>		
Divergence	— day	—
	— night	
Length	— day	—
	— night	
Outer width	— day	—
	— night	
Slope (maximum)		—
<i>Third section</i>		
Divergence		—
Length	— day	—
	— night	
Outer width	— day	—
	— night	
Slope (maximum)		—
TRANSITIONAL		
Slope		20%
Height		45 m

Table A4-3. Dimensions and slopes of Obstacle Limitation Surfaces**STRAIGHT TAKE-OFF**

Surface and dimensions		Instrument
TAKE-OFF CLIMB		
Width of inner edge		90 m
Location of inner edge		Boundary or end of clearway
<i>First section</i>		
Divergence	— day	30%
	— night	
Length	— day	2 850 m
	— night	
Outer width	— day	1 800 m
	— night	
Slope (maximum)		3.5%
<i>Second section</i>		
Divergence	— day	parallel
	— night	
Length	— day	1 510 m
	— night	
Outer width	— day	1 800 m
	— night	
Slope (maximum)		3.5%*
<i>Third section</i>		
Divergence		parallel
Length	— day	7 640 m
	— night	
Outer width	— day	1 800 m
	— night	
Slope (maximum)		2%

* This slope exceeds the maximum mass one-engine-inoperative climb gradient of many helicopters which are currently operating.

CHAPTER 5. VISUAL AIDS**5.3 Lights****5.3.3 Approach Lighting Systems**

5.3.3.1 Recommendation.— *Where an approach lighting system is provided for a non-precision FATO, the system should not be less than 210 m in length.*

5.3.3.2 Recommendation.— *The light distribution of steady lights should be as indicated in Figure 5-11, Illustration 2 except that the intensity should be increased by a factor of 3 for a non-precision FATO.*

Table A5-1. Dimensions and slopes of the obstacle protection surface

SURFACE AND DIMENSIONS	NON-PRECISION FATO	
Length of inner edge	Width of safety area	
Distance from end of FATO	60 m	
Divergence	15%	
Total length	2 500 m	
Slope	PAPI	A ^a - 0.57°
	HAPI	A ^b - 0.65°
	APAPI	A ^a - 0.9°
a.As indicated in Annex 14, Volume I, Figure 5-19.		
b.The angle of the upper boundary of the “below slope” signal.		

Rationale

Although PinS approaches (with or without a visual segment) are the most common means of instrument approach to a (visual) heliport, there are still some examples of instrument (non-precision or precision) heliports and some states have indicated that future instrument (non-precision or precision) heliports may be built. As a result, non-precision and precision heliport has been retained for future review and revision, however to provide for better flow of the document, this section has been moved to an appendix.

...

ATTACHMENT B to State letter AN 4/1.1.51-11/31

RESPONSE FORM TO BE COMPLETED AND RETURNED TO ICAO TOGETHER WITH ANY COMMENTS YOU MAY HAVE ON THE PROPOSED AMENDMENTS

To: The Secretary General
International Civil Aviation Organization
999 University Street
Montréal, Quebec
Canada, H3C 5H7

(State) _____

Please make a checkmark (✓) against one option for each amendment. If you choose options “agreement with comments” or “disagreement with comments”, **please provide your comments on separate sheets.**

	<i>Agreement without comments</i>	<i>Agreement with comments*</i>	<i>Disagreement without comments</i>	<i>Disagreement with comments</i>	<i>No position</i>
Amendment to Annex 14, Volume II – <i>Heliports</i> (Attachment A refers)					

*“Agreement with comments” indicates that your State or organization agrees with the intent and overall thrust of the amendment proposal; the comments themselves may include, as necessary, your reservations concerning certain parts of the proposal and/or offer an alternative proposal in this regard.

Signature: _____ Date: _____

— END —



International
Civil Aviation
Organization

Organisation
de l'aviation civile
internationale

Organización
de Aviación Civil
Internacional

Международная
организация
гражданской
авиации

منظمة الطيران
المدني الدولي

国际民用
航空组织

Tel.: +1 (514) 954-6717

Ref.: AN 4/1.1.52-11/41

30 May 2011

Subject: Proposal for the amendment of Annex 14,
Volume I, Annex 15 and PANS-ATM (Doc 4444)

Action required: Comments to reach Montréal by
15 September 2011

Sir/Madam,

1. I have the honour to inform you that the Air Navigation Commission, at the first meeting of its 187th Session on 3 May 2011, considered the proposals developed by the second meeting of the Aerodromes Panel (AP) to amend the SARPs in Annex 14, Volume I – *Aerodrome Design and Operations*, Annex 15 – *Aeronautical Information Services*, and *Procedures for Air Navigation Services – Air Traffic Management* (PANS-ATM, Doc 4444) relating to design and operations of aerodromes, SNOWTAM format and ATC phraseologies, and authorized their transmission to Contracting States and appropriate international organizations for comments.

2. To facilitate your review of the proposed amendment, the rationale for the proposal has been provided throughout Attachments A, B and C in the text boxes immediately following the relevant proposals. Also provided in Attachment D is the draft guidance material on RESA and associated mitigating measures, including arresting systems, to further assist you in the review of the proposed SARPs in this respect. This guidance material is intended for inclusion in the *Aerodrome Design Manual*, Part 1 — *Runways* (Doc 9157) after the proposed SARPs become applicable.

3. The amendment proposals to Annex 14, Volume I include, *inter alia* amendments in regard to maximum allowable tire pressure category in the reporting of strength of pavements; runway surface friction measurement and reporting; runway end safety areas (RESA) and arresting systems; strength of blast pads; visual aids for navigation, including simple touchdown zone lights, enhanced taxiway centre line marking, stop bars, runway guard lights (RGLs) and obstacle lighting; rescue and fire fighting (RFF); including performance level C foam; siting of equipment and installations on operational areas and aerodrome maintenance.

4. The proposed amendments to Annex 15 relates to SNOWTAM format concerning runway surface conditions, including friction characteristics. And the amendment proposal to PANS-ATM covers ATC phraseologies with respect to runway surface condition and aircraft braking action.

5. In examining the proposed amendment, you should not feel obliged to comment on editorial aspects as such matters will be addressed by the Air Navigation Commission during its final review of the draft amendment.

6. May I request that any comments you may wish to make on the proposed amendments to Annex 14, Volume I, Annex 15, and PANS-ATM be dispatched to reach me not later than 15 September 2011. The Air Navigation Commission has asked me to specifically indicate that comments received after the due date may not be considered by the Commission and the Council. In this connection, should you anticipate a delay in the receipt of your reply, please let me know in advance of the due date.

7. For your information, the proposed amendment to Annex 14, Volume I is envisaged for applicability on 15 November 2012, to Annex 15 on 14 November 2013 and to PANS-ATM on 13 November 2014. Any comments you may have thereon would be appreciated.

8. The subsequent work of the Air Navigation Commission and the Council would be greatly facilitated by specific statements on the acceptability or otherwise of the amendment proposal.

9. Please note that, for the review of your comments by the Air Navigation Commission and the Council, replies are normally classified as “agreement with or without comments”, “disagreement with or without comments”, or “no indication of position”. If in your reply the expressions “no objections” or “no comments” are used, they will be taken to mean “agreement without comment” and “no indication of position”, respectively. In order to facilitate proper classification of your response, a form has been included in Attachment E, which may be completed and returned together with your comments, if any, on the proposals in Attachments A, B and C.

Accept, Sir/Madam, the assurances of my highest consideration.



Raymond Benjamin
Secretary General

Enclosures:

- A— Proposed amendment to Annex 14, Volume I
- B— Proposed amendment to Annex 15
- C— Proposed amendment to PANS-ATM (Doc 4444)
- D— Guidance material on RESA and associated mitigating measures
- E - Response Form

ATTACHMENT A to State letter AN 4/1.1.52-11/41

PROPOSED AMENDMENT TO THE

**INTERNATIONAL STANDARDS
AND RECOMMENDED PRACTICES**

AERODROME DESIGN AND OPERATIONS

ANNEX 14, VOLUME I

TO THE CONVENTION ON INTERNATIONAL CIVIL AVIATION

**NOTES ON THE PRESENTATION OF THE PROPOSED AMENDMENT TO ANNEX 14,
VOLUME I**

The text of the amendment is arranged to show deleted text with a line through it and new text highlighted with grey shading, as shown below:

1. ~~Text to be deleted is shown with a line through it.~~ text to be deleted
2. **New text to be inserted is highlighted with grey shading.** new text to be inserted
3. ~~Text to be deleted is shown with a line through it~~ followed by the replacement text which is **highlighted with grey shading.** new text to replace existing text

CHAPTER 1. GENERAL

...

1.1 Definitions

...

Runway end safety area (RESA). An area symmetrical about the extended runway centre line and adjacent to the end of the strip primarily intended to reduce the risk of damage to an aeroplane undershooting or overrunning the runway, and also to allow an aeroplane overrunning to decelerate and an aeroplane undershooting to continue its approach or landing.

...

CHAPTER 2. AERODROME DATA

...

2.6 Strength of pavements

...

2.6.6 Information on pavement type for ACN-PCN determination, subgrade strength category, maximum allowable tire pressure category and evaluation method shall be reported using the following codes:

...

c) *Maximum allowable tire pressure category:*

	<i>Code</i>
High Unlimited : no pressure limit	W
Medium High : pressure limited to 1.50 1.75 MPa	X
Low Medium : pressure limited to 1.00 1.25 MPa	Y
Very Low : pressure limited to 0.50 MPa	Z

Note.— See Note 5 to 10.2.1 where the pavement is used by aircraft with high tire pressures.

d) *Evaluation method:*

Code

Technical evaluation: representing a specific study of the pavement characteristics and application of pavement behaviour technology. T

Using aircraft experience: representing a knowledge of the specific type and mass of aircraft satisfactorily being supported under regular use. U

Note.— The following examples illustrate how pavement strength data are reported under the ACN-PCN method.

Example 1.— If the bearing strength of a rigid pavement, resting on a medium strength subgrade, has been assessed by technical evaluation to be PCN 80 and there is no tire pressure limitation, then the reported information would be:

PCN 80 / R / B / W / T

Example 2.— If the bearing strength of a composite pavement, behaving like a flexible pavement and resting on a high strength subgrade, has been assessed by using aircraft experience to be PCN 50 and the maximum tire pressure allowable is 1.0025 MPa, then the reported information would be:

PCN 50 / F / A / Y / U

Note.— Composite construction

Example 3.— If the bearing strength of a flexible pavement, resting on a medium strength subgrade, has been assessed by technical evaluation to be PCN 40 and the maximum allowable tire pressure is 0.80 MPa, then the reported information would be:

PCN 40 / F / B / 0.80 MPa / T

Example 4.— If a pavement is subject to a B747-400 all-up mass limitation of 390 000 kg, then the reported information would include the following note.

Note.— The reported PCN is subject to a B747-400 all-up mass limitation of 390 000 kg.

Rationale

In 1978, ICAO initiated the adoption of a single means for airports to express the load bearing capacity of airfield pavement, and at the same time, created a means by which the aircraft manufacturers could indicate the pavement loading intensity of their aircraft. The method is now used worldwide, and is referred to as the ACN/PCN System. There are five attributes to the ACN/PCN system: pavement type,

subgrade code, allowable tire pressure, description of the method by which the pavement rating was developed and numerical PCN (and ACN) value.

From the advent of this system, the tire pressure element was and remains only loosely defined, having no ICAO prescribed methodology. The dilemma that is facing both airports and aircraft manufacturers is that commercial aircraft tire pressures have gradually increased, and yet few if any known pavement failures have come to light, therefore indicating that the tire pressure limits that have been part of the ACN/PCN system ever since its inception could possibly be increased somewhat without putting airfield pavements or aircraft at risk. This has been substantiated by the results of two series of full-scale testing in France and in the United States and by the analysis of a survey by ACI. The proposed amendment is intended to facilitate the use of aircraft with higher tyre pressure which would have a beneficial impact on costs, environment and to a lesser degree, safety of operations.

...

CHAPTER 2. AERODROME DATA

...

2.9 Condition of the movement area and related facilities

2.9.1 Information on the condition of the movement area and the operational status of related facilities shall be provided to the appropriate aeronautical information services units, and similar information of operational significance to the air traffic services units, to enable those units to provide the necessary information to arriving and departing aircraft. The information shall be kept up to date and changes in conditions reported without delay.

Note.— Nature, format and conditions of the information to be provided are specified in Annex 15 and PANS-ATM (Doc 4444).

2.9.2 The condition of the movement area and the operational status of related facilities shall be monitored and reports on matters of operational significance or affecting aircraft ~~performance given~~ and aerodrome operations shall be provided in order to take appropriate action, particularly in respect of the following:

- a) construction or maintenance work;
- b) rough or broken surfaces on a runway, a taxiway or an apron;
- c) snow, slush, ~~or~~ ice, wet ~~ice, wet snow on ice~~ or frost on a runway, a taxiway or an apron;
- d) water on a runway, a taxiway or an apron;
- e) snow banks or drifts adjacent to a runway, a taxiway or an apron;

- f) anti-icing or de-icing liquid chemicals or other contaminants on a runway, ~~or a taxiway~~ or apron;
- g) other temporary hazards, including parked aircraft;
- h) failure or irregular operation of part or all of the aerodrome visual aids; and
- i) failure of the normal or secondary power supply.

Note 1.— Other contaminants may include mud, dust, sand, volcanic ash, oil and rubber. Annex 6, Part 1, Attachment C provides guidance on the description of runway surface conditions. Additional guidance is included in the Airport Services Manual (Doc 9137), Part 2.

Note 2. — Particular attention may be given to the simultaneous presence of snow, slush, ice, wet ice, wet snow on ice with anti-icing or de-icing liquid chemicals.

Rationale

The above proposal seeks to clarify the purpose of reporting information on the movement area. Paragraph 2.9.1 addresses the need to inform the pilots while paragraph 2.9.2 relates to the initiation of appropriate maintenance actions or operational procedures at the aerodrome to prevent or mitigate potential hazards. The list of contaminants that can affect aircraft performance have been expanded to include references to relevant documents.

2.9.3 To facilitate compliance with 2.9.1 and 2.9.2, inspections of the movement area shall be carried out each day at least once where the code number is 1 or 2 and at least twice where the code number is 3 or 4.

Note.— Guidance on carrying out daily inspections of the movement area is given in the Airport Services Manual (Doc 9137), Part 8 and in the Manual of Surface Movement Guidance and Control Systems (SMGCS) (Doc 9476).

2.9.3A Recommendation.— *Personnel assessing and reporting runway surface conditions required in 2.9. 2 and 2.9.7 should be trained and competent to meet criteria set by the State.*

Note.— Guidance on criteria is included in the Airport Services Manual (Doc 9137), Part 8, Chapter 7.

Rationale

The above proposal introduces the need for personnel involved in the runway surface condition assessment and reporting to have the skills necessary to ensure the quality and accuracy of information reported for maintenance and operational purposes.

Water on a runway

2.9.4 **Recommendation.**— *Whenever water is present on a runway, a description of the runway surface conditions ~~on the centre half of the width of the runway, including the possible assessment of water depth, where applicable,~~ should be made available using the following terms:*

~~*DAMP* — the surface shows a change of colour due to moisture.~~

WET — the surface is soaked but there is no standing water.

~~*WATER PATCHES* — significant patches of standing water are visible.~~

~~*FLOODED* — extensive standing water is visible.~~

STANDING WATER — for aeroplane performance purposes, a runway where more than 25 per cent of the runway surface area (whether in isolated areas or not) within the required length and width being used is covered by water more than 3 mm deep.

Rationale

Proposed amendment to the above paragraph seeks to align the existing definitions with those in Annex 6, Part 1, Amendment 33A. In general, terms not reflecting operational needs are proposed to be deleted.

The term *DAMP* is proposed to be removed following changes to Annex 6, Part 1, Attachment C, Section 2. Definitions, which defines the state of the runway surface as either dry, wet or contaminated. A *DAMP* surface should be considered *WET* and the term *DAMP* removed from the information reported in SNOWTAM and through ATC. This is in line with changes in harmonized US/European specification criteria and underlying documentation. However, the FTF is aware of the use of the term *DAMP* in EU regulation for aircraft operations, and that there are interests in retaining the term.

The term *WATER PATCHES* is considered to be of no practical value and is proposed for deletion. Also, the FTF is aware that the term *FLOODED* is rarely reported and is therefore proposed to be replaced by the term *STANDING WATER*.

2.9.5 Information that a runway or portion thereof may be slippery when wet shall be made available.

2.9.6 ~~A~~ **When a paved runway or portion thereof does not meet shall be determined as being slippery when wet when the measurements the requirements specified in 10.2.3, notification shall be issued to aerodrome users in a manner show that the runway surface friction characteristics as measured by a continuous friction measuring device are below the minimum friction level specified by the State.**

Note.— *Guidance on conducting a runway surface friction characteristics evaluation programme that includes determining and expressing the minimum friction level is provided in Attachment A, Section 7.*

~~2.9.7 Information on the minimum friction level specified by the State for reporting slippery runway conditions and the type of friction measuring device used shall be made available.~~

~~2.9.8 **Recommendation.**— When it is suspected that a runway may become slippery under unusual conditions, then additional measurements should be made when such conditions occur, and information on the runway surface friction characteristics made available when these additional measurements show that the runway or a portion thereof has become slippery.~~

Rationale

The above amendments aim at making a clear distinction between the assessment of runway surface friction characteristics for maintenance purpose and the evaluation for operational purpose. For maintenance purpose, the prime criterion is the Minimum Friction Level (MFL) below which notification shall be issued to aerodrome users.

For the purpose of operations, the prime parameter is the estimated surface friction which is estimated on the basis of the assessments made for maintenance, the actual state of the runway, the weather conditions, and other criteria. The estimated surface friction is communicated, in compliance with existing paragraph 2.9.1, to pilots and aircraft operators through SNOWTAM.

Existing paragraph 2.9.7 is proposed to be deleted because a determination of the surface to be slippery does not rest solely with friction levels as measured with a measuring device. The notion of relying only on friction measurement should be replaced by the notion of runway surface condition assessment and estimated surface friction. Furthermore, as each aerodrome operator can use a friction measuring device provided its performance meet the standard and correlation criteria set or agreed by the State (see new paragraph 2.9.8 below), this device may differ from the one which the State may use as a reference or for its own inspections. The promulgation of this information is misleading and has proven to be a contributing factor to accidents. The proposed deletion of existing paragraph 2.9.7 requires a consequential amendment to Annex 15.

Existing paragraph 2.9.8 is proposed to be deleted to avoid being interpreted as a recommendation for assessment for operational use. Friction measurements are to be used primarily for maintenance purpose according to a maintenance programme taking into account unusual conditions; however, they can be used for operational evaluation under defined conditions according to different operational procedures. Additional guidance will be provided in Annex 14, Vol. I, Attachment A (green pages), sections 6 and 7.

Snow, slush, ~~or~~ ice or frost on a runway

Note 1.— *The intent of these specifications is to satisfy the SNOWTAM and NOTAM promulgation requirements contained in Annex 15.*

Note 2.— Runway surface condition sensors may be used to detect and continuously display current or predicted information on surface conditions such as the presence of moisture, or imminent formation of ice on pavements.

2.9.97 Recommendation.— Whenever an operational runway is affected contaminated by snow, slush, or ice, or frost, and it has not been possible to clear the precipitant fully, the condition of the runway surface condition should shall be assessed, and the friction coefficient measured reported.

Note.— Guidance on determining and expressing the friction characteristics assessment of snow- and ice-covered paved surfaces is provided in Attachment A, Section 6.

2.9.7A Recommendation. —Runway surface friction measurements made on a runway that is contaminated by slush, wet snow or wet ice should not be reported.

Note.—Contaminant drag on the equipment’s measuring wheel, amongst other factors, may cause readings obtained in these conditions to be unreliable.

2.9.108 Recommendation.— When friction measurements are taken as part of the assessment, ~~The readings performance of the friction measuring device on compacted snow, slush, or ice-covered surfaces should adequately correlate with the readings of one other such device~~ meet the standard and correlation criteria set or agreed by the State.

Note.— The principal aim is to measure surface friction in a manner that is relevant to the friction experienced by an aircraft tire, thereby providing correlation between the friction measuring device and aircraft braking performance. Guidance on criteria for, and correlation between, friction measuring devices is included in the Airport Services Manual (Doc 9137), Part 2.

Rationale:

The amendment proposed in existing paragraph 2.9.9 (renumbered 2.9.7) seeks to require that the runway surface condition is assessed and reported when affected by snow, slush, ice or frost.

Proposed amendment to existing paragraph 2.9.10 (renumbered 2.9,8) requires that friction measurement devices meet the standards set by the State when they are used for the assessment of the runway surface condition in order to ensure the quality and accuracy of the information reported. This provision is complementary with the requirements proposed in the new paragraph 2.9.3A.

2.9.9 Recommendation.— Whenever snow, slush, ice or frost is present and reported, the description of the runway surface condition should use the following terms:

DRY SNOW;

WET SNOW;

COMPACTED SNOW;

WET COMPACTED SNOW;

SLUSH;

ICE;

WET ICE;

FROST;

DRY SNOW ON ICE;

WET SNOW ON ICE;

CHEMICALLY TREATED.

SANDED.

and should include, where applicable, the assessment of contaminant depth.

Rationale

The Recommendation proposed in the new paragraph 2.9.9 makes a clear linkage to the operational use of the information through the reporting format (see also proposed amendments to existing paragraphs 2.9.2 and 2.9.4) and is harmonized, to the extent possible, with the SNOWTAM format in Annex 15.

....

CHAPTER 3. PHYSICAL CHARACTERISTICS

3.1 Runways

....

Surface of runways

3.1.22 The surface of a runway shall be constructed without irregularities that would ~~result in loss in~~ impair the runway surface friction characteristics or otherwise adversely affect the take-off or landing of an aeroplane.

Note 1.— Surface irregularities may adversely affect the take-off or landing of an aeroplane by causing excessive bouncing, pitching, vibration, or other difficulties in the control of an aeroplane.

Note 2.— Guidance on design tolerances and other information is given in Attachment A, Section 5. Additional guidance is included in the Aerodrome Design Manual (Doc 9157), Part 3.

3.1.23 ~~The surface of a~~ A paved runway shall be so constructed or resurfaced as to provide good surface friction characteristics ~~when the runway is wet~~ at or above the minimum friction level set by the State.

3.1.23A **Recommendation.**— *The surface of a paved runway should be evaluated when constructed or resurfaced to determine that the surface friction characteristics achieve the design objectives.*

Note.— *Guidance on surface friction characteristics of a new or resurfaced runway is given in Attachment A, Section 7. Additional guidance is included in the Airport Services Manual, Part 2.*

3.1.24 **Recommendation.**— *Measurements of the surface friction characteristics of a new or resurfaced runway should be made with a continuous friction measuring device using self-wetting features ~~in order to assure that the design objectives with respect to its friction characteristics have been achieved.~~*

Note.— *Guidance on surface friction characteristics of new runway surfaces is given in Attachment A, Section 7. Additional guidance is included in the Airport Services Manual (Doc 9137), Part 2.*

3.1.25 **Recommendation.**— *The average surface texture depth of a new surface should be not less than 1.0 mm.*

Note 1.— *Macrottexture and microtexture are taken into consideration in order to provide the required surface friction characteristics. This normally requires some form of special surface treatment. Guidance on surface design is given in Attachment A, Section 8.*

Note 2.— *Guidance on methods used to measure surface texture is given in the Airport Services Manual (Doc 9137), Part 2.*

Note 3.— *Guidance on design and methods for improving surface texture is given in the Aerodrome Design Manual (Doc 9157), Part 3.*

3.1.26 **Recommendation.**— *When the surface is grooved or scored, the grooves or scorings should be either perpendicular to the runway centre line or parallel to non-perpendicular transverse joints, where applicable.*

Note.— *Guidance on methods for improving the runway surface texture is given in the Aerodrome Design Manual (Doc 9157), Part 3.*

...

Rationale

The amendments proposed seek to replace an ambiguous objective in existing paragraph 3.1.23 with a quantifiable level established by the regulator. The availability of appropriate guidance to assist the State, in this regard, is provided in the associated Notes.

The importance of micro- and macro-texture, and its contribution towards surface friction characteristics is highlighted, with appropriate guidance referred to in the notes to existing paragraph 3.1.25.

3.2 Runway shoulders

...

3.2.5 **Recommendation.**— *A runway shoulder should be prepared or constructed so as to be capable, in the event of an aeroplane running off the runway, of supporting the aeroplane without inducing structural damage to the aeroplane and of supporting ground vehicles which may operate on the shoulder.*

Note.— *Guidance on strength of runway shoulders is given in the Aerodrome Design Manual (Doc 9157), Part 1.*

...

3.3 Runway turn pads

....

Surface of runway turn pads

3.3.10 The surface of a runway turn pad shall not have surface irregularities that may cause damage to an aeroplane using the turn pad.

3.3.11 **Recommendation.**— *The surface of a runway turn pad should be so constructed or resurfaced as to provide ~~good~~ suitable surface friction characteristics. ~~for aeroplanes using the facility when the surface is wet.~~*

...

3.4 Runway strips

...

Objects on runway strips

Note.— *See 9.9 for information regarding siting of equipment and installations on runway strips.*

3.4.6 **Recommendation.**— *An object situated on a runway strip which may endanger aeroplanes should be regarded as an obstacle and should, as far as practicable, be removed.*

3.4.7 No fixed object, other than visual aids required for air navigation or those required for aircraft safety purposes and which must be sited on the runway strip, purposes and satisfying the relevant frangibility requirement in Chapter 5, shall be permitted on a runway strip:

...

3.4.11 **Recommendation.**— *That portion of a strip to at least 30 m before a threshold should be prepared against blast erosion in order to protect a landing aeroplane from the danger of an exposed edge.*

3.4.12 **Recommendation.**— *Where the areas in 3.4.11 have paved surfaces, they should be able to withstand the occasional passage of the critical aeroplane for runway pavement design.*

Note. — *The area adjacent to the end of a runway may be referred to as a blast pad.*

Editorial Note.— Re-number the subsequent paragraphs accordingly.

Rationale

The intent of the proposed changes to paragraph 3.4.7 is to allow the installation of arresting systems which are frangible and intended to enhance safety in the event of an aircraft overrun.

The proposed new paragraph 3.4.12 is in response to safety recommendations arising from States' investigations into aircraft accidents/incidents, one of which involved the provision of blast pads at the end of runways. It is recognized that Annex 14, Volume I does not currently address blast pads and that design and strength requirements for them would be required. There is a need to differentiate the runway ends from the runway shoulders and to identify the areas before the runway ends as blast pads, if provided. The strength specifications should be consistent with those for runway shoulders.

...

3.5 Runway end safety areas

General

3.5.1 A runway end safety area shall be provided at each end of a runway strip where:

— the code number is 3 or 4; and

— the code number is 1 or 2 and the runway is an instrument one.

Note.— *Guidance on runway end safety areas is given in Attachment A, Section 9.*

3.5.2 Recommendation.— *A runway end safety area should be provided at each end of a runway strip where the code number is 1 or 2 and the runway is a non-instrument one.*

Dimensions of runway end safety areas

3.5.223 A runway end safety area shall extend from the end of a runway strip to a distance of at least 90 m where:

- the code number is 3 or 4; and
- the code number is 1 or 2 and the runway is an instrument one.

3.5.34 Recommendation.— *A runway end safety area should, as far as practicable, extend from the end of a runway strip to a distance of at least:*

- a) 240 m where the code number is 3 or 4; ~~and~~
- b) 120 m where the code number is 1 or 2 *and the runway is an instrument one; and*
- c) 30 m where the code number is 1 or 2 *and the runway is a non-instrument one.*

3.5.5 Notwithstanding the provisions in 3.5.3 and 3.5.4 a) and b), the length of a runway end safety area may be reduced where an arresting system is installed with demonstrated performance that provides a level of protection at least equivalent to the prescribed runway end safety area.

Note. — *Guidance on arresting systems is given in Attachment A, Section 9.*

3.5.456 The width of a runway end safety area shall be at least twice that of the associated runway.

Editorial Note.— Re-number subsequent paragraphs accordingly.

Rationale

The proposed Recommended Practice in paragraph 3.5.2 arises from aircraft overrun data demonstrating that based on studies carried out in some States, the risk from overruns is also present for visual runways; accordingly, requirements for RESA should be introduced.

Paragraph 3.5.4 Clarifies the recommended practice distances for those runways already requiring RESAs, and for non-instrument runways. The distance for non-instrument runways arises from distances already implemented in some States. It is noted that the landing dispersion for non-instrument runways justifies a need to include minimum distances and that certain distances have been implemented in the USA (42m) and the Netherlands (60m). Therefore, a distance of 30 m is proposed

as the starting point, with a review as future studies are made available.

Research programmes, as well as evaluation of actual aircraft overruns into arresting systems have demonstrated that the performance of some arresting systems are predictable and effective in arresting aircraft overruns. The proposed paragraph 3.5.5 is intended to introduce the use of an arresting system with demonstrated performance, in relation to the provision of RESA, to help mitigate the consequences of an aircraft overrun.

3.7 Stopways

...

Surface of stopways

3.7.4 **Recommendation.**— The surface of a *paved* stopway ~~should~~ shall be so constructed or resurfaced as to provide ~~a good coefficient of surface friction characteristics to be compatible with that~~ at or above those of the associated runway ~~when the stopway is wet.~~

~~3.7.5 **Recommendation.**— The friction characteristics of an unpaved stopway should not be substantially less than that of the runway with which the stopway is associated.~~

...

3.9 Taxiways

...

Surface of taxiways

3.9.14 **Recommendation.**— *The surface of a taxiway should not have irregularities that cause damage to aeroplane structures.*

3.9.15 **Recommendation.**— The surface of a *paved* taxiway should be so constructed or resurfaced as to provide ~~good~~ suitable surface friction characteristics ~~when the taxiway is wet.~~

...

Rationale

Proposed amendments to paragraphs 3.3.11, 3.7.4 and 3.9.15 require the provision of suitable friction characteristics under wet and other conditions when designing and constructing pavement surfaces.

...

CHAPTER 5. VISUAL AIDS FOR NAVIGATION

5.2.8 Taxiway centre line marking

...

5.2.8.5 Where provided, enhanced taxiway centre line marking shall be installed at ~~all~~ **each** taxiway/runway intersections ~~at that aerodrome.~~

...

~~5.2.8.9 Where provided, an enhanced taxiway centre line marking shall extend from the runway holding position pattern A (as defined in Figure 5-6, Taxiway markings) to a distance of up to 45m (a minimum of three (3) dashed lines) in the direction of travel away from the runway or to the next runway holding position, if within 45m distance.~~

5.2.8.9 Where provided:

(1) An enhanced taxiway centre line marking shall extend from the runway-holding position Pattern A (as defined in Figure 5-6, Taxiway markings) to a distance of up to 47m in the direction of travel away from the runway. See Figure 5-7(a).

(2) If the enhanced taxiway centre line marking intersects another runway-holding position marking, such as for a precision approach category II or III runway, that is located within 47m of the first runway-holding position marking, the enhanced taxiway centre line marking shall be interrupted 0.9m prior to and after the intersected runway-holding position marking. The enhanced taxiway centre line marking shall continue beyond the intersected runway-holding position marking for at least 3 dashed line segments or 47m from start to finish, whichever is greater. See Figure 5-7(b).

(3) If the enhanced taxiway centre line marking continues through a taxiway/taxiway intersection that is located within 47m of the runway-holding position marking, the enhanced taxiway centre line marking shall be interrupted 1.5m prior to and after the point where the intersected taxiway centre line crosses the enhanced taxiway centre line. The enhanced taxiway centre line marking shall continue beyond the taxiway/taxiway intersection for at least 3 dashed line segments or 47m from start to finish, whichever is greater. See Figure 5-7(c).

(4) Where two taxiway centre lines converge at or before the runway-holding position marking, the inner dashed line shall not be less than 3m in length. See Figure 5-7(d).

(5) Where there are two opposing runway-holding position markings and the distance between the markings is less than 94m, the enhanced taxiway centre line markings shall extend over this entire distance. The enhanced taxiway centre line markings shall not extend beyond either runway-holding position marking. See Figure 5-7(e).

Editorial Note.— Replace existing Figure 5-7 with the following new Figure 5-7.

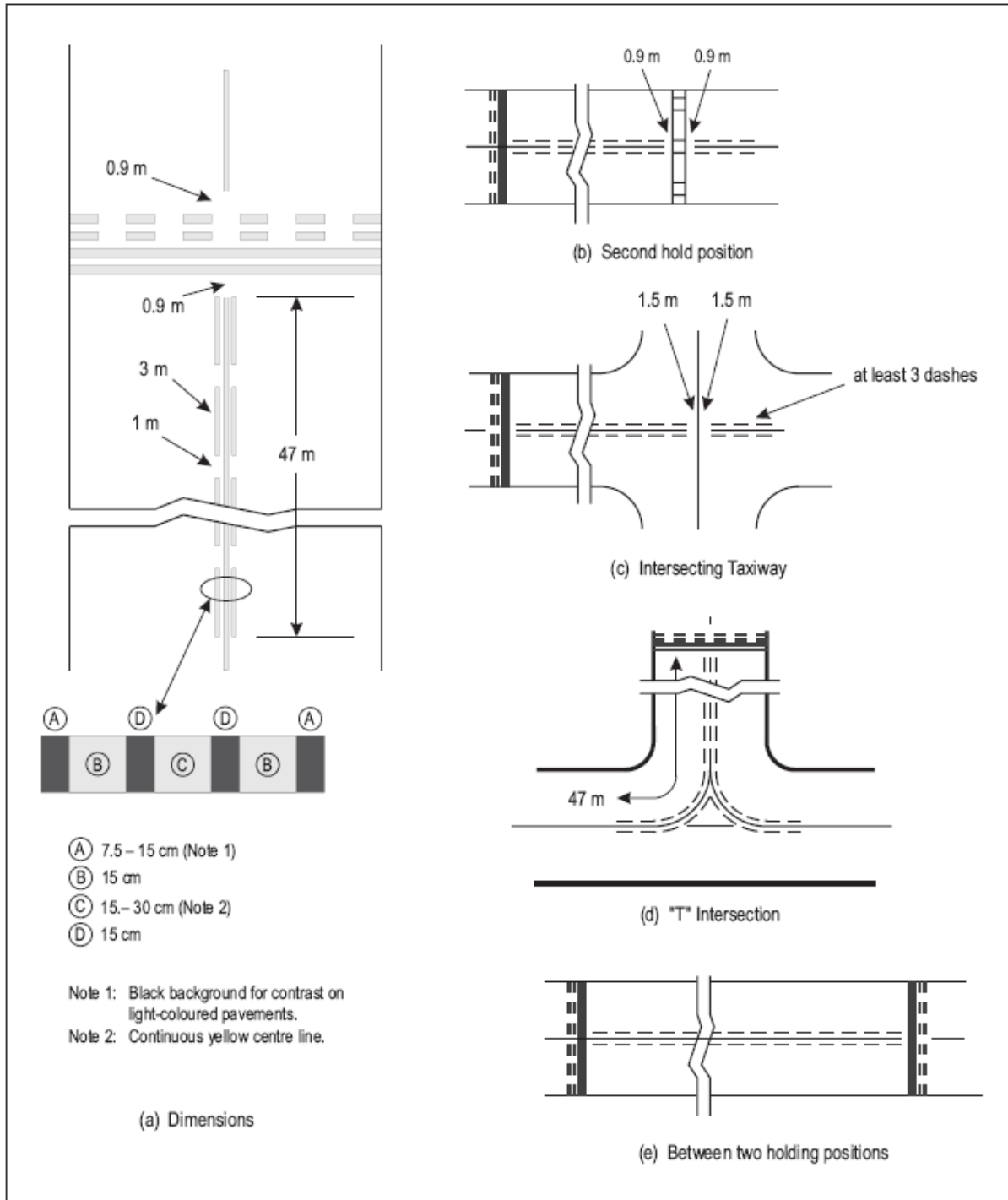

Figure 5-7. Enhanced Taxiway Centre Line Marking

Rationale

The purpose of this amendment is two-fold. Firstly there were errors in the original paper presented to and accepted by AP/1, in that the graphic did not represent the existing markings correctly. Additionally, the mathematics indicated an enhanced length of 47m where the graphic and description indicated 45m. Additional clarification on the graphic is added to the description in 5.2.8.9 (2-5). Figure 5-7 is corrected to show the proper markings.

...

5.3.13.7 Simple Touchdown Zone Lights

Note.— The purpose of Simple Touchdown Zone Lights is to provide pilots with enhanced situational awareness in all visibility conditions and to help enable pilots to decide whether to commence a go around if the aircraft has not landed by a certain point on the runway. It is essential that pilots operating at aerodromes with Simple Touchdown Zone Lights be familiar with the purpose of these lights.

Application

5.3.13.7.1 **Recommendation.**- *Except where TDZ lights are provided in accordance with paragraph 5.3.13, at an aerodrome where the approach angle is greater than 3.5 degrees and/or the Landing Distance Available combined with other factors increases the risk of an overrun, Simple Touchdown Zone Lights should be provided.*

Location

5.3.13.7.2 Simple Touchdown Zone Lights shall be located both sides of the runway centreline at the upwind edge of the final Touchdown Zone marking. The lateral spacing between the pair shall be equal to the lateral spacing selected for the touchdown zone marking.

5.3.13.7.3 **Recommendation.**- *Where provided on a runway without TDZ markings, Simple Touchdown Zone lights should be installed in such a position that provides the equivalent TDZ information.*

Characteristics

5.3.13.7.4 Simple Touchdown Zone Lights shall be fixed unidirectional lights showing variable white, aligned so as to be visible to the pilot of a landing aeroplane in the direction of approach to the runway.

5.3.13.7.5 Simple Touchdown Zone Lights shall be in accordance with the specifications in Appendix 2, Figure A2-5.

Note.— Simple Touchdown Zone Lights should be supplied with power on a separate independent switchable circuit to other runway lighting so that they may be used when other lighting is switched off.

Rationale

The installation of additional pairs of inset runway lights has been shown to help prevent runway excursions where a causal factor has been shown to be late touchdown of an aircraft beyond the TDZ markings.

...

5.3.16 Taxiway centre line lights

5.3.16.6 Except as provided for in 5.3.16.8, Taxiway centre line lights on a taxiway other than an exit taxiway and on a runway forming part of a standard taxi-route shall be fixed lights showing green with beam dimensions such that the light is visible only from aeroplanes on or in the vicinity of the taxiway.

5.3.16.7 Taxiway centre line lights on an exit taxiway shall be fixed lights. Alternate taxiway centre line lights shall show green and yellow from their beginning near the runway centre line to the perimeter of the ILS/MLS critical/sensitive area or the lower edge of the inner transitional surface, whichever is farthest from the runway; and thereafter all lights shall show green (Figure 5-25). The first light in the exit centre line shall always show green and the light nearest to the perimeter shall always show yellow. Where aircraft may follow the same centre line in both directions, all the centre line lights shall show green to aircraft approaching the runway.

5.3.16.8 **Recommendation.**— Where it is necessary to denote the proximity to a runway, taxiway centre line lights should be fixed lights showing alternating green and yellow from the perimeter of the ILS/MLS critical/sensitive area or the lower edge of the inner transitional surface, whichever is farthest from the runway, to the runway and continue alternating green and yellow until:

- a) their end point near the runway centre line; or
- b) in the case of the taxiway centre line lights crossing the runway, to the opposite perimeter of the ILS/MLS critical/sensitive area or the lower edge of the inner transitional surface, whichever is farthest from the runway.

Note 1.— Care is necessary to limit the light distribution of green lights on or near a runway so as to avoid possible confusion with threshold lights.

Note 2.— The provisions of 5.3.16.8 can form part of effective runway incursion prevention measures.

Editorial Note.— Re-number existing 5.3.16.8 to 5.3.16.9 and cascade the number changes (and all references) through the remainder of Section 5.3.16.

Rationale

This proposal seeks to add to the runway incursion reduction effort by matching the runway entrance taxiway lighting to the existing exit taxiway lighting (described in 5.3.16.7). Additionally, this matches the current FAA requirements for low visibility entrance taxiway lighting.

...

5.3.19 Stop bars

Application

Note 1.— *The provision of stop bars requires their control either manually or automatically by air traffic services.*

Note 2.— *Runway incursions may take place in all visibility or weather conditions. The provision of stop bars at runway holding positions and their use at night and in visibility conditions greater than 550 m runway visual range can form part of effective runway incursion prevention measures.*

5.3.19.1 A stop bar shall be provided at every runway-holding position serving a runway when it is intended that the runway will be used in runway visual range conditions less than a value of 350 m, except where:

a) appropriate aids and procedures are available to assist in preventing inadvertent incursions of aircraft and vehicles onto the runway; or

b) operational procedures exist to limit, in runway visual range conditions less than a value of 550 m, the number of:

1) aircraft on the manoeuvring area to one at a time; and

2) vehicles on the manoeuvring area to the essential minimum.

5.3.19.2 A stop bar shall be provided at every runway holding position, serving a runway when it is intended that the runway will be used in runway visual range conditions of values between 350 m and 550 m, except where:

a) appropriate aids and procedures are available to assist in preventing inadvertent incursions of aircraft and vehicles onto the runway; or

b) operational procedures exist to limit, in runway visual range conditions less than a value of 550 m, the

number of:

- 1) aircraft on the manoeuvring area to one at a time; and
- 2) vehicles on the manoeuvring area to the essential minimum.

5.3.19.3 Where there is more than one stop bar associated with a taxiway/runway intersection, only one shall be illuminated.

Rationale

Proposed 5.3.19.3 seeks to clarify the installation and use of stop bars in support of both low and normal visibility operations with respect to reducing the potential for runway incursions as well as reducing possible confusion when more than one runway holding position (RHP) is associated with an intersection. There have been cases where multiple stop bars have been illuminated at a single RHP leading to confusion on the part of crews as to their correct clearance limit.

5.3.19.34 **Recommendation.**— *A stop bar should be provided at an intermediate holding position when it is desired to supplement markings with lights and to provide traffic control by visual means.*

5.3.19.45 **Recommendation.**— *Where the normal stop bar lights might be obscured (from a pilot's view), for example, by snow or rain, or where a pilot may be required to stop the aircraft in a position so close to the lights that they are blocked from view by the structure of the aircraft, then a pair of elevated lights should be added to each end of the stop bar.*

5.3.19.6 **Recommendation.**— *A stop bar should be provided, where it is deemed necessary, as a no-entry bar across a taxiway which is intended to be used as an exit only taxiway to assist in preventing inadvertent access of vehicles or aircraft to that taxiway.*

Rationale

Proposed 5.3.19.6 introduces the application of stop bars in the use as a no-entry bar to prevent inadvertent access to a runway from a parallel taxiway on a connecting taxiway intended as an exit only taxiway.

Location

5.3.19.57 Stop bars shall be located across the taxiway at the point where it is desired that traffic stop. Where the additional lights specified in 5.3.19.45 are provided, these lights shall be located not less than 3 m from the taxiway edge.

Characteristics

5.3.19.68 Stop bars shall consist of lights spaced at uniform intervals of no more than 3m across the taxiway, showing red in the intended direction(s) of approach to the intersection or runway-holding position.

Note - Where necessary to enhance conspicuity of an existing stop bar, extra lights are installed uniformly.

Rationale

In regard to the proposed 5.3.19.8, field tests in a member State have demonstrated that increasing the overall number of lights in a stop bar by decreasing the space between individual lights increases the conspicuity of the stop bar while maintaining the consistency of the visual cue given flight crews and vehicle operators.

5.3.19.79 Stop bars installed at a runway-holding position shall be unidirectional and shall show red in the direction of approach to the runway.

5.3.19.810 Where the additional lights specified in 5.3.19.45 are provided, these lights shall have the same characteristics as the lights in the stop bar, but shall be visible to approaching aircraft up to the stop bar position.

~~5.3.19.9 Selectively switchable stop bars shall be installed in conjunction with at least three taxiway centre line lights (extending for a distance of at least 90 m from the stop bar) in the direction that it is intended for an aircraft to proceed from the stop bar.~~

Note. — See 5.3.16.12 for provisions concerning the spacing of taxiway centre line lights.

Rationale

5.3.19.9 is proposed for deletion and replaced with the combination of the new 5.3.19.3 and existing 5.3.19.13.c.

5.3.19.1011 The intensity in red light and beam spreads of stop bar lights shall be in accordance with the specifications in Appendix 2, Figures A2-12 through A2-16, as appropriate.

5.3.19.11 **12 Recommendation.**— *Where stop bars are specified as components of an advanced surface movement guidance and control system and where, from an operational point of view, higher intensities are required to maintain ground movements at a certain speed in very low visibilities or in bright daytime conditions, the intensity in red light and beam spreads of stop bar lights should be in accordance with the specifications of Appendix 2, Figure A2-17, A2-18 or A2-19.*

Note.— *High-intensity stop bars should only be used in case of an absolute necessity and following a specific study.*

5.3.19.12 **13 Recommendation.**— *Where a wide beam fixture is required, the intensity in red light and beam spreads of stop bar lights should be in accordance with the specifications of Appendix 2, Figure A2-17 or A2-19.*

5.3.19.13 **14** The lighting circuit shall be designed so that:

- a) stop bars located across entrance taxiways are selectively switchable;
- b) stop bars located across taxiways intended to be used only as exit taxiways are switchable selectively or in groups;
- c) when a stop bar is illuminated, any taxiway centre line lights installed beyond the stop bar shall be extinguished for a distance of at least 90 m; and
- d) stop bars shall be interlocked with the taxiway centre line lights so that when the centre line lights beyond the stop bar are illuminated the stop bar is extinguished and vice versa.

Note 1.— ~~*A stop bar is switched on to indicate that traffic stop and switched off to indicate that traffic proceed.*~~

Note 2.— *Care is required in the design of the electrical system to ensure that all of the lights of a stop bar will not fail at the same time. Guidance on this issue is given in the Aerodrome Design Manual (Doc 9157), Part 5.*

Rationale

Note 1. to existing paragraph 5.3.19.13 is proposed for deletion as Annex 14 is not considered to be the appropriate place to address this operational requirement.

5.3.22 Runway guard lights

Note.— The purpose of runway guard lights is to warn pilots, and drivers of vehicles when they are operating on taxiways, that they are about to enter an ~~active~~ runway. There are two standard configurations of runway guard lights as illustrated in Figure 5-28

Rationale

In regard to the proposed deletion of the word “active” in the Introductory Note, it is noted that the original intent of RGLs was to provide a final warning to flight crews and vehicle operators that they were immediately entering a runway. It is noted that a runway can switch between active and inactive several times a day and at any moment based on wind direction, etc. The original runway incursion prevention intent of providing RGLs at all runways, not only “active” runways, is proposed to be strengthened by the deletion of the word “active”.

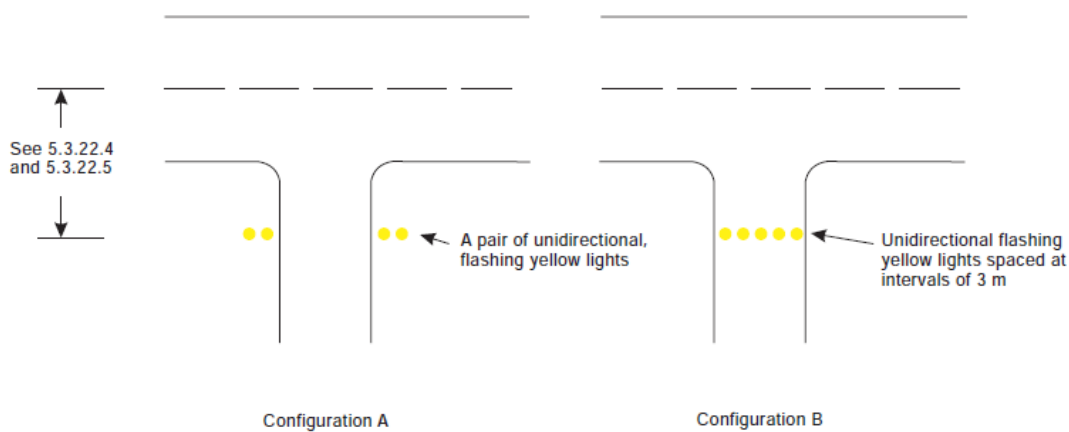

Figure 5-28. Runway guard lights

Application

5.3.22.1 Runway guard lights, Configuration A, shall be provided at each taxiway/runway intersection associated with a runway intended for use in:

- a) runway visual range conditions less than a value of 550 m where a stop bar is not installed; and
- b) runway visual range conditions of values between 550 m and 1 200 m where the traffic density is heavy.

5.3.22.2 Recommendation. ~~As part of runway incursion prevention measures, Runway guard lights, Configuration A or B, should be provided at each taxiway/runway intersection and used under all weather conditions during day and night. associated with a runway intended for use in:~~

~~a) runway visual range conditions of values less than a value of 550 m where a stop bar is installed; and~~

~~b) runway visual range conditions of values between 550 m and 1 200 m where the traffic density is medium or light.~~

~~5.3.22.3 Recommendation. Runway guard lights, Configuration A or Configuration B or both, should be provided at each taxiway/runway intersection where enhanced conspicuity of the taxiway/runway intersection is needed, such as on a wide throat taxiway, except that Configuration B should not be collocated with a stop bar.~~

...

Rationale

It is considered that the original intent of the Runway Guard Lights (RGLs) was not being met by the visibility requirement of the Annex. Since runway incursions occur during all weather conditions, and, in fact, more often occur in good visibilities, it was decided to remove the link to operating visibilities in 5.3.22.2 and recommend installation at all runway/taxiway intersections. In addition, this results in the proposed deletion of 5.3.22.2 (sub a and b) and 5.3.22.3.

CHAPTER 6 – VISUAL AIDS FOR DENOTING OBSTACLES

6.1 Objects to be marked and/or lighted

Editorial Note.— Please note renumbering of Chapter 6.

Note – The marking and/or lighting of obstacles is intended to reduce hazards to aircraft by indicating the presence of the obstacles. It does not necessarily reduce operating limitations which may be imposed by an obstacle.

6.1.1 Objects within obstacle limitation surfaces (within the lateral boundaries of the OLS)

~~6.1.6~~ 6.1.1.1 Vehicles and other mobile objects, excluding aircraft, on the movement area of an aerodrome are obstacles and shall be marked and, if the vehicles and aerodrome are used at night or in conditions of low visibility, lighted, except that aircraft servicing equipment and vehicles used only on aprons may be exempt.

~~6.1.7~~ 6.1.1.2 Elevated aeronautical ground lights within the movement area shall be marked so as to be conspicuous by day. Obstacle lights shall not be installed on elevated ground lights or signs in the movement area.

~~6.1.8~~ 6.1.1.3 All obstacles within the distance specified in Table 3-1, column 11 or 12, from the centre line of a taxiway, an apron taxiway or aircraft stand taxilane shall be marked and, if the taxiway, apron taxiway or aircraft stand taxilane is used at night, lighted.

~~6.1.1~~ 6.1.1.4 **Recommendation** – A fixed obstacle that extends above a take-off climb surface within 3000 m of the inner edge of the take-off climb surface should be marked and, if the runway is used at night, lighted, except that:

- a) such marking and lighting may be omitted when the obstacle is shielded by another fixed obstacle;
- b) the marking may be omitted when the obstacle is lighted by medium-intensity obstacle lights, Type A, by day and its height above the level of the surrounding ground does not exceed 150 m;
- c) the marking may be omitted when the obstacle is lighted by high-intensity obstacle lights by day;
and
- d) the lighting may be omitted where the obstacle is a lighthouse and an aeronautical study indicates the lighthouse light to be sufficient.

~~6.1.2~~ 6.1.1.5 **Recommendation** – A fixed object, other than an obstacle, adjacent to a take-off climb surface should be marked and, if the runway is used at night, lighted if such marking and lighting is considered necessary to ensure its avoidance, except that the marking may be omitted when:

- a) the object is lighted by medium-intensity obstacle lights, Type A, by day and its height above the

level of the surrounding ground does not exceed 150 m; or

b) the object is lighted by high-intensity obstacle lights by day.

~~6.1.3~~ **6.1.1.6** A fixed obstacle that extends above an approach or transitional surface within 3000 m of the inner edge of the approach surface or above a transitional surface shall be marked and, if the runway is used at night, lighted, except that:

- a) such marking and lighting may be omitted when the obstacle is shielded by another fixed obstacle;
- b) the marking may be omitted when the obstacle is lighted by medium-intensity obstacle lights, Type A, by day and its height above the level of the surrounding ground does not exceed 150 m;
- c) the marking may be omitted when the obstacle is lighted by high-intensity obstacle lights by day; and
- d) the lighting may be omitted where the obstacle is a lighthouse and an aeronautical study indicates the lighthouse light to be sufficient.

~~6.1.4~~ **6.1.1.7** **Recommendation** – *A fixed obstacle that extends above a horizontal surface should be marked and, if the aerodrome is used at night, lighted, except that:*

- a) *such marking and lighting may be omitted when:*
 - a. the obstacle is shielded by another fixed obstacle; or*
 - b. for a circuit extensively obstructed by immovable objects or terrain, procedures have been established to ensure safe vertical clearance below prescribed flight paths; or*
 - c. an aeronautical study shows the obstacle not to be of operational significance;*
- b) *the marking may be omitted when the obstacle is lighted by medium-intensity obstacle lights, Type A, by day and its height above the level of the surrounding ground does not exceed 150 m;*
- c) *the marking may be omitted when the obstacle is lighted by high-intensity obstacle lights by day; and*
- d) *the lighting may be omitted where the obstacle is a lighthouse and an aeronautical study indicates the lighthouse light to be sufficient.*

~~6.1.5~~ **6.1.1.8** A fixed object that extends above an obstacle protection surface shall be marked and, if the runway is used at night, lighted.

Note – See 5.3.5 for information on the obstacle protection surface.

6.1.1.9 Recommendation – *Other objects inside the obstacle limitation surfaces should be marked and/or lighted if an aeronautical study indicates that the object could constitute a hazard to aircraft (this includes objects adjacent to visual routes e.g. waterway or highway).*

Note.- See note below 4.4.2.

~~6.1.10~~ **6.1.1.10 Recommendation** – *Overhead wires, cables, etc., crossing a river, waterway, valley or highway should be marked and their supporting towers marked and lighted if an aeronautical study indicates that the wires or cables could constitute a hazard to aircraft.*

6.1.2 Objects outside obstacle limitation surfaces (outside the lateral boundaries of the OLS).

~~6.1.9~~ **6.1.2.1 Recommendation** – *Obstacles in accordance with 4.3.2 should be marked and lighted, except that the marking may be omitted when the obstacle is lighted by high-intensity obstacle lights by day.*

6.1.2.32 Recommendation – *Other objects outside the obstacle limitation surfaces should be marked and/or lighted if an aeronautical study indicates that the object could constitute a hazard to aircraft (this includes objects adjacent to visual routes e.g. waterway, highway).*

~~6.1.10~~ **6.1.2.43 Recommendation** – *Overhead wires, cables, etc., crossing a river, waterway, valley or highway should be marked and their supporting towers marked and lighted if an aeronautical study indicates that the wires or cables could constitute a hazard to aircraft.*

6.2 Marking and/or lighting of objects

6.2.1 General

~~6.3.1~~ **6.2.1.1** The presence of objects which must be lighted, as specified in 6.1, shall be indicated by low-, medium- or high-intensity lights, or a combination of such lights.

~~6.3.23~~ **6.2.1.2** Low-intensity obstacle lights ~~on fixed objects~~, Types A and B, C and D, medium-intensity obstacle lights, types A, B and C, high-intensity obstacle lights Type A and B, shall be in accordance with the specifications in Table 6-3 and Appendix 1, ~~shall be fixed red lights.~~

~~6.3.22~~ **6.2.1.3** The number and arrangement of low-, medium- or high-intensity obstacle lights at each level to be marked shall be such that the object is indicated from every angle in azimuth. Where a light is shielded in any direction by another part of the object, or by an adjacent object, additional lights shall be provided on that adjacent object or the part of the object that is shielding the light, in such a way as to retain the general definition of the object to be lighted. If the shielded light does not contribute to the definition of the object to be lighted, it may be omitted.

6.2.2 Mobile objects

Marking

~~6.2.2~~ **6.2.2.1** All mobile objects to be marked shall be coloured or display flags.

Marking by colour

~~6.2.6~~ **6.2.2.2 Recommendation** – *When mobile objects are marked by colour, a single conspicuous*

colour, preferably red or yellowish green for emergency vehicles and yellow for service vehicles should be used.

Marking by flags

~~6.2.11~~ 6.2.2.3 Flags used to mark mobile objects shall be displayed around, on top of, or around the highest edge of the object. ~~When flags are used to mark extensive objects or groups of closely spaced objects, they shall be displayed at least every 15 m.~~ Flags shall not increase the hazard presented by the object they mark.

~~6.2.12~~ 6.2.2.4 Flags used to mark mobile objects shall not be less than 0.9 m square on each side and shall consist of a chequered pattern, each square having sides of not less than 0.3 m. The colours of the pattern shall contrast each with the other and with the background against which they will be seen. Orange and white or alternatively red and white shall be used, except where such colours merge with the background.

Lighting

~~6.3.4~~ 6.2.2.5 Low intensity obstacle lights, Type C, shall be displayed on vehicles and other mobile objects excluding aircraft.

Note – See Annex 2 for lights to be displayed by aircraft.

~~6.3.25~~ 6.2.2.6 Low intensity obstacle lights, Type C, displayed on vehicles associated with emergency or security shall be flashing-blue and those displayed on other vehicles shall be flashing-yellow.

~~6.3.5~~ 6.2.2.7 Low intensity obstacle lights, type D, shall be displayed on follow-me vehicles.

~~6.3.28~~ 6.2.2.8 Low intensity obstacle lights on objects with limited mobility such as aerobridges shall be fixed-red, and as a minimum be in accordance with the specifications for low-intensity obstacle lights, type A, in table 6-3. The intensity of the lights shall be sufficient to ensure conspicuity considering the intensity of the adjacent lights and the general levels of illumination against which they would normally be viewed.

6.2.3 Fixed objects

Marking

~~6.2.1~~ 6.2.3.1 All fixed objects to be marked shall, whenever practicable, be coloured, but if this is not practicable, markers or flags shall be displayed on or above them, except that objects that are sufficiently conspicuous by their shape, size or colour need to be otherwise marked.

Marking by colour

~~6.2.3~~ 6.2.3.2 **Recommendation** – An object should be coloured to show a chequered pattern if it has essentially unbroken surfaces and its projection on any vertical plane equals or exceeds 4.5 m in both dimensions. The pattern should consist of rectangles not less than 1.5 m and not more than 3 m on a side, the corners being of the darker colour. The colours of the pattern should contrast each with the other and

with the background against which they will be seen. Orange and white or alternatively red and white should be used, except where such colours merge with the background. (see figure 6-1).

~~6.2.4~~ **6.2.3.3 Recommendation** – An object should be coloured to show alternating contrasting bands if:

- a) it has essentially unbroken surfaces and has one dimension, horizontal or vertical, greater than 1.5 m, and the other dimension, horizontal or vertical, less than 4.5 m; or
- b) it is of skeletal type with either a vertical or a horizontal dimension greater than 1.5 m.

The bands should be perpendicular to the longest dimension and have a width approximately 1/7 of the longest dimension or 30 m, whichever is less. The colours of the bands should contrast with the background against which they will be seen. Orange and white should be used, except where such colours are not conspicuous when viewed against the background. The bands on the extremities of the object should be of the darker colour. (see figure 6-1 and 6-2).

Note – Table 6-1 shows a formula for determining band widths and for having an odd number of bands, thus permitting both the top and bottom bands to be of the darker colour.

~~6.2.5~~ **6.2.3.4 Recommendation** – An object should be coloured in a single conspicuous colour if its projection on any vertical plane has both dimensions less than 1.5 m. Orange or red should be used, except where such colours merge with the background.

Note – Against some backgrounds it may be found necessary to use a different colour from orange or red to obtain sufficient contrast.

Marking by flags

~~6.2.11~~ **6.2.3.5** Flags used to mark **fixed** objects shall be displayed around, on top of, or around the highest edge of the object. When flags are used to mark extensive objects or a group of closely spaced objects, they shall be displayed at least every 15 m. Flags shall not increase the hazard presented by the object they mark.

~~6.2.12~~ **6.2.3.6** Flags used to mark fixed objects shall not be less than 0.6 m square on each side and flags used to mark mobile objects, not less than 9 m square.

~~6.2.14~~ **6.2.3.7 Recommendation** – **Flags used to mark fixed mobile objects should be orange in colour or a combination of two triangular sections, one orange and the other white, or one red and the other white, except that where such colours merge with the background, other conspicuous colours should be used.**

Marking by markers

~~6.2.7~~ **6.2.3.8** Markers displayed on or adjacent to objects shall be located in conspicuous positions so as to retain the general definition of the object and shall be recognizable in clear weather from a distance of at least 1000 m for an object to be viewed from the air and 300 m for an object to be viewed from the ground in all directions in which an aircraft is likely to approach the object. The shape of markers shall be

distinctive to the extent necessary to ensure that they are not mistaken for markers employed to convey other information, and they shall be such that the hazard presented by the object they mark is not increased.

~~6.2.10~~ **6.2.3.9 Recommendation** – *A marker should be of one colour. When installed, white and red, or white and orange markers should be displayed alternately. The colour selected should contrast with the background against which it will be seen.*

Lighting

~~6.3.11~~ **6.2.3.10** In case of an object to be lighted one or more low-, medium- or high-intensity obstacle lights shall be located as close as practicable to the top of the object. ~~The top lights shall be so arranged as to at least indicate the points or edges of the object highest in relation to the obstacle limitation surface.~~

Note – Recommendations on how a combination of low-, medium-, and/or high-intensity lights on obstacles should be displayed are given in Appendix 6.

~~6.3.12~~ **6.2.3.11 Recommendation** – *In the case of a chimney or other structure of like function, the top lights should be placed sufficiently below the top so as to minimize contamination by smoke etc. (see Figures 6-2 and 6-3. (see figure 6-2).*

~~6.3.13~~ **6.2.3.12** In the case of a tower or antenna structure indicated by high-intensity obstacle lights by day with an appurtenance, such as a rod or an antenna, greater than 12 m where it is not practicable to locate a high intensity obstacle light on top of the appurtenance, such a light shall be located at the highest practicable point and, if practicable, a medium-intensity obstacle light, type A, mounted on the top.

~~6.3.14~~ **6.2.3.13** In case of an extensive object or a group of closely spaced objects to be lighted that are:

- a) penetrating a horizontal OLS or located outside an OLS, the top lights shall be so arranged as to at least indicate the points or edges of the object highest in relation to the obstacle limitation surface or above the ground, and so as to indicate the general definition and the extent of the objects; and
- b) penetrating a sloping OLS the top lights shall be so arranged as to at least indicate the points or edges of the object highest in relation to the obstacle limitation surface, and so as to indicate the general definition and the extent of the objects. If two or more edges are of the same height, the edge nearest the landing area shall be marked.

~~6.3.15~~ **6.2.3.14 Recommendation** - *When the obstacle limitation surface concerned is sloping and the highest point above the obstacle limitation surface is not the highest point of the object, additional obstacle lights should be placed on the highest point of the object.*

6.2.3.15 Where lights are applied to display the general definition of an extensive object or a group of closely spaced objects, and

- a) low-intensity lights are used, they shall be spaced at longitudinal intervals not exceeding 45 m.
- b) medium-intensity lights are used, they shall be spaced at longitudinal intervals not exceeding 900 m.

~~6.3.32~~ **6.2.3.16** High-intensity obstacle lights, Type A, ~~M~~ medium-intensity obstacle lights, Types A and B, located on an object shall flash simultaneously.

~~6.3.24~~ **6.2.3.17 Recommendation** – *The installation setting angles for high-intensity obstacle lights, Types A ~~and B~~, should be in accordance with Table 6-2.*

Note – High intensity obstacle lights are intended for day use as well as night use. Care is needed to ensure that these lights do not create disconcerting dazzle. Guidance on the design, operation and the location of high-intensity obstacle lights is given in the Aerodrome Design Manual, Part 4.

~~6.3.10~~ **6.2.3.18 Recommendation** – *Where, in the opinion of the appropriate authority, the use of high-intensity obstacle lights, type A, or medium-intensity obstacle lights, Type A ~~or B~~, at night may dazzle pilots in the vicinity of an aerodrome (within approximately 10 000 m radius) or cause significant environmental concerns, a dual obstacle lighting system should be provided. This system should be composed of high intensity obstacle lights, Type A ~~or B~~ or medium intensity obstacle lights, Type A, as appropriate, for daytime and twilight use and medium-intensity obstacle light, Type B or C, for night-time use.*

Objects with a height less than 45m above the level of the surrounding ground

~~6.3.2~~ **6.2.3.19 Recommendation** – *Low-intensity obstacle lights, Type A or B, should be used where the object is a less extensive one and its height above the surrounding ground is less than 45 m.*

~~6.3.3~~ **6.2.3.20 Recommendation** – *Where the use of low-intensity obstacle lights, Type A or B, would be inadequate or an early special warning is required, then medium- or high-intensity obstacle lights should be used.*

~~6.3.6~~ **6.2.3.21 Recommendation** – *Low-intensity obstacle lights, Type B, should be used either alone or in combination with medium-intensity obstacle lights, Type B, in accordance with ~~6.3.7~~ 6.2.3.22.*

~~6.3.7~~ **6.2.3.22 Recommendation** – *Medium-intensity obstacle lights, Type A, B or C, should be used where the object is an extensive one ~~or its height above the level of the surrounding ground is greater than 45 m~~. Medium-intensity obstacle lights, Types A and C, should be used alone, whereas medium intensity obstacle lights, Type B, should be used either alone or in combination with low-intensity obstacle lights, Type B.*

Note – A group of ~~trees or~~ buildings is regarded as an extensive object.

Objects with a height not more than 150 m but not less than 45m above the level of the surrounding ground

~~6.3.7~~ **6.2.3.23 Recommendation** – *Medium-intensity obstacle lights, Type A, B or C, should be used ~~where the object is an extensive one or its height above the surrounding ground is greater than 45m~~. Medium-intensity obstacle lights, Types A and C, should be used alone, whereas medium intensity obstacle lights, Type B, should be used either alone or in combination with low-intensity obstacle lights, Type B.*

~~6.3.16~~ **6.2.3.24** Where an object is indicated by medium-intensity obstacle lights, Type A, and the top of the object is more than 105 m above the level of the surrounding ground or the elevation of tops of nearby

buildings (when the object to be marked is surrounded by buildings), additional lights shall be provided at intermediate levels. These additional intermediate lights shall be spaced as equally as practicable, between the top lights and ground level or the level of tops of nearby buildings, as appropriate, with the spacing not exceeding 105 m.

~~6.3.17~~ **6.2.3.25** Where an object is indicated by medium-intensity obstacle lights, Type B, and the top of the object is more than 45 m above the level of the surrounding ground or the elevation of tops of nearby buildings (when the object to be marked is surrounded by buildings), additional lights shall be provided at intermediate levels. These additional intermediate lights shall be alternately low-intensity obstacle lights, Type B, and medium-intensity obstacle lights, Type B, and shall be spaced as equally as practicable between the top lights and ground level or the level of tops of nearby buildings, as appropriate, with the spacing not exceeding 52 m.

~~6.3.18~~ **6.2.3.26** Where an object is indicated by medium-intensity obstacle lights, Type C, and the top of the object is more than 45 m above the level of the surrounding ground or the elevation of tops of nearby buildings (when the object to be marked is surrounded by buildings), additional lights shall be provided at intermediate levels. These additional intermediate lights shall be spaced as equally as practicable between the top lights and ground level or the level of tops of nearby buildings, as appropriate, with the spacing not exceeding 52 m.

~~6.3.19~~ **6.2.3.27** Where high-intensity obstacle lights, Type A, are used, they shall be spaced at uniform intervals not exceeding 105 m between the ground level and the top light(s) specified in ~~6.3.14~~ **6.2.3.10** except that where an object to be marked is surrounded by buildings, the elevation of the tops of the buildings may be used as the equivalent of the ground level when determining the number of light levels.

Objects which height exceeds 150 m above ground level or the level of the surrounding ground

~~6.3.8~~ **6.2.3.28 Recommendation** – *High-intensity obstacle lights, Type A, should be used to indicate the presence of an object if its height above the level of the surrounding ground exceeds 150 m and an aeronautical study indicates such lights to be essential for the recognition of the object by day.*

~~6.3.19~~ **6.2.3.29** Where high-intensity obstacle lights, Type A, are used, they shall be spaced at uniform intervals not exceeding 105 m between the ground level and the top light(s) specified in ~~6.3.14~~ **6.2.3.10** except that where an object to be marked is surrounded by buildings, the elevation of the tops of the buildings may be used as the equivalent of the ground level when determining the number of light levels.

~~6.3.7~~ **6.2.3.30 Recommendation** – *Medium-intensity obstacle lights, Type A, B or C, should be used, where the object is an extensive one or its height above the level of the surrounding ground is greater than 45m. Where, in the opinion of the appropriate authority, the use of high-intensity obstacle lights, Type A, at night may dazzle pilots in the vicinity of an aerodrome (within approximately 10 000 m radius) or cause significant environmental concerns, medium-intensity obstacle lights, Types A and C, should be used alone, whereas medium-intensity obstacle lights, Type B, should be used either alone or in combination with low-intensity obstacle lights, Type B.*

~~6.3.16~~ **6.2.3.31** Where an object is indicated by medium-intensity obstacle lights, Type A, ~~and the top of the object is more than 105 m above the level of the surrounding ground or the elevation of tops of nearby buildings (when the object to be marked is surrounded by buildings),~~ additional lights shall be provided at intermediate levels. These additional intermediate lights shall be spaced as equally as practicable, between the top lights and ground level or the level of tops of nearby buildings, as appropriate, with the spacing not

exceeding 105 m.

~~6.3.16~~ **6.2.3.32** Where an object is indicated by medium-intensity obstacle lights, Type A ~~B~~, and the top of the object is more than 105 m above the level of the surrounding ground or the elevation of tops of nearby buildings (when the object to be marked is surrounded by buildings), additional lights shall be provided at intermediate levels. These additional intermediate lights shall be alternately low-intensity obstacle lights, type B, and medium-intensity obstacle lights, type B, and shall be spaced as equally as practicable between the top lights and ground level or the level of tops of nearby buildings, as appropriate, with the spacing not exceeding 52 m.

~~6.3.18~~ **6.2.3.33** Where an object is indicated by medium-intensity obstacle lights, Type C, and the top of the object is more than 45 m above the level of the surrounding ground or the elevation of tops of nearby buildings (when the object to be marked is surrounded by buildings), additional lights shall be provided at intermediate levels. These additional intermediate lights shall be spaced as equally as practicable, between the top lights and ground level or the level of tops of nearby buildings, as appropriate, with the spacing not exceeding 52 m.

6.2.4 Wind turbines

Markings

~~6.1.2.2~~ **2.4.1A** wind turbine shall be marked and/or lighted if it is determined to be an obstacle.

Note – see 4.3.1 and 4.3.2

~~6.4.2~~ **6.2.4.12** **Recommendation** – *The rotor blades, nacelle and upper 2/3 of the supporting mast of wind turbines should be painted white, unless otherwise indicated by an aeronautical study.*

Lighting

~~6.4.3~~ **6.2.4.23** **Recommendation** – *When lighting is deemed necessary, medium intensity obstacle lights should be used. In the case of a wind farm, i.e. group of two or more wind turbines it should be regarded as an extensive object and the lights should be installed:*

- a) *to identify the perimeter of the wind farm;*
- b) *respecting the maximum spacing, in accordance with ~~6.3.14~~ 6.2.3.15, between the lights along the perimeter, unless a dedicated assessment shows that a greater spacing can be used;*
- c) *so that, where flashing lights are used, they flash simultaneously; and*
- d) *so that, within a wind farm, any wind turbines of significantly higher elevation are also identified wherever they are located.*

~~6.4.4~~ **6.2.4.34** **Recommendation** – *The obstacle lights should be installed on the nacelle in such a manner as to provide an unobstructed view for aircraft approaching from any direction.*

6.2.5 Overhead wires, cables, etc. and supporting towers

Marking

6.2.5.1 **Recommendation** - *The wires, cables, etc. to be marked should be equipped with markers; the supporting tower should be coloured.*

Marking by colours

~~6.1.10~~ 6.2.5.2 **Recommendation** - ~~*Overhead wires, cables, etc., crossing a river, valley or highway should be marked and their supporting towers marked and lighted if an aeronautical study indicates that the wires or cables could constitute a hazard to aircraft.*~~ *The supporting towers of overhead wires, cables, etc. should be marked in accordance with 6.2.3.1 to 6.2.3.4, except that the marking of the supporting towers may be omitted when they are lighted by high-intensity obstacle lights by day.*

Marking by markers

~~6.2.7~~ 6.2.5.3 Markers displayed on or adjacent to objects shall be located in conspicuous positions so as to retain the general definition of the object and shall be recognizable in clear weather from a distance of at least 1 000 m for an object to be viewed from the air and 300 m for an object to be viewed from the ground in all directions in which an aircraft is likely to approach the object. The shape of markers shall be distinctive to the extent necessary to ensure that they are not mistaken for markers employed to convey other information, and they shall be such that the hazard presented by the object they mark is not increased.

~~6.2.8~~ 6.2.5.4 **Recommendation** – *A marker displayed on an overhead wire, cable, etc. should be spherical and have a diameter of not less than 60 cm.*

~~6.2.9~~ 6.2.5.5 **Recommendation** – *The spacing between two consecutive markers or between a marker and a supporting tower should be appropriate to the diameter of the marker, but in no case should the spacing exceed:*

- a) *30 m where the marker diameter is 60 cm progressively increasing with the diameter of the marker to*
- b) *35 m where the marker diameter is 80 cm and further progressively increasing to a maximum of*
- c) *40 m where the marker diameter is of at least 130 cm.*

Where multiple wires, cables, etc. are involved, a marker should be located not lower than the level of the highest wire at the point marked.

~~6.2.10~~ 6.2.5.6 **Recommendation** – *A marker should be of one colour. When installed, white and red, or white and orange markers should be displayed alternately. The colour selected should contrast with the background against which it will be seen.*

~~6.1.11~~ 6.2.5.7 **Recommendation** – *When it has been determined that an overhead wire, cable, etc., needs to be marked but it is not practicable to install markers on the wire, cable, etc., then high-intensity obstacle lights, Type B, should be provided on their supporting towers.*

Lighting

~~6.3.9~~ **6.2.5.8 Recommendation** – High intensity obstacle lights, Type B, should be used to indicate the presence of the tower supporting overhead wires, cables, etc. where:

- a) an aeronautical study indicates such light to be essential for the recognition of the presence of wires, cables, etc.; or
- b) it has not been found practicable to install marker on the wires, cables, etc.

~~6.3.20~~ **6.2.5.9** Where high-intensity obstacle lights, Type B, are used, they shall be located at three levels:

- at the top of the tower;
- at the lowest level of the catenary of the wires or cables; and
- at approximately midway between these two levels.

Note -In some cases, this may require locating the lights off the tower.

~~6.3.36~~ **6.2.5.10 Recommendation** – High-intensity obstacle lights, Type B, indicating the presence of a tower supporting overhead wires, cables, etc., should flash sequentially; first the middle light, second the top light and last, the bottom light. The intervals between flashes of the lights should be approximate the following ratios:

Flash interval between	Ratio of cycle time
<i>middle and top light</i>	<i>1/13</i>
<i>top and bottom light</i>	<i>2/13</i>
<i>bottom and middle light</i>	<i>10/13.</i>

Editorial Note.— The following Note is re-located from existing 6.3.1.

Note – High intensity obstacle lights are intended for day use as well as night use. Care is needed to ensure that these lights do not create disconcerting dazzle. Guidance on the design, operation and the location of high-intensity obstacle lights is given in the Aerodrome Design Manual (Doc 9157), Part 4.

~~6.3.10~~ **6.2.5.11 Recommendation.-** Where, in the opinion of the appropriate authority, the use of high-intensity obstacle lights, Type A or B, or medium-intensity obstacle lights, Type A or B, at night may dazzle pilots in the vicinity of an aerodrome (within approximately 10 000 m radius) or cause significant environmental concerns, a dual obstacle lighting system should be provided. This system should be composed of high-intensity obstacle lights, Type A or B, or medium-intensity obstacle lights, Type A, as appropriate, for daytime and twilight use and medium-intensity obstacle lights, Type B or C, for night-time use. Where medium-intensity lights are used they should be installed at the same level as the high-intensity

obstacle light Type B.

6.3.21 6.2.5.12 **Recommendation** – The installation setting angles for high-intensity obstacle lights, Types A and B, should be in accordance with Table 6-2.

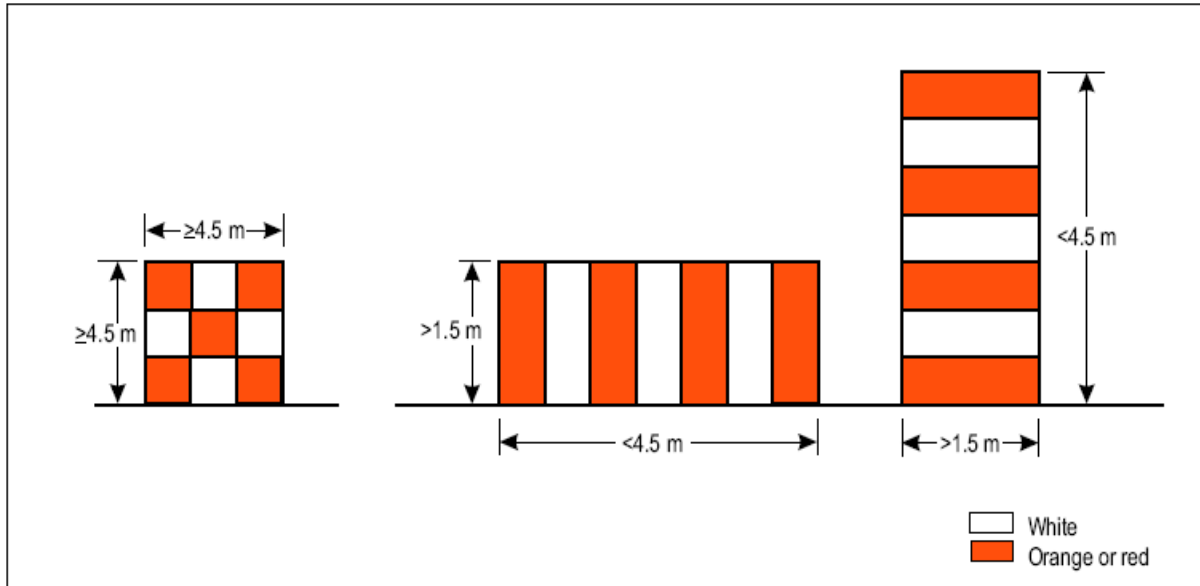

Figure 6-1. Basic marking patterns

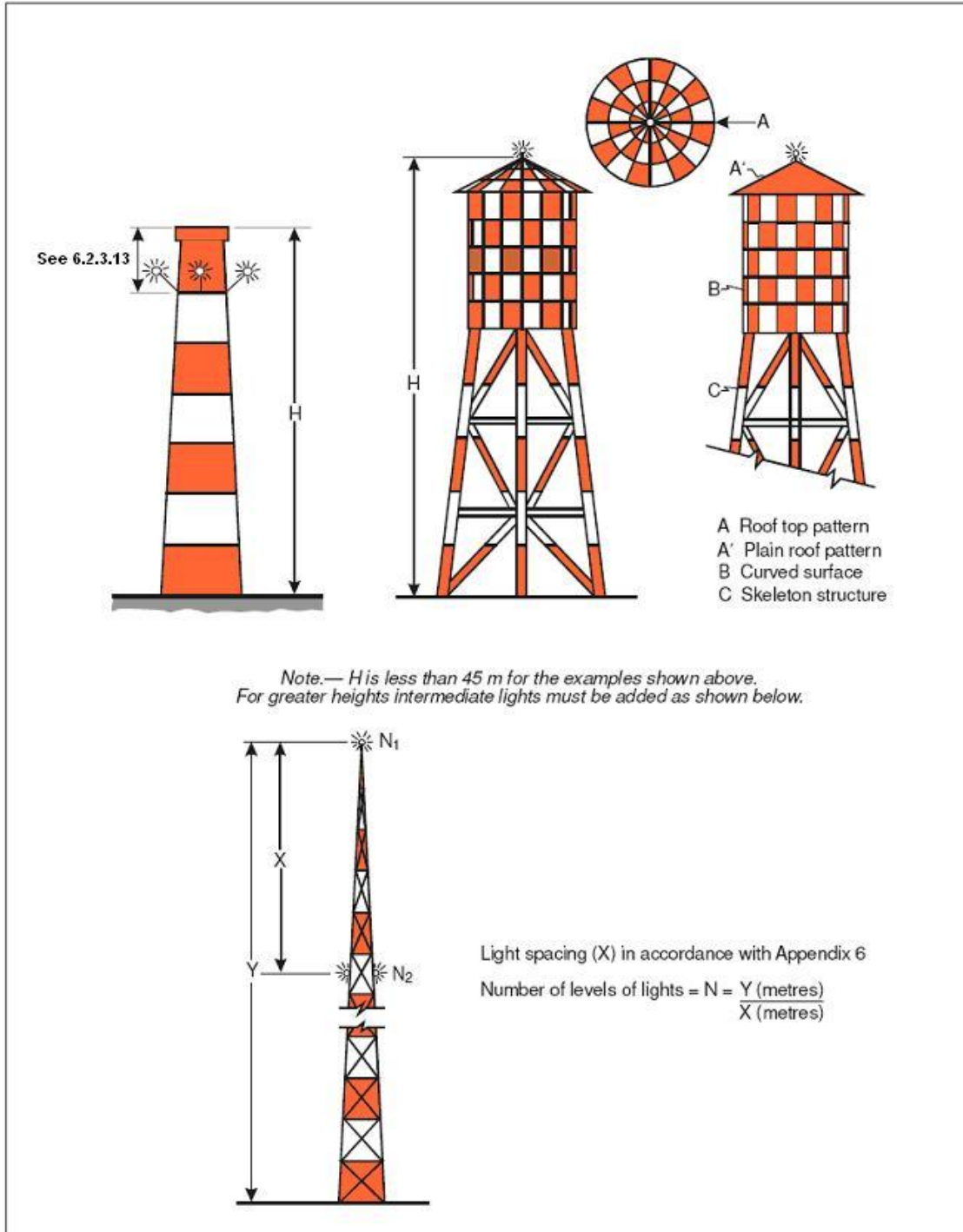

Figure 6-2. Examples of marking and lighting of tall structures

Figure 6-3 Lighting of buildings

Table 6-1 Marking band widths

Greater than	Longest dimension		Band width		
	Not exceeding				
1.5 m	210 m		1/7 of longest dimension		
210 m	270 m		1/9	“	“
270 m	330 m		1/11	“	“
330 m	390 m		1/13	“	“
390 m	450 m		1/15	“	“
450 m	510 m		1/17	“	“
510 m	570 m		1/19	“	“
570 m	630 m		1/21	“	“

Table 6-2 Installation setting angles for high-intensity obstacle lights

Height of light unit above terrain	Angle of the peak of the beam above the horizontal
Greater than 151 m AGL	0°
122 m to 151 m AGL	1°
92 m to 122 m AGL	2°
Less than 92 m AGL	3°

Table 6-3. Characteristics of obstacle lights

1	2	3	4			5	6	7
Light Type	Colour	Signal type/ (Flash rate)	Benchmark intensity (cd) at given Background Luminance (b)			Light Distribution Table		
			Day (Above 500 cd/m ²)	Twilight (50-500 cd/m ²)	Night (Below 50 cd/m ²)			
Low-intensity, Type A (fixed obstacle)	Red	Fixed	N/A	N/A	10	6-X		
Low-intensity, Type B (fixed obstacle)	Red	Fixed	N/A	N/A	32	6-X		
Low-intensity, Type C (mobile obstacle)	Yellow/ Blue (a)	Flashing (60-90 fpm)	N/A	40	40	6-X		
Low-intensity, Type D Follow-me vehicle	Yellow	Flashing (60-90 fpm)	N/A	200	200	6-X		
Medium-intensity, Type A	White	Flashing (20-60 fpm)	20 000	20 000	2 000	6-Y		

Medium-intensity, Type B	Red	Flashing (20-60 fpm)	N/A	N/A	2 000	6-Y
Medium-intensity, Type C	Red	Fixed	N/A	N/A	2 000	6-Y
High-intensity, Type A	White	Flashing (40-60 fpm)	200 000	20 000	2 000	6-Y
High-intensity, Type B	White	Flashing (40-60 fpm)	100 000	20 000	2 000	6-Y

(a) See §6.2.2.6

(b) For flashing lights, effective intensity as determined in accordance with the Aerodrome Design Manual, Part 4.

Table 6-X Light distribution for low intensity obstacle lights

	Minimum intensity (a)	Maximum intensity (a)	Vertical beam spread (f)	
			Minimum beam spread	Intensity
Type A	10cd (b)	N/A	10°	5cd
Type B	32cd (b)	N/A	10°	16cd
Type C	40cd (b)	400cd	12° (d)	20cd
Type D	200cd (c)	400cd	N/A (e)	N/A

Note.— This table does not include recommended horizontal beam spreads. 6.2.1.3 requires 360° coverage around an obstacle. Therefore, the number of lights needed to meet this requirement will depend on the horizontal beam spreads of each light as well as the shape of the obstacle. Thus, with narrower beam spreads, more lights will be required.

(a) 360° horizontal. For flashing lights, the intensity is read into effective intensity, as determined in accordance with the Aerodrome Design Manual, Part 4.

(b) Between 2 and 10° vertical. Elevation vertical angles are referenced to the horizontal when the light is levelled.

(c) Between 2 and 20° vertical. Elevation vertical angles are referenced to the horizontal when the light is levelled.

(d) Peak intensity should be located at approximately 2.5° vertical.

(e) Peak intensity should be located at approximately 17° vertical.

(f) Beam spread is defined as the angle between the horizontal plan and the directions for which the intensity exceeds that mentioned in the “intensity” column.

Table 6-Y Light distribution for medium and high intensity obstacle lights according to benchmark intensities of table 6-3

Benchmark intensity	Minimum requirements					Recommendations				
	Vertical elevation angle (b)			Vertical beam spread (c)		Vertical elevation angle (b)			Vertical beam spread (c)	
	0°		-1°			0°	-1°	-10°		
	Minimum average intensity (a)	Minimum intensity (a)	Minimum intensity (a)	Minimum beam spread	Intensity (a)	Maximum intensity (a)	Maximum intensity (a)	Maximum intensity (a)	Maximum beam spread	Intensity (a)
200 000	200 000	150 000	75 000	3°	75 000	250 000	112 500	7 500	7°	75 000
100 000	100 000	75 000	37 500	3°	37 500	125 000	56 250	3 750	7°	37 500
20 000	20 000	15 000	7 500	3°	7 500	25 000	11 250	750	N/A	N/A
2 000	2 000	1 500	750	3°	750	2 500	1 125	75	N/A	N/A

Note.— This table does not include recommended horizontal beam spreads. 6.2.1.3 requires 360° coverage around an obstacle. Therefore, the number of lights needed to meet this requirement will depend on the horizontal beam spreads of each light as well as the shape of the obstacle. Thus, with narrower beam spreads, more lights will be required.

- (a) 360° horizontal. All intensities are expressed in Candela. For flashing lights, the intensity is read into effective intensity, as determined in accordance with the Aerodrome Design Manual, Part 4.
- (b) Elevation vertical angles are referenced to the horizontal when the light unit is levelled.
- (c) Beam spread is defined as the angle between the horizontal plan and the directions for which the intensity exceeds that mentioned in the “intensity” column.

Note.— an extended beam spread may be necessary under specific configuration and justified by an aeronautical study.

	<i>RATIONALE</i> Restructure of Chapter 6 to improve readability for end user (e.g.: obstacle owners)	
Old number	What happened?/why?	New number
Note	We have put this note in 6.1 as a general item because it is applicable to all kind of marking and lighting.	Note below 6.1
6.1.1	We have put this in section 6.1.1 because it is only applicable to obstacles within obstacle limitation surfaces.	6.1.1.4
6.1.2	We have put this in section 6.1.1 because it is only applicable to obstacles within obstacle limitation surfaces.	6.1.1.5
6.1.3	We have put this in section 6.1.1 because it is only applicable to obstacles within obstacle limitation surfaces. We also changed the wording “ <i>a fixed obstacle that extends above an approach or transitional surface within 3000 m of the inner edge of the approach surface shall be marked and, if the runway is used at night, lighted...</i> ” into “ <i>a fixed obstacle that extends above an approach surface within 3000 m of the inner edge or above a transitional surface shall be marked and, if the runway is used at night, lighted...</i> ”, because this corresponds with 4.2.10 and clarifies the application.	6.1.1.6
6.1.4	We have put this in section 6.1.1 because it is only applicable to obstacles within obstacle limitation surfaces.	6.1.1.7
6.1.5	We have put this in section 6.1.1 because it is only applicable to obstacles within obstacle limitation surfaces.	6.1.1.8
Note	We have put this in section 6.1.1 because it is only applicable to obstacles within obstacle limitation surfaces.	Note below 6.1.1.8
6.1.6	We have put this into section 6.1.1 because it is only applicable to mobile objects within the obstacle limitation surfaces. (Since the movement area is located within the area of the obstacle limitation surfaces.)	6.1.1.1
6.1.7	We have put this into section 6.1.1 because it is only applicable to elevated ground lights, etc. on the movement area. (Since the movement area is located within the area of the obstacle limitation surfaces.)	6.1.1.2
6.1.8	We have put this into section 6.1.1 because it is only applicable to objects on the movement area. (Since the movement area is located within the area of the obstacle limitation surfaces.)	6.1.1.3
6.1.9	We have put this into section 6.1.2 because it is only applicable to objects outside the obstacle limitation surfaces.	5.1.2.1
6.1.10	We have put the first part of this article into section 6.1.1 and 6.1.2 because it could apply to cables, etc. outside obstacle limitation surfaces as well as cables, etc. within obstacle limitation surfaces. [We also added the word waterway beside river, valley or highway because a waterway may be used as a visual flight route. The definition waterway covers more the definition river (e.g. canals). On the other hand a river is not always a waterway.] We have put the second part of this article into the marking part of 6.2.4 because it is regulating how these structures have to be marked and/or lighted.	First part in 6.1.1.10 and 6.1.2.3 Second part in 2 nd part of 6.2.5.2
6.1.11	We have put this section into section 6.2.5 because it only addresses how wires, cables, etc. have to be marked and/or their supporting towers lighted,	6.2.5.7
6.2.1	We have put this in the general marking section of fixed objects	6.2.3.1

	(6.2.3.) because it is applicable to all fixed objects to be marked. It says that the object shall be coloured or display markers or flags.	
6.2.2	We have put this in the marking section of mobile objects because it is only applicable to the marking of mobile objects.	6.2.2.1
6.2.3	We have put this in the marking section of fixed objects (6.2.3) because it recommends how a fixed object should be marked.	6.2.3.2
6.2.4	We have put this in the marking section of fixed objects (6.2.3) because it recommends how a fixed object should be marked.	6.2.3.3
Note	We have put this in the marking section of fixed objects (6.2.3) because it recommends how a fixed object should be marked.	Note below 6.2.3.3
6.2.5	We have put this in the marking section of fixed objects (6.2.3) because it recommends how a fixed object should be marked.	6.2.3.4
Note	We have put this in the marking section of fixed objects (6.2.3) because it recommends how a fixed object should be marked.	Note below 6.2.3.4
6.2.6	We have put this in the marking section of mobile objects (6.2.2 marking by colour) since it recommends how a mobile object should be marked by a colour.	6.2.2.2
6.2.7	We have put this article in the part marking by markers' of fixed objects (6.2.3) and the part 'marking by markers' of overhead wires, cables, etc. (6.2.5) since it is regulated how markers shall be displayed. Markers are especially used at cables, wires, etc., but can also be applied to fixed objects.	6.2.3.8 and 6.2.5.3
6.2.8	We have put this in the 'marking by markers section of overhead wires, cables, etc. (6.2.5) because it is applicable to markers displayed on an overhead wires, cable, etc.	6.2.5.4
6.2.9	We have put this in the 'marking by markers section of overhead wires, cables, etc. (6.2.5) because it is applicable to markers displayed on an overhead wires, cable, etc.	6.2.5.5
6.2.10	We have put this article in the part marking by markers' of fixed objects (6.2.3) and the part 'marking by markers' of overhead wires, cables, etc. (6.2.5) since it recommends how markers shall be coloured. Markers are especially used at cables, wires, etc., but can also be applied to fixed objects.	6.2.3.9 and 6.2.5.6
6.2.11	We have put this article in the part 'marking by flags' of <u>fixed</u> objects (6.2.3). We have also put the first part of this article in the section 'marking by flags' of mobile objects (6.2.2) because it is also applicable to mobile objects. However the last part (applicable to a group of extensive objects, we left away because this will not be applicable to mobile objects.)	6.2.2.3 and 6.2.3.5
6.2.12	We have put the first part of this article in the part 'marking by flags' of fixed objects (6.2.3) because it is applicable to flags on fixed objects. The second part of this article is located in the part 'marking by flags' of mobile objects (6.2.2) because it is applicable to flags on mobile objects. The last part is merged with the old article 6.2.14.	6.2.2.4 and 6.2.3.6
6.2.13	We have put this in the part 'marking by flags' of fixed objects (6.2.3) because it is applicable to flags on fixed objects.	6.2.3.7
6.2.14	We have put this in the part 'marking by flags' of mobile objects (6.2.2) because it is applicable to flags on mobile objects. This article is merged with the 2 nd part of the old article 6.2.12.	6.2.2.4
6.3.1	We have put this article in the general part of marking and/or lighting of objects (6.2.1) because it is applicable to every object to be lighted.	6.2.1.1
Note	We have put this article in the general lighting part of fixed objects (6.2.3) and in the lighting part of overhead wires, etc. because it is	Note below 6.2.3.17 and note

	applicable to high intensity lights, which can be applied at fixed objects or structures of overhead wires, etc.	below 6.2.5.10
6.3.2	We have put this article in the lighting part of 'objects with a height less than 45 m...', because it is only applicable to objects with a height less than 45 m above...	6.2.3.19
6.3.3	We have put this article in the lighting part of 'objects with a height less than 45 m...', because it is only applicable to objects with a height less than 45 m above...	6.2.3.20
6.3.4	We have put this article in the part lighting of mobile objects since it is only applicable to mobile objects.	6.2.25
6.3.5	We have put this article in the part lighting of mobile objects since it is only applicable to mobile objects.	6.2.2.7
6.3.6	We have put this in the part lighting of 'objects with a height less than 45 m...' because it is only applicable to objects with a height less than 45 m...	6.2.3.21
6.3.7	We have put this article partly in the part lighting of 'objects with a height less than 45 m...' and removed the sentence 'or its height...than 45m' because this is not applicable. We have also put this article into the part lighting of 'objects with a height 45-150' and removed the sentence 'where the object...than 45 m' because this is not applicable. We have also put the last part in the part 'lighting of objects with a height more than 150m...' and we added the text 'where an object is indicated by MI lights' Because objects with a height more than 150 m... are normally indicated by HI lights.	6.2.3.22 and 6.2.3.23 and 6.2.3.30
Note	We have put this note below the new article 6.2.3.22 because it is related to that article	Note below 6.2.3.22
6.3.8	We have put this article in the part lighting of 'objects which height exceeds 150 m...' because it is applicable to objects higher than 150 m.	6.2.3.28
6.3.9	We have put this article in the lighting part of overhead wires, cables, etc. (6.2.5) because it is applicable to lighting of overhead wires, etc. and their structures.	6.2.5.8
6.3.10	We have put this article in the general lighting part of fixed objects because it could apply to all fixed objects. Since type A (HI) is only used at fixed objects (which do not include cables, etc.) we only mentioned type A. We have also put this article in the part lighting of overhead wires, etc. because it could also apply to lighting of wires and their structures. In this case we only mentioned type B (HI) because this type B is used only for overhead wires.	6.2.3.18 and 6.2.5.11
Note	We have put this note in the general lighting part of fixed objects because it is applicable to fixed objects.	Note below 6.2.3.10
6.3.11	We have put this article in the general lighting part of fixed objects, because it is related to lighting of fixed objects.	6.2.3.10 and 6.2.3.13
6.3.12	We have put this article in the general lighting part of fixed objects, because it is related to lighting of fixed objects.	6.2.3.11
6.3.13	We have put this article in the general lighting part of fixed objects, because it is related to lighting of fixed objects.	6.2.3.12
6.3.14	We have put this article in the general lighting part of fixed objects, because it is related to lighting of fixed objects. We also modified this part and split it into 2 separate articles.	6.2.3.13 and 6.2.3.15
6.3.15	We have put this article in the general lighting part of fixed objects, because it is related to lighting of fixed objects.	6.2.3.14

6.3.16	We have put this article in the lighting part of “objects with a height 45-150” and “objects with a height more than 150 m” because it could only apply to those objects. We only modified the article with regarding to objects higher than 150m.	6.2.3.24 6.2.3.31	and
6.3.17	We have put this article in the lighting part of “objects with a height 45-150” and “objects with a height more than 150 m” because it could only apply to those objects. We only modified the article with regarding to objects higher than 150m.	6.2.3.25 6.2.3.32	and
6.3.18	We have put this article in the lighting part of “objects with a height 45-150” and “objects with a height more than 150 m” because it could only apply to those objects. We only modified the article with regarding to objects higher than 150m.	6.2.3.26 6.2.3.33	and
6.3.19	We have put this article in the lighting part of “objects with a height 45-150” and “objects with a height more than 150 m” because it could only apply to those objects.	6.2.3.27 6.2.3.29	and
6.3.20	We have put this article in the part ‘lighting of overhead wires, cables, etc.’ because it is applicable to overhead wires, etc.	6.2.5.9	
6.3.21	We have put this in the general lighting part of fixed objects with a limitation to HI type A lights, because only HI type A will be used on fixed objects. We have also put this article in the lighting part of cables, wires, etc. because HI lights will also be used on these objects.	6.2.3.17 6.2.5.12	and
6.3.22	We have put this article in the general part of marking and/or lighting of objects (6.2.1) because it is applicable to every object to be lighted.	6.2.1.3	
6.3.23	We have put this article in the general part of marking and/or lighting of objects (6.2.1) because it is applicable to every object to be lighted. We changed the article into a reference to table 6-3 because the characteristics of the light are described in table 6-3.	6.2.1.2	
6.3.24	We have put this article in the general part of marking and/or lighting of objects (6.2.1) because it is applicable to every object to be lighted. We changed the article into a reference to table 6-3 because the characteristics of the light are described in table 6-3.	6.2.1.2	
6.3.25	We have put this article in the part lighting of mobile objects since it is only applicable to mobile objects.	6.2.2.6	
6.3.26	We have put this article in the general part of marking and/or lighting of objects (6.2.1) because it is applicable to every object to be lighted. We changed the article into a reference to table 6-3 because the characteristics of the light are described in table 6-3.	6.2.1.2	
6.3.27	We have put this article in the general part of marking and/or lighting of objects (6.2.1) because it is applicable to every object to be lighted. We changed the article into a reference to table 6-3 because the characteristics of the light are described in table 6-3.	6.2.1.2	
6.3.28	We have put this article in the part lighting of mobile objects since it is only applicable to mobile objects. We merged this article with the old article 6.3.29.	6.2.2.8	
Note	We have put this note in the part lighting of mobile objects since it is related to mobile objects.	Note 6.2.2.5	below
6.3.29	We have put this article in the part lighting of mobile objects since it is only applicable to mobile objects. We merged this article with the old article 6.3.28.	6.2.2.8	
6.3.30	We have put this article in the general part of marking and/or lighting of objects (6.2.1) because it is applicable to every object to be lighted. We changed the article into a reference to table 6-3 because	6.2.1.2	

	the characteristics of the light are described in table 6-3.	
6.3.31	We have put this article in the general part of marking and/or lighting of objects (6.2.1) because it is applicable to every object to be lighted. We changed the article into a reference to table 6-3 because the characteristics of the light are described in table 6-3.	6.2.1.2
6.3.32	We have put this article in the general lighting part of fixed objects and merged it with the old article 6.3.35.	6.2.3.16
6.3.33	We have put this article in the general part of marking and/or lighting of objects (6.2.1) because it is applicable to every object to be lighted. We changed the article into a reference to table 6-3 because the characteristics of the light are described in table 6-3.	6.2.1.2
6.3.34	We have put this article in the general part of marking and/or lighting of objects (6.2.1) because it is applicable to every object to be lighted. We changed the article into a reference to table 6-3 because the characteristics of the light are described in table 6-3.	6.2.1.2
6.3.35	We have put this article in the general lighting part of fixed objects and merged it with the old article 6.3.32.	6.2.3.16
6.3.36	We have put this article in the part 'lighting of overhead wires, cables, etc.' because it is applicable to overhead wires, etc.	6.2.5.10
6.4.1	We have put this in the part of wind turbines	6.2.4.1
6.4.2	We have put this in the part of wind turbines	6.2.4.2
6.4.3	We have put this in the part of wind turbines	6.2.4.3
6.4.4	We have put this in the part of wind turbines	6.2.4.4
Figure 6-2	Reference 6.3.12 was changed in 6.2.3.13	Figure 6-2
Figure 6-3	This figure introducing more confusion (too many lights) in regard with the text, it was better to delete it.	

CHAPTER 9. AERODROME OPERATIONAL SERVICES, EQUIPMENT AND INSTALLATIONS

9.1 Aerodrome emergency planning

...

Aerodrome emergency exercise

9.1.12 The plan shall contain procedures for periodic testing of the adequacy of the plan and for reviewing the results in order to improve its effectiveness.

Note.— *The plan includes all participating agencies and associated equipment.*

9.1.13 The plan shall be tested by conducting:

a) a full-scale aerodrome emergency exercise at intervals not exceeding two years; and b) partial emergency exercises in the intervening year to ensure that any deficiencies found during the full-scale aerodrome emergency exercise have been corrected; ~~and~~ ~~or~~

b) a series of modular tests commencing in the first year and concluding in a full scale emergency exercise at intervals not exceeding three years;

and reviewed thereafter, or after an actual emergency, so as to correct any deficiency found during such exercises or actual emergency.

Note 1.— *The purpose of a full-scale exercise is to ensure the adequacy of the plan to cope with different types of emergencies. The purpose of a partial exercise is to ensure the adequacy of the response to individual participating agencies and components of the plan, such as the communications system. The purpose of modular tests is to enable concentrated effort on specific components of established emergency plans.*

Note 2.— *Guidance material on airport emergency planning is available in the Airport Services Manual, Part 7.*

Rationale

The current requirement to conduct full scale aerodrome emergency field exercise every two years is proving difficult for some States because some emergency agencies that should be involved are unable and/or unwilling to participate.

The proposed modular approach will present an aerodrome operator an opportunity to conduct a series of tests (10 in total) for their emergency plans with more concentration and detail on a specific element. The 10 modules are to be conducted over a 3 year period and culminate in a full scale field exercise.

The modular approach should afford the aerodrome operator the opportunity to improve and/or enhance their aerodrome emergency plans because the modular concept will allow them to focus their attention on each element that comprises the 10 modules.

Emergencies in difficult environments

9.1.14 The plan shall include the ready availability of, and coordination with, appropriate specialist rescue services to be able to respond to emergencies where an aerodrome is located close to water and/or swampy areas and where a significant portion of approach or departure operations takes place over these areas.

9.1.15 **Recommendation.**— *At those aerodromes located close to water and/or swampy areas, or difficult terrain, the aerodrome emergency plan should include the establishment, testing and assessment at regular intervals of a predetermined response for the specialist rescue services.*

9.1.15A **Recommendation.**— *An assessment of the approach and departure areas within 1,000 m of the runway threshold should be carried out to determine the options available for intervention.*

Note.- Guidance material on assessing approach and departure areas within 1,000 m of runway thresholds can be found in Chapter 13 of the Airport Services Manual (Doc 9137), Part 1.

Rationale

It is well known and documented that aircraft accidents and incidents do occur predominantly within the vicinity of runway thresholds during aircraft approaches and/or departures. This can also be evidenced through the Airport Services Manual Part 1, Chapter 9 Figure 9-1.

At many aerodromes there are difficult environments, such as large bodies of water, swamps, mud flats, busy motorways, high density residential housing or similar. With a view to being able to expediently and safely respond to those environments, specialist equipment, knowledge and/or training may be required. Conducting assessments of difficult environments would assist in determining what specialist equipment, knowledge and/or training may be required for the preservation of life and/or property in the event of an aircraft accident or incident in these areas.

9.2 Rescue and fire fighting

Extinguishing agents

...

9.2.8 **Recommendation.**— *Both principal and complementary agents should normally be provided at an aerodrome.*

Note.— *Descriptions of the agents may be found in the Airport Services Manual (Doc 9137), Part 1.*

9.2.9 **Recommendation.**— *The principal extinguishing agent should be:*

a) a foam meeting the minimum performance level A; or

b) a foam meeting the minimum performance level B; or

c) a foam meeting the minimum performance Level C; or

d) a combination of these agents;

except that the principal extinguishing agent for aerodromes in categories 1 to 3 should preferably meet the minimum a performance level B or C foam.

Note.— *Information on the required physical properties and fire extinguishing performance criteria needed for a foam to achieve an acceptable performance level A, B or C rating is given in the Airport Services Manual (Doc 9137), Part 1.*

...

9.2.11 The amounts of water for foam production and the complementary agents to be provided on the rescue and fire fighting vehicles shall be in accordance with the aerodrome category determined under 9.2.3, 9.2.4, 9.2.5, 9.2.6 and Table 9-2, except that ~~these amounts may be modified as follows:~~

~~a) for aerodrome categories 1 and 2, up to 100 per cent of the water may be replaced by complementary agent; or~~

~~b) for aerodrome categories 3 to 10 when a foam meeting performance level A is used, up to 30 per cent of the water may be replaced by complementary agent.~~

For the purpose of agent substitution, 1 kg of complementary agent shall be taken as equivalent to 1.0L of water for foam production. ~~the following equivalents shall be used:~~

1 kg ~~complementary agent~~ = 1.0 L water for production of a foam meeting performance level A

1 kg ~~complementary agent~~ = 0.66 L water for production of a foam meeting performance level B

Note 1.— The amounts of water specified for foam production are predicated on an application rate of 8.2 L/min/m² for a foam meeting performance level A, ~~and~~ 5.5 L/min/m² for a foam meeting performance level B and 3.75L/min/m² for a foam meeting performance Level C.

Note 2.— When any other complementary agent is used, the substitution ratios need to be checked.

9.2.12 Recommendation.— *At aerodromes where operations by aeroplanes larger than the average size in a given category are planned, the quantities of water should be recalculated and the amount of water for foam production and the discharge rates for foam solution should be increased accordingly.*

Note.— ~~Additional~~ Guidance on the determination of quantities of water and discharge rates based on the largest overall length of aeroplane in a given category is available in Chapter 2 of the Airport Services Manual (Doc 9137), Part 1.

9.2.12A From 1 January 2015, at aerodromes where operations by aeroplanes larger than the average size in a given category are planned, the quantities of water shall be recalculated and the amount of water for foam production and the discharge rates for foam solution shall be increased accordingly.

Note.— Guidance on the determination of quantities of water and discharge rates based on the largest overall length of aeroplane in a given category is available in Chapter 2 of the Airport Services Manual (Doc 9137), Part 1.

9.2.13 The quantity of foam concentrates separately provided on vehicles for foam production shall be in proportion to the quantity of water provided and the foam concentrate selected.

...

9.2.16 Recommendation.— *When both a foam meeting performance level A and a foam meeting performance level B are to be used, the total amount of water to be provided for foam production should first be based on the quantity which would be required if only a foam meeting performance level A were used, and then reduced by 3 L for each 2 L of water provided for the foam meeting performance level B. When different performance level foams are provided at an aerodrome the conversion ratio should be calculated, documented for each rescue and fire fighting vehicle and applied to the overall rescue and fire fighting requirement.*

...

Table 9-2. Minimum usable amounts of extinguishing agents

Aerodrome category	Foam meeting performance level A		Foam meeting performance level B		Foam meeting performance level C		Complementary agents	
	Water (L)	Discharge rate foam solution/minute (L)	Water (L)	Discharge rate foam solution/minute (L)	Water (L)	Discharge rate Foam solution/minute (L)	Dry chemical powders (kg)	Discharge Rate (kg/second)
		(3)		(5)		(7)		
(1)	(2)	(3)	(4)	(5)	(6)	(7)	(8)	(9)
1	350	350	230	230	160	160	45	2.25
2	1 000	800	670	550	460	360	90	2.25
3	1 800	1 300	1 200	900	820	630	135	2.25
4	3 600	2 600	2 400	1 800	1 700	1 100	135	2.25
5	8 100	4 500	5 400	3 000	3 900	2 200	180	2.25
6	11 800	6 000	7 900	4 000	5 800	2 900	225	2.25
7	18 200	7 900	12 100	5 300	8 800	3 800	225	2.25
8	27 300	10 800	18 200	7 200	12 800	5 100	450	4.5
9	36 400	13 500	24 300	9 000	17 100	6 300	450	4.5
10	48 200	16 600	32 300	11 200	22 800	7 900	450	4.5

Note.— The quantities of water shown in columns 2, 4, and 6 are based on the average overall length of aeroplanes in a given category.

Rationale

For many years there have been two levels of foam available for RFF purposes, namely, performance levels A and B. Level A, which is a protein-based foam, requires more water for foam production than Level B foam as well as a greater discharge rate. Level C foam is, in essence, a concentrate of Level B foam, which requires less water for foam production, a lesser discharge rate and is more efficient in its extinguishing ability than Level B foam. The benefits of using Level C foam is that the size of fire vehicles can be reduced in agent carrying capacity (size) or, by using the same fire vehicles, the fire fighting capability is increased.

Table 9-2 was originally developed in the 1980's based on median aircraft in a given category. With today's range of aircraft, there are quite a few more aircraft types within the category, making the "older" calculations redundant for this purpose. For example, the Dash 8 – 400 series aircraft is a category 6 aircraft and the agent quantities listed in the current table may be adequate. However, the much larger Airbus A320, which has the capacity to carry greater amounts of fuel, is also a category 6 aircraft and the current table for agent quantities is most likely inadequate. A new Standard is now proposed in 9.2.12A which is an upgrade of existing RP 9.2.12, with a protection date of 1 January 2015. This date allows for a sufficient period of three years from the introduction of level C foam in 2012 for States and operators to prepare for the change. Arising from these proposals, aerodromes receiving aeroplanes no larger than the median in each category will continue to use Table 9-2 as stipulated in 9.2.11, whereas aerodromes receiving aeroplanes larger than the median will continue to use existing 9.2.12 as a Recommended Practice and as a Standard in 9.2.12A commencing 1 January 2015.

...

9.2.21 Recommendation.— ~~A reserve supply of foam concentrate and complementary agent, equivalent to 200 per cent of the quantities of these agents to be provided in the rescue and fire fighting vehicles, should be maintained on the aerodrome for vehicle replenishment purposes. Where a major delay in the replenishment of this supply is anticipated, the amount of reserve supply should be increased.~~

9.2.21A Recommendation.— A reserve supply of foam concentrate, equivalent to 200 per cent of the quantities identified in Table 9-2, should be maintained on the aerodrome for vehicle replenishment purposes.

Note.— Foam concentrate carried on fire vehicles in excess of the quantity identified in Table 9-2 can contribute to the reserve.

9.2.21B Recommendation.— A reserve supply of complementary agent, equivalent to 100 per cent of the quantity identified in Table 9-2, should be maintained on the aerodrome for vehicle replenishment purposes. Sufficient propellant gas should be included to utilize this reserve complementary agent.

9.2.21C Recommendation.— Category 1 and 2 aerodromes that have replaced up to 100 per cent of the water with complementary agent should hold a reserve supply of complementary agent of 200 per cent.

9.2.21D Recommendation.— Where a major delay in the replenishment of the supplies is anticipated, the amount of reserve supply in 9.2.19A, 9.2.19B and 9.2.19C should be increased as determined by a risk assessment.

Note.— See Airport Services Manual (Doc 9137), Part 1 for guidance on the conduct of a risk analysis to determine the quantities of reserve extinguishing agents.

Rationale

Current reserve requirement is ambiguous as the quantities of agents to be provided in the vehicles can be based on either the Standard in 9.2.13 or the Recommendation in 9.2.14. Additionally, the quantities of reserve agent should be based on the actual quantities required as per Table 9-2, irrespective of the number of vehicles to be provided so that States and operators are not penalised should they provide vehicles over and above that required by 9.2.37.

...

Response time

...

9.2.23 The operational objective of the rescue and fire fighting service shall be to achieve a response time not exceeding three minutes to any point of each operational runway, in optimum visibility and

surface conditions.

...

Personnel

...

9.2.40 **Recommendation.**— *During flight operations, sufficient ~~trained~~ competent personnel should be ~~detailed~~ designated and to be readily available to ride the rescue and fire fighting vehicles and to operate the equipment at maximum capacity. These ~~trained~~ personnel should be deployed in a way that ensures that minimum response times can be achieved and that continuous agent application at the appropriate rate(s) can be fully maintained. Consideration should also be given for personnel to use hand lines, ladders and other rescue and fire fighting equipment normally associated with aircraft rescue and fire fighting operations.*

9.2.41 **Recommendation.**— *In determining the minimum number of rescue and fire fighting personnel required, ~~to provide for rescue, consideration should be given to the types of aircraft using the aerodrome~~ a task resource analysis should be completed and the level of staffing promulgated in, or reference to, the Aerodrome Manual.*

Note: - Guidance on the use of a task resource analysis can be found in the Airport Services Manual, Part I.

Rationale

The essence of the proposed changes goes back to the perceived need to establish the competence of fire fighters and how the levels of staffing were to be achieved and documented in order that the minimum response times and continuous agent application at the appropriate rate/s could be fully achieved and maintained.

There is currently no SARP or guidance for the establishment of staffing numbers for a RFF service. The proposed amendments to Annex 14 Volume I paragraphs 9.2.40 and 9.2.41 will be supported by detailed guidance in the Airport Services Manual Part 1.

...

9.9 Siting of equipment and installations on operational areas

Note 1.— Requirements for obstacle limitation surfaces are specified in 4.2.

Note 2.— The design of light fixtures and their supporting structures, light units of visual approach slope indicators, signs, and markers, is specified in 5.3.1, 5.3.5, 5.4.1 and 5.5.1, respectively. Guidance on the frangible design of visual and non-visual aids for navigation is given in the Aerodrome Design Manual (Doc 9157), Part 6.

9.9.1 Unless its function requires it to be there for air navigation or for aircraft safety purposes, no equipment or installation shall be:

- a) on a runway strip, a runway end safety area, a taxiway strip or within the distances specified in Table 3-1, column 11, if it would endanger an aircraft; or
- b) on a clearway if it would endanger an aircraft in the air.

9.9.2 Any equipment or installation required for air navigation or for aircraft safety purposes which must be located:

- a) on that portion of a runway strip within:
 - 1) 75 m of the runway centre line where the code number is 3 or 4; or
 - 2) 45 m of the runway centre line where the code number is 1 or 2; or
- b) on a runway end safety area, a taxiway strip or within the distances specified in Table 3-1; or
- c) on a clearway and which would endanger an aircraft in the air;

shall be frangible and mounted as low as possible.

9.9.3 Existing non-visual aids need not meet the requirement of 9.9.2 until 1 January 2010.

9.9.4 **Recommendation.**— *Any equipment or installation required for air navigation or for aircraft safety purposes which must be located on the non-graded portion of a runway strip should be regarded as an obstacle and should be frangible and mounted as low as possible.*

Note.— Guidance on the siting of navigation aids is contained in the Aerodrome Design Manual (Doc 9157), Part 6.

9.9.5 Unless its function requires it to be there for air navigation or for aircraft safety purposes, no equipment or installation shall be located within 240 m from the end of the strip and within:

- a) 60 m of the extended centre line where the code number is 3 or 4; or
- b) 45 m of the extended centre line where the code number is 1 or 2;

of a precision approach runway category I, II or III.

9.9.6 Any equipment or installation required for air navigation or for aircraft safety purposes which must be located on or near a strip of a precision approach runway category I, II or III and which:

- a) is situated on that portion of the strip within 77.5 m of the runway centre line where the code number is 4 and the code letter is F; or
- b) is situated within 240 m from the end of the strip and within:
 - 1) 60 m of the extended runway centre line where the code number is 3 or 4; or
 - 2) 45 m of the extended runway centre line where the code number is 1 or 2; or
- c) penetrates the inner approach surface, the inner transitional surface or the balked landing surface;

shall be frangible and mounted as low as possible.

9.9.7 Existing non-visual aids need not meet the requirement of 9.9.6 b) until 1 January 2010.

Note.— See 5.3.1.5 for the protection date for existing elevated approach lights.

9.9.8 **Recommendation.**— Any equipment or installation required for air navigation or for aircraft safety purposes which is an obstacle of operational significance in accordance with 4.2.4, 4.2.11, 4.2.20 or 4.2.27 should be frangible and mounted as low as possible.

Rationale

The amendments to SARPs regarding the siting of equipment and installations on operational areas are required to support the installation of arresting systems which are frangible and intended to enhance safety in the event of an aircraft overrun.

CHAPTER 10. AERODROME MAINTENANCE

10.1 General

10.1.1 **Recommendation.**— A maintenance programme, including preventive maintenance where appropriate, ~~should~~ shall be established at an aerodrome to maintain facilities ~~in a condition which does not impair the safety, regularity or efficiency of air navigation~~ such as pavements, visual aids, fencing and drainage systems in a condition which does not impair the safety, regularity or efficiency of air navigation.

Note 1.— Preventive maintenance is programmed maintenance work done in order to prevent a failure or degradation of facilities.

Note 2.— “Facilities” are intended to include such items as pavements, visual aids, fencing, drainage systems and buildings.

Rationale

The proposal to strengthen existing paragraph 10.1.1 places emphasis on the importance of maintenance in the provision of safe, regular and efficient facilities for air navigation. As aerodromes become increasingly privatised, the new Standard ensures sufficient resources are being allocated to the oft-neglected domain of maintenance. This proposal to upgrade paragraph 10.1.1 to a Standard is also consistent with other SARPs such as, but not limited to, existing paragraphs 10.2.2, 10.2.4 and other amendments being proposed dealing with maintenance which are, by themselves, Standards.

10.1.2 Recommendation.— *The design and application of the maintenance programme should observe Human Factors principles.*

Note.— *Guidance material on Human Factors principles can be found in the Human Factors Training Manual (Doc 9683) and in the Airport Services Manual (Doc 9137), Part 8.*

10.2 Pavements

10.2.1 The surfaces of all movement areas including pavements (runways, taxiways and aprons) and adjacent areas shall be inspected and their conditions monitored regularly as part of an aerodrome preventive and corrective maintenance programme with the objective of avoiding and eliminating any loose objects/debris that might cause damage to aircraft or impair the operation of aircraft systems.

Note 1.— *See 2.9.3 for inspections of movement areas.*

Note 2.— *Guidance on carrying out daily inspections of the movement area is given in the Airport Services Manual (Doc 9137), Part 8, the Manual of Surface Movement Guidance and Control Systems (SMGCS) (Doc 9476) and the Advanced Surface Movement Guidance and Control Systems (A-SMGCS) Manual (Doc 9830).*

Note 3.— *Additional guidance on sweeping/cleaning of surfaces is contained in the Airport Services Manual (Doc 9137), Part 9.*

Note 4.— *Guidance on precautions to be taken in regard to the surface of shoulders is given in Attachment A, Section 8, and the Aerodrome Design Manual (Doc 9157), Part 2.*

Note 5.— *Where the pavement is used by large aircraft or aircraft with high tire pressures in 2.6.6(c), particular attention should be given to the integrity of light fittings in the pavement and pavement joints.*

10.2.2 The surface of a runway shall be maintained in a condition such as to prevent formation of harmful irregularities.

Note.— *See Attachment A, Section 5.*

10.2.3 A paved runway shall be maintained in a condition so as to provide surface friction characteristics at or above the minimum friction level specified by the State.

Note.— *Guidance on determining and expressing the surface friction characteristics during snow or ice*

conditions is given in Attachment A, Section 6. The Airport Services Manual (Doc 9137), Part 2, contains further information on this subject, on improving surface friction characteristics and on clearing of runways

10.2.34 Measurements of the runway surface friction characteristics of a runway surface for maintenance purpose shall be made periodically with a continuous friction measuring device using self-wetting features and documented. The frequency of these measurements shall be sufficient to determine the trend of the surface friction characteristics of the runway.

Note 1.— Guidance on evaluating the friction characteristics of a runway is provided in Attachment A, Section 7. Additional guidance is included in the Airport Services Manual (Doc 9137), Part 2.

Note 2.— The objective of 10.2.3 to 10.2.6 is to ensure that the surface friction characteristics for the entire runway remain at or above a minimum friction level specified by the State.

Note 3.— Guidance for the determination of the required frequency is provided in Attachment A, Section 7 and in the Airport Services Manual (Doc 9137), Part 2, Appendix 5.

10.2.45 Corrective maintenance action shall be taken to prevent the runway surface ~~when the~~ friction characteristics for either the entire runway or a portion thereof ~~are~~ from falling below a minimum friction level specified by the State.

Note.— A portion of runway in the order of 100 m long may be considered significant for maintenance or reporting action.

~~10.2.5 **Recommendation.**— Corrective maintenance action should be considered when the friction characteristics for either the entire runway or a portion thereof are below a maintenance planning level specified by the State.~~

Rationale:

The new paragraph 10.2.3, which is performance-based, contains part of the existing 10.2.8 and is relocated here, for consistency. The remaining part of existing paragraph 10.2.8, dealing with the removal of contaminants, has been re-designated as paragraph 10.3.1 and placed in a new section 10.3.

While a similar provision in Chapter 3 deals with design and construction aspects, the prime objective of the proposed amendments here is to ensure that the surface friction characteristics of the runway is maintained at or above a minimum friction level specified by the State. Amendment proposed to existing paragraph 10.2.3 (re-numbered 10.2.4) establishes the control of the surface friction characteristics for maintenance purpose through measurements at a suitable frequency, with reference to the availability of appropriate guidance material in the Notes.

The proposed amendment to existing paragraph 10.2.4 (re-numbered 10.2.5) seeks to require a corrective maintenance action before a portion of a runway falls below the minimum friction level (MFL).

The Recommended Practice in existing paragraph 10.2.5 is now proposed to be deleted since the upgraded paragraph 10.1.1 and the re-numbered paragraph 10.2.5 adequately capture the intent of the safety requirement. This implies the aerodrome operator defines a mandatory maintenance programme, including preventive maintenance, as stipulated in paragraph 10.1.1, which may utilize the concept of Maintenance Planning Level (MPL). The use of a MPL to establish a maintenance programme can be proposed as guidance but is not seen as appropriate for a SARP, as it relates more to economic considerations rather than safety.

10.2.6 Recommendation.— *When there is reason to believe that the drainage characteristics of a runway, or portions thereof, are poor due to slopes or depressions, then the runway surface friction characteristics should be assessed under natural or simulated conditions that are representative of local rain, and corrective maintenance action should be taken as necessary.*

10.2.7 Recommendation.— *When a taxiway is used by turbine-engined aeroplanes, the surface of the taxiway shoulders should be maintained so as to be free of any loose stones or other objects that could be ingested by the aeroplane engines.*

Note.— *Guidance on this subject is given in the Aerodrome Design Manual (Doc 9157), Part 2.*

(new section) **10.3 Removal of contaminants**

~~10.2.8~~ **10.3.1** ~~The surface of a paved runway shall be maintained in a condition so as to provide good friction characteristics and low rolling resistance. Snow, slush, ice, standing water, mud, dust, sand, oil, rubber deposits and other contaminants shall be removed from the surface of a paved runway as rapidly and completely as possible to minimize accumulation.~~

~~*Note.*— *Guidance on determining and expressing the friction characteristics when conditions of snow or*~~

~~ice cannot be avoided is given in Attachment A, Section 6. The Airport Services Manual (Doc 9137), Part 2, contains further information on this subject, on improving friction characteristics and on clearing of runways. The above requirement does not imply that winter operations on compacted snow and ice are prohibited. Guidance on snow removal and ice control is given in the Aerodrome Design Manual (Doc 9157), Part 2, Chapter 7.~~

~~10.2.9~~ **10.3.2 Recommendation.**— ~~A~~ **Taxiways** should be kept clear of snow, slush, ice, etc., to the extent necessary to enable aircraft to be taxied to and from an operational runway.

~~10.2.10~~ **10.3.3 Recommendation.**— Aprons should be kept clear of snow, slush, ice, etc., to the extent necessary to enable aircraft to manoeuvre safely or, where appropriate, to be towed or pushed.

~~10.2.11~~ **10.3.4 Recommendation.**— Whenever the clearance of snow, slush, ice, etc., from the various parts of the movement area cannot be carried out simultaneously, the order of priority after the runway(s) in use should be set in ~~as follows but may be altered following, as necessary,~~ consultation with the aerodrome users ~~and other interested parties:~~

~~1st — runway(s) in use;~~

~~2nd — taxiways serving runway(s) in use;~~

~~3rd — apron(s);~~

~~4th — holding bays; and~~

~~5th — other areas.~~

....

Rationale

Given the importance of proper management of surface contaminants and its impact on aircraft safety, it is felt necessary to establish a new section germane to the removal of contaminants vis-à-vis other aspects of maintenance since the former is perceived to be of a more operational nature.

The amendment proposed to existing paragraph 10.2.11 (re-numbered 10.3.4) concerning the priority for the removal of contaminants after the runway in use is performance-based and provides flexibility to take into account local conditions which were hitherto not considered, but nevertheless vital, such as the need to remove contaminants such as snow and ice from ingress and egress routes of aerodrome rescue and fire fighting stations.

10.3.4 Runway pavement overlays

Note.— The following specifications are intended for runway pavement overlay projects when the runway is to be returned temporarily to an operational status before ~~overlay of the entire runway~~ resurfacing is complete. ~~this normally~~ This may necessitate ~~ing~~ a temporary ramp between the new and old runway surfaces. Guidance on overlaying pavements and assessing their operational status is given in the Aerodrome Design Manual (Doc 9157), Part 3.

~~10.3.1~~ **10.4.1** The longitudinal slope of the temporary ramp, measured with reference to the existing runway surface or previous overlay course, shall be:

- a) 0.5 to 1.0 per cent for overlays up to and including 5 cm in thickness; and
- b) not more than 0.5 per cent for overlays more than 5 cm in thickness.

....

Editorial Note.— Renumber subsequent paragraphs accordingly.

...

10.4.5 Recommendation.— *The overlay should be constructed and maintained above the minimum friction level specified in 10.2.3.*

Editorial Note.— Renumber subsequent paragraphs accordingly.

Rationale:

The amendment proposed in this section is driven primarily by two serious accidents that occurred in one State where the friction characteristics of the temporary runway surface undergoing re-surfacing and re-profiling work was found to be wanting. The reduced friction on the wet base course sections of the runway caused flight crews to experience reduced braking action and reduced lateral controllability on landing in strong crosswinds.

The recommendation in the new paragraph 10.4.5 has been introduced to ensure consistency of the pavement maintenance actions requiring overlays with the provision specified in the new paragraph 10.2.3.

10.4 **5** Visual aids

Note 1. — *These specifications are intended to define the maintenance performance level objectives. They are not intended to define whether the lighting system is operationally out of service.*

Note 2.- The energy savings of light emitting diodes (LEDs) are due in large part to the fact that they do not produce the infra-red heat signature of incandescent lamps. Aerodrome operators who have come to expect the melting of ice and snow by this heat signature may wish to evaluate whether or not a modified maintenance schedule is required during such conditions, or evaluate the possible operational value of installing LED fixtures with heating elements.

Note 3.- Enhanced vision systems (EVS) technology relies on the infra-red heat signature provided by incandescent lighting. Annex 15 protocols provide an appropriate means of notifying aerodrome users of

EVS when lighting systems are converted to LED.

Rationale

It is considered appropriate to include a note to advise readers that the loss of infra-red signature when converting from incandescent to LED technology eliminates the snow and ice melting capability of lamps and has deleterious effects on the use of enhanced vision systems. It is also proposed that readers should be advised that the change to LED technology is considered as constituting a NOTAM and AIP item per existing requirements of Annex 15.

ATTACHMENT A. GUIDANCE MATERIAL SUPPLEMENTARY TO ANNEX 14, VOLUME I

6.—~~Determining and expressing~~ Assessing the surface friction characteristics of snow—~~and~~—, slush-, ice- and frost-covered paved surfaces

———6.1—— There is an operational need for reliable and uniform information concerning the friction surface condition of contaminated runways. Contaminant type, distribution and for loose contaminants, depth are assessed for each third of the runway. An indication of surface friction characteristics of ice and snow covered runways. Accurate and reliable indications of surface friction characteristics is helpful in conducting runway condition assessment. It can be obtained by friction measuring devices; however, further experience is required there is no international consensus on the ability to correlate the results obtained by such equipment directly with aircraft performance, owing.

6.2 Any friction measuring device intended to the many variables involved, such as: predict aircraft mass, speed, braking mechanism, tire and undercarriage characteristics performance according to an agreed local or national procedure should be shown to correlate such performance in a manner acceptable to the State. Information on the practice of one State providing correlation directly with aircraft braking performance can be found in the *ICAO Circular 329 Runway Surface Condition Assessment, Measurement and Reporting, Appendix A*.

———6.2—3 The friction coefficient should be measured if a runway is covered wholly or partly by snow or ice and repeated as conditions change. Friction measurements and/or braking action assessments on surfaces other than runways should be made when an unsatisfactory friction condition of a runway can be expected on such surfaces.

———6.3—— The measurement of the friction coefficient provides the best basis for determining assessed in descriptive terms of “estimated surface friction conditions.” The value of estimated surface friction should be the maximum value which occurs when a wheel is slipping but still rolling. Various friction measuring devices may be used. As there is an operational need for uniformity in the method of assessing and reporting runway friction conditions, the measurements should preferably be made with equipment which provides continuous measuring of the maximum friction along the entire runway. Measuring techniques and information on limitations of the various friction measuring devices and precautions to be observed are given is categorized as good, medium to good, medium, medium to poor, and poor, and

promulgated in the *Airport Services Manual* (Doc 9137), Part 2.

6.4 A chart, based on results of tests conducted on selected ice or snow covered surfaces, showing the correlation between certain friction measuring devices on ice or snow covered surfaces is presented in the *Airport Services Manual* (Doc 9137), Part 2.

Note. This criteria addresses single event roughness, not long wavelength harmonic effects nor the effect of repetitive surface undulations.

6.5 The friction conditions of a runway should be expressed as “braking action information” in terms of the measured friction coefficient μ or estimated braking action. Specific numerical μ values are necessarily related to the design and construction of each friction measuring device Annex 15, Appendix 2-SNOWTAM format as well as to the surface being measured and the speed employed in PANS-ATM, Chapter 12.3-ATC phraseologies.

6.6 The table below with associated descriptive terms was developed from friction data collected only in compacted snow and ice and should not therefore be taken to be absolute values applicable in all conditions. If the surface is affected by snow or ice and the braking action estimated surface friction is reported as “good”, pilots should not expect to find conditions as good as on a clean dry runway (where the available friction may well be greater than that needed in any case). The value “good” is a comparative value and is intended to mean that aeroplanes should not experience directional control or braking difficulties, especially when landing. The figures in the “Measured Coefficient μ ” column are given as an indication. At each aerodrome a specific table can be developed according to the measuring device used on the aerodrome and according to the standard and correlation criteria set or agreed by the State. The μ values given are specific to each friction measuring device as well as to the surface being measured and the speed employed.

<i>Measured coefficient</i>	<i>Estimated braking action</i>	<i>Code</i>
0.40 and above	Good	5
0.39 to 0.36	Medium to good	4
0.35 to 0.30	Medium	3
0.29 to 0.26	Medium to poor	2
0.25 and below	Poor	1

6.7 It has been found necessary to provide surface friction information

<i>Measured Coefficient μ</i>	<i>Estimated surface friction</i>	<i>Code</i>
0.40 and above	Good	5
0.39 to 0.36	Medium to good	4
0.35 to 0.30	Medium	3
0.29 to 0.26	Medium to poor	2
0.25 and below	Poor	1

6.5 It has been elusive trying to relate braking action to friction measurements over the years. The main reason is that the industry to date has not achieved the ability to control the total uncertainty associated with the readings from these devices. Consequently, readings from a friction measuring device

should only be used as part of an overall runway condition assessment. A major difference between the decelerometer type of devices and the other types is that when using the decelerometer type the operator is an integrated part of the measuring process. In addition to carrying out the measurement, the operator can feel the behavior of the vehicle where the decelerometer is installed and by that feel the deceleration process. This gives additional information in the total assessment process.

6.6 It has been found necessary to provide assessed surface condition information, including estimated surface friction, for each third of a runway. The thirds are called A, B and C. For the purpose of reporting information to aeronautical service units, section A is always the section associated with the lower runway designation number. When giving landing information to a pilot before landing, the sections are however referred to as first, second or third part of the runway. The first part always means the first third of the runway as seen in the direction of landing. Friction measurements Assessments are made along two lines parallel to the runway, i.e. along a line on each side of the centre line approximately 3 m, or that distance from the centre line at which most operations take place. The objective of the tests assessment is to determine the mean type, depth and coverage of the contaminants and its effect on estimated surface friction value, given the prevailing weather conditions for sections A, B and C. In cases where a continuous friction measuring device is used, the mean values are obtained from the friction values recorded for each section. The distance between each test point should be approximately 10 per cent of the usable length of the runway. If it is decided that a single test line on one side of the runway centre line gives adequate coverage of the runway, then it follows that estimated surface friction, each third of the runway should have three tests carried out on it. Test results and calculated mean friction values are entered in a special form where achievable. Information collected and assessed on the state of pavement surface is disseminated using forms prepared by the State for SNOWTAM and NOTAM (see the *Airport Services Manual (Doc 9137) Part 2*).

————— *Note.* ——— Where applicable, figures for stopway friction value should also be made available on request.

————— 6.8 ——— A continuous friction measuring device (e.g. Skiddometer, Surface Friction Tester, Mu meter, Runway Friction Tester or GripTester), can be used for measuring the friction values for compacted snow- and ice covered runways. A decelerometer (e.g. Tapley Meter or Brakemeter — Dynamometer) may be used on certain surface conditions, e.g. compacted snow, ice and very thin layers of dry snow. Other friction measuring devices can be used, provided they have been correlated with at least one of the types mentioned above. A decelerometer should not be used in loose snow or slush, as it can give misleading friction values. Other friction measuring devices can also give misleading friction values under certain combinations of contaminants and air/pavement temperature.

————— 6.9 ——— 7 The *Airport Services Manual (Doc 9137)*, Part 2 provides guidance on the uniform use of test equipment to achieve compatible test results and other information on removal of surface contamination and improvement of friction conditions.

Rationale:

The existing texts are premised on the assumption that the friction characteristics of snow- and ice-covered paved surfaces could be determined with friction measurement using appropriate measuring devices. Although some States have developed, or are developing, a methodology and procedures to

predict aircraft braking performance, there are presently no internationally agreed methodology and procedures.

The proposed revision to Annex 14, Volume I, Attachment A, section 6 stems from the proposed amendments to Annex 14, Volume I, (new) paragraphs 2.9.7 and 2.9.8. It acknowledges a) the absence of internationally agreed methodology and procedures and b) the existence of proven or experimental national or regional methodology and procedures which requires friction measurement devices meet the standards set by the State when they are used for the assessment of the runway surface condition in order to ensure the quality and accuracy of the information reported.

7.—Determination of surface friction characteristics for construction and maintenance purposes of wet paved runways

The guidance in this section deals with the functional measurement of friction-related aspects related to runway construction and maintenance. Excluded in this section is the operational, as opposed to functional, measurement of friction for contaminated runways. However, the devices used for functional measurement could also be used for operational measurement, but in the latter case, the figures given in Airport Services Manual (Doc 9137), Part 2, Table 3-1 are not relevant.

7.1— The surface friction characteristics of a wet paved runway should be measured to:

- a) a) — assessed to verify the surface friction characteristics of new or resurfaced paved runways when wet (Chapter 3, 3.1.24); and
- b) b) — assessed periodically in order to determine the slipperiness of paved runways when wet (Chapter 10, 10.2.34);

— c) — determine the effect on friction when drainage characteristics are poor (Chapter 10, 10.7.2.6); and

— d) — determine the friction of paved runways that become slippery under unusual conditions (Chapter 2, 2.9.8).

— 7.2 — Runways should be evaluated when first constructed or after resurfacing to determine the wet runway surface friction characteristics. The condition of a runway pavement is generally assessed under dry conditions using a self wetting continuous friction measuring device. Evaluation tests of runway surface friction characteristics. Although it is recognized that friction reduces with use, this value will represent the friction of the relatively long central portion of the runway that is uncontaminated by rubber deposits from aircraft operations and is therefore of operational value. Evaluation tests should be made on clean surfaces. If it is not possible to clean a surface before testing, then for purposes of preparing an initial report a test could be made on a portion of clean surface in the central part of the runway of the runway when first constructed or after resurfacing.

— 7.3 — Friction tests of existing surface conditions should be taken periodically in order to identify runways with low friction when wet. A State should define what avoid falling below the minimum friction level it considers acceptable before a runway is classified as slippery when wet and publish this

value in the State's aeronautical information publication (AIP) specified by the State. When the friction of any portion of a runway is found to be below this reported minimum friction level value, then such information should be promulgated by in a NOTAM. The State should also establish a maintenance planning level, below specifying which, appropriate corrective maintenance action should be initiated to improve the friction. However, when the friction characteristics for either the entire runway or a portion thereof are portion of the runway is below the minimum friction level, and its location on the runway. A corrective maintenance action must be taken initiated without delay. Friction measurements should be taken at time intervals that will ensure the identification of runways in need of maintenance or of special surface treatment before their condition becomes serious. The time interval between intervals and mean frequency of measurements will depend on factors such as: aircraft type and frequency of usage, climatic conditions, pavement type, and pavement service and maintenance requirements.

7.4 For uniformity and to permit comparison with other runways, friction tests Friction measurements of existing, new or resurfaced runways should be made with a continuous friction measuring device provided with a smooth tread tire. The device should have a capability of using self-wetting features to enable allow measurements of the surface friction characteristics of the surface to be made at a water depth of at least 1 mm.

7.5 When it is suspected that the surface friction characteristics of a runway may be reduced because of poor drainage, owing to inadequate slopes or depressions, then an additional test should be measurement is made, but this time under natural conditions representative of a local rain. This test measurement differs from the previous one in that water depths in the poorly cleared areas are normally greater in a local rain condition. The test measurement results are thus more apt to identify problem areas having low friction values that could induce aquaplaning than the previous test. If circumstances do not permit tests measurements to be conducted during natural conditions representative of a rain, then this condition may be simulated. (See section 8)

7.6 Even when the friction has been found to be above the level set by the State to define a slippery runway, it may be known that under unusual conditions, such as after a long dry period, the runway may have become slippery. When such a condition is known to exist, then a friction measurement should be made as soon as it is suspected that the runway may have become slippery.

7.7 When the results of any of the measurements identified in 7.3 through 7.6 indicate that only a particular portion of a runway surface is slippery, then action to promulgate this information and, if appropriate, take corrective action is equally important.

7.8 7.6 When conducting friction tests on wet runways using a self wetting continuous friction measuring device, it is important to note that, unlike compacted snow and ice conditions, in which there is very limited variation of the friction coefficient with speed, a wet runway produces a drop in friction with an increase in speed. However, as the speed increases, the rate at which the friction is reduced becomes less. Among the factors affecting the friction coefficient between the tire and the runway surface, texture is particularly important. If the runway has a good macro-texture allowing the water to escape beneath the tire, then the friction value will be less affected by speed. Conversely, a low macro-texture surface will produce a larger drop in friction with increase in speed. Accordingly, when testing runways to determine their friction characteristics and whether maintenance action is necessary to improve it, a speed high enough to reveal these friction/speed variations should be used.

7.9 7 Annex 14, Volume I, requires States to specify two friction levels as follows:

- a) a maintenance minimum friction level below which corrective maintenance action should be initiated; and taken. As criteria for surface friction characteristics of new or resurfaced runway surfaces and its maintenance planning, the State can establish a maintenance planning level, below which appropriate corrective maintenance action should be initiated
- b) a minimum friction level below which information that a runway may be slippery when wet should be made available.

Furthermore, States should establish criteria for the friction characteristics of new or resurfaced runway surfaces. to improve the friction. Table A-1 The Airport Services Manual (Doc 9137), Part 2, provides guidance on establishing the design objective for new runway surfaces and maintenance planning and minimum friction levels for runway surfaces in use.

7.10 The friction values given above are absolute values and are intended to be applied without any tolerance. These values were developed from a research study conducted in a State. The two friction measuring tires mounted on the Mu meter were smooth tread and had a special rubber formulation, i.e. Type A. The tires were tested at a 15 degree included angle of alignment along the longitudinal axis of the trailer. The single friction measuring tires mounted on the Skiddometer, Surface Friction Tester, Runway Friction Tester and TATRA were smooth tread and used the same rubber formulation, i.e. Type B. The GripTester was tested with a single smooth tread tire having the same rubber formulation as Type B but the size was smaller, i.e. Type C. The specifications of these tires (i.e. Types A, B and C) are contained in the *Airport Services Manual (Doc 9137), Part 2*. Friction measuring devices using rubber formulation, tire tread/groove patterns, water depth, tire pressures, or test speeds different from those used in the programme described above, cannot be directly equated with the friction values given in the table. The values in columns (5), (6) and (7) are averaged values representative of the runway or significant portion thereof. It is considered desirable to test the friction characteristics of a paved runway at more than one speed.

Table A-1. Friction levels for new and existing runway surfaces

Test equipment	Test tire		Test speed (km/h)	Test water depth (mm)	Design objective for new surface	Maintenance planning level	Minimum friction level
	Type	Pressure (kPa)					
(1)	(2)	(3)	(4)	(5)	(6)	(7)	
Mu-meter Trailer	A	70	65	1.0	0.72	0.52	0.42
	A	70	95	1.0	0.66	0.38	0.26
Skiddometer Trailer	B	210	65	1.0	0.82	0.60	0.50
	B	210	95	1.0	0.74	0.47	0.34
Surface Friction Tester Trailer	B	210	65	1.0	0.82	0.60	0.50
	B	210	95	1.0	0.74	0.47	0.34
Runway Friction Tester Trailer	B	210	65	1.0	0.82	0.60	0.50
	B	210	95	1.0	0.74	0.54	0.41
TATRA Friction Tester Trailer	B	210	65	1.0	0.76	0.57	0.48
	B	210	95	1.0	0.67	0.52	0.42
GripTester Trailer	C	140	65	1.0	0.74	0.53	0.43
	C	140	95	1.0	0.64	0.36	0.24

~~7.11— Other friction measuring devices can be used, provided they have been correlated with at least one test equipment measurement device mentioned above. The Airport Services Manual (Doc 9137),, Part 2, provides guidance on the methodology for determining the friction values corresponding to the design objective, maintenance planning level and minimum friction level for a friction tester not identified in Table A-1.the above table.~~

<p><i>Origin:</i></p> <p><i>FTF/1 to 6</i></p> <p><i>AOSWG/5 to 8</i></p> <p><i>AP-WG/WHL-5 and 6</i></p>	<p><i>Rationale:</i></p> <p>The existing guidance gives rise to a possible confusion between functional friction measurement i.e. the friction measurements made for construction and maintenance purposes and operational friction measurement ie. the eventual friction measurements performed to assess the estimated surface friction on contaminated runways for operational use. The misuse of figures given in Table A-1 has contributed to at least two accidents in one State.</p> <p>The confusion is further compounded by the use of the operative word “should”, giving the misconception that the text is an extension of an Annex 14, Vol. I, Recommended Practice. The changes which are proposed aim at resolving this possible confusion by a) focusing on construction and maintenance aspects, b) removing parts of the guidance which are considered too detailed and c) using a more neutral wording which avoids the use of “should”.</p> <p>The FTF is cognizant that, subsequent to the development of Table A-1, tests performed by some States had revealed that the maintenance planning level (MPL) and minimum friction level (MFL) values indicated for the various test equipments might be obsolete and the correlation between them is therefore questioned. However a consensus for updated values cannot be achieved as, each friction measuring device indicated in Table A-1 is in fact representative of a type of device, meaning that another test device of the same type could give different measurements, even though it is of a same make. The table is, therefore, proposed to be deleted from Annex 14, Volume I, Attachment A. However, updated guidance can be found in Airport Services Manual (Doc 9137), Part 2.</p>
---	---

New section – incorporate Section 8 following paragraph 7.10 with the following.

8. Drainage characteristics of the movement area and adjacent areas

8.1 General

8.1.1 Rapid drainage of surface water is a primary safety consideration in the design, construction and maintenance of pavements and adjacent areas. The objective is to minimize water depth on the surface by

draining water off the runway in the shortest path possible and particularly out of the area of the wheel path. There are two distinct drainage processes taking place:

- a) natural drainage of the surface water from the top of the pavement surface until it reaches the final recipient such as rivers or other water bodies; and
- b) dynamic drainage of the surface water trapped under a moving tire until it reaches outside the tire-to-ground contact area.

8.1.2 Both processes can be controlled through:

- a) design;
- b) construction;and
- c) maintenance.

of the pavements in order to prevent accumulation of water on the pavement surface.

8.2 Design of pavement

8.2.1 Natural drainage is achieved through design of slopes on the various parts of the movement area allowing the surface water to flow away from the pavement to the recipient as surface water flow or through a sub surface drainage system. The resulting combined longitudinal and transverse slope is the path for the natural drainage runoff. This path can be shortened by adding transverse grooves.

8.2.2 Dynamic drainage is achieved through built-in texture in the pavement surface. The rolling tire builds up water pressure and squeezes the water out the escape channels provided by the texture. The dynamic drainage of the tire-to-ground contact area is improved by adding transverse grooves.

8.3 Construction of pavement

8.3.1 Through construction, the drainage characteristics of the surface are built into the pavement. These surface characteristics are:

- a) Slopes;
- b) Texture
 - i) Microtexture;
 - ii) Macrottexture;

8.3.2 Slopes for the various parts of the movement area and adjacent parts are described in Annex 14, Volume I, Chapter 3 and figures are given as per cent. Further guidance is given in Aerodrome Design Manual, Part 1, Runways, Chapter 5.

8.3.3 Texture in the literature is described as microtexture or macrottexture. These terms are understood differently in various part of the aviation industry.

8.3.4 Microtexture is the texture of the individual stones and is hardly detectable by the eye. Microtexture

is considered a primary component in skid resistance at slow speeds. On a wet surface at higher speeds a water film may prevent direct contact between the surface asperities and the tire due to insufficient drainage from the tire-to-ground contact area.

8.3.5 Microtexture is a built-in quality of the pavement surface. By specifying crushed material that will withstand polishing microtexture, drainage of thin waterfilms are ensured for a longer period of time. Resistance against polishing is expressed through the polished stone values, which are in principle a value obtained from a friction measurement in accordance with international standards .

8.3.6 A major problem with microtexture is that it can change within short time periods without being easily detected. A typical example of this is the accumulation of rubber deposits in the touchdown area which will largely mask microtexture without necessarily reducing macrotexture.

8.3.7 Macrotexture is the texture among the individual stones. This scale of texture may be judged approximately by the eye. Macrotexture is primarily created by the size of aggregate used or by surface treatment of the pavement. Macrotexture is the major factor influencing drainage capacity at high speeds.

8.3.8 The primary purpose of grooving a runway surface is to enhance surface drainage. Natural drainage can be slowed down by surface texture, but grooving can speed up the drainage by providing a shorter drainage path.

8.3.9 For measurement of macrotexture, simple methods such as the “sand and grease patch”- methods described in the *Airport Services Manual* (Doc 9137), Part 2 were developed. These methods were used for the early research on which current airworthiness requirements are based upon, which refer to a classification categorizing macrotexture from A to E. This classification was developed, using sand or grease patch measuring techniques, and issued in 1971 by the Engineering Sciences Data Unit (ESDU).

Runway classification based on texture information from ESDU 71026:

Classification	Texture depths (mm)
A	0.10 – 0.14
B	0.15 – 0.24
C	0.25 – 0.50
D	0.51 – 1.00
E	1.01 – 2.54

8.3.10 Using this classification the threshold value between microtexture and macrotexture is 0.1 mm mean texture depth (MTD). Related to this scale the normal wet aircraft performance is based upon texture giving drainage and friction qualities midway between classification B and C (0.25 mm) Improved drainage through better texture might qualify for a better aircraft performance class. However such credit must be in accordance with aeroplane manufacturers documentation and agreed by the State. Presently credit is given to grooved or porous friction course runways following design, construction and maintenance criteria acceptable to the State. The harmonized certification standards of some States refer to

texture giving drainage and friction qualities midway between classification D and E (1.0 mm)

8.3.11 For construction, design and maintenance, States use various international standards. Currently *ISO 13473-1: Characterization of pavement texture by use of surface profiles -- Part 1: Determination of Mean Profile Depth* links the volumetric measuring technique with non contact profile measuring techniques giving comparable texture values. These standards describe the threshold value between microtexture and macrotexture as 0.5 mm. The volumetric method has a validity range from 0.25 to 5 mm MTD. The profilometry method has a validity range from 0 to 5 mm mean profile depth (MPD). The values of MPD and MTD differ due to the finite size of the glass spheres used in the volumetric technique and because the MPD is derived from a two-dimensional profile rather than a three-dimensional surface. Therefore a transformation equation must be established for the measuring equipment used to relate MPD to MTD.

8.3.12 There is a standard describing drainage capacity by the use of an outflow meter measuring the horizontal drainage. This method has a validity range from 0 to 0.4 mm MPD and can for that reason only be used on smooth surfaces. This test method does not necessarily correlate with other methods of measuring pavement surface characteristics.

8.3.13 The ESDU scale groups runway surfaces based on macrotexture from A through E, where E represents the surface with best dynamic drainage capacity. The ESDU scale thus reflects the dynamic drainage characteristics of the pavement. Grooving any of these surfaces enhances the dynamic drainage capacity. The resulting drainage capacity of the surface is thus a function of the texture (A through E) and grooving. The contribution from grooving is a function of the size of the grooves and the spacing between the grooves. Aerodromes exposed to heavy or torrential rainfall must ensure that the pavement and adjacent areas have drainage capability to withstand these rainfalls or put limitations on the use of the pavements under such extreme situations. These airports should seek to have grooved pavements in the E classification to ensure that safety is not impaired.

8.4 Maintenance of drainage characteristics of pavement

8.4.1 Macrotexture does not change within a short timespan but accumulation of rubber can fill up the texture and as such reduce the drainage capacity, which can result in impaired safety. Furthermore the runway structure may change over time and give unevenness which results in ponding after rainfall. Guidance on rubber removal and unevenness can be found in *Airport Services Manual* (Doc 9137), Part 2. Guidance on methods for improving surface texture can be found in *Aerodrome Design Manual* (Doc 9157), Part 3.

Editorial Note.— Renumber subsequent paragraphs accordingly.

<i>Origin:</i> <i>FTF/1 to 6</i>	<i>Rationale:</i> Drainage performance of the movement area and of the adjacent areas is an essential element to minimize water depth on the pavement surface. The FTF proposes to
---	---

AOSWG/5 to 8 AP- WG/WHL-5 and 6	introduce a new section 8 entitled <i>Drainage characteristics of the movement area and adjacent areas</i> in Attachment A to Annex 14, Volume I in order to provide up-to-date guidance. Detailed guidance will be provided later with the planned update of Doc 9157, <i>Aerodrome Design Manual, Part 3 — Pavements</i> .
---	--

...

9. Runway end safety areas

9.1 Where a runway end safety area is provided in accordance with Chapter 3, consideration should be given to providing an area long enough to contain overruns and undershoots resulting from a reasonably probable combination of adverse operational factors. On a precision approach runway, the ILS localizer is normally the first upstanding obstacle, and the runway end safety area should extend up to this facility. In other circumstances and on a non-precision approach or non-instrument runway, the first upstanding obstacle may be a road, a railroad or other constructed or natural feature. In such circumstances, the runway end safety area should extend as far as the obstacle.

9.2 Where provision of a runway end safety area may involve encroachment in areas where it would be particularly prohibitive to implement, and the appropriate authority considers a runway end safety area essential, consideration may have to be given to reducing some of the declared distances.

9.3 Research programmes, as well as evaluation of actual aircraft overruns into arresting systems, have demonstrated that the performance of some arresting systems are predictable and effective in arresting aircraft overruns.

9.4 Demonstrated performance of an arresting system can be achieved by a validated design method, which can predict the performance of the system. The design and performance should be associated to that type of aircraft anticipated to use the associated runway that imposes the greatest demand upon the arresting system.

9.5 The design of an arresting system must consider multiple aircraft parameters, including but not limited to, allowable aircraft gear loads, gear configuration, tire contact pressure, aircraft center of gravity and aircraft speed. Additionally, the design must allow safe ingress and egress of fully loaded rescue and fire fighting vehicles.

9.6 The design of an arresting system must ensure that it will not endanger an aircraft undershooting the runway.

9.7 Additional information is contained in the Aerodrome Design Manual (*Doc 9157, Part 1*).

Rationale

The proposed new paragraphs in Section 9 of Attachment A introduce the use of arresting systems and provide guidance on principles to be followed in the design of an arresting system.

...

APPENDIX 1. COLOURS FOR AERONAUTICAL GROUND LIGHTS, MARKINGS, SIGNS AND PANELS

1. General

Introductory Note.— The following specifications define the chromaticity limits of colours to be used for aeronautical ground lights, markings, signs and panels. The specifications are in accord with the 1983 specifications of the International Commission on Illumination (CIE).

It is not possible to establish specifications for colours such that there is no possibility of confusion. For reasonably certain recognition, it is important that the eye illumination be well above the threshold of perception, that the colour not be greatly modified by selective atmospheric attenuations and that the observer's colour vision be adequate. There is also a risk of confusion of colour at an extremely high level of eye illumination such as may be obtained from a high-intensity source at very close range. Experience indicates that satisfactory recognition can be achieved if due attention is given to these factors

*The chromaticities are expressed in terms of the standard observer and coordinate system adopted by the International Commission on Illumination (CIE) at its Eighth Session at Cambridge, England, in 1931.**

2. Colours for aeronautical ground lights

2.1 Chromaticities

2.1.1 The chromaticities of aeronautical ground lights shall be within the following boundaries:

CIE Equations (see Figure A1-1):

a) Red

Purple boundary $y = 0.980 - x$
 Yellow boundary $y = 0.335$

b) Yellow

Red boundary $y = 0.382$
 White boundary $y = 0.790 - 0.667x$
 Green boundary $y = x - 0.120$

c) Green

Yellow boundary $x = 0.360 - 0.080y$
 White boundary $x = 0.650y$
 Blue boundary $y = 0.390 - 0.171x$

d) Blue
 Green boundary $y = 0.805x + 0.065$
 White boundary $y = 0.400 - x$
 Purple boundary $x = 0.600y + 0.133$

e) White
 Yellow boundary $x = 0.500$
 Blue boundary $x = 0.285$
 Green boundary $y = 0.440$
 and $y = 0.150 + 0.640x$
 Purple boundary $y = 0.050 + .750x$
 and $y = 0.382$

f) White (LED only)
 Yellow boundary $x = 0.440$
 Blue boundary $x = 0.320$
 Green boundary $y = 0.150 + 0.643x$
 Purple boundary $y = 0.050 + .757x$

fg) Variable white
 Yellow boundary $x = 0.255 + 0.750y$
 and $x = 1.185 - 1.500y$
 Blue boundary $x = 0.285$
 Green boundary $y = 0.440$
 and $y = 0.150 + 0.640x$
 Purple boundary $y = 0.050 + 0.750x$
 and $y = 0.382$

Note.— Guidance on chromaticity changes resulting from the effect of temperature on filtering elements is given in the Aerodrome Design Manual (Doc 9157), Part 4.

Rationale

For LEDs, the white boundaries need to be redefined independently of the color limitations of incandescent light sources to better coincide with the colors that people identify as white, thereby removing any unnecessary restrictions that limit LED or other new light sources from being considered. Research was performed that investigated the region, or boundaries, in chromaticity space that define what people naturally identify as white in the context as described by the current standards. A range of test sources were evaluated having chromaticity points both within and outside the current aviation white boundaries. From these evaluations, the objective was to develop recommendations for aviation white boundaries that can include newer LED technology.

Editorial Note.— The following proposals are for Annex 14, Volume I, Appendix 2.

APPENDIX 2. AERONAUTICAL GROUND LIGHT CHARACTERISTICS

...

Figure A2-12. Isocandela diagram for taxiway centre line (15 m spacing), no-entry bar and stop bar lights in straight sections intended for use in runway visual range conditions of less than a value of 350 m where large offsets can occur and for low-intensity runway guard lights, Configuration B

Figure A2-13. Isocandela diagram for taxiway centre line (15 m spacing), no-entry bar and stop bar lights in straight sections intended for use in runway visual range conditions of less than a value of 350 m

Figure A2-14. Isocandela diagram for taxiway centre line (7.5 m spacing), no-entry bar and stop bar lights in curved sections intended for use in runway visual range conditions of less than a value of 350 m

Figure A2-15. Isocandela diagram for taxiway centre line (30 m, 60 m spacing), no-entry bar and stop bar lights in straight sections intended for use in runway visual range conditions of 350 m or greater

Figure A2-16. Isocandela diagram for taxiway centre line (7.5 m, 15 m, 30 m spacing), no-entry bar and stop bar lights in curved sections intended for use in runway visual range conditions of 350 m or greater

Figure A2-17. Isocandela diagram for high-intensity taxiway centre line (15 m spacing), no-entry bar and stop bar lights in straight sections intended for use in an advanced surface movement guidance and control system where higher light intensities are required and where large offsets can occur

Figure A2-18. Isocandela diagram for high-intensity taxiway centre line (15 m spacing), no-entry bar and stop bar lights in straight sections intended for use in an advanced surface movement guidance and control system where higher light intensities are required

Figure A2-19. Isocandela diagram for high-intensity taxiway centre line (7.5 m spacing), no-entry bar and stop bar lights in curved sections intended for use in an advanced surface movement guidance and control system where higher light intensities are required

Rationale

These amendments are proposed in support of the introduction of the no-entry bar presented in the proposed paragraph 5.3.19.6.

ATTACHMENT B to State letter AN 4/1.1.52-11/41

PROPOSED AMENDMENT TO
INTERNATIONAL STANDARDS
AND RECOMMENDED PRACTICES
AERONAUTICAL INFORMATION SERVICES
ANNEX 15
TO THE CONVENTION ON INTERNATIONAL CIVIL AVIATION

PROPOSED AMENDMENT TO

Annex 15 — Aeronautical Information Services

NOTES ON THE PRESENTATION OF THE PROPOSED AMENDMENT

The text of the amendment is arranged to show deleted text with a line through it and new text highlighted with grey shading, as shown below:

1.

- | | |
|---|-----------------------------------|
| 1. Text to be deleted is shown with a line through it. | text to be deleted |
| 2. New text to be inserted is highlighted with grey shading. | new text to be inserted |
| 3. Text to be deleted is shown with a line through it followed by the replacement text which is highlighted with grey shading. | new text to replace existing text |

Annex 15 — Aeronautical Information Services

**APPENDIX 1. CONTENTS OF
AERONAUTICAL INFORMATION PUBLICATION (AIP)**

(see Chapter 4)

PART 1 — GENERAL (GEN)

...

PART 2 — EN-ROUTE (ENR)

...

PART 3 — AERODROMES (AD)

**AD 1. AERODROMES/HELIPORTS —
INTRODUCTION**

**AD 1.1 Aerodrome/heliport
availability**

Brief description of the State's designated authority responsible for aerodromes and heliports, including:

- 1) the general conditions under which aerodromes/heliports and associated facilities are available for use;
- 2) a statement concerning the ICAO documents on which the services are based and a reference to the AIP location where differences, if any, are listed;
- 3) regulations, if any, concerning civil use of military air bases;
- 4) the general conditions under which the low visibility procedures applicable to Cat II/III operations at aerodromes, if any, are applied; and
- ~~5) friction measuring device used and the runway friction level below which the State will declare the runway to be slippery when wet; and~~
- 6) other information of a similar nature.

<p><i>Origin:</i></p> <p><i>FTF/1 to 5</i></p> <p><i>AOSWG/5 to 8</i></p> <p><i>AP-WG/WHL-5 and 6</i></p>	<p><i>Rationale:</i></p> <p>The proposed amendment recognizes that the use of a friction measuring device is not the sole means to assess the runway surface friction characteristics. In addition, as each aerodrome operator can use a friction measuring device provided its performance meet the standard and correlation criteria set or agreed by the State (see requirement in new paragraph 2.9.8, Annex 14, Volume I), this device may differ from the one which the State may use as a reference or for its own inspections. The promulgation of this information is misleading and has proved being a contributing factor to accidents. Furthermore, the existing sub-paragraph 5) did not specify whether the friction measuring device was used for maintenance or operational purposes. The information required in sub-paragraph 5) above was, at best, incomplete for its intended use, and at worse, misleading; hence its proposed deletion.</p>
---	--

INSTRUCTIONS FOR THE COMPLETION OF THE SNOWTAM FORMAT

...

9. *Item H* — ~~Friction measurements on each third of the run way and friction measuring device. Measured or calculated coefficient (two digits) or, if not available, eEstimated surface friction on each third of the runway (single digit) in the order from the threshold having the lower runway designation number. Insert a code 9 when surface conditions or available friction measuring device do not permit a reliable surface friction measurement to be made. Use the following abbreviations to indicate the type of friction measuring device used:~~

- ~~— BRD — Brakemeter Dynamometer~~
- ~~— GRT — Grip tester~~
- ~~— MUM — Mu meter~~
- ~~— RFT — Runway friction tester~~
- ~~— SFH — Surface friction tester (high pressure tire)~~
- ~~— SFL — Surface friction tester (low pressure tire)~~
- ~~— SKH — Skiddometer (high pressure tire)~~
- ~~— SKL — Skiddometer (low pressure tire)~~
- ~~— TAP — Tapley meter~~

~~If other equipment is used, specify in plain language.~~

Friction measurement devices can be used as part of the overall runway surface assessment. Some States may have developed procedures for runway surface assessment which may include the use of information obtained from friction measuring devices and the reporting of quantitative values. In such cases, these procedures should be published in the AIP and the reporting made in Item (T) of the SNOWTAM format.

<p><i>Origin:</i></p> <p><i>FTF/1 to 5</i></p> <p><i>AOSWG/5to 8</i></p> <p><i>AP-WG/WHL-5 and 6</i></p>	<p><i>Rationale:</i></p> <p>The assessment of the runway surface friction characteristics for operations relies on a variety and combination of factors which depend on local conditions. The friction measurements which are made for maintenance or, under specific conditions, operational uses, are not the sole means to assess the surface friction characteristics. Information required by pilots includes, inter alia, an assessment and report of the runway surface conditions and estimated braking action. Such data was needed by pilots when preparing a flight and before landing and take-off. The notion of friction measurements should therefore be replaced by the notion of surface conditions assessment. The use of devices to measure friction coefficient was a part of the means for a total assessment of the runway surface condition as the determination of the contaminant (such as amount of contaminant expressed as a percentage of surface contaminated) and the type and texture of the runway surface.</p>
--	--

	<p>The braking action of a specific aircraft on a runway surface results from a combination of various factors, inter alia: pavement surface friction characteristics, depth and type of contaminants, tire surface and layout, landing gear design, tire pressure. The aerodrome operator is only able to assess and report on the ground factors, including an estimated runway surface friction, and the pilots have to make their judgment on the estimated braking action on the basis of this information and of their operating manual. This is the reason why the term “estimated braking action” is to be replaced by “estimated surface friction” in the SNOWTAM format as well as in the ATC phraseology for aerodrome information.</p> <p>Specific competence is required for a proper understanding of the science of friction measurement which depends on, among others, the type of equipment used, its calibration and operating methods including a good understanding of local conditions. In certain cases, the provision of specific measured friction values has proved to be misleading and has contributed to accidents; hence the proposed amendment to paragraph 9, sub-item <i>H</i>, Annex 15, Appendix 2.</p>
--	--

ATTACHMENT C to State letter AN 4/1.1.52-11/41

**TEXT OF THE
PROPOSED AMENDMENT TO**

Procedures for Air Navigation Services — Air Traffic Management (PANS-ATM, Doc 4444)

NOTES ON THE PRESENTATION OF THE PROPOSED AMENDMENT

The text of the amendment is arranged to show deleted text with a line through it and new text highlighted with grey shading, as shown below:

1. ~~Text to be deleted is shown with a line through it.~~ text to be deleted
2. **New text to be inserted is highlighted with grey shading.** new text to be inserted
3. ~~Text to be deleted is shown with a line through it~~ followed by the **replacement text which is highlighted with grey shading.** new text to replace existing text

Chapter 12

PHRASEOLOGIES

....

12.3 ATC PHRASEOLOGIES

12.3.1 General

....

12.3.1.10 AERODROME INFORMATION

- | |
|--|
| <p>a) [(location)] RUNWAY SURFACE CONDITION
RUNWAY (number) (condition);</p> <p>b) [(location)] RUNWAY SURFACE CONDITION
RUNWAY (number) NOT CURRENT;</p> <p>c) LANDING SURFACE (condition);</p> <p>d) CAUTION CONSTRUCTION WORK (location);</p> <p>e) CAUTION (specify reasons) RIGHT (or LEFT), (or BOTH SIDES) OF RUNWAY [number];</p> <p>f) CAUTION WORK IN PROGRESS (or OBSTRUCTION) (position and any necessary advice);</p> <p>g) RUNWAY REPORT AT (observation time) RUNWAY (number) (type of precipitant) UP TO (depth of deposit) MILLIMETRES. BRAKING ACTION ESTIMATED SURFACE FRICTION GOOD (or MEDIUM TO GOOD, or MEDIUM, or MEDIUM TO POOR, or POOR or UNRELIABLE) [and/or BRAKING COEFFICIENT (equipment and number)];</p> <p>h) BRAKING ACTION REPORTED BY (aircraft type) AT (time) GOOD (or MEDIUM to GOOD, or MEDIUM, or MEDIUM to POOR, or POOR);</p> <p>i) BRAKING ACTION [(location)] (measuring equipment used), RUNWAY (number), TEMPERATURE [MINUS] (number), WAS (reading) AT (time);</p> |
|--|

- ji) RUNWAY (or TAXIWAY) (number) WET [or ~~DAMP, WATER PATCHES, FLOODED (depth)~~ **STANDING WATER**, or SNOW REMOVED (length and width as applicable), or TREATED, or COVERED WITH PATCHES OF DRY SNOW (or WET SNOW, or COMPACTED SNOW, or SLUSH, or FROZEN SLUSH, or ICE, or **WET ICE**, or ICE UNDERNEATH, or ICE AND SNOW, or SNOWDRIFTS, or FROZEN RUTS AND RIDGES)];
- kj) TOWER OBSERVES (weather information);
- kk) PILOT REPORTS (weather information).

<p><i>Origin:</i></p> <p><i>FTF/1 to 5</i></p> <p><i>AOSWG/5 to 8</i></p> <p><i>AP-WG/WHL-5 and 6</i></p>	<p><i>Rationale:</i></p> <p>The braking action of a specific aircraft on a runway surface results from a combination of various factors, <i>inter alia</i>, pavement surface friction characteristics, depth and type of contaminants, tire surface and layout, landing gear design and tire pressure. The aerodrome operator is only able to assess and report on the ground factors, including an estimated runway surface friction, and the pilots have to make their judgment on the estimated braking action on the basis of this information and of their operating manual. This is the reason why the term “estimated braking action” is to be replaced by “estimated surface friction” in the item g).</p> <p>In addition, the result of any assessment is the provision of an estimated qualitative surface friction level of the runway. With the present state-of-the-art technology, the correlation of friction levels with an estimated aircraft braking action is an inexact science as it depends on each aircraft and other operational factors; hence the proposed deletion of item i).</p>
---	---

RUNWAY END SAFETY AREAS

GUIDANCE ON MITIGATING MEASURES

This appendix includes guidance material for the ICAO Document Doc 9157 Part 1 - Aerodrome Design Manual.

1 To support the introduction of SARPs for states to consider alternative means to the recommended distance for RESA, guidance is necessary. Many factors can contribute to causing an overrun and the aim of this guidance is to identify what aerodrome activities can be undertaken to reducing the likelihood and consequences of an overrun occurring, and to decide on appropriate actions.

2 Whatever the length of RESA provided a study of data¹ on runway overruns suggest that the standard distance of 90m would capture approximately 61% of overruns, with 83% being contained within the recommended distance of 240m. Therefore, it is recognized that some overruns would exceed even beyond the 240m RESA distance. Accordingly, whatever length of RESA in excess of the Standard is provided it is important to ensure that the likelihood of and potential impacts arising from an overrun are minimized as far as reasonably practicable.

3 The overrun is a complex risk to assess because there are a number of variables, such as prevailing weather, type of aeroplane, the landing aids available, runway characteristics, the surrounding environment, and human factors. Each of these can have a significant contribution to the overall hazard; furthermore, the nature of the hazard and level of risk will be different for each aerodrome and even for each runway direction at any one aerodrome. The aerodrome may address some and these are included below. Additionally, aircraft operating procedures may impact but the aerodrome may have little ability to influence these. This should not prevent aerodromes from working with aircraft operators so that the operations are conducted so as to minimize the likelihood of an overrun occurring. An example of this might include measures to highlight to flight crews the presence of an arresting system and associated procedures.

4 When considering the RESA distance required for individual circumstances, aerodrome operators should take into account factors such as:

- a) the nature and location of any hazard beyond the runway end, including the topography and obstruction environment in and beyond the RESA and outside the runway strip;
- b) the type of aeroplane level of traffic at the aerodrome, and actual or proposed changes to either;
- c) friction and drainage characteristics of the runway, which impact on runway susceptibility to surface contamination and aeroplane braking action;
- d) navigation aids available (PBN, instrument or visual - if an ILS is only available on one runway direction, a downwind approach and landing may be necessary in poor weather);

¹ Source: ICAO ADREP database

- e) runway length and slope, in particular the general operating lengths required for take-off and landing versus the runway distances available, including the excess of available length over that required;
- f) options to provide additional land for RESA enhancement; and
- g) aerodrome weather patterns, including wind shear.

5 The following lists outline some of the measures that may be considered, singly or in combination, to reduce the risks of an overrun occurring or becoming an accident. Measures aimed at reducing the likelihood of an overrun/undershoot:

- a) improving runway surfaces and friction measurement, particularly when the runway is contaminated - know your runways and their condition and characteristics in precipitation;
- b) ensuring that accurate and up-to-date information on weather, the runway state and characteristics is notified and passed to flight crews in a timely way, particularly when flight crews need to make operational adjustments;
- c) improving an aerodrome management's knowledge, recording, prediction and dissemination of wind data, including wind shear, and any other relevant weather information, particularly when it is a significant feature of an aerodrome's weather pattern;
- d) upgrading visual and instrument landing aids to improve the accuracy of aeroplane delivery at the correct landing position on runways (including the provision of Instrument Landing PBN approach systems);
- e) formulating, in consultation with aeroplane operators, adverse weather and any other relevant aerodrome operating procedures or restrictions, and promulgating such information appropriately;

Measures intended to reduce the severity of the consequences should an event occur:

- f) reducing declared runway distances in order to provide the necessary RESA;
- g) installing suitably positioned and designed arresting systems, to supplement or as an alternative to a RESA where appropriate;
- h) increasing the length of a RESA, and/or minimizing the obstruction environment in the area beyond the RESA; and
- i) publishing the RESA and/or arresting systems provision in the AIP.

6 The above lists are not in any particular order, are not exhaustive and should complement action by aeroplane operators, designers and aviation regulators. Aerodrome operators are reminded of the need to advise the State aviation authority about changes to the physical characteristics of the aerodrome and that such changes are safely managed, in accordance with the aerodrome certification conditions.

Arresting Systems

7 In recent years the US Federal Aviation Administration (FAA) has undertaken research programs to evaluate and develop arresting systems using engineered materials (EMAS). This research was driven by the recognition that many runways, particularly those constructed prior to the adoption of increased RESA requirements introduced in 1999, where natural obstacles, local development, and/or environmental constraints, have limited potential for RESA. Additionally, there had been accidents at some of these airports where the ability to stop an overrunning aeroplane within the RESA would have prevented major damage to the aeroplane and/or injuries to passengers.

8 These research programs, as well as evaluation of actual aeroplane overruns into an EMAS installation, have demonstrated to the FAA that EMAS systems are effective in arresting aeroplane overruns, and they are now included in the FAA aerodrome requirements. The FAA performance specifications and requirements provide suitable information for aerodromes considering the installation of EMAS. Therefore, attention is drawn to the documents listed below which give guidance on the requirements and evaluation process used by the FAA.

- FAA Advisory Circular 150/5300-13 “Airport Design”;
- FAA Advisory Circular 150/5220-22A “Engineered Materials Arresting Systems (EMAS) for Aeroplane Overruns”;
- FAA Order 5200.8 “Runway Safety Area Program”;
- FAA Order 5200.9 “EMAS Financial Feasibility and Equivalency”.

9 The presence of an arresting system should be published in the aerodrome AIP entry and information/instructions promulgated to local runway safety teams and others to promote awareness in the pilot community.

ATTACHMENT E to State letter AN 4/1.1.52-11/41

RESPONSE FORM TO BE COMPLETED AND RETURNED TO ICAO TOGETHER WITH ANY COMMENTS YOU MAY HAVE ON THE PROPOSED AMENDMENTS

To: The Secretary General
 International Civil Aviation Organization
 999 University Street
 Montréal, Quebec
 Canada, H3C 5H7

(State) _____

Please make a checkmark (✓) against one option for each amendment. If you choose options “agreement with comments” or “disagreement with comments”, **please provide your comments on separate sheets.**

	<i>Agreement without comments</i>	<i>Agreement with comments*</i>	<i>Disagreement without comments</i>	<i>Disagreement with comments</i>	<i>No position</i>
Amendment to Annex 14, Volume I – <i>Aerodrome Design and Operations</i> (Attachment A refers)					
Amendment to Annex 15 – <i>Aeronautical Information Services</i> (Attachment B refers)					
Amendment to <i>Procedures for Air Navigation Services – Air Traffic Management</i> (PANS-ATM, Doc 4444) (Attachment C refers)					

*“Agreement with comments” indicates that your State or organization agrees with the intent and overall thrust of the amendment proposal; the comments themselves may include, as necessary, your reservations concerning certain parts of the proposal and/or offer an alternative proposal in this regard.

Signature: _____ Date: _____