



International Civil Aviation Organization

CAR/SAM REGIONAL PLANNING AND IMPLEMENTATION GROUP (GREPECAS)

**Sixth Meeting of the CNS Committee of the GREPECAS ATM/CNS Subgroup
(CNS/COMM/6)**

Santo Domingo, Dominican Republic, 30 June to 4 July 2008

CNS/COMM/6-WP/02

13/05/08

Agenda Item 1 Development of Communication Systems

1.1 Review of progress in the interconnection/integration of digital networks

FOLLOW UP TO THE MEVA II- REDDIG INTERCONNECTION ACTIVITIES

(Presented by the Secretariat)

SUMMARY	
This working paper presents a follow up to the MEVA II-REDDIG interconnection activities	
References: <ul style="list-style-type: none">• Report of the GREPECAS 14 Meeting (San José, Costa Rica 16-20 April 2007);• Report of the Fifth MEVA II - REDDIG Coordination Meeting (Mexico City, 3-5 October 2007); and• Report of the Sixth MEVA II - REDDIG Coordination Meeting (Lima, Peru, 7-8 May 2008).	
Strategic Objectives:	<i>This working paper is related to Strategic objective D.</i>

1. Introduction

1.1 The aeronautical fixed service communication requirements between the CAR/SAM/NAM Regions are specified in the regional plans contained in the Air Navigation Plan (Doc. 8733), Volume II – FASID, in Tables CNS 1A (AFTN Plan), CNS 1Ba (ATN router plan), CNS 1Bb (ATN ground-ground application plan) and CNS 1 C (ATS direct speech circuits plan).

1.2 These requirements must be met in order to cover the basic operational requirements and planning criteria specified in the Air Navigation Plan, Volume I, Basic ANP and are agreed upon by provider States and interested users. Each Contracting State is responsible for the supply of services and facilities in its territory, in compliance with Article 28 of the Chicago Convention, Doc. 7300.

1.3 Fixed aeronautical service communication requirements (AFTN, ATS speech circuits) between the SAM/CAR/NAM Regions are being fully met today through the use in some cases of national networks and circuits leased from telecommunication service providers.

1.4 The implementation in the CAR/SAM Regions of multiservice/multiprotocol networks with a massive information transmission capability, like REDDIG and MEVA II, has substantially

increased the availability of voice and data communications and has facilitated the introduction of new circuits to meet operational requirements, and has provided the capacity for future ATM/CNS systems.

1.5 Taking into account the characteristics of the VSAT REDDIG and MEVA II networks and their similarity and compatibility, the GREPECAS/13 meeting (Santiago, Chile, 14-18 November 2005) adopted Conclusion 13/70 – *Establishment of agreements to achieve MEVA II - REDDIG interconnection/interoperation.*

1.6 MEVA II - REDDIG interconnection/interoperation will make it possible to implement and optimise, at a lower cost, the existing requirements for aeronautical fixed service communications between the CAR/NAM and SAM Regions, to improve service availability and quality, and to facilitate the implementation of new circuits. The interconnection will mean replacing existing circuits implemented through national networks and those leased from different communication service providers. **Appendix A** to this working paper contains the existing ATS voice and data communication requirements between States, Territories and Organisations of the CAR/SAM and SAM/NAM Regions that will be met by this interconnection.

1.7 Six MEVA II - REDDIG coordination meetings and three meetings of the MEVA II - REDDIG interconnection task force were held to advance the studies for implementing the MEVA II - REDDIG interconnection.

1.8 The conclusion reached by those studies was that the MEVA II - REDDIG interconnection consists mainly of the implementation of the MEVA II MODEM at the Venezuelan and Colombian REDDIG nodes and of a REDDIG MODEM at the COCESNA MEVA II node. It was also agreed that the two networks would be integrated five years after their interconnection.

1.9 The following matters were defined for the MEVA II - REDDIG interconnection: the necessary technical and administrative requirements, a Memorandum of Understanding (MoU) between the members of MEVA II and REDDIG, the technical terms of reference, the responsibilities of the parties (REDDIG Administration and the MEVA II service provider) and an action plan.

2. Analysis

2.1 **Appendix B** to this working paper covers the MEVA II - REDDIG interconnection implementation activities carried since the Fifth MEVA II - REDDIG Coordination Meeting. Pending aspects for implementation of the MEVA II – REDDIG interconnection are described below, in light of the action plan updated and approved at the Sixth MEVA II – REDDIG Coordination Meeting (MR/6) held in Lima on 7-8 May 2008.

Focal point activities

2.2 **Appendix C** to this working paper lists the focal points and provides information on their street address, telephone number and e-mail address.

2.3 MR/06, through Conclusion MR06/01 – *Aspects to be considered for implementing the equipment for the MEVA II -REDDIG interconnection*, called for the designated focal points to coordinate the interconnection activities and, as their first activity, to determine the electric power, physical space, protection requirements, required cables, racks and other important data on the sites where the necessary equipment for the interconnection will be installed. **Appendices D and E** to this working paper list the equipment needed for the MEVA II - REDDIG interconnection implementation and contain a block diagram of the technical configuration of a MEVA II - REDDIG interconnection node.

2.4 In addition, the designated focal points will be responsible for coordinating the reception of the equipment acquired for the interconnection, the equipment installation work by the installer, the follow up on the installation work and participation in the operation acceptance tests of interconnected services, among other activities.

REDDIG Administration Activities

2.5 The REDDIG Administration, in order to comply with the foreseen MEVA II – REDDIG interconnection activities, is holding a public procurement tender for the equipment to be installed in the Caracas and Bogotá REDDIG nodes and the Tegucigalpa MEVA II node.

2.6 Furthermore, the REDDIG Administration and COCESNA are coordinating as necessary an agreement to establish the technical, administrative and financial responsibilities of the two parties.

2.7 The REDDIG Administration is likewise reviewing the MEVA II service supply contract, which specifies the activities the service provider will perform and the technical, administrative and financial responsibilities of the two parties (REDDIG Administration and the MEVA II service provider).

Activities of the MEVA II Service Provider

2.8 The MEVA II service provider will change the polarity of all antennas in the MEVA II network nodes from horizontal to vertical to permit the interconnection of the REDDIG and MEVA II networks. The changes in polarity will be made once the REDDIG Administration reviews and signs the contract prepared by the MEVA II service provider.

Memorandum of Understanding (MoU) for the MEVA II- REDDIG interconnection

2.9 The MoU for the MEVA II - REDDIG interconnection is established for the purpose of facilitating coordinated planning for the development of the MEVA II and REDDIG networks and their interconnection.

2.10 The MoU stipulates the necessary technical, operational and administrative aspects for the interconnection of the MEVA II and REDDIG VSAT digital networks, in order to meet aeronautical telecommunication requirements between the CAR/SAM Regions.

2.11 All of the States/Territories and Organisations members of the MEVA II and REDDIG networks have expressed their willingness to accept the MoU. Many of the members of the two networks have already signed that MoU and the rest are expected to do so shortly.

Satellite Contingency Plan

2.12 During the Sixth MEVA II - REDDIG Coordination Meeting (MR/6), the REDDIG Administration and the MEVA II service provider presented a satellite contingency plan to be applied in the event of satellite transponder failure or of a total satellite failure.

2.13 It was reported at that same meeting that INTELSAT plans to launch a new INTELSAT 14 (IS-14) satellite in the second quarter of 2009 to replace its current IS-1R (formerly known as PAS-1R) satellite. The IS-14 satellite will occupy the same 45W orbit position as the IS-1R.

2.14 The REDDIG Administration and the MEVA II service provider have expressed their intention, in this regard, to migrate to the new satellite on the cited date in order to keep the two networks interconnected. They will, therefore, coordinate with INTELSAT as needed to migrate to the new IS 14 satellite.

MEVA II- REDDIG Interconnection Date

2.15 According to the schedule of activities specified in the action plan reviewed and approved at the Sixth MEVA II – REDDIG (MR/6) Coordination Meeting, which is presented as **Appendix F** to this working paper, the interconnection and start-up of services between the two networks are expected to take place during the first quarter of 2009.

3. Suggested action

3.1 The Meeting is invited to:

- a) take note of the information supplied in this paper and its appendices;
- b) analyse the pending activities described in section 2 of this working paper and Appendix F, which describes the MEVA II - REDDIG interconnection action plan by the MR/06 Meeting;
- c) suggest any other aspect relating to the MEVA II – REDDIG interconnection it deems necessary.

APPENDIX A

ATS SPEECH AND DATA REQUIREMENTS AMONG CAR/SAM STATES, TERRITORIES AND ORGANIZATIONS

Summary of CAR/SAM interoperability requirements																		
No.	State/Station	ARUBA, Aruba	COLOMBIA Barranquilla	Bogota	Cali	Medellín	San Andrés	ECUADOR, Guayaquil	JAMAICA, Kingston	NETHERLANDS A. Curacao	PANAMÁ, Panamá	PUERTO RICO, San Juan	VENEZUELA Caracas	Josefa Camejo	COCESNA, Tegucigalpa	Total per State		
1	2	3	4	5	6	7	8	9	10	11	12	13	14	15	16	17	18	19
1	ARUBA, Aruba															V		1 Voice
2	COLOMBIA																	8 Voice + 1 Data
2.1	Barranquilla									V	V							
2.2	Bogotá											D,V					V	
2.3	Cali											V						
2.4	Medellín											V						
2.5	San Andrés											V						
3	ECUADOR, Guayaquil																V	1 Voice
4	JAMAICA, Kingston			V														1 Voice
5	NETHERLANDS A. Curacao			V											D,V			2 Voice + 1 Data
6	PANAMÁ, Panama			V	D,V	V	V	V										5 Voice + 1 Data
7	PUERTO RICO, San Juan															D,V		1 Voice + 1 Data
8	VENEZUELA																	3 Voice + 2 Data
8.1	Caracas										D,V		D,V					
8.2	Josefa Camejo	V																
9	COCESNA, Tegucigalpa				V				V									2 Voice
	Total per Station	1 Voice	3 Voice	2 Voice + 1 Data	1 Voice	1 Voice	1 Voice	1 Voice	1 Voice	2 Voice + 1 Data	5 Voice + 1 Data	1 Voice + 1 Data	2 Voice + 2 Data	1 Voice	2 Voice			

**ATS SPEECH AND DATA REQUIREMENTS AMONG NAM/SAM STATES, TERRITORIES
AND ORGANIZATIONS**

Summary of NAM/SAM interoperability requirements	
Communications service	Type
2	3
BRASIL , Brasilia AFTN trunk circuit – UNITED STATES	Data
PERU , Lima AFTN trunk circuit – UNITED STATES	Data
VENEZUELA , Caracas AFTN trunk circuit – UNITED STATES	Data
ATN routers No. 1 interconnection (Plan under review)	Data
ATN routers No. 2 interconnection (Plan under review)	Data

***Note:** In addition to the requirements indicated in the Table, ATN routers interconnections, new services for the exchange of radar data and other communications will have to be added, all of which are in the process of review and definition.*

APPENDIX B

FOLLOW UP TO ACTIVITIES CARRIED OUT FOR THE IMPLEMENTATION OF THE MEVA II / REDDIG NETWORKS INTERCONNECTION

Following is a description of the main activities carried out of the implementation of MEVA II / REDDIG interconnection on the basis of the action plan elaborated at the fourth MEVA II / REDDIG Coordination Meeting (MR/4), and updated at the MR/5 and MR/6 meetings. The activities described refer to the analysis made to the RFP response, the nomination of focal points, the application of the revised MoU, the costs review and acceptance for MEVA II / REDDIG interconnection, and the review and signature of the AGS contract by the REDDIG Administration.

1. Response to the RFP

1.1 The MEVA II Service Supplier presented during the MR/5 his response to the RFP (proposal for technical and economical requirements for the MEVA II / REDDIG interconnection). The documentation was presented in two volumes, Volume I with information referring to the technical proposal for MEVA II/REDDIG interconnection implementation, and Volume II that contains the economical proposal to implement the interconnection.

1.2 The MR/5 Meeting when analyzing the response to the RFP by the MEVA II Service Supplier, considered that this presented in a detail way all the aspects required to implement MEVA II/REDDIG interconnection.

1.3 However, MR/5 Meeting considered that the response to the RFP needed a revision regarding some technical and economical aspects, formulating in this respect Conclusion MR 5/1 (*Review of the Response from the MEVA II Service Provider to the MEVA II / REDDIG RFP*) in which MEVA II supplier was being requested to forward to the ICAO Mexico Regional Office the revision to the RFP before 19 October 2007.

1.4 RFP response revision was sent to the MEVA II Service Provider on November 2007. In the revised response, it can be observed, among other aspects, that same does not indicate whether Venezuela node requires an amplifier with more power.

1.5 In MR/6 meeting, the MEVA II Service Provider presented a list with equipment necessary for MEVA II / REDDIG interconnection, and an updated economical proposal. **Appendices D and E** to this working paper present, respectively, the list of equipment necessary for the implementation of the MEVA II / REDDIG interconnection, and a typical block interconnection diagramme.

1.6 MR/5 meeting also reviewed the REDDIG Administration response to the RFP, comments to this response were formulated during this Meeting.

2. Focal points nomination

2.1 MR/6 meeting updated the list of focal points, presented in **Appendix C** to the working paper. MR/6 meeting considered that, as a first activity, the focal points must provide to the respective ICAO Regional Offices, and before 6 June 2008, information related with the following aspects, necessary for the installation of the equipment: power supply, physical space for the new elements, required electrical protections. To this end, it formulated Conclusion MR 06/01 - *Aspect to be considered for the implementation of equipment for the MEVA II REDDIG interconnection*.

3. **Application of the revised MoU**

3.1 The MR/5 recalled that the GREPECAS/14 Meeting, held in San José, Costa Rica from 16 to 20 April 2007, reviewed the development and integration/interconnection status of both regional networks, and drafted Conclusion 14/52 – *Review for the Adoption of the Memorandum of Understanding and Implementation of the Action Plan for the MEVA II / REDDIG Interconnection*, through which, among other aspects, urged MEVA II / REDDIG member Administrations to “study and review the feasibility to adopt the Memorandum of Understanding (MoU).”

3.2 Taking into account the proposals for amendment to the MoU received by the Regional Offices, the MR/5 adopted the revised MoU. The changes made to the MoU have been made only to specify the solution for implementation of the MEVA II / REDDIG interconnection, as well as any aspects relevant to the form of doing so. The integration agreements are contemplated to be carried out by the end of the interconnection. It is considered that the essential technical-administrative content of the initial MoU version, which represents the main purpose of the document, has remained without major changes.

3.3 The MR/5 agreed that the revised version of the MoU, which was adopted by this Meeting, should be re-circulated. Members are urged to sign the revised version of the MoU, formulating Conclusion MR 5/3 - *Adoption of the revised MoU for the MEVA II / REDDIG interconnection*. Since the MoU revised version remission, no ICAO Office has received objections nor comment to the referred document; presently States/Territories/Organization members of the MEVA II / REDDIG that have signed the MoU are Argentina , Brazil, Chile, Cuba, COCESNA, Guyana, Peru, United States and Uruguay.

4. **Review of and agreement with MEVA II/REDDIG interconnection costs**

4.1 The States/Territories/International Organization member of REDDIG and MEVA II networks did not send comments regarding MEVA II Service Supplier’s and REDDIG Administration proposed prices, therefore, MR/6 meeting considered that these costs could be considered as accepted.

5. **AGS Contract revision and signature by the REDDIG Administration**

5.1 The MR/5 formulated Conclusion MR 5/5 - *Request for a Contract Proposal Between the MEVA II Service Provider and the REDDIG Administration* in order that MEVA II Supplier provide a contract form with the purpose that the REDDIG Administration be able to review it for its signature to continue with the interconnection implementation process.

5.2 MEVA II service provider sent the contract form to ICAO at the beginning of November 2007. This was forwarded to ICAO Montreal Technical Cooperation Bureau at the beginning of December 2007. The revision of the contract by the Technical Cooperation Bureau has been considerably delayed.

5.3 To this effect, during MR/6 meeting information was received that TCB will proceed with a public bidding process for the purchasing of the equipment necessary for the interconnection, and that same would take approximately two months.

5.4 For the provision of the service, TCB considered it would resort to the MEVA II Service Provider, in view that that the characteristics of the MEVA II / REDDIG interconnection only can be carried out by the MEVA II Service Provider.

5.5 To this effect, the MEVA II Service Provider was formally requested to modify the contract format so it only include the services, eliminating the equipment necessary for the interconnection, and that it review its economical proposal taking into account these changes.

5.6 As a consequence of the delays in the signature of the contract with AGS, the dates of the revised action plan work programme were updated, which is attached as **Appendix F** to this working paper.

5.7 MR/6 meeting, in order to comply with the implementation dates for the activities specified in the revised Action Plan, urged ICAO, through TCB, to speed the process necessary for the review and signature of the contract with the MEVA II Service Provider, as well as the international public bid for the purchase of the equipment necessary for MEVA II / REDDIG interconnection, formulating Conclusion MR 6/3 - *Speed up MEVA II provider contract revision and signature and as well as the public bidding for the MEVA II REDDIG interconnection necessary equipment purchase.*

APENDICE C / APPENDIX C

**PUNTOS FOCALES PARA COORDINAR LA IMPLEMENTACIÓN DEL PLAN DE ACCIÓN
INTERCONEXIÓN MEVA II/REDDIG**

**FOCAL POINT FOR COORDINATING THE IMPLEMENTATION OF THE ACTION PLAN
MEVA II/REDDIG INTERCONNECTION**

ESTADO ORG./ STATE ORG.	NOMBRE-TITULO/ NAME- TITLE	DATOS DE CONTACTO/ CONTACT INFORMATION
BRASIL	<p>Athayde Licerio Viera Frauche Coordinador de la REDDIG</p> <p>Jorge Mauricio Motta Coordinador Técnico REDDIG</p>	<p>DECEA Av. General Justo 160 Castelo, Rio de Janeiro, Brasil Tlf 55 21 21016584 Fax: 55 21 21016219 Email dcte5@decea.gov.br</p> <p>CINDACTA IV Av. Do Turismo sin Taruma Manaus – AM, Brasil Tlf: 55 92 3652 5536 Fax: 55 92 3652 5501 Email: mauriciojmm@cindacta4.decea.gov.br</p>
COLOMBIA	<p>Sr Edgar Clavijo</p> <p>Grupo de proyectos Internacionales</p>	<p>Unidad Administrativa Especial de Aeronáutica Civil - UAEAC Dirección Telecomunicaciones Aeropuerto Internacional El Dorado Tel.: (571) 266-3672 Fax: (571) 222-3486</p>
ECUADOR	<p>Sr. Raúl Avellán Oña Asuntos técnicos:/Technical matter</p> <p>Sr. Víctor Acosta Caizapanta Asuntos administrativos /Administrative matter</p>	<p>Aeropuerto José Joaquín Olmedo Guayaquil, Ecuador Tel.: (59342) 692829 Cel.: (59384) 362441 REDDIG: 2308 / 2309 Email: ravellan1@yahoo.com</p> <p>Dirección General Aviación Civil Quito, Ecuador Tel.: (5932) 2567822 Cel.: (5939) 9664148 Mail: victor_acosta@dgac.gov.ec</p>
PERÚ	<p>Sr José Luis Paredes Dávila</p>	<p>CORPAC S.A. Tel.: (511) 708 1196 Cel.: (511) 99582 5997 Mail: jlparedes@corpac.gob.pe</p>

ESTADO ORG./ STATE ORG.	NOMBRE-TITULO/ NAME- TITLE	DATOS DE CONTACTO/ CONTACT INFORMATION
VENEZUELA	<p>Luis E. Escobar Jefe Telecomunicaciones Aeropuerto Maiquetía</p> <p>Wilton R. Linarez Coordinador de Telecomunicaciones</p>	<p>Aeropuerto Simon Bolivar, Edif.. ATC, Piso 2 Maiquetía, Venezuela Tel: 58 212 355 2143 Fax: 58 212 355 1412 Email: escoguil5@cantv.net l.escobar@inac.gov.ve</p> <p>Instituto Nacional de Aeronáutica Civil (INAC) Altamira Sur, Torre Británica, Piso 2 Caracas, Venezuela Tel: + 58 212 277 4403 Fax: + 58 212 277 4403 E-mail w.linarez@inac.gov.ve</p>
COCESNA	<p>Sr. Roger Perez Gerente Estación Honduras /Honduras General Manager</p>	<p>COCESNA Tel. + 504 234 3360 ext. 1461 Fax + 504 234 3682 E-mail rperez@cocesna.org</p>

APENDICE D / APPENDIX D

**LISTA DE EQUIPAMIENTO PARA LA INTERCONEXION /
LIST OF EQUIPMENT REQUIRED FOR THE INTERCONNECTION**

LOCALIDAD / LOCATION	EQUIPO ADICIONAL/PARTES REQUERIDAS / ADDITIONAL EQUIPMENT/PARTS NEEDED	CANTIDAD / QUANTITY
COCESNA	Linkway 2100 with frame-relay card and V.35 cable	1
	Memotec DAV Card	1
	Memotec FXS SLIM LID	2
	Memotec V.35H Card	1
	2-port L-band Splitter	1
	2-port L-band Combiner	1
Curacao	Memotec DAV Card	1
	Memotec FXS SLIM LID	1
	Memotec V.24 Card	1
Caracas	Linkway 2100 with frame-relay card and V.35 cable	1
	Memotec DAV Card (2 for MUX A, 2 for MUX B)	4
	Memotec FXS SLIM LID (3 for MUX A, 3 for MUX B)	6
	2-port L-band Splitter	3
	2-port L-band Combiner	3
	Paradise 75W BUC	2
Bogota	Linkway 2100 with frame-relay card and V.35 cable	1
	Memotec V.35H Card	1
	Memotec E1 DIM (1) for MPS A, (1) for MPS B to be installed in slot 2	2
	2-port L-band Splitter	3
	2-port L-band Combiner	3
Jamaica	Memotec DAV Card	1
	Memotec FXS SLIM LID	1
Miami	Memotec 960e Chassis	1
	Memotec 960e CPU	1
	Memotec 960e Power Supply	1
	Universal I/O	1
Panama	Memotec DAV Card	1
	Memotec FXS SLIM LID	2
	Memotec Multi I/O card	1
San Juan	Memotec DAV Card	1
	Memotec FXS SLIM LID	1
	Memotec Multi I/O card	1
Ecuador	E-1 Daughter Card for Memotec A and Memotec B	2

UNCLASSIFIED/COMPANY CONFIDENTIAL This document contains information proprietary to AMERICOM GOVERNMENT SERVICES, INC.

REVISION HISTORY				
ZONE	REV	DESCRIPTION	DATE	Revised By
1	B	Added Combiners & Dividers	09/29/07	EFM
1	C	Removed One MEVA II LinkWay	10/15/07	EFM

Block Diagram MEVA II Node at REDDIG Site

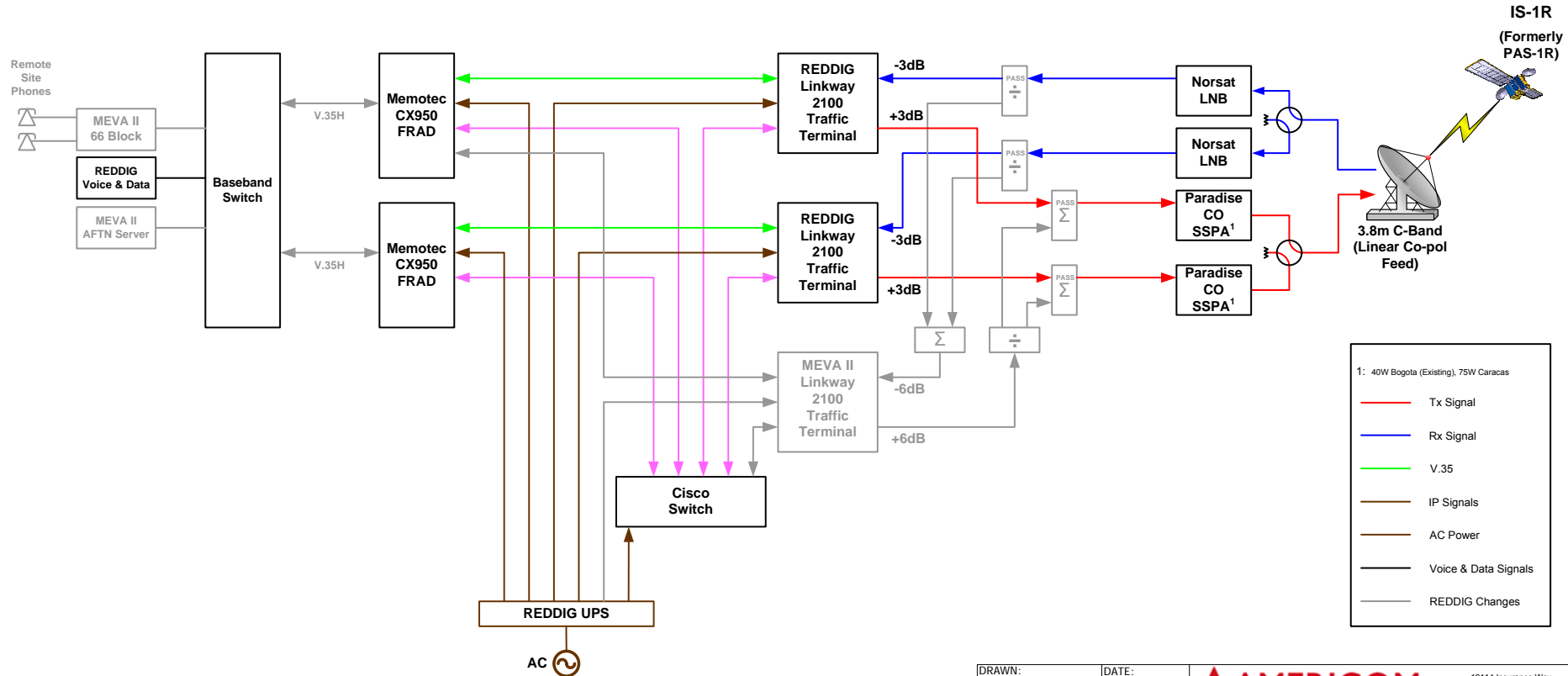

1: 40W Bogota (Existing), 75W Caracas

- Tx Signal
- Rx Signal
- V.35
- IP Signals
- AC Power
- Voice & Data Signals
- REDDIG Changes

DRAWN: DS	DATE: 09/29/2007	AMERICOM GOVERNMENT SERVICES	12114 Insurance Way Hagerstown, MD 21740 (301) 797-5093 www.americom-gs.com		
CHECKED:	DATE:		Block Diagram Remote MEVA II/REDDIG		
MFG:	DATE:				
TITLE		SIZE: B	CAGE CODE: 1WJY6	DWG NO:	REV: C
SCALE:		SHEET 1 OF 1			

PLAN DE ACCIÓN ACTUALIZADO PARA LA IMPLANTACIÓN DE LAS INTERCONEXIONES MEVA II Y REDDIG
UPDATED ACTION PLAN FOR THE IMPLEMENTATION OF MEVA II AND REDDIG INTER-CONNECTION

Date/Fecha: April/Abril 2008

Item No.	Action / Acción	Responsible / Responsable	Completion Date / Fecha de Finalización	Status- Encountered Difficulties / Estado-Dificultades encontradas
1	2	3	4	5
1	RFP Completion/Finalización del RFP	COCESNA	30-Apr-07	Completed / Finalizado
2	Required connections: / Conexiones requeridas: Aruba COCESNA Ecuador Colombia Peru Venezuela Brazil / Brasil Panama United States / Estados Unidos Jamaica Curacao / Curazao	MEVA II Service Provider and REDDIG Administration / Proveedor Servicio MEVA II y Administración REDDIG	30-Apr-07 / 30-Abr-07	Completed / Finalizado
3	Identification of Current Equipment / Identificación de Equipo Actual	MEVA II Service Provider and REDDIG Administration / Proveedor Servicio MEVA II y Administración REDDIG	28 Sep-07	Completed / Finalizado
4	Completion of SLA / Finalización de SLA	MEVA II Service Provider and REDDIG Administrator / Proveedor Servicio MEVA II y Administración REDDIG	30 Nov07	Valid/Valido Is part of the Service Contract/Es parte del Contrato de Servicio
5	Review of RFP / Revisión de RFP	MEVA II and REDDIG Members / Miembros MEVA II y REDDIG	29 June -07/ 29 Junio 07	The RFP was reviewed and approved by all MEVA II / REDDIG Member Administrations. / El RFP fue revisado y aprobado por todas las Administraciones miembros de las redes MEVA II y REDDIG.

Item No.	Action / Acción		Responsible / Responsable	Completion Date / Fecha de Finalización	Status- Encountered Difficulties / Estado-Dificultades encontradas
1	2		3	4	5
6	Proposals response / Respuesta de propuestas		MEVA II Service Provider and REDDIG Administration / Proveedor Servicio MEVA II y Administración REDDIG	26 Sep.-07	The response for the RFP from the MEVA II Service Provider and REDDIG Administration was presented at the MR/5 Meeting/ Las respuestas al RFP por parte del Proveedor de Servicio MEVA II y la Administración de la REDDIG se presentó en la Reunión MR/5.
7	Proposals review / Revisión de propuestas		Coordination meeting / Reunión de coordinación	5 Oct.-07	The proposal was reviewed in the MR/5 Meeting. / La propuesta se revisó en la Reunión MR/5.
8	Focal Point nomination / Nombreamiento Punto Focal	Send a letter to MEVA II / REDDIG Member Administrations / Envío carta a las Administraciones miembros de las redes MEVA II y REDDIG.	ICAO Regional Offices / Oficinas Regionales OACI	15 Oct. 07	The ICAO Regional Offices sent to the States/Organization involved in the MEVAII REDDIG interconnection a letter in order to nominate focal points. Las oficinas regionales de la OACI enviaron una carta invitando los Estados/Organización involucrados en la interconexión la nominación de puntos focales.
		Focal point designation/ Designación punto focal	MEVA II and REDDIG Members involved / Miembros de MEVA II y REDDIG involucrados	30-Oct-07	All the States/Organization members of MEVA II and REDDIG network involved in the interconnection nominated focal points. Todos los Estados/Organización miembros de la REDDIG y MEVA II involucrados en la interconexión nominaron puntos focales
9	Application of MoU reviewed / Aplicación del MoU revisado		MEVA II / REDDIG Member Administrations / Administraciones miembros de las redes MEVA II y REDDIG	30-Oct-07	The ICAO Regional Offices sent to the States/Organization of MEVA II and REDDIG network in order to sign the MoU reviewed.

Item No.	Action / Acción	Responsible / Responsable	Completion Date / Fecha de Finalización	Status- Encountered Difficulties / Estado-Dificultades encontradas
1	2	3	4	5
10	Review and acceptance of equipment costs for the MEVA II / REDDIG interconnection by the REDDIG Member Administrations / Revisión y aceptación por parte de las Administraciones Miembros de la REDDIG sobre costo de equipamiento para la interconexión MEVA II / REDDIG	All the REDDIG Member States / Todos Estados miembros de REDDIG	30 Oct-07	No comments were received No se recibieron comentarios al respecto
11	Review and acceptance of equipment costs for the MEVA II / REDDIG interconnection by the MEVA II Member Administrations involved / Revisión y aceptación por parte de las Administraciones Miembros de la MEVA II involucradas sobre costo de equipamiento para la interconexión MEVA II / REDDIG	Aruba, Curaçao, Jamaica, Panama, USA (Miami and Puerto Rico) and COCESNA / Aruba, Curaçao, Jamaica Panamá, USA (Miami y Puerto Rico) y COCESNA	30 Oct -07	No comments were received No se recibieron comentarios al respecto
12	Review and acceptance of proposed recurrent costs for the MEVA II / REDDIG interconnection/ Revisión y aprobación costos recurrentes propuestos para la interconexión MEVA II REDDIG	MEVA II/ REDDIG Member Administrations involved / Administraciones Miembros de la MEVA II y REDDIG involucradas	30 Oct- 07	No comments were received No se recibieron comentarios al respecto
13	Revised MoU Signature / Firma del MoU Revisado	MEVA II and REDDIG Members / Miembros MEVA II y REDDIG	30 Nov 07	The following States sent the MoU reviewed signed/Los siguientes Estados enviaron el MoU revisado firmado: Argentina, Brasil, Chile, Cuba, COCESNA, Estados Unidos, Guyana, Peru y/and Uruguay

Item No.	Action / Acción	Responsible / Responsable	Completion Date / Fecha de Finalización	Status- Encountered Difficulties / Estado-Dificultades encontradas
1	2	3	4	5
14	Review, approval and signing of contracts or contract amendments to carry out the MEVA II / REDDIG interconnection presented by the MEVA II Service Provider / Revisión, aprobación y firma de los contratos o enmienda de los mismos para llevar a cabo la interconexión MEVA II/REDDIG presentada a través del Proveedor de Servicio de la MEVA II	MEVA II Member Administrations involved and REDDIG Administration / Administraciones Miembros de la MEVA II involucradas y Administración REDDIG	30 Nov 07/ June 2008/ Junio 2008	<p>The REDDIG members assigned REDDIG Administration the revision and signature of AGS contract. The ICAO Technical Cooperation after reviewed the AGS contract considered the necessity to separate the no recurrent and recurrent costs. The decision took long time from December 2007 to April 2008. For the acquisition of the equipment a bid is necessary and so ICAO Technical Cooperation will proceed with this process. For the services cost AGS is to modify the contract in order to include only the service costs.</p> <p>Los miembros de la REDDIG asignaron a la Administración de la REDDIG la revisión y firma del contrato. La Cooperación Técnica de la OACI después de revisar el contrato de AGS consideró la necesidad de separar los costos recurrentes de los no recurrentes. La decisión fue tomada después de un largo periodo de diciembre de 2007 a abril de 2008. Para la adquisición del equipo se procederá a un proceso de licitación pública y por lo cual Cooperación Técnica de la OACI procederá según este proceso. Para los costos de los servicios se consideró que AGS modificara el contrato de forma tal que incluyera solamente los costos de los servicios.</p>

Item No.	Action / Acción	Responsible / Responsable	Completion Date / Fecha de Finalización	Status- Encountered Difficulties / Estado-Dificultades encontradas
1	2	3	4	5
15	To ensure that all MEVA II and REDDIG nodes work with IS-IR Satellite, using Band C transponder with US/Latin America hemispheric beam and Co-Linear Vertical polarization / Asegurar que todos los nodos de la MEVA II y REDDIG operen en el satélite IS-1R, empleando transpondedores de banda C con haz hemisférico US/Latin America y polarización co-lineal vertical.	MEVA II Service Provider and REDDIG Administration/ Proveedor Servicio MEVA II/Administración REDDIG	30 Nov 07 June 08/ Junio 08	No change of polarity was executed. AGS is will proceed upon the signature of the contract for this interconnection. No se ha efectuado todavía el cambio de polaridad. AGS procedera cuando se firme el contrato para esta interconexión.
16	Equipment and spare parts acquisition for MEVA II/REDDIG interconnection/ Adquisición de equipamiento y repuestos para la interconexión MEVA II / REDDIG.	REDDIG Administration and MEVA II involved Member Administrations / Administración de la REDDIG y Administraciones Miembros de la MEVA II involucradas	14 Dec 07/14 Dic 07 End of July 08/Fin de julio 08	The ICAO Technical Cooperation informed that the bid process for the acquisition of equipments through a bid process will take a duration of approximately two months. La Cooperación Técnica de la OACI informó que el proceso de licitación para la adquisición de los equipos durara dos meses aproximadamente.
17	Site survey for Bogota, Caracas and COCESNA, / Inspección sitio para Bogota, Caracas and COCESNA,	MEVA II Service Provider and REDDIG Administration / Proveedor MEVA II y Administración REDDIG	15 Jan 08/15 Ene 08 End of July 08/Fin de Julio 08	Site survey is considered as part of the services to be provided. El estudio de sitio se considera parte de los servicios a ser provistos.
18	Site preparation for equipment installation for MEVA II / REDDIG interconnection / Preparación de los sitios para albergar equipamiento para la interconexión MEVA II / REDDIG	Colombia, Venezuela and/y COCESNA	30 Jan 08/30 Ene 08 Aug08/Ago08	
19	Delivery of purchased equipment at the required sites. / Entrega de equipamiento adquirido en los sitios requeridos	MEVA II Service Provider and REDDIG Administration / Proveedor de Servicio MEVA II y Administración REDDIG	15 Feb 08 Sep08	

Item No.	Action / Acción	Responsible / Responsable	Completion Date / Fecha de Finalización	Status- Encountered Difficulties / Estado-Dificultades encontradas
1	2	3	4	5
20	Equipment installation / Instalación equipamiento	MEVA II Service Provider and REDDIG Administration / Proveedor de Servicio MEVA II y Administración REDDIG	14 Mar-08 Oct08	
21	Satellite line-up, configuration of site equipment and NCC for the interconnection/ Line-up satelital, configuración equipamiento en sitio y NCC para interconexión	MEVA II Service Provider and REDDIG Administration / Proveedor de Servicio MEVA II y Administración REDDIG	21 Mar-08 Oct08	
22	End-to-end trials for voice and data circuits / Pruebas de extremos a extremos para los circuitos de voz y datos	MEVA II Service Provider and REDDIG Administration / Proveedor de Servicio MEVA II y Administración REDDIG	27 Mar-08 Nov 08	
23	System Performance Evaluation / Evaluación de la performance del sistema	MEVA II Service Provider and REDDIG Administration / Proveedor de Servicio MEVA II y Administración REDDIG	25 Apr-08/25 Abr-08 Dec08/Dic08	
24	Service acceptance / Aceptación de los servicios /	MEVA II / REDDIG Member Administrations / Administraciones miembros de las redes MEVA II y REDDIG	30 Apr-08/30 Abr-08 Jan09/Ene09	
25	MEVA II / REDDIG Interconnection Implementation / Implantación de la interconexión MEVA II / REDDIG	MEVA II / REDDIG Member Administrations, MEVA II Service Provider and REDDIG Administrator / Administraciones miembros de las redes MEVA II y REDDIG, Proveedor Servicio MEVA II y Administración REDDIG	May-08/ Mayo-08 Feb09	

Legend / Leyenda:

MoU: Memorandum of Understanding / Memorando de Entendimiento

RFP: Request for Technical and Economic Proposal / Solicitud de Propuestas Técnicas y Económicas

SLA: Service Level Agreement / Acuerdo de Nivel de Servicio