

# Automatic Dependent Surveillance –Broadcast (ADS-B) Awareness Seminar.

Presented by:  
Rickford Samaroo.



# AUTOMATIC DEPENDENT SURVEILLANCE- BROADCAST ADS-B

- Aircraft determines its position using navigation equipment (GPS)
- Aircraft broadcasts position, identity, altitude and velocity information (“ADS-B OUT”)
- Ground stations receive the broadcasts and relay the information to air traffic control
- Other aircraft receive broadcasts & display to pilot (“ADS-B IN”)



# OUTLINE

- **ICAO Aeronautical Surveillance – Strategy:**

- The need, purpose and scope for Aeronautical Surveillance.
- Surveillance categories.
- Basic principle of operation.
- Application of ATS Surveillance

- **ADS-B**

- Theory of operation
- System description
- Functional description and application in ATM.
- Limitations
- Remote control and monitoring system (RCMS)

- **ATM**

- Flight planning
- Separation standards
- Phraseology.

- **AIRBORNE EQUIPMENT**

- GNSS – IFR - RECEIVER WITH WAAS
- Transponder 1090 ES

# OBJECTIVES -1

- Upon completion of the presentation you will be able to;
- Explain what is Aeronautical Surveillance and state its purpose.
- List the categories of Surveillance systems
- Describe the principle of operation, coverage procedures and limitations.

# OBJECTIVES -2

- ADS-B;
- Explain the Theory of operation.
- Describe the system architecture.
- Describe normal ADS B out operation.
- Explain the benefits and limitations of ADS-B

# OBJECTIVES -3

- ATM:
- Describe the approval and flight planning process.
- Identify the ICAO separation standards
- Explain the use of ADS-B specific phraseologies.



# ICAO Aeronautical Surveillance

- **Overview.**
- Air traffic is growing at a significant rate and at the same time, there are increasing demands for more operating flexibility to improve aircraft efficiency and to reduce the impact of air travel on the environment.
- Aeronautical surveillance systems are major elements of modern air navigation infrastructure and are required to safely manage increasing levels and complexity of air traffic.

# ICAO Aeronautical Surveillance

- **Need:**
- Surveillance plays an important role in ATM. The ability to accurately determine, track and update the position of aircraft has a direct influence on the **minimum distances by which aircraft must be separated** (i.e. separation standards), and therefore on how efficiently a given airspace may be utilized.

# ICAO Aeronautical Surveillance

- **Need:**
- Accurate surveillance can be used as the basis for automated alerting systems.
- The ability to accurately track aircraft enables Air Traffic Control (ATC) to be alerted when an aircraft is detected to deviate from its assigned **altitude or route** or when the future positions of two or more aircraft are predicted to fall below minimum acceptable separation standards.
- Alerts may also be provided when the aircraft strays below the **minimum safe altitude** or enters a restricted area.

# ICAO Aeronautical Surveillance

- **Purpose and Scope:**
- An aeronautical surveillance system provides the aircraft position and other related information to ATM and/or airborne users.
- In most cases, an aeronautical surveillance system provides **its user with knowledge of “who” is “where” and “when.”**
- Other information provided may include horizontal and vertical speed data, identifying characteristics or intent.
- The required data and its technical performance parameters are specific to the application that is being used.
- As a minimum, the aeronautical surveillance system provides **position information on aircraft or vehicles at a known time.**

# ICAO Surveillance strategy.

- • Primary Radar (SMR/ASDE);
- • Secondary Surveillance Radar (SSR);
- • Automatic Dependent Surveillance-Broadcast (ADS-B);
- • Automatic Dependent Surveillance-Contract (ADS-C); and
- • Multilateration.

# ICAO Aeronautical Surveillance

Surveillance categories.



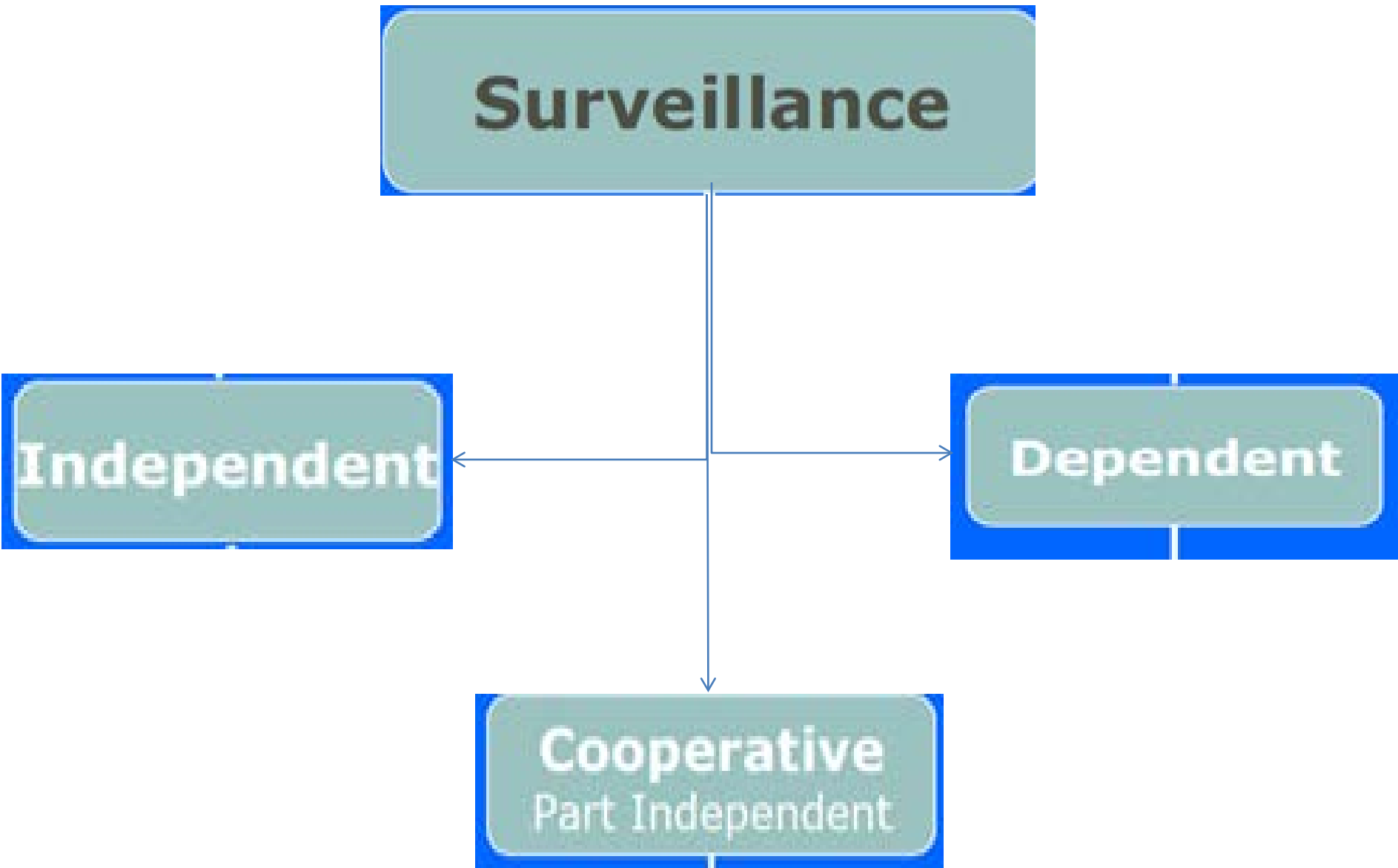

Surveillance categories.

# Examples of Surveillance categories.

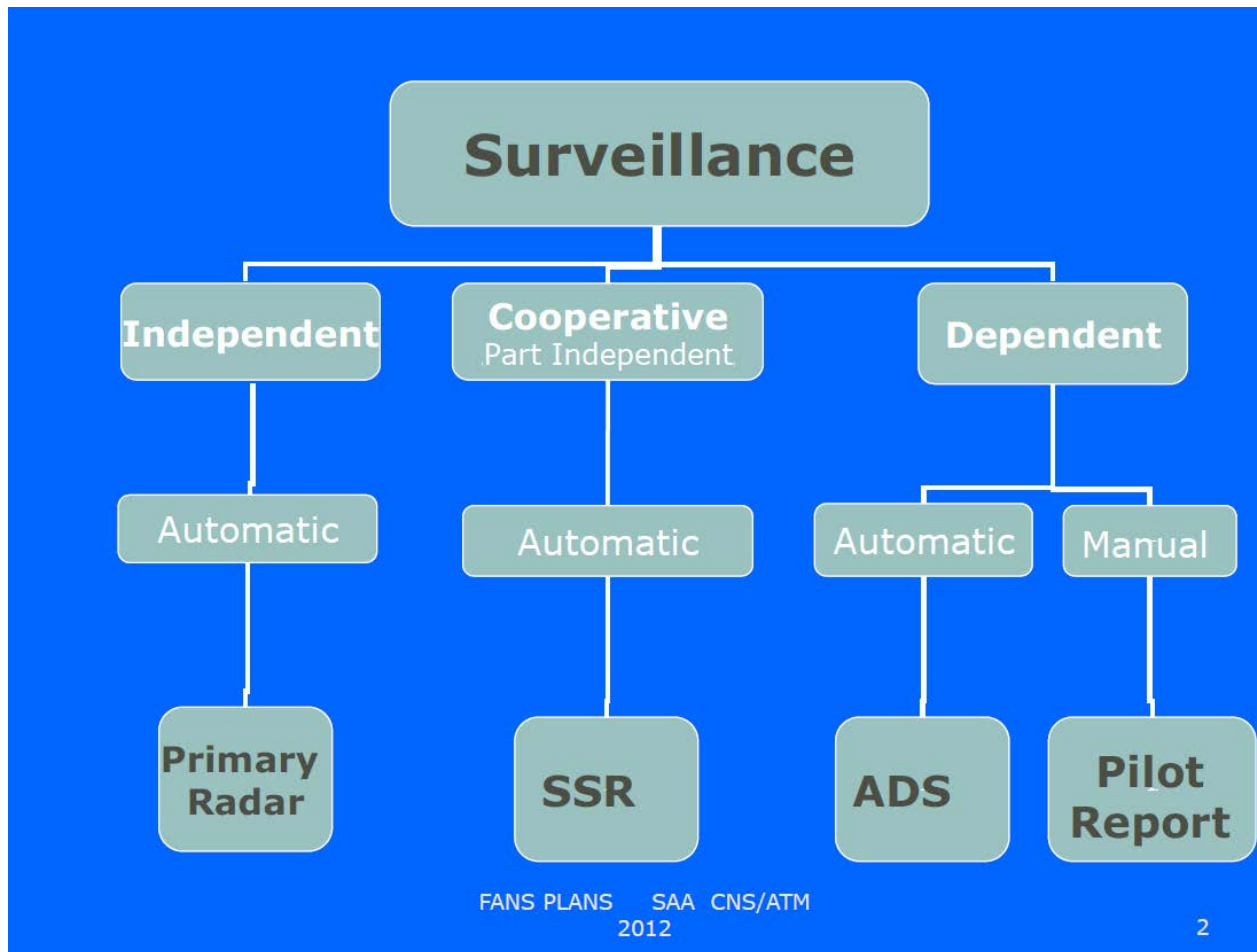

Conventional surveillance technologies rely on data acquisition from the sensors:

- a) Primary Surveillance Radars (PSR)
- b) Secondary Surveillance Radars (SSR)

Complementary surveillance technology: Automatic Dependent Surveillance – Broadcast (ADS-B)

Type	Aircraft Position Acquisition	Position Determination Technology
PSR	Independent: aircraft position is determined by the radar.	Not cooperative: does not depend on aircraft equipment
SSR	Independent: aircraft position is determined by the radar.	Cooperative: requires aircraft to have a ATCRBS/Mode S transponder in operation.
ADS-B	Dependent: ADS-B station derives an aircraft position from the signals broadcasted by the aircraft and carrying its position encoded in them.	Cooperative: requires aircraft to have ADS-B transceiver or Mode S Extended Squitter in operation.

# MULTILATERATION

Type	Aircraft Position Acquisition	Position Determination Technology
MLAT	Independent: aircraft position is determined by the receiver stations.	Cooperative: requires aircraft to have a ATCRBS/Mode A/C/S transponder in operation.

# SURVEILLANCE TECHNOLOGIES

OVERVIEW

OF BASIC OPERATING PRINCIPLE.

# Surveillance Technologies Overview

## Primary Surveillance Radar



- Tx signal is radiated by the antenna, reflected back by aircraft body and detected by the radar receiver.
- Tx signal should be of high peak power in order to “see” targets far enough from the radar site.
- Comprehensive signal processing is required in the radar receiver to detect weak reflections.

For Radar Cross Section  $RCS=2$  sq.m and Probability of Detection  $P_d=0.8-0.95$ :

- L-band (1.25-1.35 GHz) radar range: 200-220 nmi @Tx peak power  $P=45$  KW;
- S-band (2.7-2.9 GHz) radar range: 60 – 80 nmi @Tx peak power  $P=25$  KW.
- L-band antenna Gain= 33 dBi @W x H=13.6m x 8.7 m
- S-band antenna Gain= 33 dBi @W x H=5m x 2.9 m

# Surveillance Technologies Overview

## Primary Surveillance Radar



- 2-D aircraft position can be determined only: range and azimuth to a target are measured only;
- Solid-state transmitter consists of 16/32 power modules;
- Indoor equipment power consumption is about 5 KW;
- Air-force cooling is required.

# Surveillance Technologies Overview

## Secondary Surveillance Radar



- Tx signal is radiated by the antenna in  $F=1030$  MHz frequency band, detected by the aircraft transponder that sends reply down to the radar in  $RF=1090$  MHz frequency band.
- Tx signal of 2.5 KW peak power is enough to communicate with transponders located 256 nmi from the radar site.
- Phase-array antenna of 8 m width is used to properly acquire the signal from an airborne transponder.

- Mode S (“Selected”) surveillance allows to minimize broadcasting signals and reduce signal jamming in 1030/1090 MHz frequency band.
- Mode S (“Selected”) surveillance allows to get extra data from onboard sensors wired to airborne transponder.

# Surveillance Technologies Overview

## Secondary Surveillance Radar

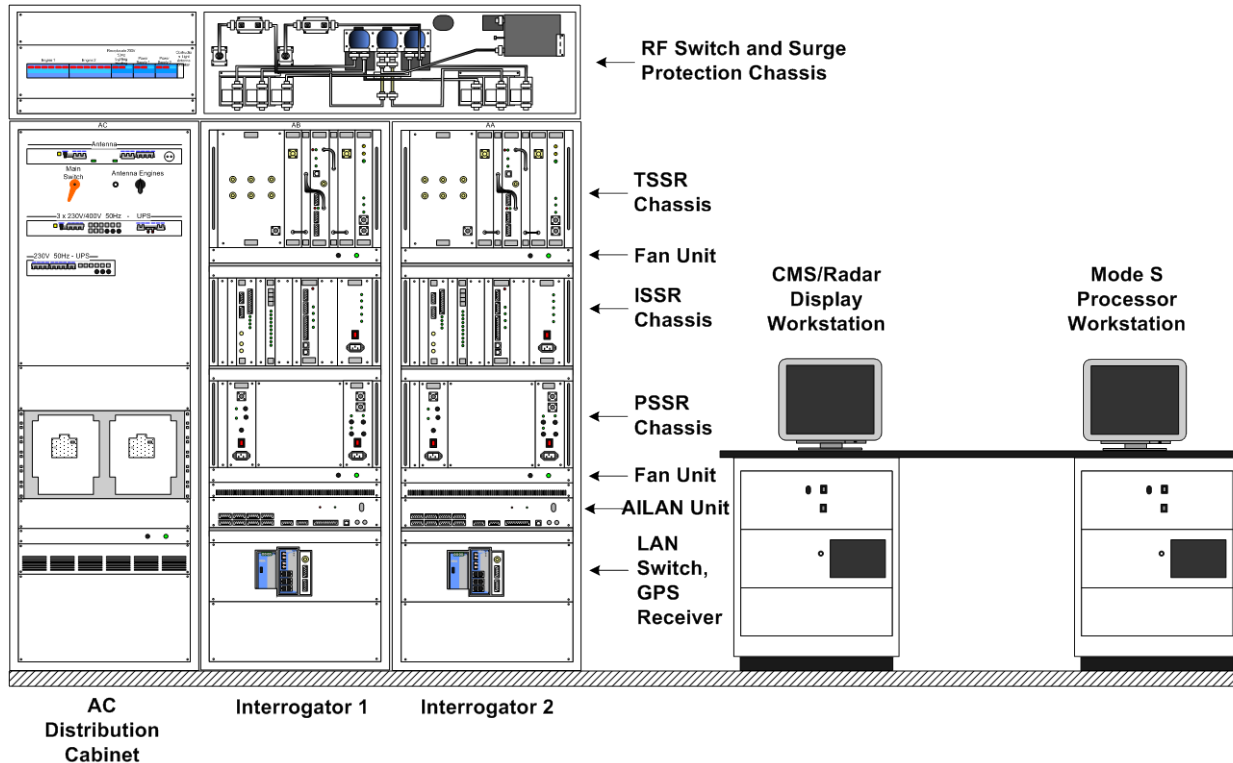

- 3-D position of an aircraft can be determined.
- Two-channel configuration is usually used for redundancy.
- Four 19" cabinets are usually required to house indoor equipment.
- Power consumption of indoor radar equipment is about 1 KW

# Multilateration Technique

- Technique : Calculate position from differences in Time of Arrival at multiple sites

DIFFERENCES BETWEEN  $T_1, T_2, T_3$  can be used to solve simultaneous equations to determine aircraft position, if we know positions of the receivers accurately



- Three receivers are sufficient if aircraft are on the ground
- Four receivers are required if aircraft are airborne

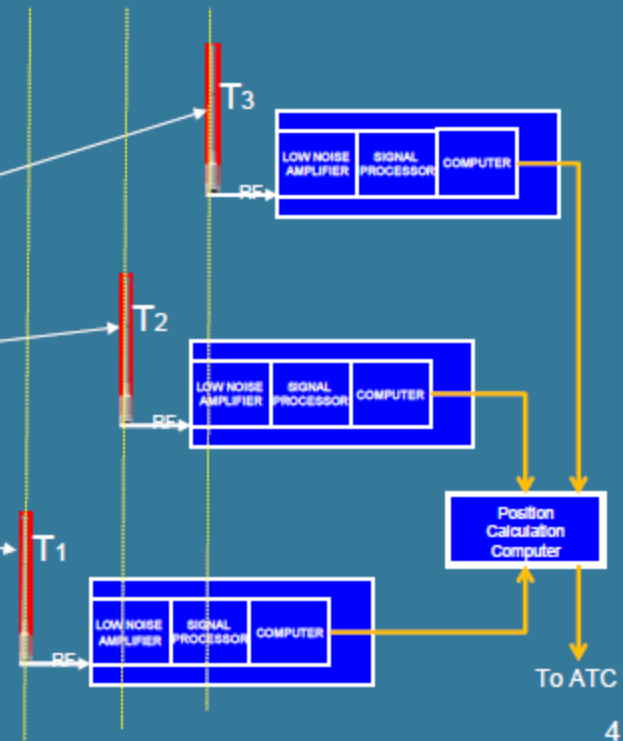

# Graphical Representation

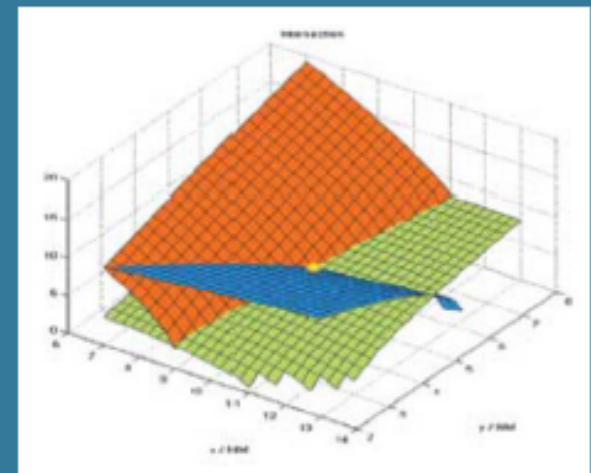
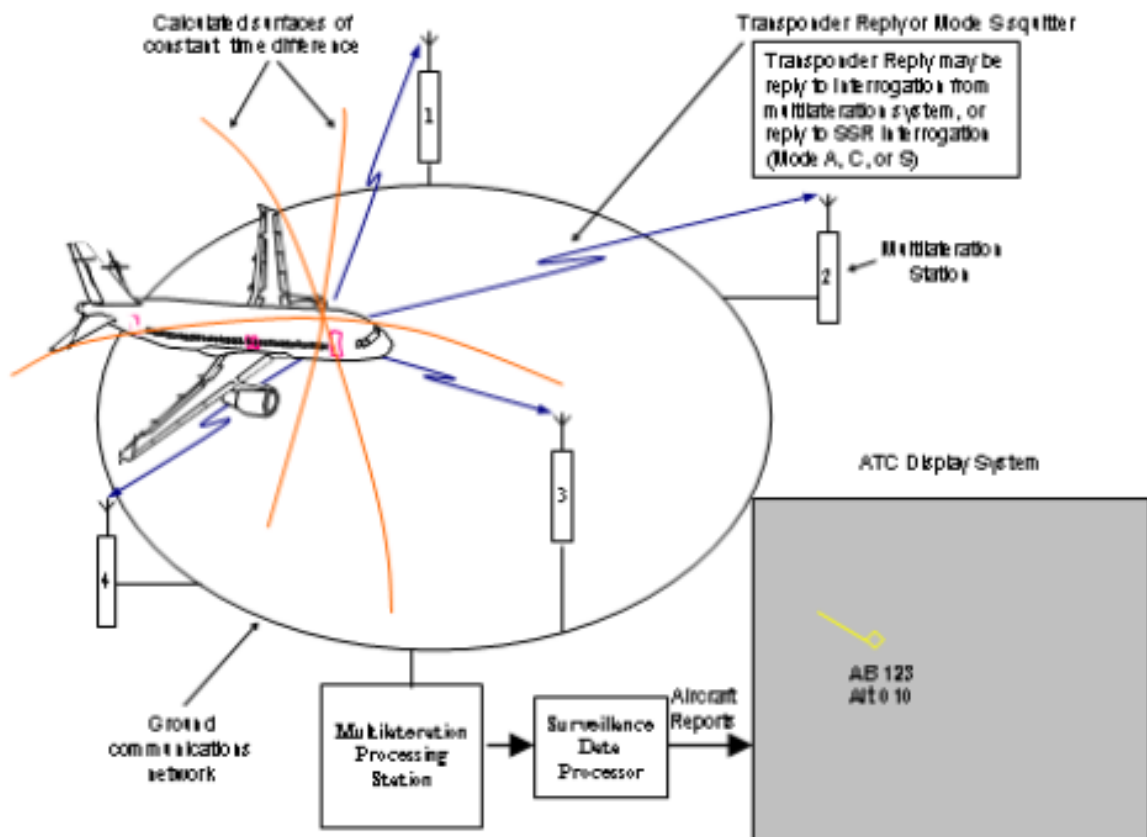

### Transponder Reply or Mode S query

Transponder Reply may be reply to interrogation from multilateration system or reply to SSR Interrogation (Mode A, C, or S)

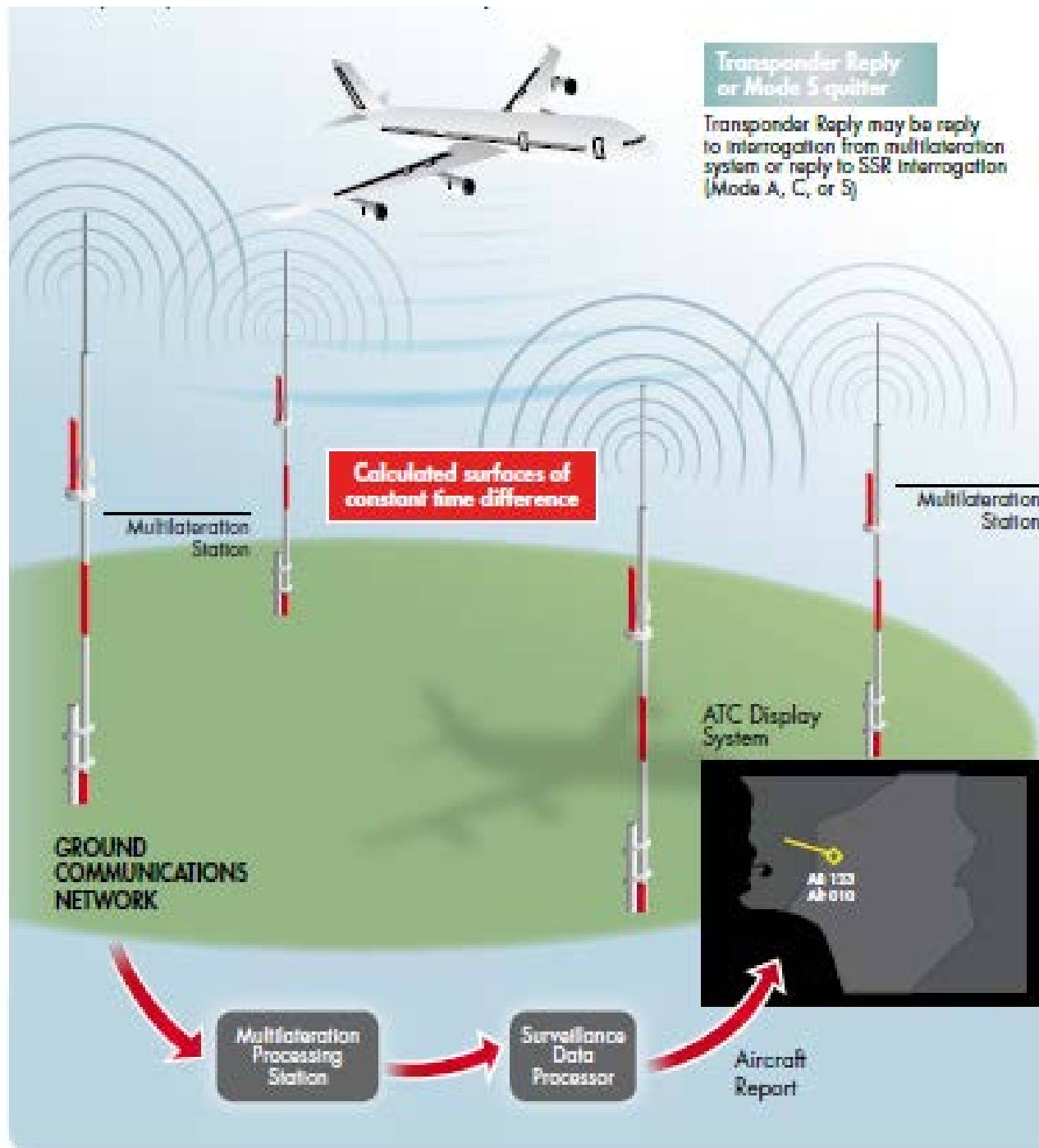

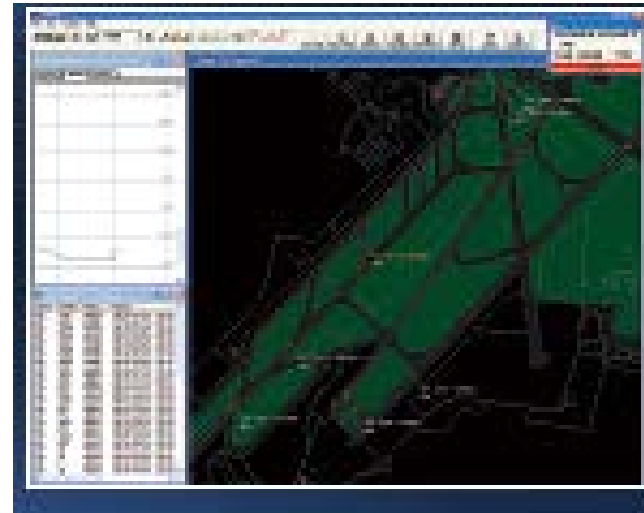

# ADS-B Technology Overview

## Automatic Dependant Surveillance - Broadcast

- On-board navigation systems determines aircraft's position vector (location, time, velocity, intent, if available) and other parameters related to aircraft/flight status.
- The parameters are kept in Binary Data Store (BDS) registers of SSR (ATCRBS) or ADS-B on-board transceivers.
- The transceivers periodically broadcast aircraft/flight status information to ADS-B ground stations and other aircraft equipped with ADS-B equipment.
- ADS-B messages are received by ACAS/TCAS onboard systems to acquire the position of all the aircraft sending ADS-B messages.
- ADS-B messages are received by ADS-B ground stations that derive the aircraft's position from the messages and send the data to ATM Centers.

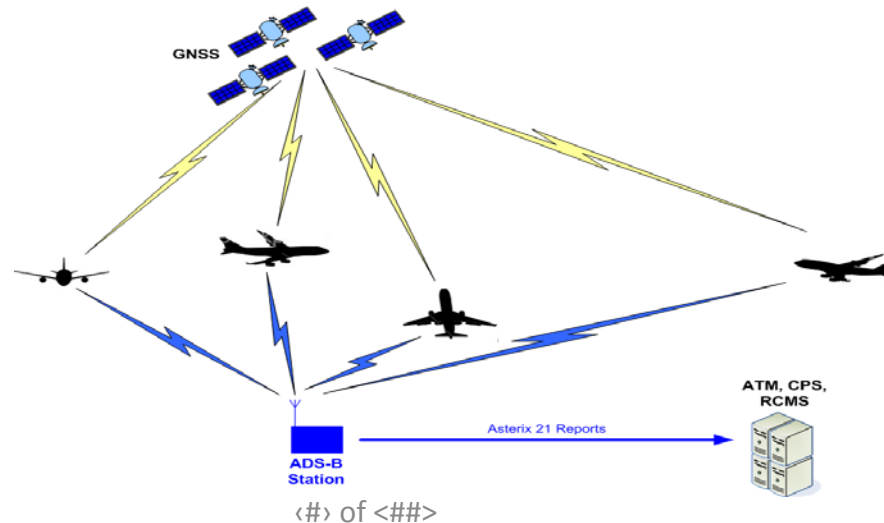

# Surveillance Technologies Overview

## ADS-B Ground Station, Indoor Equipment



- 6U unit, can be mounted on a wall or in 19" rack;
- 160 W power consumption;
- Control and monitoring is handled from local or remote workstation/laptop;
- Two Ethernet lines are available for communication with RDPS.

# Surveillance Technologies Overview

## ADS-B Ground Station, Outdoor Equipment



- Omnidirectional, Gain = 6-9 dBi;
- Length  $L = 2-3$  m, weight  $W = 5-10$  kg;
- LNA is installed close by the antenna terminal;
- Coupler is either built in the antenna or collocated with the LBA enclosure.

# Surveillance Technologies Overview

## Automatic Dependant Surveillance Technology

### Advantages and Limitations

ADS-B technology is advanced in terms of:

- More **precise** position reporting: within 10 m provided GNSS allows
- More **frequent** position update: 1 sec versus PSR/SSR's 4-12 sec
- **Ease of deployment** – significantly less affected by weather, lightweight, low power, with the ability to leverage multiple power sources, including solar power, low-maintenance
- Total **cost** of ownership is significantly less as compared with conventional radars.
- Allows to expand surveillance **coverage** to areas where radar installation is not appropriate.

ADS-B technology limitation:

- Relies on the functionality of Global Navigation Satellite System that might have degraded performance.

# ADS-B Technology Overview

## Transitional Surveillance Technologies

### Integration with SSR and ADS-B Surveillance Sensors

- Traffic Information Services – Broadcast (TIS-B):

Derives traffic information from radar sources and uplinks this traffic information to ADS-B-equipped aircraft. TIS-B enables ADS-B-equipped aircraft to receive position reports on non-ADS-B-equipped aircraft during the transition period to full ADS-B equipage.

- Flight Information Services – Broadcast (FIS-B):

This is an uplink service that provides aeronautical and flight information such as textual and graphical weather reports and Notices to Airmen.

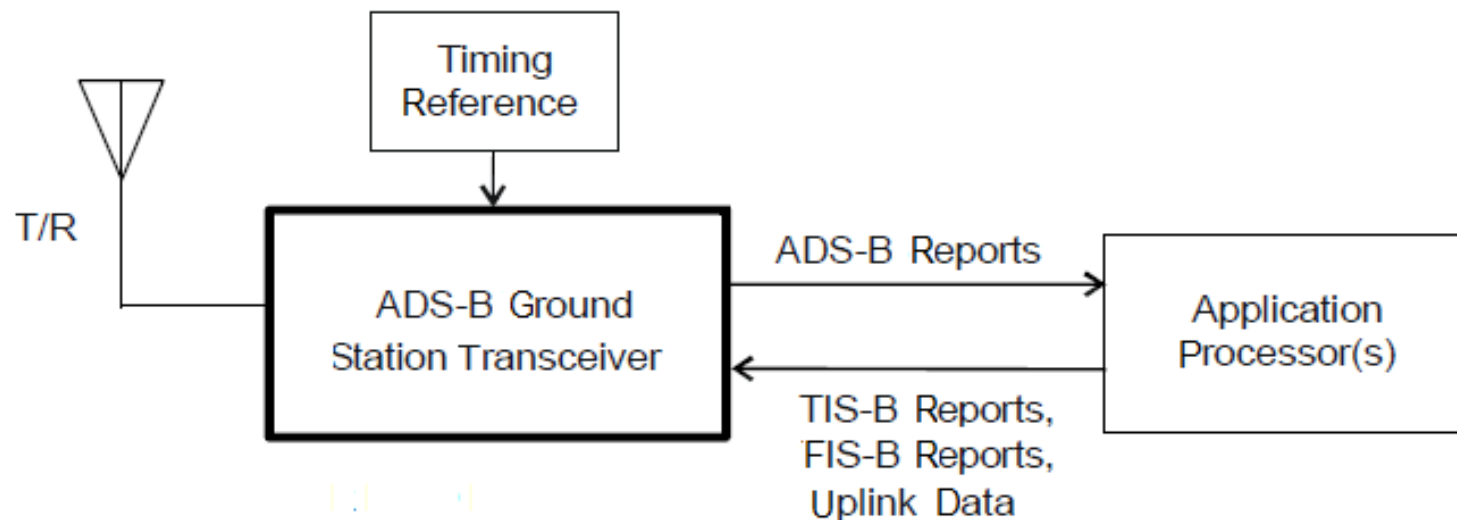

# Traffic Information Service Broadcast (TIS-B)

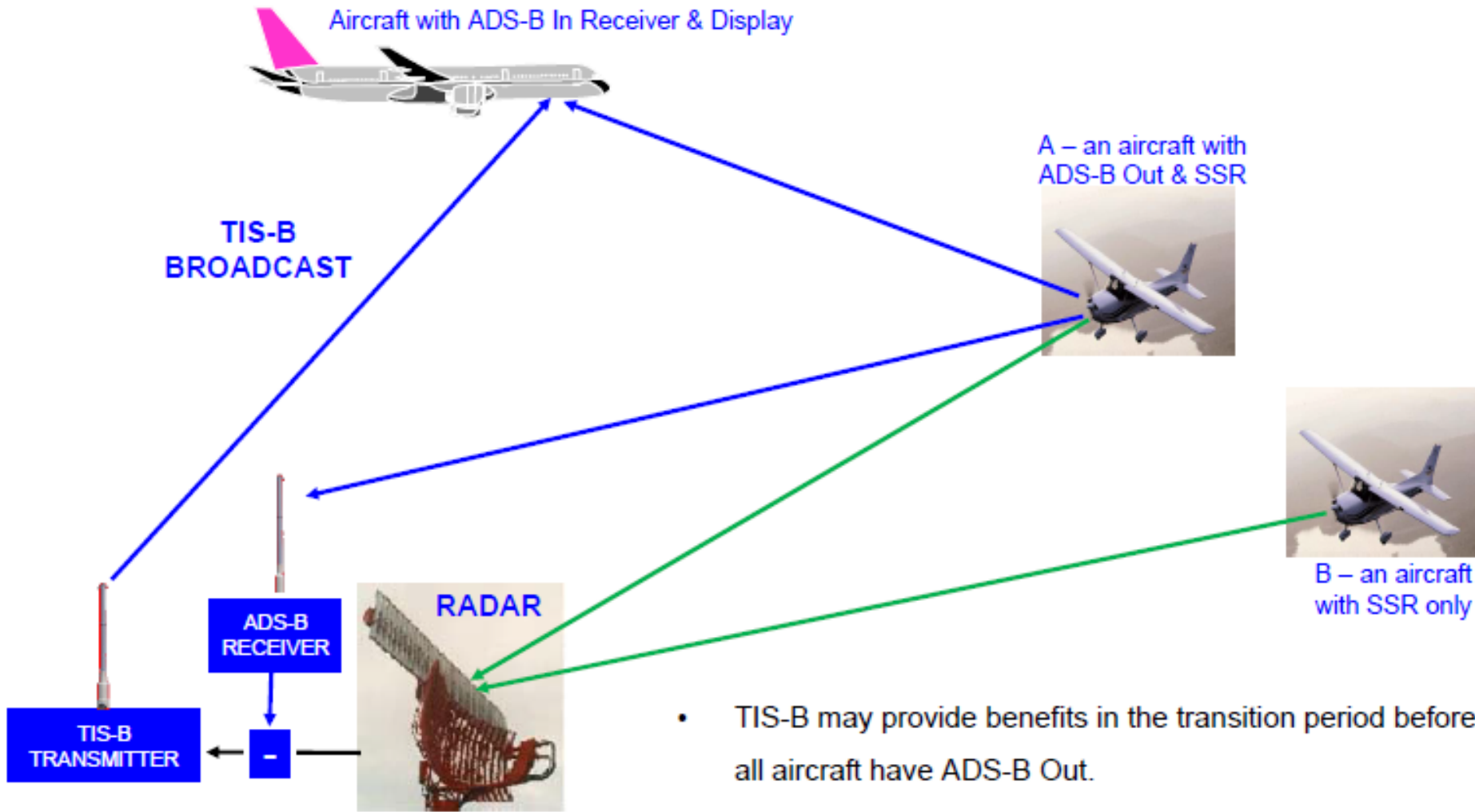

**Solution – receive ADS-B from A on the ground and remove it from the radar data (adds complexity)**

- TIS-B may provide benefits in the transition period before all aircraft have ADS-B Out.
- When all aircraft have ADS-B Out, TIS-B will be discontinued.

# APPLICATIONS

- Aeronautical surveillance systems are designed to be used by ATS to improve capacity and to enhance safety.
- In support of applications, the ATS surveillance system should provide for a continuously updated presentation of surveillance information, including position indications.

# SERVICES

- **AREA CONTROL –**

- A surveillance system for area control typically needs to provide surveillance over large volumes of airspace including remote areas where ground infrastructure may be limited or non-existent. (cruise speed, level ).
- EG; ADS-C , SSR, WAM AND ADS-B

- **APPROACH CONTROL –**

- Approach control service is provided to controlled flights arriving or departing from one or more aerodromes. Vectoring may be performed at higher traffic density levels, and changes in altitude and heading are frequent. Arriving traffic may be placed in holding patterns when demand for services exceeds the aerodrome or airspace capacity.(lesser minima, slower speeds than in en-route).  
Eg; PSR/SSR/MLAT/ADS-B.

# SERVICE

- **AERODROME CONTROL :**

- Visual sighting of aircraft from the control tower is the primary means of determining position. During busy periods and in low visibility conditions, a surveillance system may be used to improve the safety and efficiency of aerodrome operations.
- Surveillance systems suitable for aerodrome control include primary radar, multilateration and ADS-B.
- Other surveillance systems such as millimetre wave sensors, video systems, induction loops and microwave barriers can be used for limited-zone coverage or in cluster to provide wider coverage.

- **ALERTING –**

- Surveillance data should be presented in a manner to support alerting service and, if necessary, search and rescue. This could include a display of position data and data recording. Replay of recorded data should be possible on maps or other means to extract absolute position information.

# SUMMARY

- Aeronautical surveillance systems are major elements of modern air navigation infrastructure and are required to safely manage increasing levels and complexity of air traffic.
- The ability to accurately determine, track and update the position of aircraft has a direct influence on the **minimum distances by which aircraft must be separated.**

# SUMMARY

- In most cases, an aeronautical surveillance system provides its user with knowledge of “who” is “where” and “when.”
- As a minimum, the aeronautical surveillance system provides position information on aircraft or vehicles at a known time.

# SUMMARY

## **ICAO Surveillance strategy.**

- PSR
- 
- SSR
- 
- ADS-B
- 
- MLAT

## **SURV. CATEGORIES**

- Independent
- Co-operative
- Dependent
- Co-operative

# SUMMARY

- **PSR** - Tx signal is radiated by the antenna, reflected back by aircraft body and detected by the radar receiver. (Range and Bearing.)
- **SSR** - Tx signal is radiated by the antenna in F=1030 MHz frequency band, detected by an aircraft transponder that sends reply down to the radar in RF=1090 MHz frequency band.(Range, bearing, other ADD).
- **ADS-B** On-board navigation systems determines aircraft's position vector (location, time, velocity, intent, if available) and other parameters related to aircraft/flight status.
- **MLAT** – Several Rx on the ground receive Transponder replies and calculate A/C position. (3/4 RX plus 1Tx)

# SUMMARY

- **APPLICATION:**
- SERVICES:
- AREA CONTROL
- APPROACH CONTROL
- AERODROME CONTROL
- ALERTING SERVICES
- Air -Traffic Advisory
- OTHERS – ACAS, RVSM –height monitoring, noise monitoring.

# QUESTIONS



# ADS-B

## ADS-B technology overview

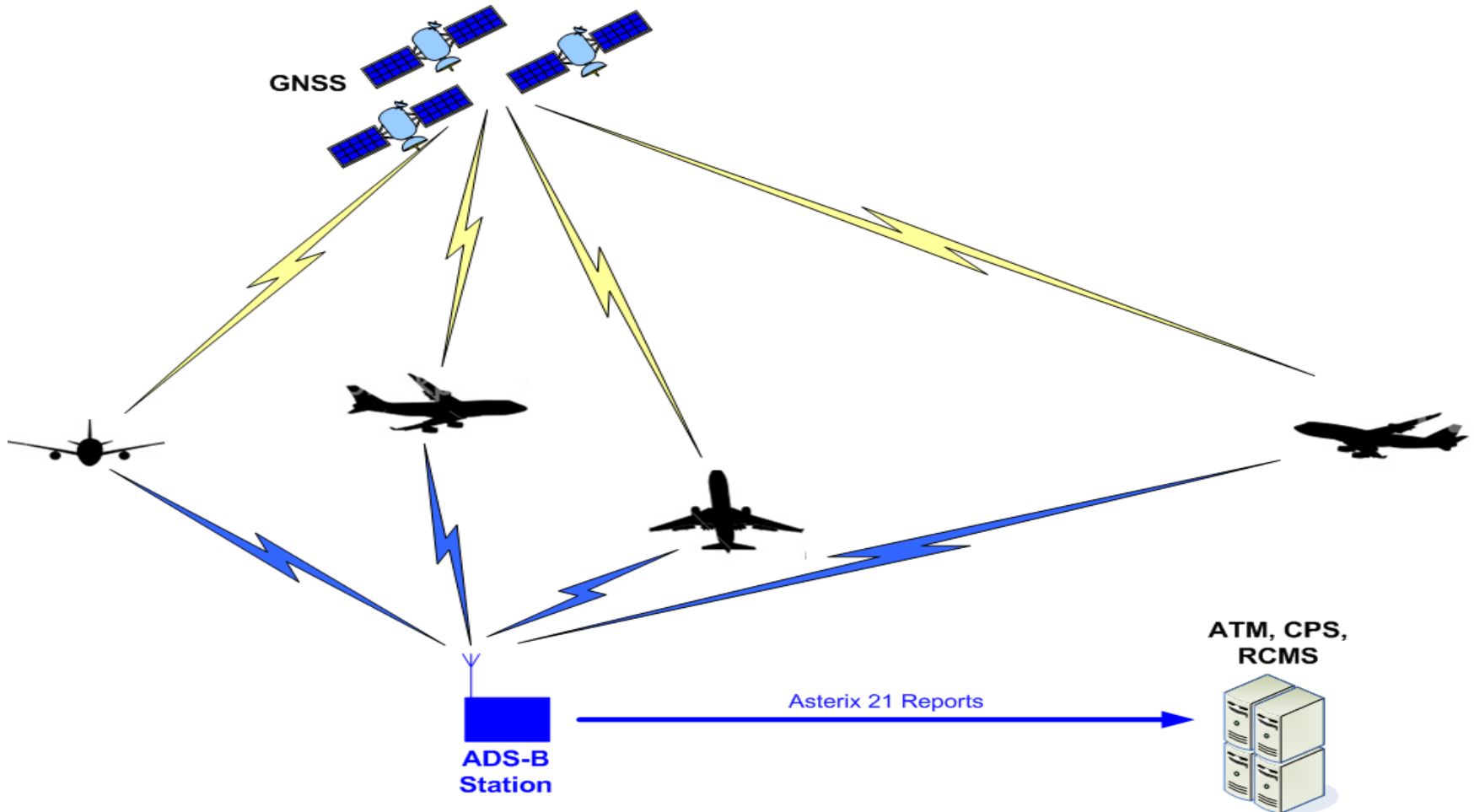



Global Navigation Satellite System



Aircraft uses GNSS and/or (in future) inertial navigation sensors to determine its position.



ADS-B Messages



ADS-B Messages

ATC Display System

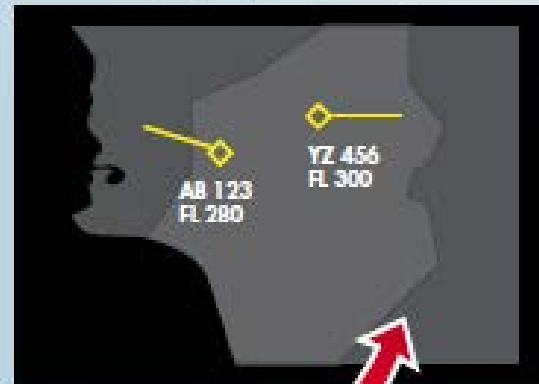

ADS-B GROUND STATION

Surveillance Data Processor

Aircraft Reports

Global Navigation  
Satellite System

# How ADS-B works.

- Aircraft tell everybody who can listen who they are, where they are, where they are going and at what speed.

ADS-B  
Messages

ATC Display System

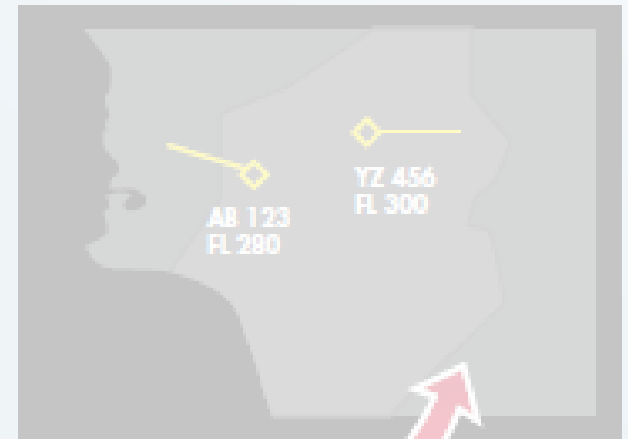

ADS-B  
Messages

ADS-B  
GROUND  
STATION

Surveillance  
Data  
Processor

Aircraft  
Reports

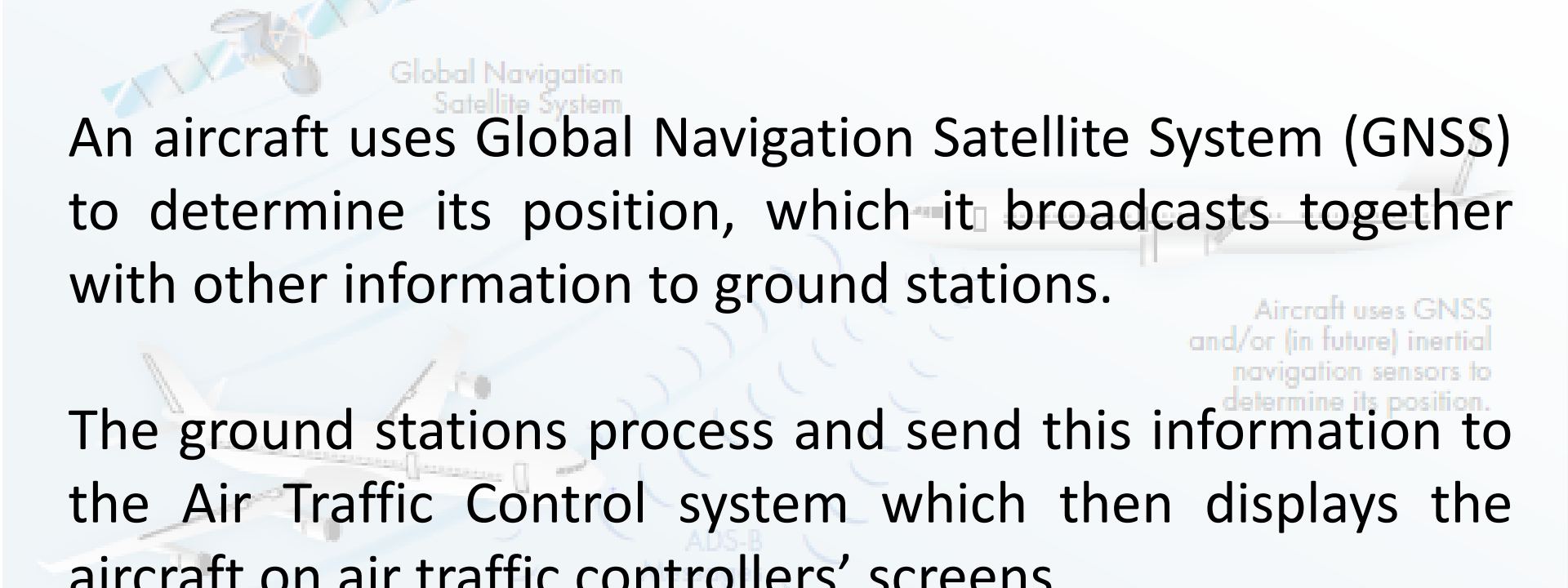

An aircraft uses Global Navigation Satellite System (GNSS) to determine its position, which it broadcasts together with other information to ground stations.

The ground stations process and send this information to the Air Traffic Control system which then displays the aircraft on air traffic controllers' screens.

ADS-B equipped aircraft broadcast once per second their position and other information without any intervention from ground systems.

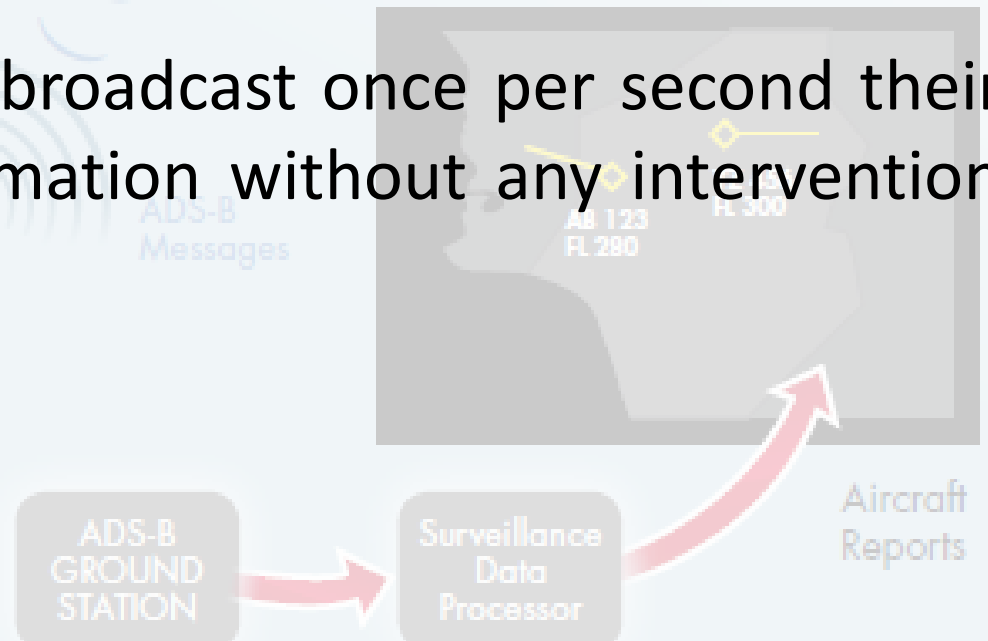

# SBAS

Geosatellite

Integrity data & corrections downlinked to aircraft

Integrity data & corrections uplinked

Signals from GPS satellites

Uplink station

Master control station

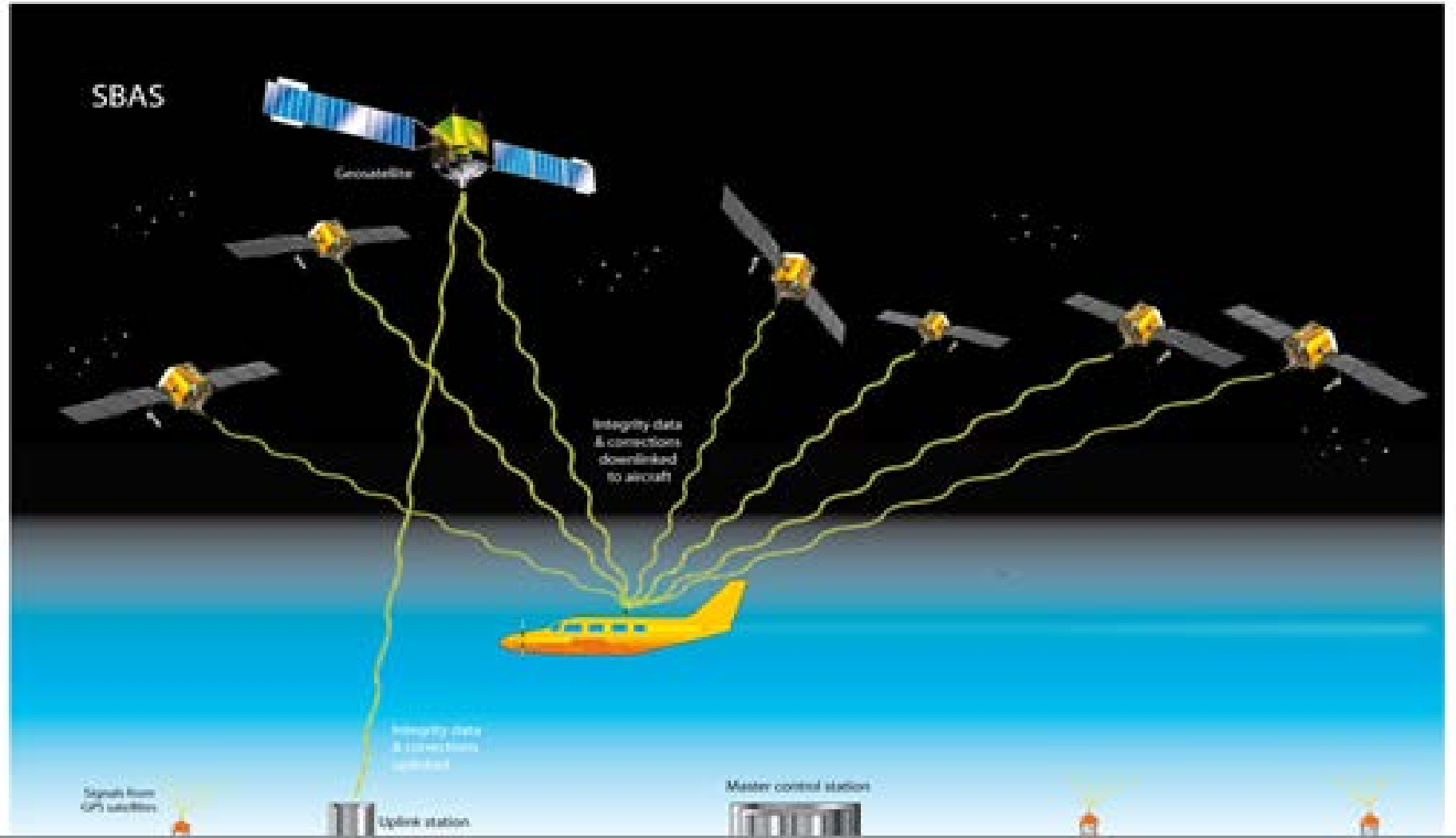

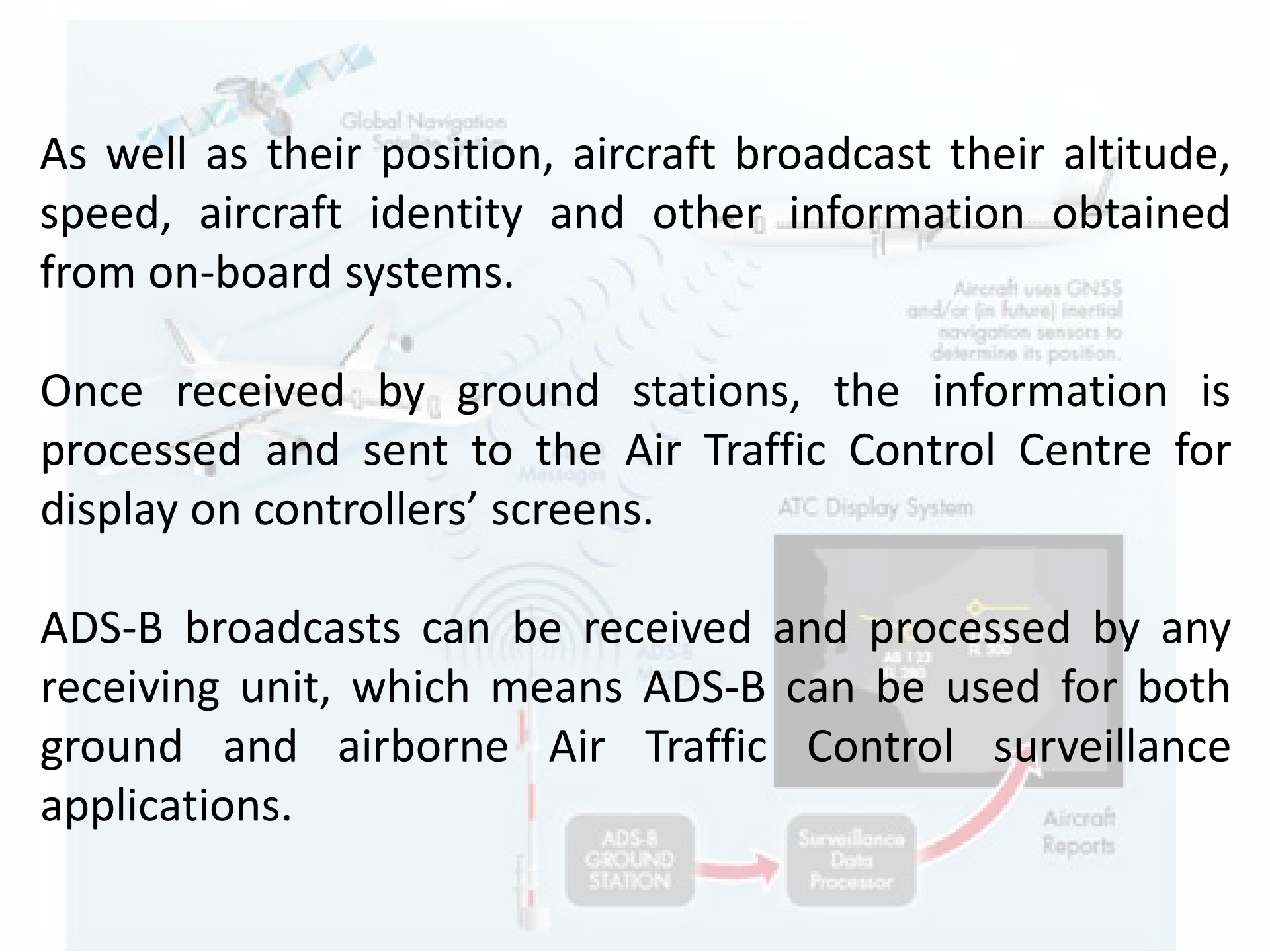

As well as their position, aircraft broadcast their altitude, speed, aircraft identity and other information obtained from on-board systems.

Once received by ground stations, the information is processed and sent to the Air Traffic Control Centre for display on controllers' screens.

ADS-B broadcasts can be received and processed by any receiving unit, which means ADS-B can be used for both ground and airborne Air Traffic Control surveillance applications.

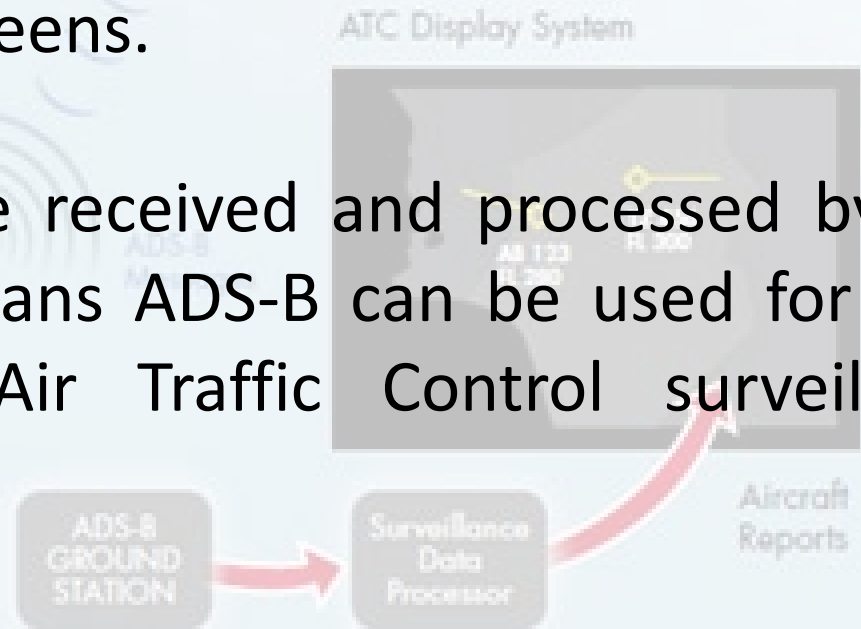



# Mode S Extended Squitter

Squitter is reply-format transmission without being interrogated. **“Unsolicited”** replies are used by TCAS 2-equipped aircraft to acquire the ICAO address of squittering airframes.

Mode S technology uses short (56 bits) acquisition and long (112 bits) extended squitters.



# Mode S Extended Squitter

Extended Squitter (ES) is an enhanced feature of Mode S transponders and is a further extension of legacy surveillance technologies.

Mode S ES capable transponders send unsolicited periodic ADS-B messages that provide aircraft's position, velocity, time and other relevant information derived from on-board avionics navigation systems.

ES messages are received by ACAS/TCAS systems to acquire the aircraft equipped with Mode S ES transponders.

**ES messages are received by ADS-B ground stations that derive aircraft's position from ES messages and send the data to ATM Centers.**



# ADS-B Technology Overview

## ADS-B Mode S Extended Squitter Data Block Structure



1. Control Group
  - 3-bit Transponder Capability Report ;
2. 24-bit ICAO Aircraft Address – unique aircraft identification;
3. 56-bit Message Extended Squitter Field – the data from transponder’s BDS registers;
4. 24-bit Parity Check – error protection.

# ADS-B Mode S Extended Squitter On-board Equipment

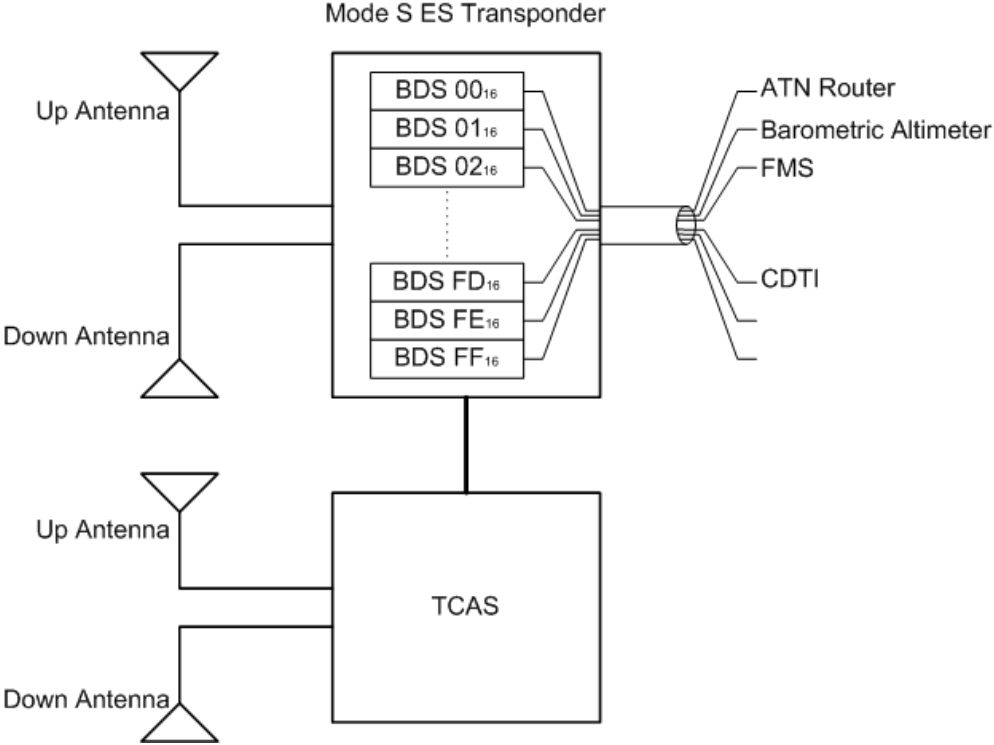

# KT 74

ADS-B OUT ENABLED MODE S TRANSPONDER



## 1.2 FRONT PANEL CONTROLS AND FUNCTIONS



Figure 1-1: Front Panel Controls and Functions

The KT 74 has the following front panel controls and functions:

- **Display:** See section 1.3.
- **Mode Knob:** See section 1.4.
- **Push Buttons:** See section 1.5.
- **Functions:** See section 1.6.

## 1.3 DISPLAY





- OFF** Power is removed from the transponder.
- SBY** The transponder is on, but will not reply to any interrogations.
- ON** The transponder will respond to all interrogations, but altitude reporting is suppressed.
- ALT** The transponder will respond to all interrogations.

When airborne, the transponder should always be set to ALT unless otherwise directed by Air Traffic Control. Aircraft installations that include a gear squat switch or other method of air/ground determination will automatically select surface reporting mode on landing or when taxiing. The mode indicator will read GND.

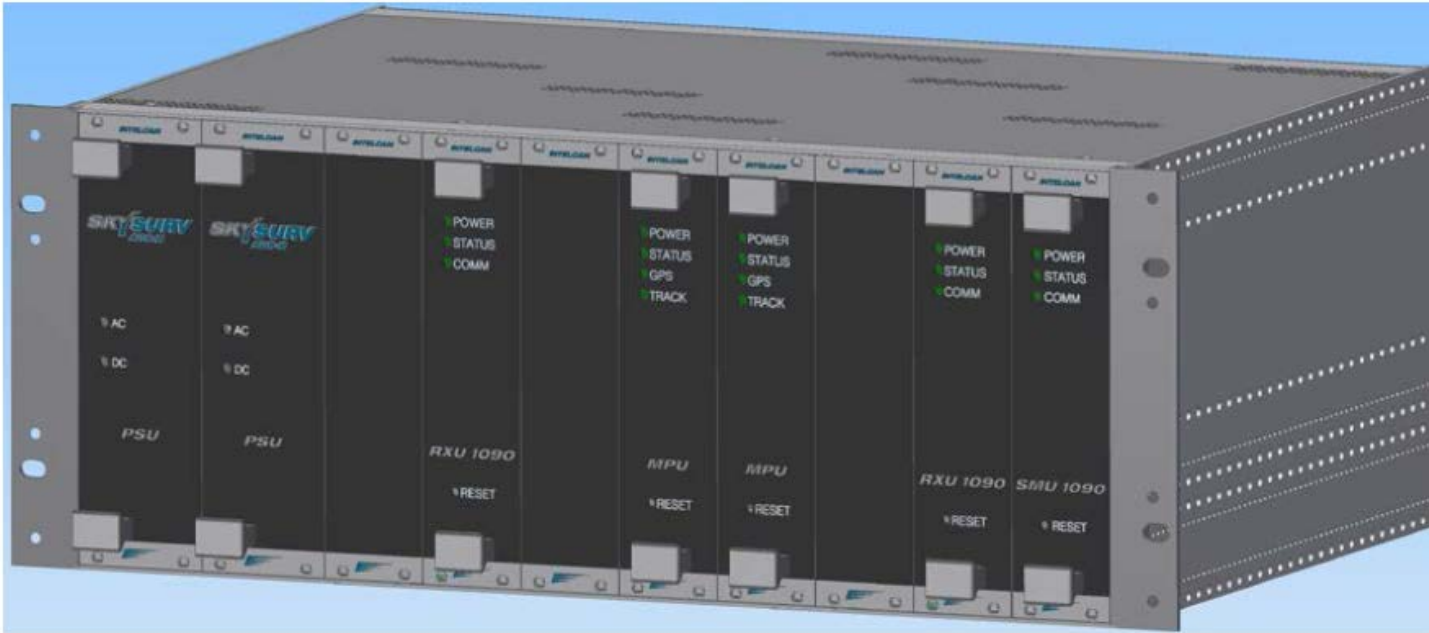

GUYANA

# S7000 ADS-B GROUND STATION DESCRIPTION

# SKYSURV ADS-B Ground Station

## Overview

- **Listens** for Mode S ES messages broadcasted by airborne transponders;
- **Acquires and decodes** messages contents (position, altitude, velocity, callsign,...);
- **Detects** and, when possible, corrects reception errors ;
- **Creates** target tracks and **generates** ASTERIX Category 21 and Category 33 reports based on the processed data;
- **Transmits** the reports via a ground network to Radar Data Processing System (ATM).or SDPS.

## SKYSURV ADS-B Ground Station Line Replaceable Units (LRU)

LRU	S7000 Ground Station Model		
	S7110	S7120	S7121
Processing Unit (MPU)	1	2	2
Site Monitor Unit (SMU)	1	1	1
Receiver 1090 MHz (RXU 1090)	1	2	2
Power Supply Unit (PSU)	1	2	2
Antenna	Omni	Omni	Sector 180°

- Low Noise Amplifier (LNA) is integral part of S7000 Ground Station. The LNA is mounted close to antenna terminal in order to minimize receiver sensitivity degradation due to RF feeder between the antenna and the Ground Station chassis.
- Coupler is provided in front of the LNA to verify the integrity of RF front-end of the station.
- Dual LRUs are assembled, when required, for redundancy.

# SKYSURV ADS-B Ground Station

## Block Diagram

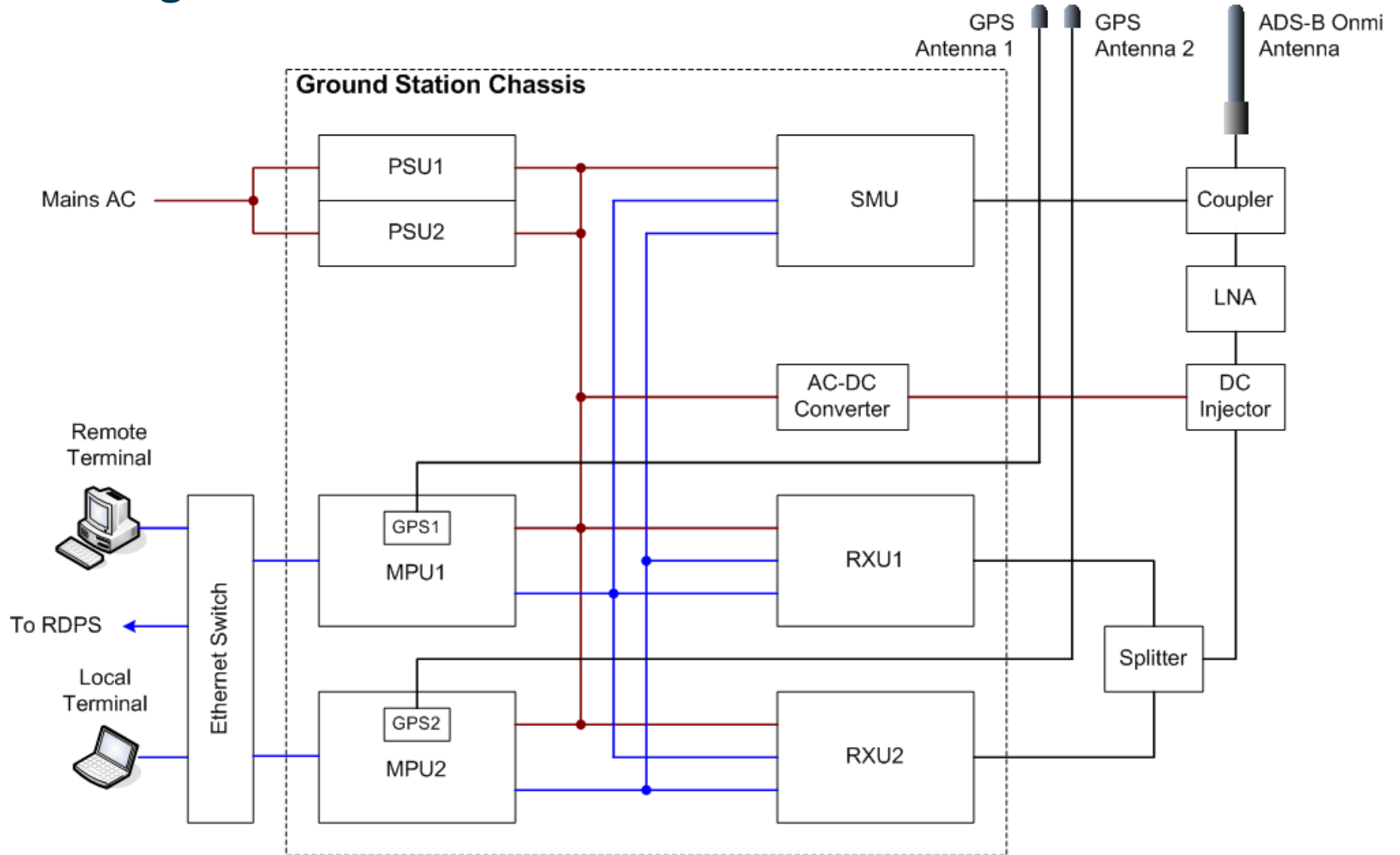

# SKYSURV ADS-B Ground Station

## Data Flow Diagram

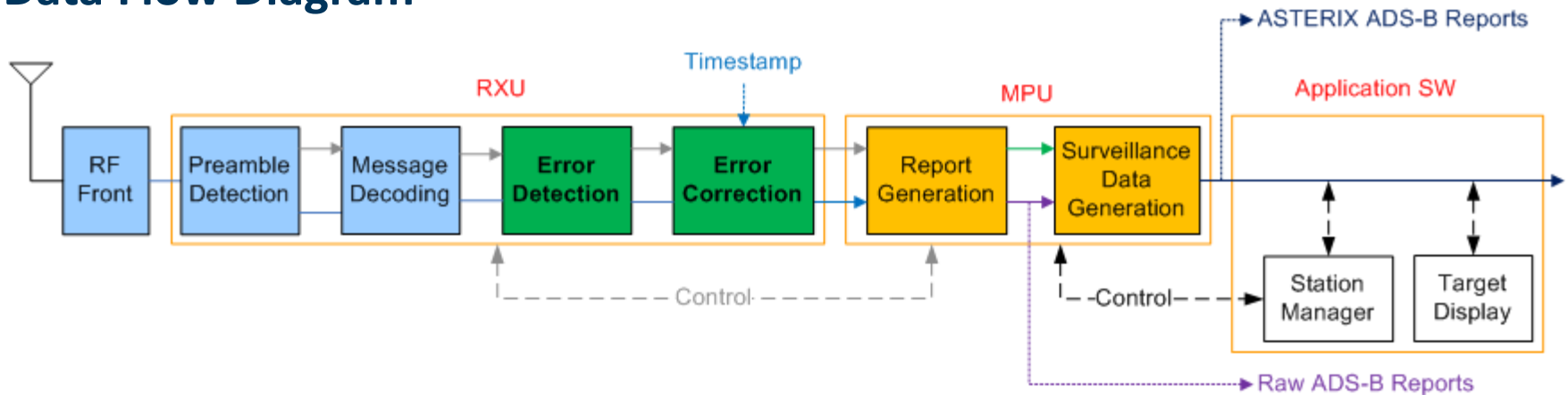

All Mode S messages defined in RTCA standards DO-260/A/B are decoded:

- DF 17
- DF 18
- DF 19 (military)

In addition, the station is capable of decoding the SSR downlink messages:

- Mode A/C
- Mode-S DF4, DF5, DF11, DF20, DF21

# SKYSURV ADS-B Ground Station Description

## Specifications

Input signal	1090 MHz Mode S Extended Squitter
Sensitivity	Better than -90 dBm @ LNA input
Decoder	Compliant with RTCA DO 260/260A
Output signal format	ADS-B raw data, ASTERIX Category 21
Target capacity	> 500 tracks
Operational range	> 250 nmi
Processing capacity	4000 Extended Squitter messages per second
Electrical Interfaces	Ethernet, RS-232 Synchronous
External Interface Protocols	TCP/IP, UDP/IP, SNMP, NTP, Synchronous Serial
Power Supply	90-260 VAC 50-60 Hz, or 24 VDC (+/- 4 V)
Power consumption	< 160 W in generic configuration

Module 5

# **ADS-B REPORT ASSEMBLY**

## SKYSURV ADS-B Ground Station

### ADS-B Message Processing Overview

- The ground station uses the **Globally Unambiguous Airborne Position** Decoding method described in the reference standards DO-260 and DO-260A to establish target position initially.
- Once the aircraft's position is established, the **Emitter Centered Local Decoding** method is used to update the airborne position of aircraft on reception of each subsequent **odd or even** format messages.
- MPU generates tracks and then maintains **tracks** for target which the MPU is receiving valid ADS-B broadcasts periodically.
- MPU filters out messages with unreasonable position information (jumps due to aircraft's position reporting errors) and re-initializes the global decoding.

## SKYSURV ADS-B Ground Station

### ADS-B Reports Generation

ADS-B reports are generated in ASTERIX format (Category 21) and raw data format.

The Ground Station delivers ADS-B reports at the following rates:

- Airborne position: every 0.5 sec;
- Ground position: every 0.5 sec if the aircraft is moving, otherwise every 5 sec;
- Identification and aircraft type: every 5 sec;
- Velocity and the accuracy quality indicator: every 0.5 sec;
- Aircraft status, including quality indicators, as necessary: every 1.25 sec;
- Emergency messages: every 8 sec.

# SKYSURV ADS-B Ground Station

## ADS-B Reports Generation

- The station has very flexible and configurable delivery mechanisms ensuring that the reports to RDPS application meet customer requirements. Data can be output to multiple destinations whether in UDP or TCP.
- The station may also be configured to either send or not send to the RDPS the reports for the targets, which parameters are falling in the range of values set in manually configured filters:
  - messages based on MOPS version;
  - "on ground" or airborne targets;
  - aircraft address;
  - figure of merit;
  - altitude range;
  - coverage range;
  - received signal strength threshold.
- The targets, which are excluded from the delivery pool, are still being recorded by the MPU's.

Last Update (local host)	15:04:28
Time Of Day	19:17:43
Data Source	SAC=247, SIC=1
ICAO Address	3434CA
Flight ID	IBE6651
Latitude	6.435993
Longitude	-57.917798
Altitude	36000
Ground speed	476.08
Track angle	186.6
Vert Rate	0
Emitter Category	
▼ Figure Of Merit	
NACv	0
NIC	8
▼ Target Status	
Priority Status	No Emergency/Not Reported

# SKYSURV ADS-B Ground Station Target Display GUI

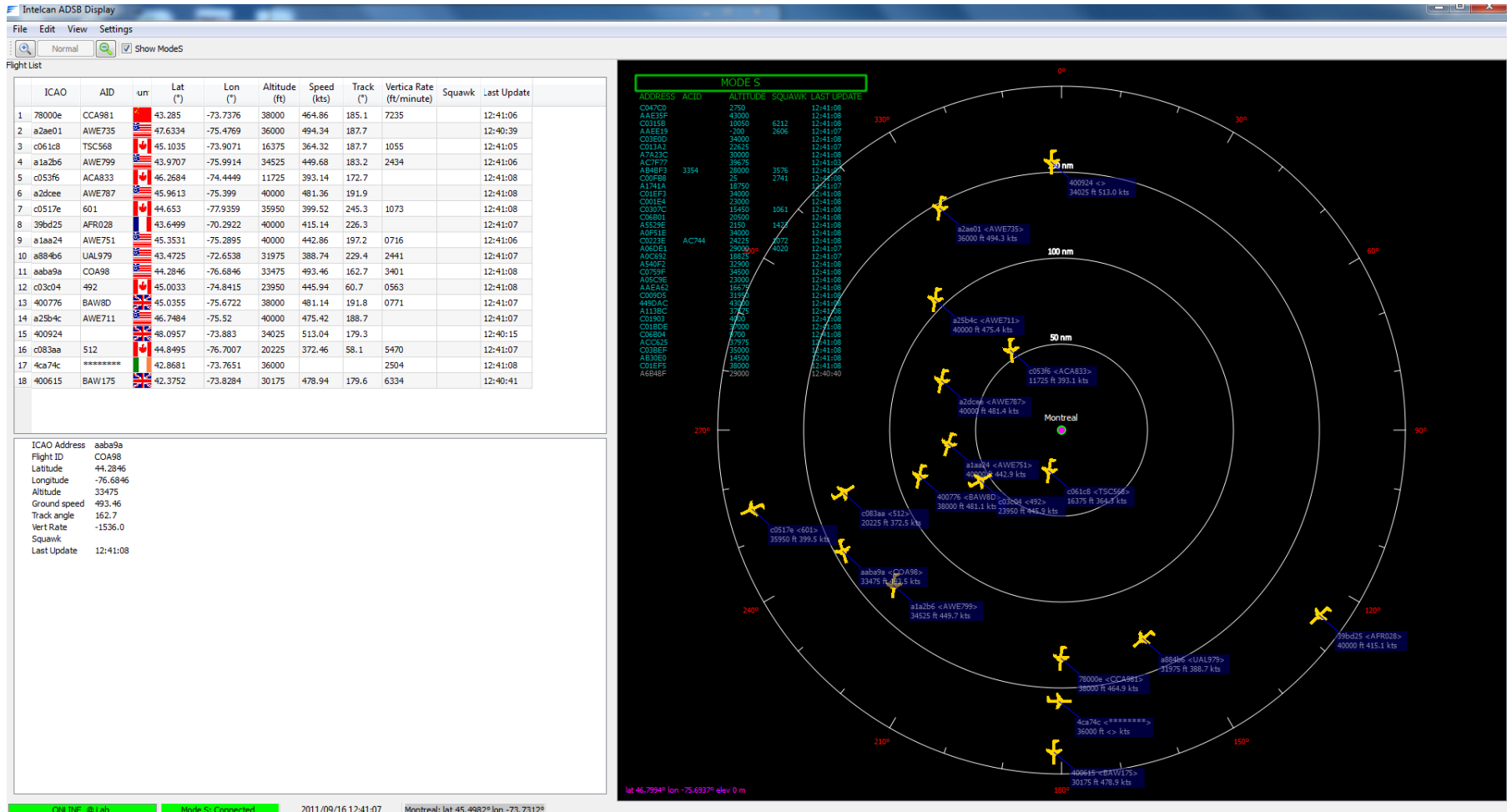

# SUMMARY

- **1090 MHz Mode S Extended Squitter (ES)** – recommended by ICAO as a global primary link for ADS-B systems.
- **Squitter** is reply-format transmission **without being interrogated**.
- **Mode S ES capable transponders** send unsolicited periodic ADS-B messages that provide aircraft's position, velocity, time and other relevant information derived from on-board avionics navigation systems.

8-bit Control Group	24-bit ICAO Aircraft Address	24-bit Parity Check
---------------------	------------------------------	---------------------

8-bit Control Group	24-bit ICAO Aircraft Address	56-bit ADS-B Message	24-bit Parity Check
---------------------	------------------------------	----------------------	---------------------

# SUMMARY

## 1.3 DISPLAY



# SUMMARY

- **Listens** for Mode S ES messages broadcasted by airborne transponders;
- **Acquires and decodes** messages contents (position, altitude, velocity, callsign,...);
- **Detects** and, when possible, corrects reception errors ;
- **Creates** target tracks and **generates** ASTERIX Category 21 and Category 33 reports based on the processed data;
- **Transmits** the reports via a ground network to Radar Data Processing System (ATM).or SDPS

# SUMMARY

- RX – SPECS.
- Target capacity > 500 tracks
- Operational range > 250 nmi
- Processing capacity
- 4000 Extended Squitter messages per second

# SUMMARY

## POSITION & UPDATE.

### Globally Unambiguous Airborne Position -1<sup>st</sup>

- Once the aircraft's position is established, the **Emitter Centered Local Decoding** method is used to update the airborne position of aircraft on reception of each subsequent **odd or even** format messages.

Airborne position: every 0.5 sec;

Ground position: every 0.5 sec if the aircraft is moving, otherwise every 5 sec;

Identification and aircraft type: every 5 sec;

# QUESTIONS



ATM

FLIGHT PLANNING.

# AMDT 1 –DOC.4444

- **4.4.1 Flight plan form**
- **APPENDIX 2. FLIGHT PLAN**
- **ITEM 10: EQUIPMENT AND CAPABILITIES**
- Capabilities comprise the following elements:
- a) presence of relevant serviceable equipment on board the aircraft;
- b) equipment and capabilities commensurate with **flight crew qualifications**; and
- c) where applicable, authorization from the appropriate authority.

# FPL –ITEM 10b.

- Surveillance equipment **and capabilities**
- *INSERT N - if no surveillance equipment for the route to be flown is carried, or the equipment is unserviceable;*
- one or more of the following descriptors, to a maximum of 20 characters, to describe the **serviceable surveillance equipment** and/or capabilities on board:

## **ADS-B**

B1 - ADS-B with dedicated 1 090 MHz ADS-B “out” capability

B2 - ADS-B with dedicated 1 090 MHz ADS-B “out” and “in” capability

U1 - ADS-B “out” capability using UAT

U2 - ADS-B “out” and “in” capability using UAT

V1 - ADS-B “out” capability using VDL Mode 4

V2 - ADS-B “out” and “in” capability using VDL Mode 4

## **ADS-C**

D1 - ADS-C with FANS 1/A capabilities

G1 - ADS-C with ATN capabilities

Alphanumeric characters not indicated above are reserved.

Example: ADE3RV/HB2U2V2G1

# ATS Wizard



Date of Flight 13/05/13  +1  +3  +24 hrs

10/ Radiocommunication

SVOLE1J1M1RDGI

Surveillance Equipment

S

STS/ALTRV PBN/B1O IT1 DOF/130513

18/ Other Info

# SURV.

STS/

Altitude reservation

COM/

### Equipment and Surveillance

- NIL  +
  - VHF RTF/VOR/ILS
  - (A) GBAS
  - (B) LPV APV/SBAS
  - (C) LORAC
  - (D) DME
  - (F) ADF
  - (G) GNSS
  - (H) HF RTF
  - (I) INERTIAL NAV
  - (K) MLS
  - (L) ILS
  - (O) VOR
  - (T) TACAN
  - (U) UHF RTF
  - (V) VHF RTF
  - (W) RVSM
  - (X) MNPS
  - (Y) VHF 8.33
  - (Z) OTHER
- ACARS
  - (E1) FMC WPR
  - (E2) D-FIS
  - (E3) PDC
  - CPDLC
  - (J1) ATN VDL Mode 2
  - (J2) FANS 1/A HFDL
  - (J3) FANS 1/A VDLMode A
  - (J4) FANS 1/A VDLMode 2
  - (J5) INMARSAT
  - (J6) MTSAT
  - (J7) IRIDIUM
  - ATS RTF SATCOM
  - (M1) INMARSAT
  - (M2) MTSAT
  - (M3) IRIDIUM
- NIL  +
  - (A) MODE A
  - (C) MODE A/C
  - (E) S/ID/PALT/ADSB
  - (H) S/ID/PALT/DLINK
  - (I) S/ID
  - (L) S/ID/PALT/ADSB/DLINK
  - (P) S/PALT
  - (S) S/ID/PALT
  - (X) MODE S
  - ADS-B/1090 MHZ
  - (B1) Out Capability
  - (B2) In/Out Capability
  - Uncheck All
  - ADS-B/UAT
  - (U1) Out Capability
  - (U2) In/Out Capability
  - Uncheck All
  - ADS-B/VDL M4
  - (V1) Out Capability
  - (V2) In/Out Capability
  - Uncheck All
  - ADS-C
  - (D1) ADS-C/FANS 1/A
  - (G1) ADS-C/ATN
  - Uncheck All

### RNAV and RNP

- NIL  +
  - (A1) RNAV 10 (RNP 10)
  - RNAV 5
  - (B1) ALL S
  - (B2) GNSS
  - (B3) DME/DME
  - (B4) VOR/DME
  - (B5) INS/IRS
  - (B6) LORAC
  - RNAV 2
  - (C1) ALL
  - (C2) GNSS
  - (C3) DME/DME
  - (C4) DME/DME/IRU
  - RNAV 1
  - (D1) ALL
  - (D2) GNSS
  - (D3) DME/DME
  - (D4) DME/DME/IRU
- NIL  +
  - (L1) RNP 4
  - RNP 5
  - (O1) ALL S
  - (O2) GNSS
  - (O3) DME/DME
  - (O4) DME/DME/IRU
  - Approach
  - (S1) APCH
  - (S2) APCH/BARO NAV
  - Uncheck All
  - AR Approach
  - (T1) AR APCH RF
  - (T2) AR APCH NO RF
  - Uncheck All

SUR/ field should be filled !

DO	221833	TTZPZQZX	SYCJZPZX	(FPL-TAM8111-IS	Thu 01/22/15 18:33:43	715	FPL	38701
FF	221832	SYCJZPFD	SYCJZPZX,SYG...	(FPL-BWA461-IS	Thu 01/22/15 18:32:59	212	FPL	38701
			SYCJZPZX	(FPL-ACA099-IS	Thu 01/22/15 18:32:55	709	FPL	38701

PRI: FF  
 FT: 221833  
 OHI:

(FPL-TAM8111-IS

-B763/H-SDE1E2E3FGHIJ3J5M1RWXYZ/HD1

NO "SURV. FILED

-KMCO1335  
 -NO456F350 DCT TRV BR62V JAKEL/M078F350 BR62V ZFP BR1L GTK L452  
 ANADA UG449 POS/NO459F350 UA324 ORANI/NO458F370 UA324 TIM UA312  
 ACARI UZ52 FRM UZ38 MOXEP ANSUG1A  
 -SBGR0825 SBGL  
 -PBN/ALB1D1L101S2 NAV/RNVD1E2A1 DAT/SV DOF/150122 REG/PTMSX  
 EET/KZMA0003 MYNA0023 KZMA0025 ZFPO026 BARTS0035 MAMMLO041  
 DIAZZ0051 COBBL0052 LOGVNO055 BRRGO0057 AVNEY0102 BENIE0106  
 OREDE0116 RAHAM0118 STRUDO120 BIKINO124 GTK0128 RNTRY0135  
 MACKI0140 HARBG0146 TJZS0147 MUNOZO156 BQNO202 ETEEE0220 RAFEE0224  
 TTZP0235 SVZMO325 SYGC0328 SMPMO404 SBAZO429 SBBS0619 SBCW0824  
 SEL/KREF CODE/E48E70 OPR/TAM RIF/FRM UW10 BSI DCT SBBR RMK/TCAS)

FF	221832	SYCJZPFD	SYCJZPZX	(FPL-ACA099-IS	Thu 01/22/15 18:32:33		
GG	221832	SYCJZPFD	SYCJZPZX	(FPL-ACR480/A1262...	Thu 01/22/15 18:32:42	609	FPL 387009

PRI: GG  
FT: 221832  
OHI:

(FPL-ACR480/A1262-IS  
-B772/H-SDE2E3FGHIJ3J5J6M1M2RWXYZ/LB1D1

SURV. FILED



-LFPG1245  
-N0493F330 DCT LGL UT176 TERPO UN461 AKEMO UN471 COQUE/M084F340 UN471  
LAPEX UN470 SEPAL/M084F340 DCT PASAS/M084F340 DCT 44N015W 41N020W  
34N030W 27N040W 1800N04905W 17N050W/M084F360 DCT TRAPP/N0491F360  
UM527 DOBDA/N0486F380 UM527 TEMOR/N0480F400 UM527 VADOS VADOS1  
-SPIM1151 SPSO  
-PBN/A1B1C1D1S1L1 NAV/RNVd1E2A1 DOF/150121 REG/FGSPN EET/LFRR0023  
EGGX0109 LPPO0134 015W0146 020W0221 030W0338 KZNY0501 TTZP0632  
17N050W0642 SMPM0756 SYGC0808 SBAZ0843 SPIM1101 SEL/EHLR OPR/AFR  
RALT/LPLA TBPB)

# Sep. App

- a) when two aircraft are flying at a given separation, they are not in a collision situation. Similarly, when two aircraft are seen at the given minimum separation, they will not be closer than a minimum specified buffer at any time during the period of display;
- b) the application considered corresponds to a buffer size equivalent to the maximum aircraft size. It does not cover wake turbulence separation minima for which there may be a need to specify different buffers;
- c) the system shall be able to support the display of aircraft trajectories and to distinguish between aircraft; and
- d) separation is only provided between identified aircraft.

# Data item needed for sep.

- *Horizontal position.*
- a) range and azimuth (typically provided by radars);
- b) latitude and longitude (typically provided by an ADS-B system); or
- c) a specific system of X and Y coordinates (as may be provided by a multi-sensor tracker).

# Data item needed for sep.

- **Pressure altitude (also known as barometric altitude).**
- This data item is derived from the altimeter of the aircraft and is used to display the vertical position of aircraft.
- The local barometric correction has been considered as being outside the surveillance system because it is performed by a user application (ATM).

# Data item needed for sep.

- **Identity.**
- This data item is obtained by either using the aircraft ID extracted from the aircraft or from its SSR Mode A reply.
- The identity is used to ensure that ATC instructions are passed to the correct aircraft. The identity extracted from the aircraft by the surveillance system is typically correlated with the flight plan data by the user application.
- However, this correlation function is considered to be outside the scope of the surveillance system definition.

# UPDATE RATE/UPDATE PERIOD

- The term “update rate” is usually used both for the output of the sensor and for the update of the display.
- In the context of performance, the latter is used with the assumption that the output of the surveillance system is fed directly into the display.
- Update period depends on local constraints such as type of traffic, maximum climbing rate of aircraft, type of airspace structure, legacy systems and Human Factor considerations.

## ICAO Doc. 4444 - 8.7.3 Separation minima based on ATS surveillance systems

- 8.7.3.1 Unless otherwise prescribed in accordance with 8.7.3.2, 8.7.3.3 or 8.7.3.4, or Chapter 6 (with respect to independent and dependent parallel approaches), the horizontal separation minimum based on radar and/or ADS-B and/or MLAT systems shall be 9.3 km (5.0 NM).

# IDENTIFICATION

- **8.6.2.2 ADS-B IDENTIFICATION PROCEDURES**
- Where ADS-B is used for identification, aircraft may be identified by one or more of the following procedures:
  - a) direct recognition of the aircraft identification in an ADS-B label;
  - b) transfer of ADS-B identification (see 8.6.3); and
  - c) observation of compliance with an instruction to **TRANSMIT ADS-B IDENT.**

# Requirements for ADS-B out Equipage

AIRBORNE

# PUBLICATIONS

<p>PHONE : 592-261-2269 FAX : 592-261-2279 AFTN : SYCJYOYX E-mail : AIS@gcaa-gy.org</p>	 <p>AERONAUTICAL INFORMATION SERVICE Control Tower Complex, Timehri EAST BANK DEMERARA GUYANA</p>	<p><b>AIC</b> A 05/14  (WHITE 41)  26 JULY 2014</p>
<p><b><u>Introduction of Aeronautical Surveillance Service within Georgetown Flight Information Region</u></b></p>		

[www.faa.gov/regulations\\_policies/advisory\\_circulars/](http://www.faa.gov/regulations_policies/advisory_circulars/)

# PUBLICATIONS

PHONE : 592-261-2269  
FAX : 592-261-2279  
AFTN : SYCJYOYX  
E-mail : AIS@gcaa-gy.org



**AERONAUTICAL INFORMATION  
SERVICE**  
Control Tower Complex, Timehri  
EAST BANK DEMERARA  
GUYANA

**AIP**  
SUPPLEMENT  
02/15  
07<sup>TH</sup> JUNE , 2015

**Commencement of Operational Trials for Aeronautical Surveillance Service  
using Automatic Dependent Surveillance Broadcast (ADS-B) out Operations  
within Georgetown Flight Information Region (SYGC UIR).**

# AIRBORNE EQUIPMENT



2.1.1 Operational Trials shall commence from **15 June 2015 until 11 November 2015**. During this period **from 03:00 to 11:00 UTC**, Georgetown Area Control Centre will be providing Surveillance service under the supervision of an Area Control Surveillance Instructor to accomplish the certification and Licensing of Air Traffic Controllers.

**2.1.2 With effect from 12th November 2015 the carriage of ADS-B equipage in compliance with para. 3.1, 3.2 or 3.3** will be required by all aircraft intending to operate within the Georgetown FIR (SYGC) at or above FL245.

2.1.3 Aircraft intending to operate within Georgetown FIR at or above FL245 with ADS-B equipage that are not in compliance with paragraph 3.1, 3.2 or 3.3, the ADS-B equipage shall be:

(a) deactivated; or

(b) set to transmit only a value of zero for the Navigation Uncertainty Category (NUCp) or Navigation Integrity Category (NIC).

### **3. Requirements for ADS-B out Equipage**

3.1 ADS-B equipage complies with 'RTCA DO-260 Minimum Operational Performance Standards', which is equivalent to ES Version 0 as specified in ICAO Annex 10, Volume IV, Chapter 3, Paragraph 3.1.2.8.6 and Chapter 2 of ICAO Doc 987.

3.2 ADS-B equipage complies with 'RTCA DO-260A Minimum Operational Performance Standards', which is equivalent to ES Version 1 as specified in ICAO Annex 10, Volume IV, and Chapter 3, Paragraph 3.1.2.8.6 and Chapter 3 of ICAO Doc 9871.

3.3 ADS-B equipage complies with 'RTCA DO-260B Minimum Operational Performance Standards', which is equivalent to ES Version 2 as specified in Chapter 4 of ICAO Doc 9871.

NOTE: To harmonise the ADS-B equipage, ICAO Planning and Implementation Groups suggested in order to standardize the equipment requirements, the following are the acceptable means of compliance to paragraphs 3.1, 3.2 or 3.3

- (a) The ADS-B equipage that have been certificated as meeting EASA Acceptable Means of Compliance **AMC 20-24 “Certification Considerations for Enhanced ATS in Non-Radar Areas using ADS-B Surveillance (ADS-B-NRA) via 1090 MHz Extended Squitter”**, or
- (b) The ADS-B equipage that meet the equipment configuration standards of **Australian Civil Aviation Order 20.18** Appendix XI, or
- (c) The ADS-B equipage that have been certified as meeting FAA Advisory Circular (**FAA AC) 20-165 or later changes.**



\$\$\$\$\$\$\$\$

- - GNS 430/530 Upgrade to WAAS -  
**\$3,395 US**
  - GTX 330 Mode-S ES Transponder -  
**\$4,796 US**
  - =**\$8,191 US** – approx.

GNS 430/530 Upgrade to WAAS -  
\$3,395

- GTX 23 Mode-S ES Remote  
Transponder - \$2,199

# QUESTIONS

