



# DIRECCIÓN GENERAL DE AERONÁUTICA CIVIL

## BOLIVIA

### *ENSAYOS / INSPECCIONES EN VUELO RNAV / RNP*

LIMA, AGOSTO 2016

# *Objetivo*



Dar a conocer a la comunidad aeronáutica internacional, las actividades de la Unidad de Ensayos en Vuelo del Estado Plurinacional de Bolivia.



# Contenido



- Generalidades y Definiciones
- Datos Sobre Aeronave
- Características de la consola de inspección en vuelo
- Validación de procedimientos RNAV
- Personal de operación



# *Generalidades*



- DGAC con Aeronave desde 2011
  - Beechcraft King Air B350
- Consola de Verificación Noruega-Alemana
  - NM3625B (NORMARC – AERODATA)
  - Sistema automatizado de Inspección en vuelo



# Definiciones



- **Ensayo.**- Una medición o verificación específica de la actuación de una instalación que puede formar parte de una inspección cuando esté integrada a otros ensayos.
- **Inspección.**- Una serie de ensayos realizados por la autoridad de un Estado o por una organización autorizada por el estado, para establecer la clasificación de la instalación en relación con las operaciones.

DOC 8071 OACI

# Definiciones



- **Pruebas de emplazamiento:** Ensayos en vuelo realizados al arbitrio de la autoridad responsable, para determinar los efectos del entorno del emplazamiento propuesto en la actuación de la radioayuda para la navegación prevista.
- **Puesta en servicio:** Una inspección exhaustiva en vuelo después de la inspección para prueba de la actuación en tierra, a fin de establecer la validez de las señales en el espacio. Los resultados de esta inspección deberían ser correlacionados con los resultados de la inspección en tierra. En conjunto constituyen las bases para la homologación de la instalación.
- **Inspecciones periódicas:** Inspecciones en vuelo para confirmar la validez de las señales en el espacio de forma regular o después de un importante mantenimiento programado.
- **Inspecciones especiales:** Inspecciones en vuelo necesarias por sospechas de mal funcionamiento, accidentes de aeronave, etc. Ordinariamente, es necesario someter a ensayos solamente aquellos parámetros que tienen, o pudieran tener, un efecto en la actuación de la instalación. Sin embargo, puede ser económicamente ventajoso en muchos casos completar los requisitos de una inspección periódica.

# Definiciones



- **Utilizable:** Disponible para uso en las operaciones.
  - **Sin restricciones:** Si proporciona señales en el espacio seguras y precisas conformes a las normas establecidas dentro del área de cobertura de la instalación;
  - **Limitada o restringida:** Si proporciona señales en el espacio que no se conforman a las normas establecidas en todos los aspectos y en todos los sectores del área de cobertura, pero utilizable con seguridad con determinadas restricciones. La instalación que pudiera estar en condiciones inseguras no debería ser clasificada como de uso limitado o restringido en ningún caso.
- **inutilizable:** No disponible para el uso en las operaciones por proporcionar señales inseguras o erróneas (posiblemente), o señales de calidad desconocida.

DOC 8071 OACI

# Infraestructura de radioayudas



EQUIPO RADIO AYUDA	CANTIDAD	PROYECTO	OBSERVACIONES
ILS/DME	3	4	
CVOR/DME DVOR/DME	2 8	2	Renovación CVOR/DME "PAZ" (DVOR/DME)
NDB	12	0	EN PROCESO DE DESACTIVACIÓN 36 NDB / 24 NDB
MSSR	1	6	

# *Datos de la aeronave*



- Beechcraft B300, King Air B350 FL304
  - Año de Fabricación: 2001
  - Matricula: CP-2600

*Con fase de mantenimiento 3 y 4 finalizadas*



# *Aeronave B300*

## *King Air B350*



# *Características de la Consola de verificación*

## NM3625B BOL CAPACIDADES

- ILS
  - LOC/GP Cat I, II y III (marker)
- CVOR, DVOR
- NDB
- DME
- SSR
- Procedimientos RNAV
- PAPI
- Comunicaciones VHF



# *Características de la Consola de verificación*

## CONSOLA DEL OPERADOR:

- Interface de usuario: Pantalla, teclado, Trackball, impresora en tiempo real, Panel de Audio, Osciloscopio.

Receptor MultiModo (*VOR, LLZ, GP, MKR, DME*) y un switch electrónico de Antena



# Características de la Consola de verificación

## Unidad Rack del equipo

- Generador de señales
- Amplificador de Audio
- ADF
- Receptor referencial de posición Global
  - 1 x GPS Trimble BD750
  - 1 x GPS NovAtel PROPAK G2 para RNAV
  - 1 x Telemetry Rx Monitron R45F(329,2MHz)
- Impresora a colores .

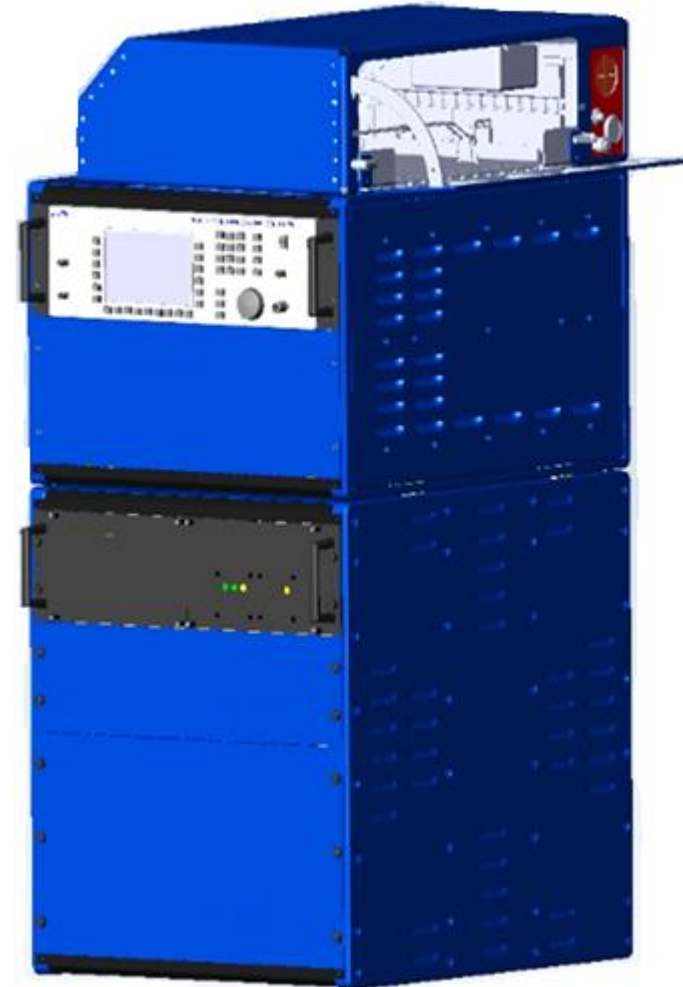

# *Características de la Consola de verificación*

## Sistema satelital de referencia:

- 1 x Estación Referencial en Tierra NM3680BOL



# Mini - GBAS

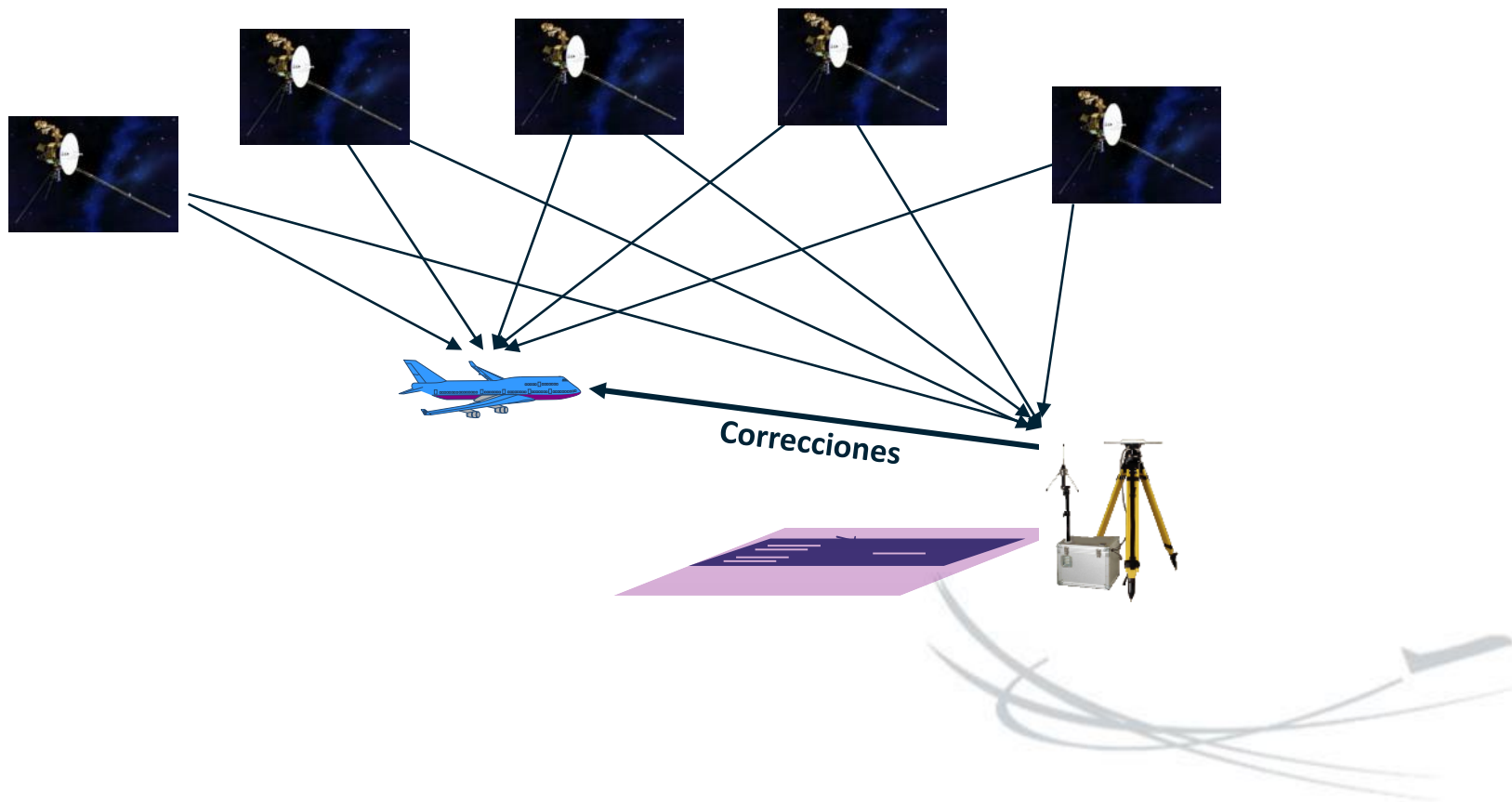

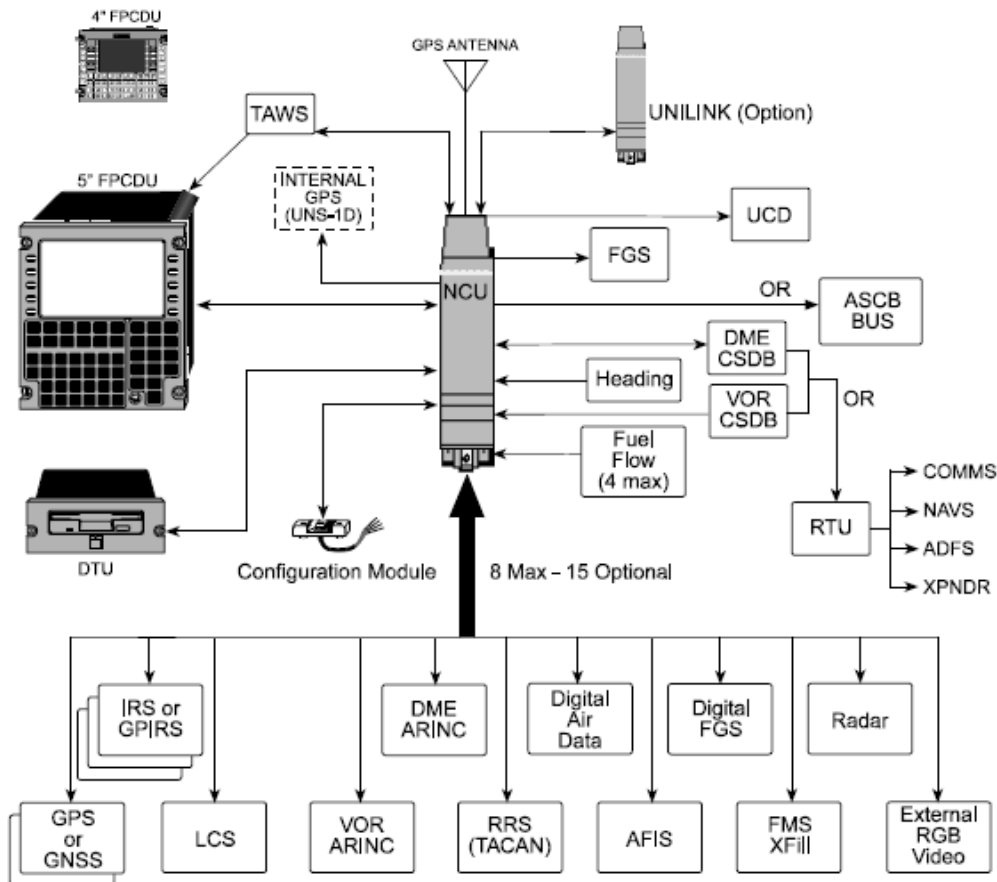

- Navigation System Management
- Pilot Data Storage
- Fuel Management Monitoring
- Lateral Guidance and Steering
- Vertical Guidance
- Navigation Database
- Flight Planning
- Frequency Management
- AFIS Advisory System Interface
- UniLink Interface



# *Sensibilidad de la FMS (GNSS)*



- Enroute display sensitivity +/- 5.0nm
- Terminal display sensitivity +/- 1.0nm
- Approach display sensitivity +/- 0.3nm



# *DVOR/DME "ALC"*



# *DVOR/DME "ALC"*





Options	FIP	Prec	Fac	Ref Src	TX no	Orb Ref	Alt Ref	Start Ang	Help
08:56:43 N		VOR ORBIT	ALC_VOR	GPS	2	6.0	3000.0	0.0	1.10.15

New Run	AZ(o)	VRAD(o)	NAGC (uV)	(empty)	REF MON
0	180	180	25	0	0
Prev/Next					
Calc	236	237	112	0	

Facility:	Alcantari VOR		Storage file:		1510.ALC_VOR.VO00766
Dist:	6.039	Compare: 0.063	PHI:	16.200	Ref Az(o): 236.353
Speed:	217.000	Ang rate: 10.000	AM (%):	29.272	Ref El(o): 4.648
Fac ID:	ALC	SC(Hz): 0.000	SC (%):	27.917	Alt(Ft): 3065.874
DME ID:	----	TTS: 1.600			Hdg(o): 155.300
Next Az	0.00000000	Orb Dir: ---	DME ERR	-0.015	T*** GVAL

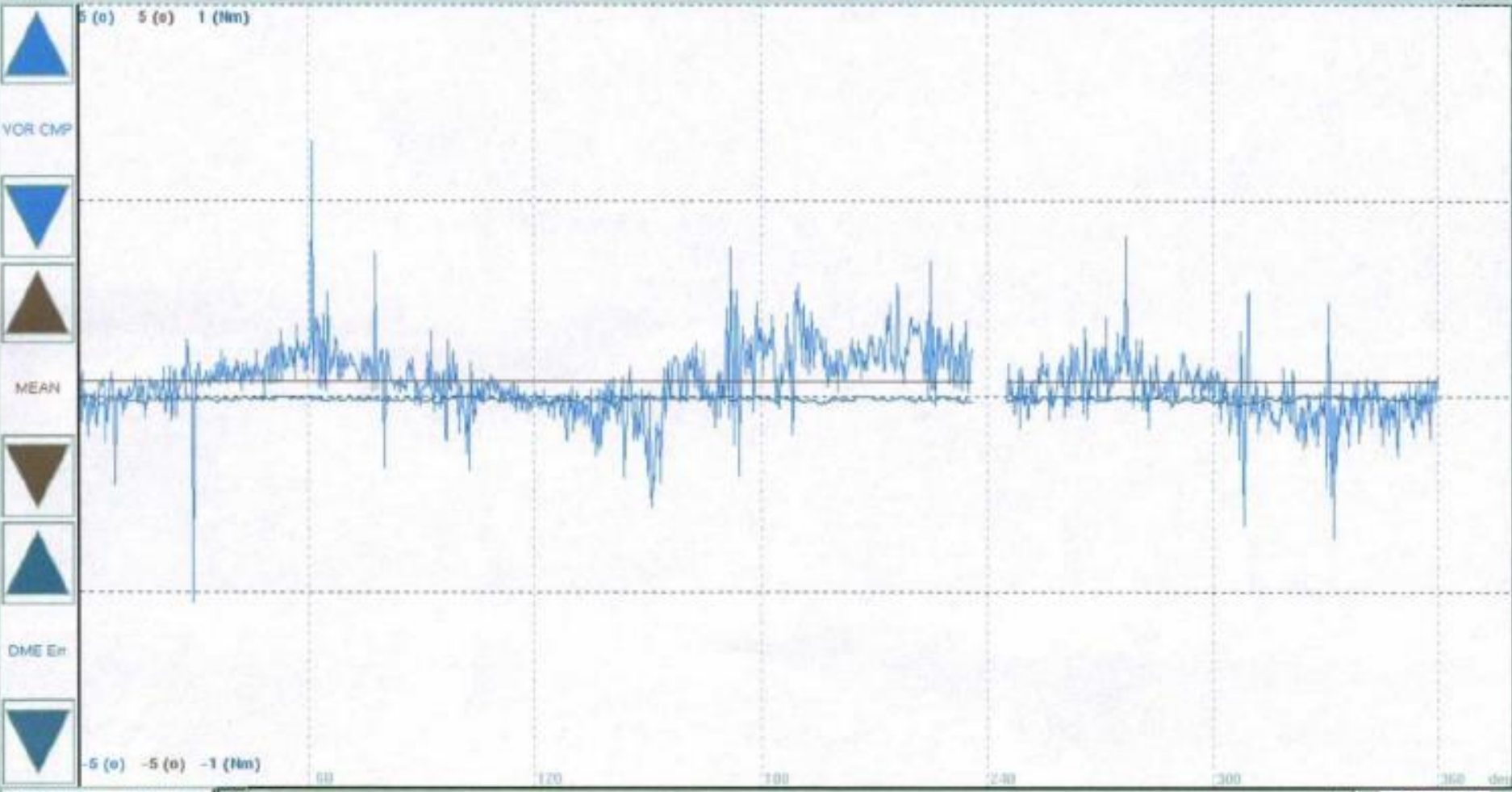

Options	FIP	Proc	Fac	Ref Src	TX no	Orb Ref	Alt Ref	Start Ang	Help
11:44:26 N		VOR ORBIT	ALC_VOR	GPS	2	10.0	8300.0	0.0	30.3.15
New Run		AZ(o)				VRAD(o)			MAGC (uV)
Prev Next	0	180	360	0		180	360	0	25
Calc		211				211			112

Facility:	Alcantari VOR		Storage file:	1509.ALC_VOR.V000755	
Dist:	10.239	Compare:	-0.223	FMI:	15.700
Speed:	244.000	Ang rate:	10.000	AM (°):	30.049
Fac ID:	ALC	SC(Hz):	0.000	BC (°):	31.250
DME ID:	----	TTS:	2.500	Alt(Ft):	8349.874
Next Az	0.00000000	Orb Dir:	---	DME ERR	-0.000
				T***	GVAL

REF MON  
AVION MON  
HW MON  
SW MON

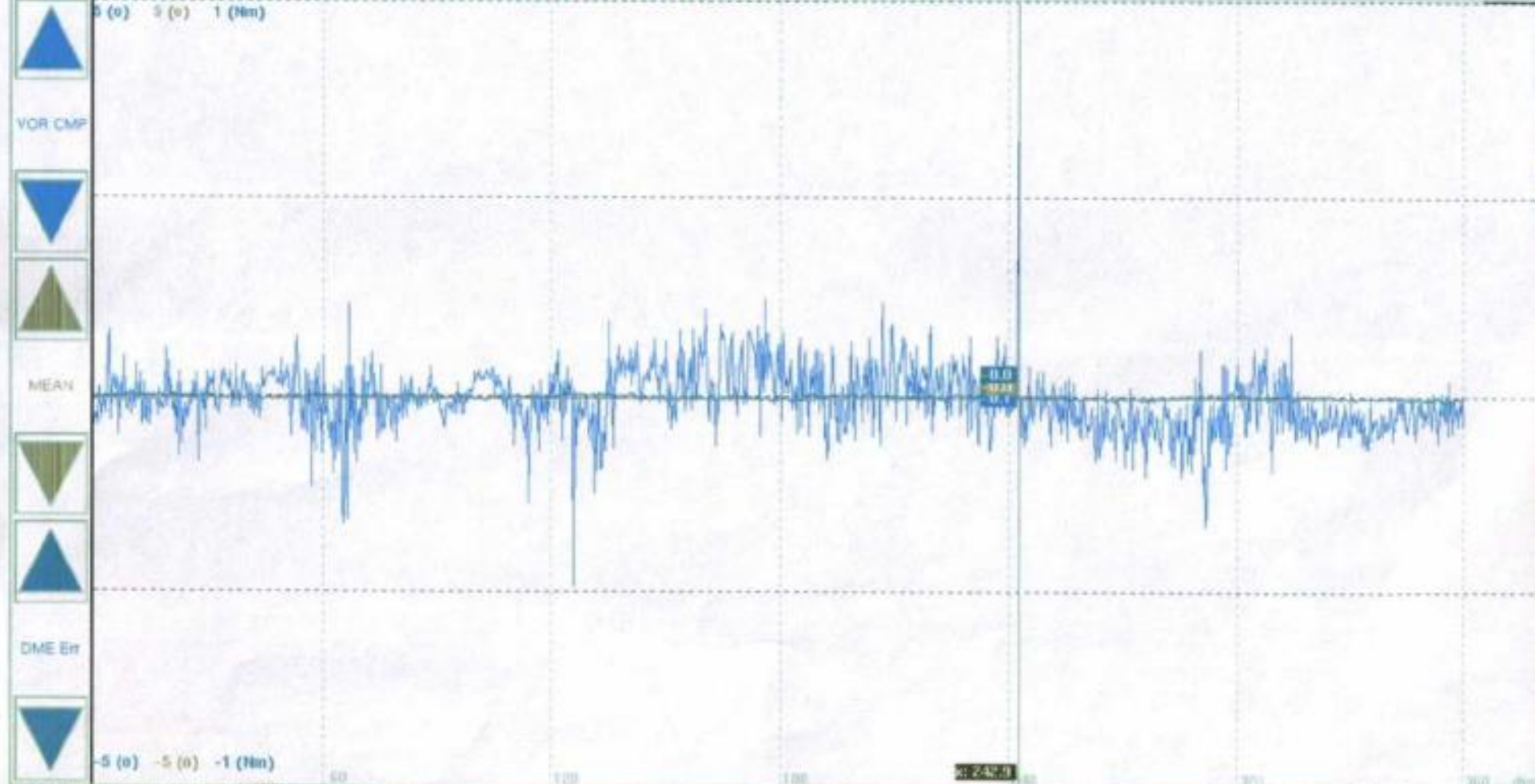

VOR ORBITS

	TX 1		TX 2		TOLERANCES	
	First	Final	First	Final	Min	Max
Run No. (#)	764.000	765.000	766.000	*****		
Error Spread (o)	*****					
CCW	0.759	*****	3.449	*****		
CW	2.725	*****	*****	*****		
Mean Value (o)						
CCW	0.268	*****	0.162	*****		
CW	0.218	*****	*****	*****		
AM Mod (%)	30.168	29.479	29.781	*****	28.000	32.000
SC Mod. (%)	30.496	29.088	29.762	*****	28.000	32.000
FM Index	16.224	16.211	16.338	*****		

	MAX	MEAN	MIN
0->10	-0.704	-0.161	-0.003
10->20	-1.699	-0.091	-0.002
20->30	-1.002	0.173	0.002
30->40	-1.560	0.390	-0.006
40->50	1.041	0.496	0.001
50->60	1.684	0.503	-0.003
60->70	1.039	0.367	0.000
70->80	0.944	0.294	-0.005
80->90	0.798	0.120	-0.002
90->100	1.423	0.141	-0.000
100->110	1.935	0.241	0.008
110->120	-1.866	0.261	-0.002
120->130	1.032	0.276	0.003
130->140	1.125	0.415	-0.001
140->150	1.612	0.490	0.003
150->160	1.182	0.673	-0.000
160->170	1.931	0.483	-0.004
170->180	2.360	0.705	0.003
180->190	2.346	0.872	-0.002
190->200	1.762	0.961	-0.001
200->210	1.396	0.927	0.017
210->220	1.983	0.000	-0.092
220->230	2.222	0.311	-0.002
230->240	-2.268	0.211	-0.008
240->250	1.009	0.215	0.000
250->260	1.567	0.202	-0.000
260->270	-0.866	-0.024	-0.000
270->280	-0.827	-0.182	0.000
280->290	-0.851	-0.363	-0.010
290->300	-1.151	-0.421	-0.016
300->310	-1.443	-0.389	-0.018
310->320	1.854	-0.177	-0.010
320->330	1.846	0.305	0.005
330->340	-1.366	-0.325	0.000
340->350	-0.717	-0.262	-0.005
350->360	-0.918	-0.280	-0.006





Options	ITP	Proc	Fac	Ref Src	TX no	Az Offset			Help
15:33:02 N		LLZ APP	VCZ_ILS	GPS	1	0.0			26.8.15

New Run	Az DEV(µA)	LDEV(µA)	MAGC(µV)	NAGC(µV)	REF MON
Prev Next	-50 0 50	-50 0 50	0 0 1600	0 50 100	
Calc	-712	-280	70	11206	

Facility:	Santa Cruz ILS	Storage file:	1508.VCZ_ILS.LA00705
Dist:	1.988	LCmp (µA):	-530.430
Year:	178.000	90Hz (†):	0.941
Fac ID:	VCZ	150Hz (†):	31.733
DHE ID:	VCZ	TTS:	0.600
		Ref Az(o):	-8.289
		Ref El(o):	1.030
		Alt (Ft):	197.334
		Hdg (o):	338.700
		T***	GVAL

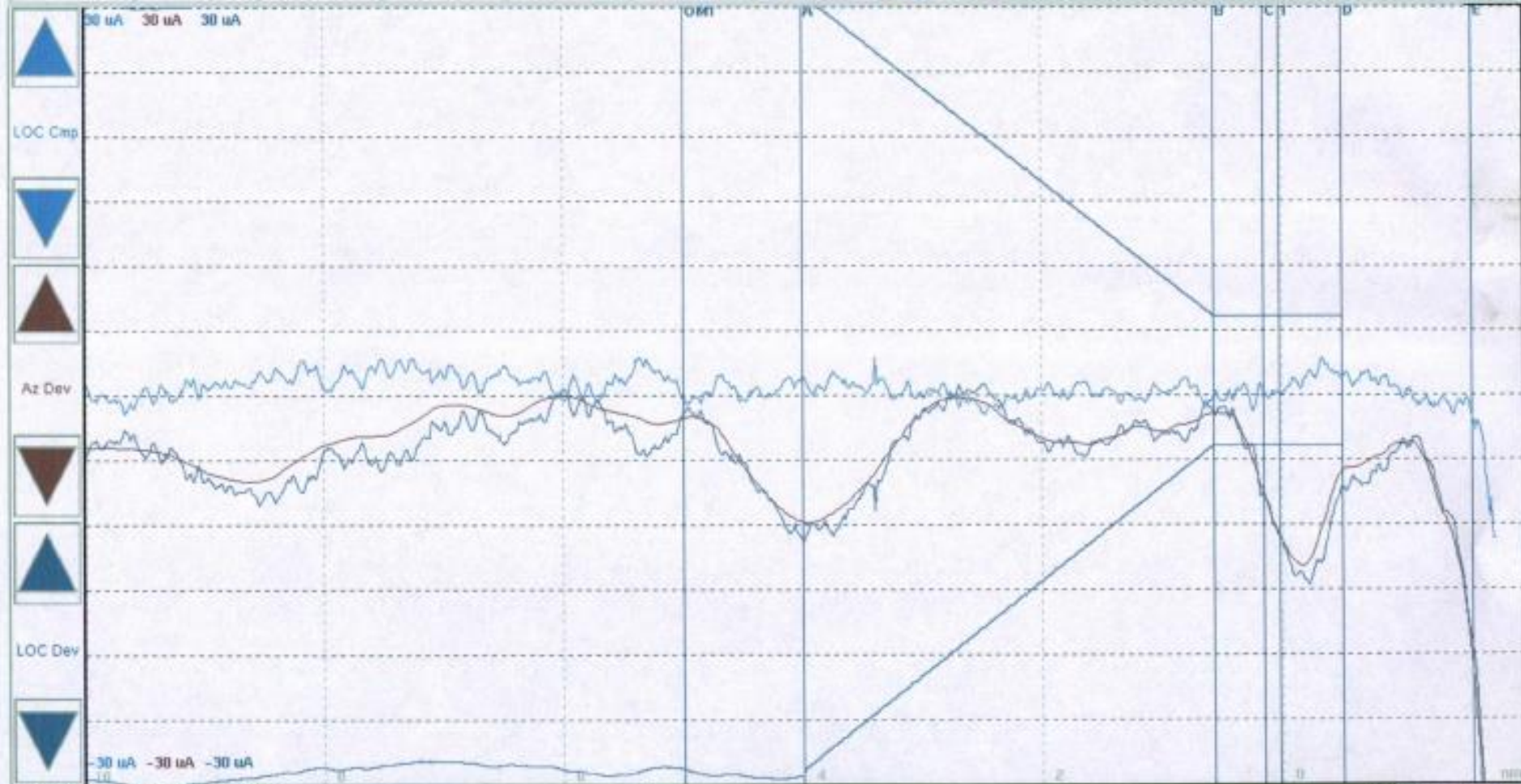

POSTRUN RVAL P\*\*\*  REF DIST

15:32:32 Storage file closed.  
15:27:24 System variables saved in flight dir.

***Validación en vuelo de  
Procedimientos de vuelo  
por instrumentos  
RNAV / RNP***



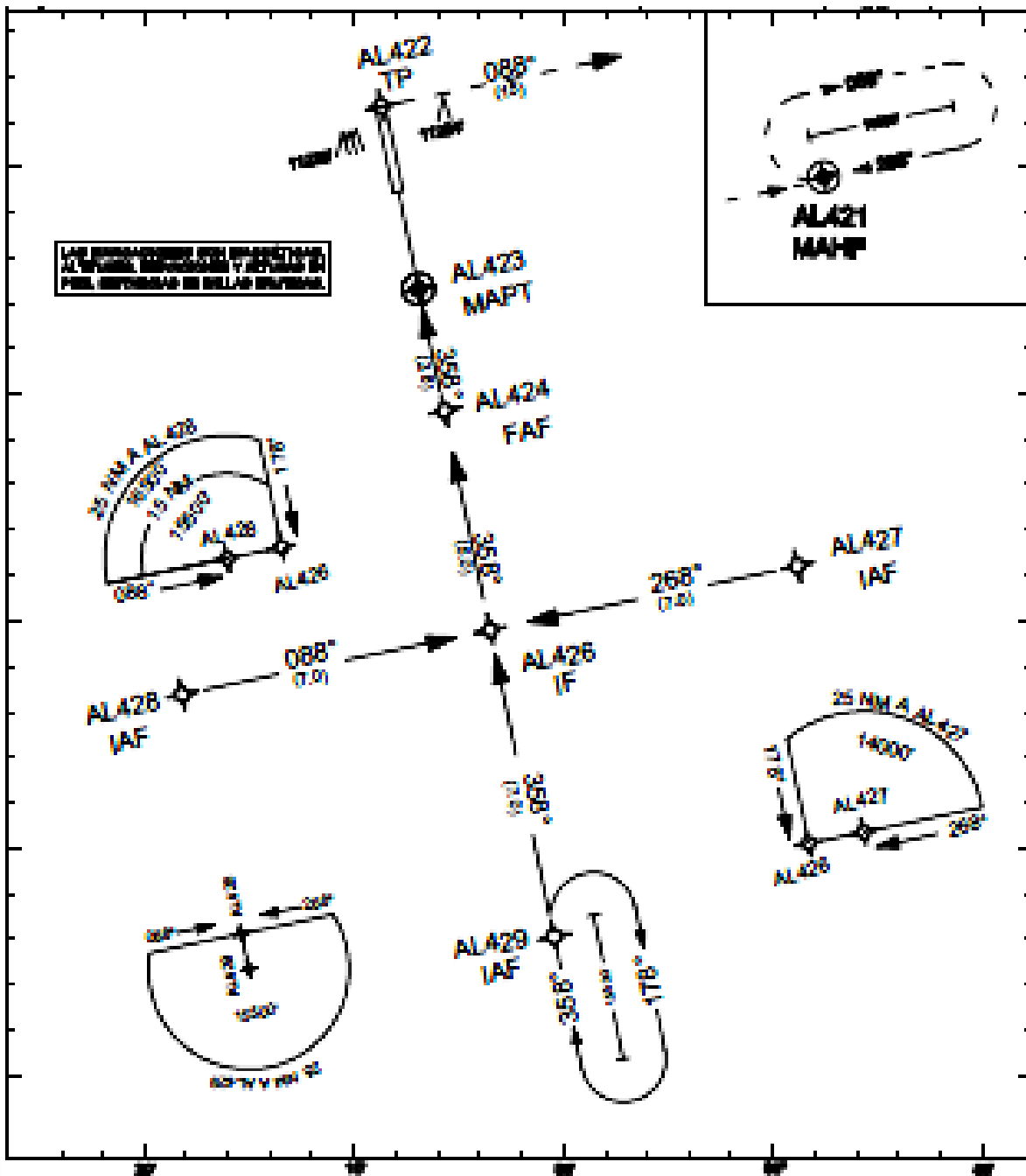

**CODIFICACION Y TIPOS DE TERMINACION DE TRAYECTORIA (PATH TERMINATOR)  
SLAL - RNAV GNSS Z RWY 36**

Num. De Serie	Descriptor de trayectoria	Identificador de punto de recorrido	Sobre vuelo	Curso °M(°T)	Variación Magnética	Distancia (NM)	Dirección de viraje	Altitud (FT)	Velocidad (KT)	VPA/TCH	Especificación de navegación
001	IF	AL429	-	-	-	-	-	+16000	-185	-	RNP APCH
002	TF	AL426	-	358° (348.9)	+9.5	7.0	-	-13700	-185	-	RNP APCH
001	IF	AL428	-	-	-	-	-	+16000	-185	-	RNP APCH
002	TF	AL426	-	088° (078.9)	+9.5	7.0	-	-13700	-185	-	RNP APCH
001	IF	AL427	-	-	-	-	-	+16000	-185	-	RNP APCH
002	TF	AL426	-	268° (258.6)	+9.5	7.0	-	+13700	-185	-	RNP APCH
001	IF	AL426	-	-	-	-	-	+13700	-185	-	RNP APCH
002	TF	AL424	-	358° (348.9)	+9.5	5.0	-	@11980	-	-	RNP APCH
003	TF	AL423	Y	358° (348.9)	+9.5	3.0	-	@10920	-	3.3/50	RNP APCH
004	TF	EGLAP	-	358° (348.9)	+9.5	26.2	-	+15000	-	-	RNP APCH
005	HM	EGLAP	-	178° (168.9)	+9.5	-	L	+15000	-	-	RNP APCH

**LISTA DE PUNTOS DE RECORRIDO (WAYPOINT)**

Identificador de punto de recorrido	Lat. Sur (seg)	Long. Oeste (seg)	Lat. Sur (min)	Long. Oeste (min)
AL429	19° 32' 01.95"	065° 05' 16.99"	19° 32.033'	065° 05.283'
AL428	19° 26' 29.21"	065° 13' 58.72"	19° 26.487'	065° 13.979'
AL427	19° 23' 45.23"	064° 59' 26.97"	19° 23.754'	064° 59.449'
AL426	19° 25' 08.24"	065° 06' 42.59"	19° 25.137'	065° 06.709'
AL424	19° 20' 12.73"	065° 07' 43.71"	19° 20.212'	065° 07.728'
AL423	19° 17' 15.37"	065° 08' 20.39"	19° 17.256'	065° 08.339'
EGLAP	18° 51' 26.74"	065° 13' 39.40"	18° 51.446'	065° 13.657'

# “Tipos de Terminación de Trayectoria” (ARINC 424)

<p>Heading to Radial</p> <p>VR</p>	<p>Course to Fix</p> <p>CF</p>	<p>Course from Fix to Altitude</p> <p>FA</p>	<p>Direct to Fix</p> <p>DF</p>
<p>Heading to DME Distance</p> <p>VD</p>	<p>Course to Altitude</p> <p>CA</p>	<p>Course from Fix to Along Track Distance</p> <p>FC</p>	<p>Procedure Turn</p> <p>PI</p>
<p>Heading to Intercept</p> <p>VI</p>	<p>Course to DME Distance</p> <p>CD</p>	<p>Course from Fix to DME Distance (Different Fix)</p> <p>FD</p>	<p>DME Arc</p> <p>AF</p>
<p>Heading to Manual Termination</p> <p>VM</p>	<p>Course to Intercept</p> <p>CI</p>	<p>Course from Fix to Manual Termination</p> <p>FM</p>	<p>Precision Arc to Fix</p> <p>RF</p>
<p>Heading to Altitude</p> <p>VA</p>	<p>Course to Radial</p> <p>CR</p>	<p>Initial Fix Track from Fix to New Fix</p> <p>IF TF</p>	<p>Holding Pattern to Fix, Altitude or Manual Termination</p> <p>HF HA HM</p>



Universal Flight Planning 25.6 (FMS SCN 801/901) WORLDWIDE 4000 FT - [Pilot Database - PILOT]

File Nav Database Satellites Options View Help

Routes **Waypoints** Airports Alignment Points Runways Approaches SIDs STARs

15 Waypoints (200 Max):

- AL421
- AL422
- AL423
- AL424**
- AL426
- AL427
- AL428
- AL429
- CH874
- CH875
- CH876
- CH877
- CH878
- CH879
- RW17

Waypoint: AL424  
 Lat: S 19° 20.212'  
 Lon: W 065° 7.728'

### LISTA DE PUNTOS DE RECORRIDO (WAYPOINT)

Identificador de punto de recorrido	Lat. Sur (seg)	Long. Oeste (seg)	Lat. Sur (min)	Long. Oeste (min)
AL429	19° 32' 01.95"	065° 05' 16.99"	19° 32.033'	065° 05.283'
AL428	19° 26' 29.21"	065° 13' 58.72"	19° 26.487'	065° 13.979'
AL427	19° 23' 45.23"	064° 59' 26.97"	19° 23.754'	064° 59.449'
AL426	19° 25' 08.24"	065° 06' 42.59"	19° 25.137'	065° 06.709'
<b>AL424</b>	<b>19° 20' 12.73"</b>	<b>065° 07' 43.71"</b>	<b>19° 20.212'</b>	<b>065° 07.728'</b>
AL423	19° 17' 15.37"	065° 08' 20.39"	19° 17.256'	065° 08.339'
EGLAP	18° 51' 26.74"	065° 13' 39.40"	18° 51.446'	065° 13.657'



Universal Flight Planning 25.6 (FMS SCN 801/901) WORLDWIDE 4000 FT

File Nav Database Satellites Options View Help

Pilot Database - PILOT

Routes Waypoints Airports Alignment Points Runways **Approaches** SIDs STARs

Airport	Approaches
SLAL	GWS 36
SLHI	

New... Delete Edit...

For Help, press F1

NavDB EXPIRED:02/04/16 Cycle: 1601 NUM

**Airport**

SLAL  
SLHI

**Approaches**

GWS 36

New...

Delete

Edit...

**Pilot Defined Approach**

Airport: SLAL    Approach Type: VDR    FAF: [ ] List At [ ] ft

Plain Name Search    Facility: VOR, VFR, RNAV, TACAN, ILS, LOC

Runway: 36    List    EDA: RW36    List At [ ] 10174 ft

Transition: N/A    FPA (FAF-EOA): [ ]    Previous Leg to EOA: InBnd Course [ ] \* Distance [ ] nm























Seg	Leg Type	Path	Ident	Latitude	Longitude	Alt Con	Altitude
C	EOA - Course to Fix	Crs 0.00°	RW36	S 19° 15' 285"	W 065° 8' 746"	At	10174

Insert    Edit    Delete    Done    Cancel

# “Tipos de Terminación de Trayectoria” (ARINC 424) (FMS)

Pilot Database - PILOT

### Leg Select

	Course To	Course From Fix To	Hold	Heading To	Arc
 Initial Fix IF	 Fix CF	 DME Distance FD	 At Fix HF	 Radial VR	 Const Radius Arc RF
 Track TF	 Radial CR	 Altitude FA	 At Altitude HA	 Altitude VA	 DME Arc AF
 Direct To DF	 Altitude CA	 Along Track Dist. FC	 Manual HM	 Intercept VI	
 Procedure Turn PI	 Intercept CI	 Manual FM		 DME Distance VD	
	 DME Distance CD			 Manual VM	

Cancel

Universal Flight Planning 25.6 (EMS SCN 801/901) WORLDWIDE 4000 FT

### Pilot Defined Approach

Airport:  Approach Type:  FAF:  List  11900 ft  
 Plain Name Search Facility:  List EOA:  List  10225 ft  
 Runway:  List Freq: n MHz FAF to EOA:  nm

Transition:

Seg	Leg T	Fix	Altitude	RNP	Course	Time	Fix	Lat	Long	Alt
T	Initial									
T	Track									
T	Track									
C	FAF - I	AL424	At 11900	0.30						
C	SD									
C	EOA - I									
M	Course to Fix	Crs 358.00°	AL423*	S 19° 17.472'	W 065° 8.294'					At/Above 10930
M	Course to Fix	Crs 358.00°	AL422	S 19° 13.373'	W 065° 9.142'					At/Above 11660
M	Hold at Fix	Crs 268.00° 1.0 min	AL421*	S 19° 10.462'	W 064° 53.592'					At/Above 15000
M	Course to Fix	Crs 88.00°	AL421	S 19° 10.462'	W 064° 53.592'					At/Above 15000

Buttons: Insert Edit Delete Done Cancel

### Leg Input

Fix:  List  Overfly Fix  
 Altitude:    
 RNP:

  
**Initial Fix** IF

Buttons: OK Cancel

Universal Flight Planning 25.6 (FMS SCN 801/901) WORLDWIDE 4000 FT - [Pilot Database - PILOT]

File Nav Database Satellites Options View Help

Routes Waypoints Airports Alignment Points Runways **Approaches** SIDs STARs

Airport

SLAL  
SLHI

Approaches

GWS 36

New... Delete

Edit...

**Pilot Defined Approach**

Airport: SLAL Approach Type: GWS FAF: AL424 List At: 11900 ft  
 Plain Name Search Facility: List EOA: RW36 List At: 10225 ft  
 Runway: 36 List Freq: n MHz  
 Transition: AL427 FPA (FAF-EOA): - 3.15 InBnd Course: 359.1 ° Distance: 5.0 nm

Seg	Leg Type	Path	Ident	Latitude	Longitude	Alt Con	Altitude
T	Initial		AL427	S 19° 23.753'	W 064° 59.450'	At/Above	15500
T	Track	268.80° 7.00 nm	AL426	S 19° 25.137'	W 065° 6.710'	At/Above	13400
T	Track	359.08° 5.00 nm	AL424	S 19° 20.212'	W 065° 7.728'	At/Above	11900
*GWS 36*							
C	FAF - Initial		AL424	S 19° 20.212'	W 065° 7.728'	At	11900
C	SD		+02.8	S 19° 17.454'	W 065° 8.297'	At/Above	10930
C	EOA - Course to Fix	Crs 358.89°	RW36	S 19° 15.285'	W 065° 8.746'	At	10225
*EOA*							
M	Course to Fix	Crs 358.00°	AL423*	S 19° 17.472'	W 065° 8.294'	At/Above	10930
M	Course to Fix	Crs 358.00°	AL422	S 19° 13.373'	W 065° 9.142'	At/Above	11660
M	Hold at Fix	Crs 268.00° 1.0 min	AL421*	S 19° 10.462'	W 064° 53.592'	At/Above	15000
M	Course to Fix	Crs 88.00°	AL421	S 19° 10.462'	W 064° 53.592'	At/Above	15000

Insert Edit Delete Done Cancel

For Help, press F1

NavDB EXPIRED:02/04/16 Cycle: 1601 NUM



2 Pilot Routes (200 Maximum)

Route ID	Origin	Destination
	SLLP	SLAL
LPZSCZ	SLLP	VIR

- New...
- Edit...
- Delete
- Copy...
- Predict GPS...
- Export Flight Plan
- Import Routes

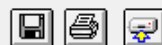

For Help, press F1



Route Edit

Route Name:

Identifier:

Selected Element Information:  
Missed Approach:

Flight Info:  
Fuel Flow: 600 pph  
Groundspeed: 250 knots  
Fuel Reserve: 600 lbs

Identifier	Course	Distance	Dist Rem	ETE	Fuel
SLLP			269.2 nm	00:00	1246
28.UREMA1					
Runway Tr...					
CRS 27...					
DIRECT...	278.99°	2.38 nm	266.9 nm	00:00	1240
<-CRS ...					
CRS 13...		24.99 nm	241.9 nm	00:06	1180
ESOMO					
UREMA	139.98°	30.00 nm	211.9 nm	00:13	1108
*NO LINK*					
DABLO	140.60°	140.14 nm	71.7 nm	00:47	772
GWS 36					
*NO LINK*					
Approach T...					
AL428	161.62°	54.08 nm	17.6 nm	01:00	642
AL426	74.54°	7.63 nm	10.0 nm	01:02	624
<-AL424	359.06°	5.00 nm	5.0 nm	01:03	612
AL424					
CRS 000.0°...		2.80 nm	2.2 nm	01:04	605
CRS 358.9°...		2.20 nm	0.0 nm	01:04	600
Missed App...					
CRS 35...					
CRS 35...					
-->AL421					
-->CRS ...					
*NO LINK*					
SLAL	02.30°	0.97 nm	1.0 nm	01:04	602



# DISPONIBILIDAD RAIM



SATDIS Servicio de Disponibilidad de Predicciones SAM RAIM

Jaime\_Alvarez | Grupo: Bolivia | Cerrar sesión

Inicio Herramientas Recursos Cuenta Administración Información Mapa del sitio

Estado Escenario de aeródromos Ruta Visibilidad

**Aeródromos**

Uno o más aeródromos

<< ant. 1 siguiente >>

OACI	IATA	Nombre	Elevación	Longitud	Latitud	Nivel de integridad
		ALCANTARÍ	10184 pies	-065 grados	-19 grados	RNP Approach

Receptor GPS

Nombre: Default GPS Receiver  
Receptor: C129 FD  
Ayuda baro: OFF  
Ángulo de enmascaramiento: 5°  
Predeterminado  
Nivel de integridad: RNP Approach

Configuración de hora

Inicio: 27-07-2016 14:49:21 UTC  
Duración: 24 horas

Predicción

Buscar

Aeródromos

OACI: SLAL  
IATA:  
Nombre: ALCANTARÍ  
Elevación: 10184 pies  
Latitud: -19 grados  
Longitud: -065 grados  
Propietario:  
Acción:  
Nivel de integridad: RNAV1  
ACEPTAR

Avanzado Añadir personalizada

Desarrollado por DWI | Exención de responsabilidades

Versión: 1.0.0-SNAPSHOT | Contacto



## Servicio de Disponibilidad de Predicciones SAM RAIM

[Saltar a contenido](#)  
[Español](#)

[Jaime\\_Alvarez](#) | [Grupo: Bolivia](#) | [Cerrar sesión](#)

Inicio	<b>Herramientas</b>	Recursos	Cuenta	Administración	Información	Mapa del sitio
Estado	<b>Escenario de aeródromos</b>	Ruta	Visibilidad			

**Aeródromos**

SLAL

---

**Receptor GPS**

Nombre: Default GPS Receiver  
Receptor: C129 FD  
Ayuda baro: OFF  
Ángulo de enmascaramiento: 5°  
Predeterminado  
Nivel de integridad: RNP Approach

---

**Configuración de hora**

Inicio: 27-07-2016 15:16:54 UTC  
Duración: 24 horas

---

**Predicción**

**Aeródromos**

<< ant. **1** siguiente >> | Elementos por página: **5**

OACI	IATA	Nombre	Elevación	Latitud	Longitud	Nivel de integridad	
SLAL		ALCANTARI	10.184pies	-19°	-85°	RNAV1	✘

**Buscar**

Aeródromos

## LISTA DE PUNTOS DE RECORRIDO (WAYPOINT)

Identificador de punto de recorrido	Lat. Sur (seg)	Long. Oeste (seg)	Lat. Sur (min)
AL429	19° 32' 01.95"	065° 05' 16.99"	19° 32.033'
AL428	19° 26' 29.21"	065° 13' 58.72"	19° 26.487'
AL427	19° 23' 45.23"	064° 59' 26.97"	19° 23.754'
AL426	19° 25' 08.24"	065° 06' 42.59"	19° 25.137'
AL424	19° 20' 12.73"	065° 07' 43.71"	19° 20.212'
AL423	19° 17' 15.37"	065° 08' 20.39"	19° 17.257'
EGLAP	18° 51' 26.74"	065° 13' 39.40"	18° 51.446'



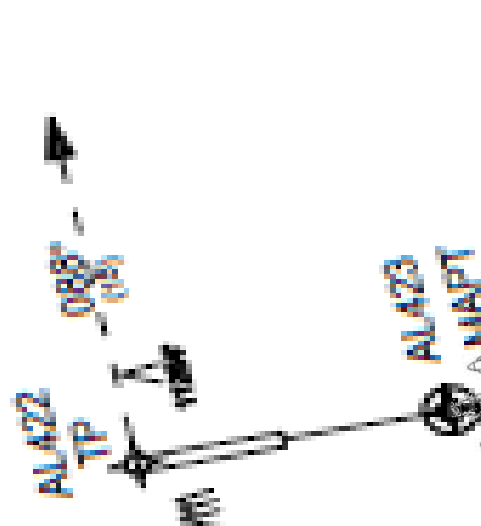
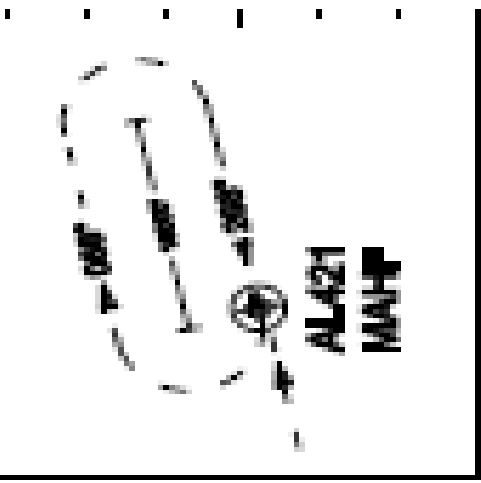

LAS MANIOBRAS SON REALIZADAS AL VUELO, SIN PREVIAS CONSULTAS NI PREVIAS ENTREVISTAS EN BILBAO IMPRONTA.

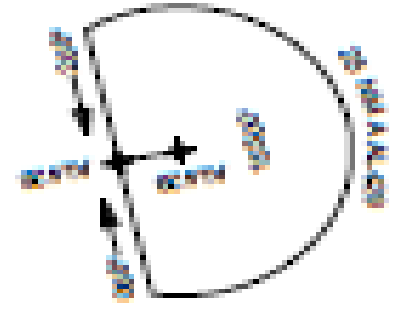
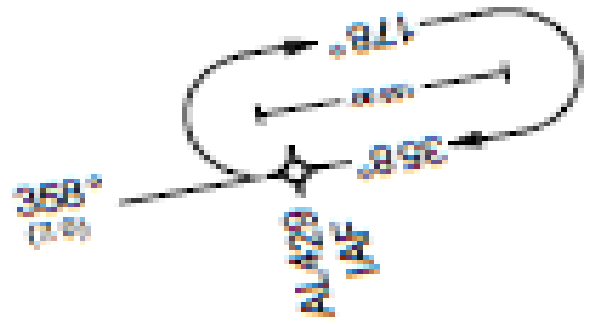
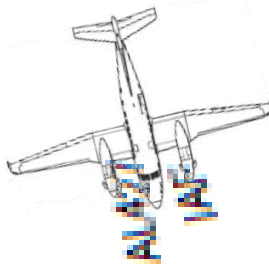
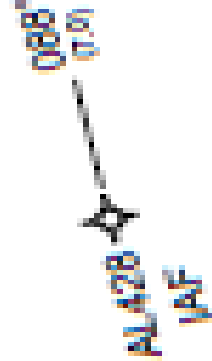
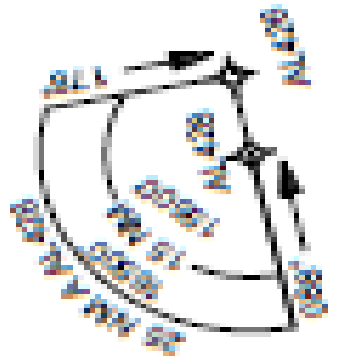
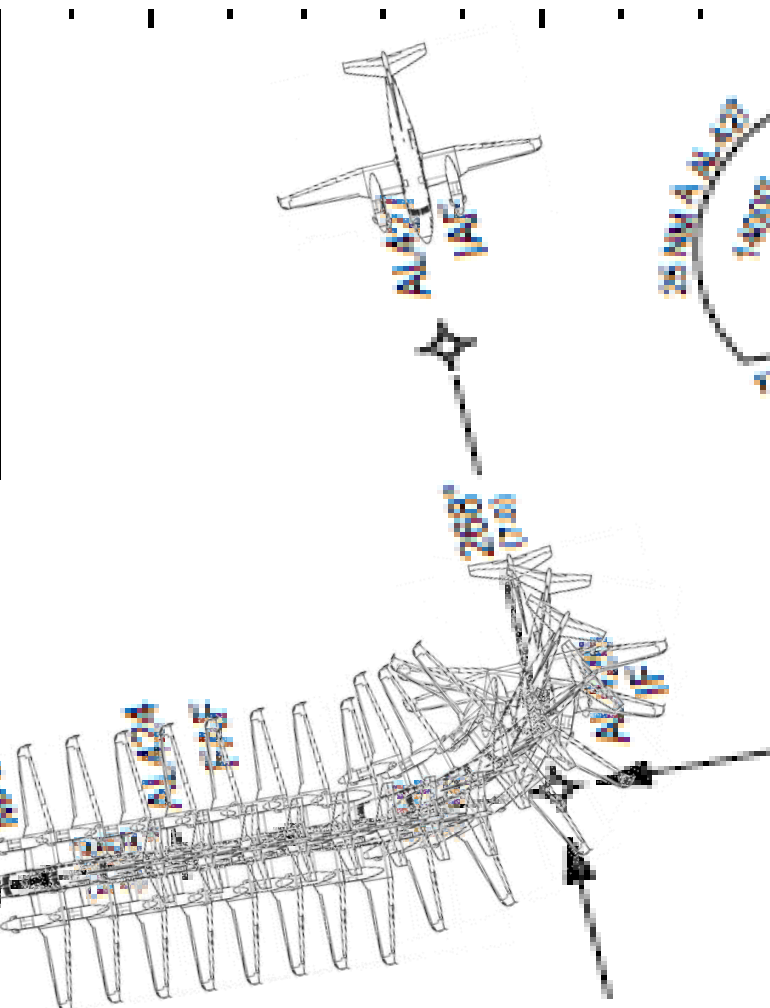



FORMULARIO PARA HOMOLOGACIÓN DE PROCEDIMIENTOS DE APROXIMACIÓN

Datos Generales

Aeropuerto <i>SLRP</i>	Identificación del procedimiento <i>2NDV GNAS 2ndy 14</i>	Fecha y hora <i>20/08/10 - 15:30 UTC</i>
Empresa <i>DGAC</i>	Tipo de aeronave <i>36250</i>	No de vuelo/Matricula <i>CP 2600</i>
Piloto al mando <i>Capitán Luis TRIGO</i>	Copiloto <i>Cap. Julio FERRER</i>	Inspector FANS-OPS DGAC <i>César VARELA</i>

Tipo de Procedimiento

Precisión  No de precisión  GNSS

Ayudas no visuales en que se basa el procedimiento

NDB  VOR  DME  VOR/DME  ILS

Condiciones Meteorológicas

VMC <input checked="" type="checkbox"/>	SKC <input type="checkbox"/>	FEW <input type="checkbox"/>	SCT <input checked="" type="checkbox"/>	BKN <input type="checkbox"/>	OVC <input type="checkbox"/>	QNH
---	------------------------------	------------------------------	---	------------------------------	------------------------------	-----

Nota: Toda homologación de procedimiento por publicarse, deberá realizarse en FMC.

Procedimiento de aproximación

TRAMO	AREA	MOC	PENDIENTE	MARCACION	OBSERVACIONES
Ruta de llegada	-				
Inicial	<i>1°</i>	<i>300M</i>	<i>2.65%</i>	<i>252.73°</i>	<i>JAT(2) 2ºPS1</i>
Intermedio	<i>1°</i>	<i>150M</i>	<i>5.2%</i>	<i>135.37°</i>	
Final	<i>1°</i>	<i>400'</i>	<i>6.2%</i>	<i>125.39°</i>	
Aproximación finalizada	<i>1°</i>	<i>30M</i>	<i>2.6%</i>	<i>112.72°</i>	

Observaciones Generales

*Sin observaciones; procedente para publicación*

*Capitán Luis TRIGO*  
Piloto al mando

*Capitán Julio FERRER*  
Copiloto

*César VARELA*  
Inspector FANS-OPS DGAC  
César A. Varela Carbajal  
JEFE UNIDAD PLANIFICACIÓN  
ESPACIOS AEROS  
Dirección General de Aeronáutica Civil

Form DGAC-DNA-FANS OPS/ 251/88



# Procedimientos RNAV

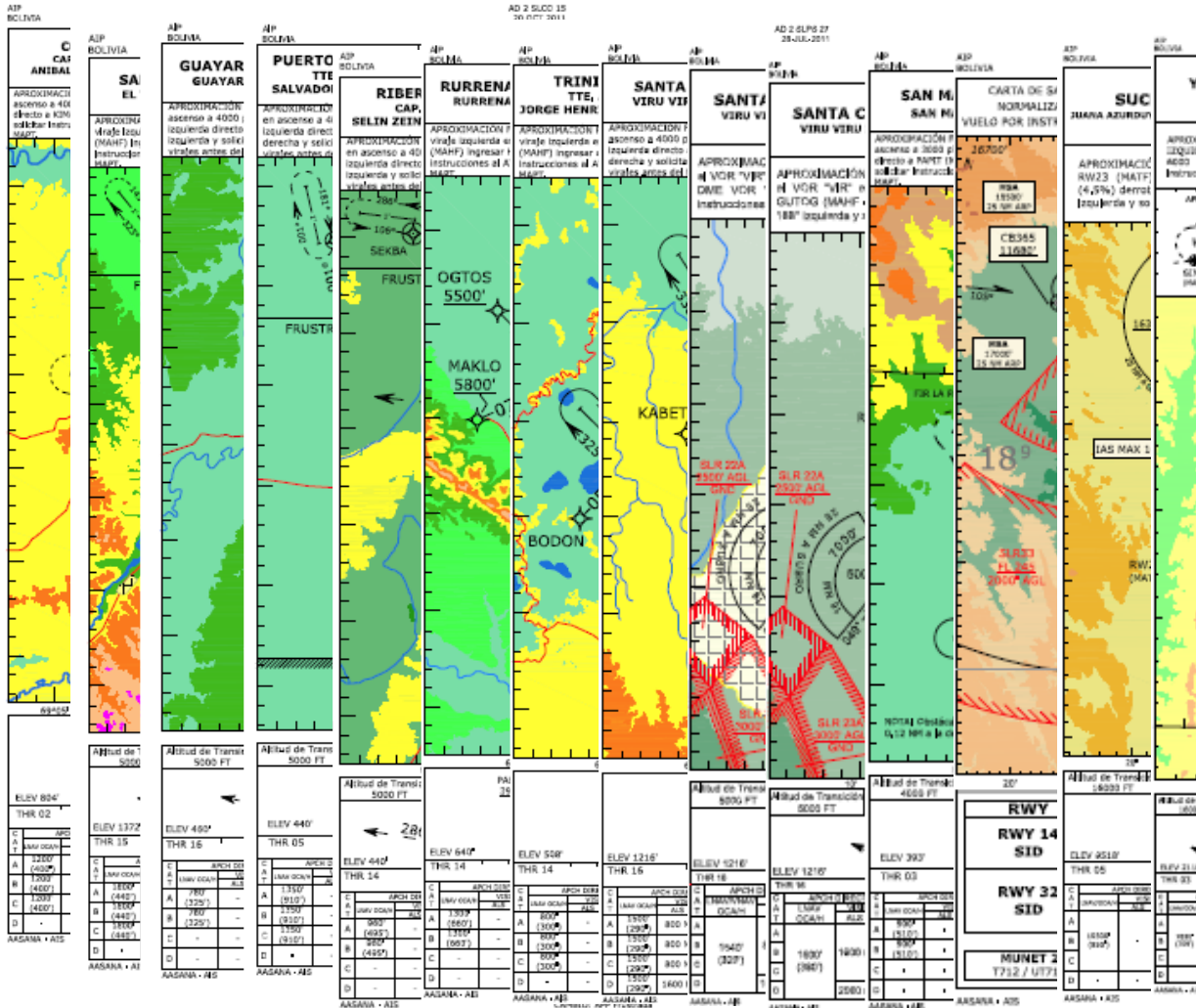

# Personal de Inspección en Vuelo DGAC



# Conclusiones



- El Estado Plurinacional de Bolivia cuenta con el equipo de trabajo para realizar inspecciones en vuelo de radioayudas
- Tomar nota del procedimiento y la capacidad de la aeronave y el equipo de trabajo del Estado Boliviano para las validaciones en vuelo RNAV.



**ATCO. César Augusto Varela Carvajal**  
**Director Ejecutivo a.i.**  
**Dirección General de Aeronáutica Civil**  
**Av. Arce 2136 Edif. Multicine Piso 9**  
**La Paz, Bolivia**

---

## **Dirección de Navegación Aérea**

*Ing. Jaime Yuri Alvarez Miranda*

*Jefe de la Unidad CNS*

*[Jalvarez@dgac.gob.bo](mailto:Jalvarez@dgac.gob.bo)*

*Cel.591 – 72043698*

*Tel. 591-2-2444450 int. 2651*

*Fax. 591-2-22114465*

***GRACIAS***

