

Thirteenth CAR/SAM Regional Bird/Wildlife Hazard Prevention Committee Meeting and Conference  
Décima tercera Reunión y Conferencia del Comité Regional CAR/SAM de Prevención del Peligro Aviario/Fauna  
(CARSAMPAF/13)

Ciudad de Panamá, 20 al 23 de octubre de 2015

SAFETY MANAGEMENT IN THE ENVIRONMENT AND FAUNA / GESTION DE LA SEGURIDAD OPERACIONAL DEL  
MEDIO AMBIENTE Y FAUNA

# Grass management at airports



# What kind of grass management ?

- Long grass management
- Short Grass management
- First 15 meter next to run-taxiway



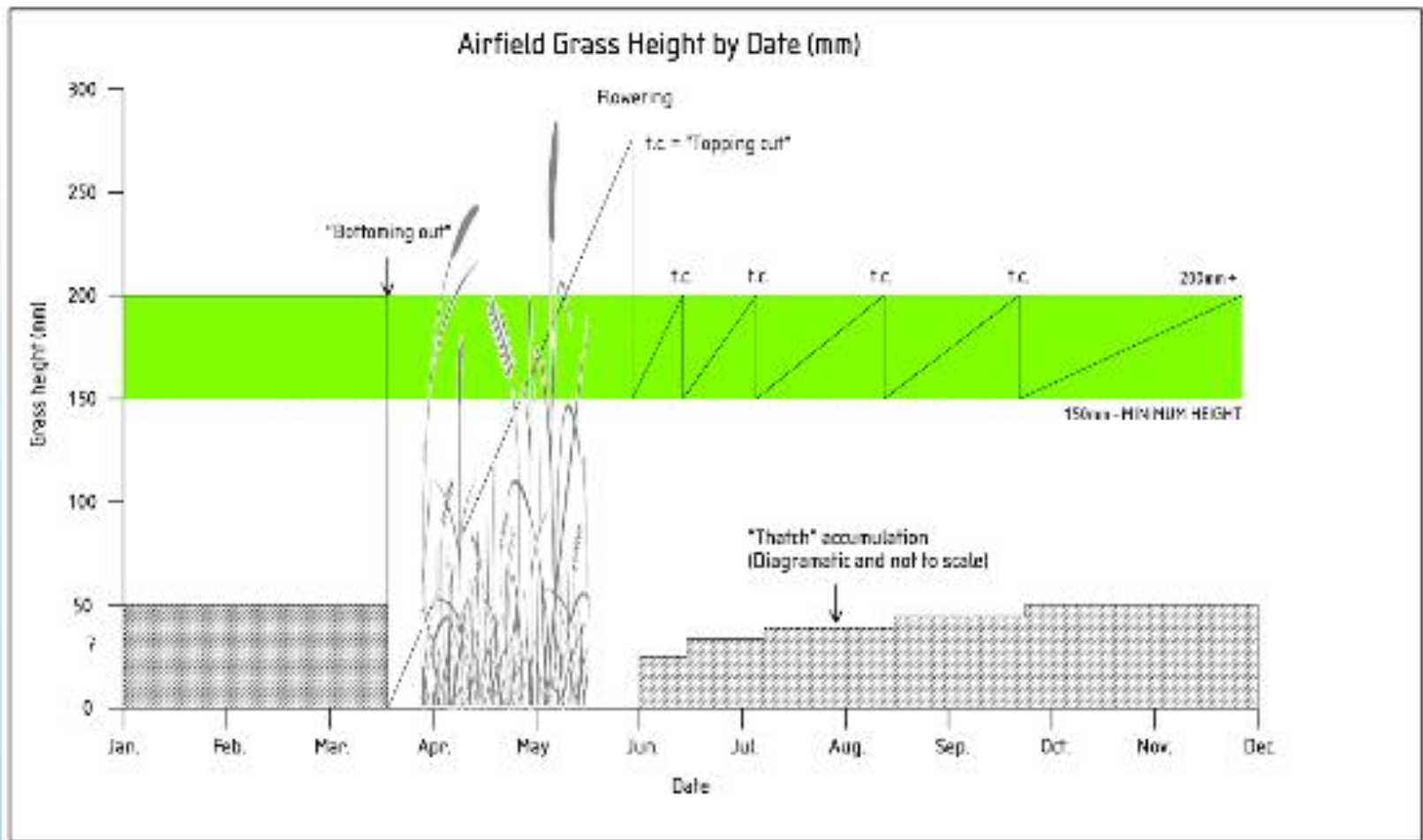

- Rat and mice etc. can hide from their predator
- When flowering, seedheads attracts small birds
- Hard for visual inspection
- Reduced operating costs ( Fuel and labour)
- Different presentation from the airport



Cutting grass with agricultural disc mower



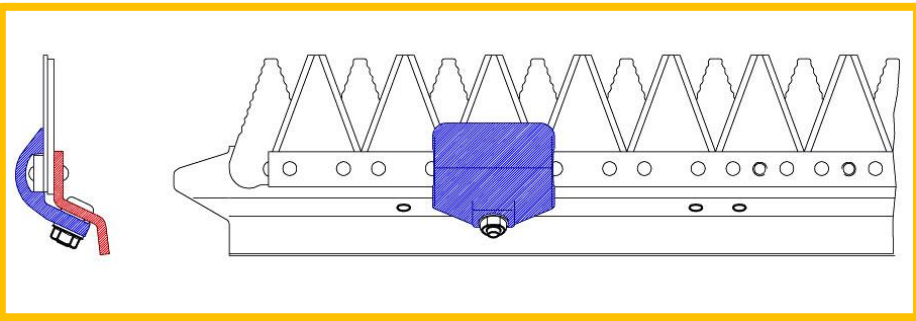

Cutting grass with agricultural sickle bar





Cutting & mulching grass with rotary mower



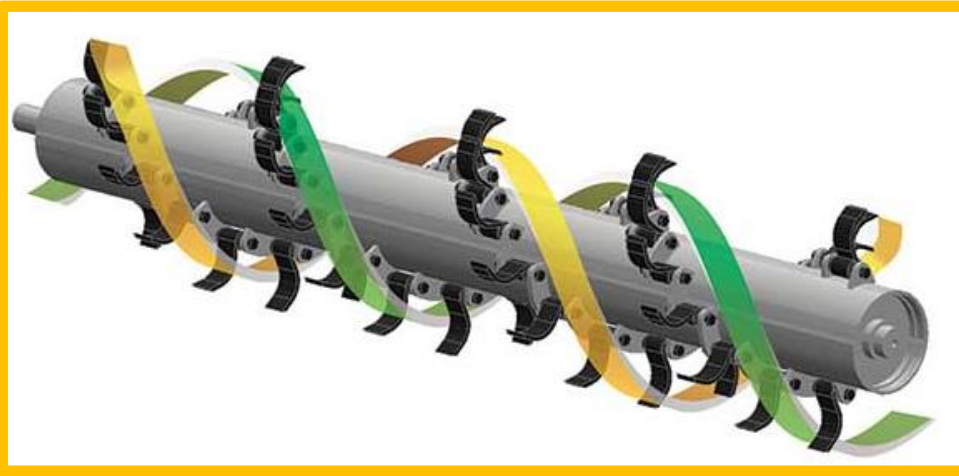

Cutting & mulching grass with flail mower





Old clippings attracts insects, rodents, snake, bird





Collecting grass-clippings to avoid that build up



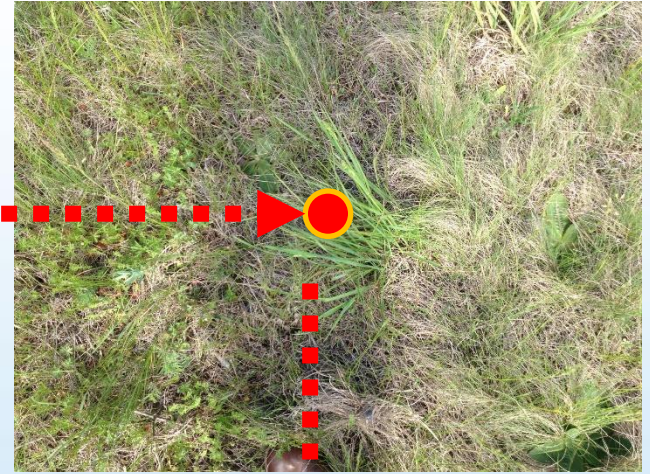
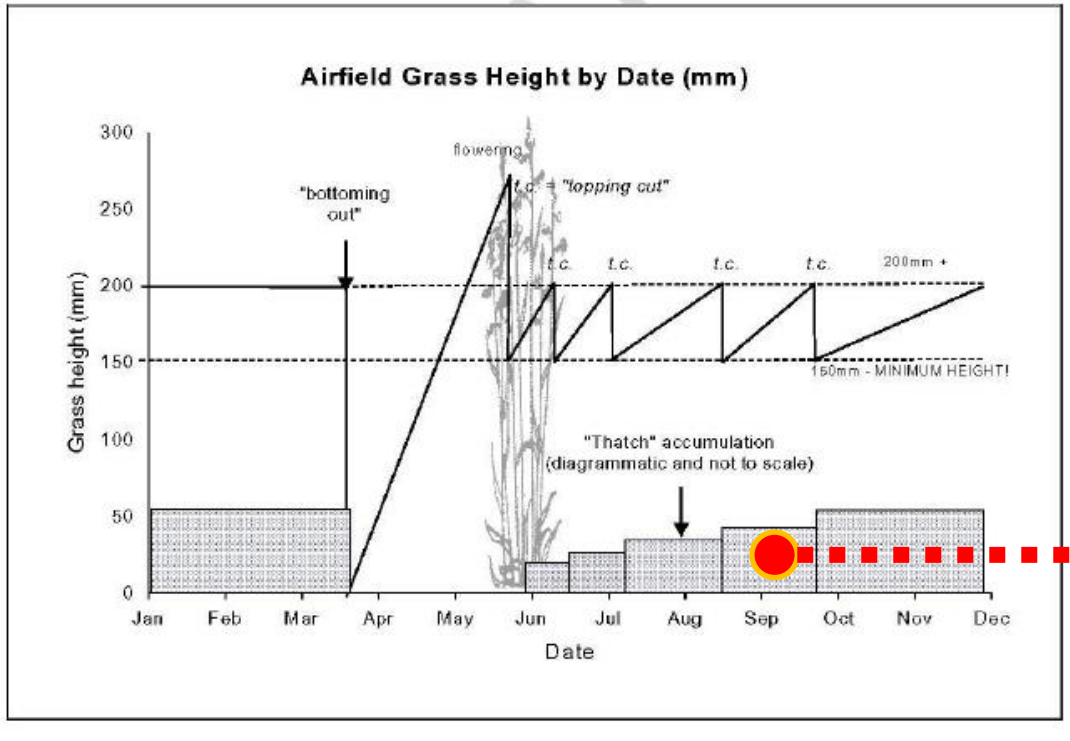

# Traditional Long Grass Policy (LGP)





Cutting grass at height of 20 cm / 8 inch





The system





How it works



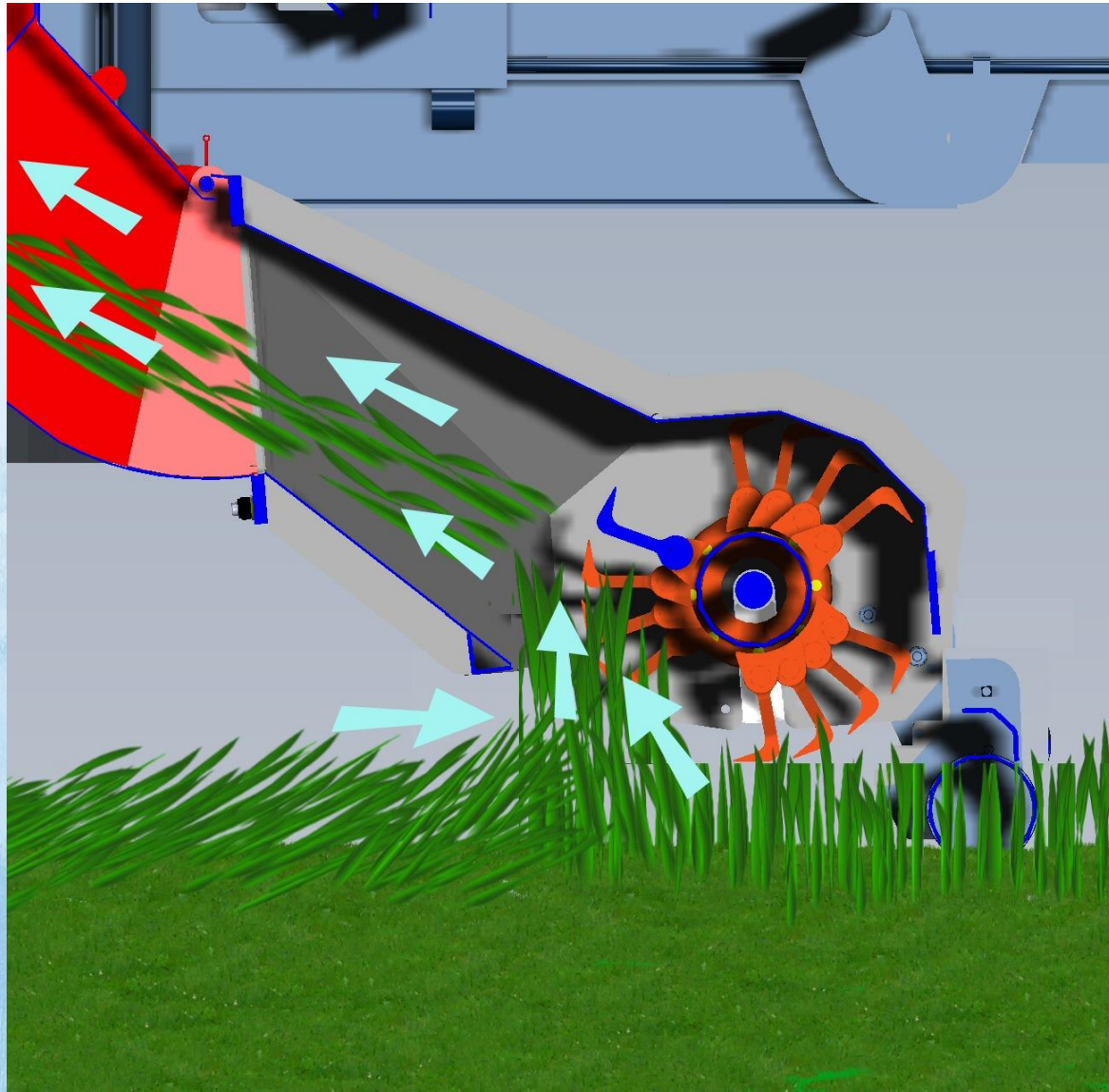

Cutting grass at 20 cm height



Cutted grass with agricultural mower





Cut and collect grass how it should be





Cut and collect in one single pass



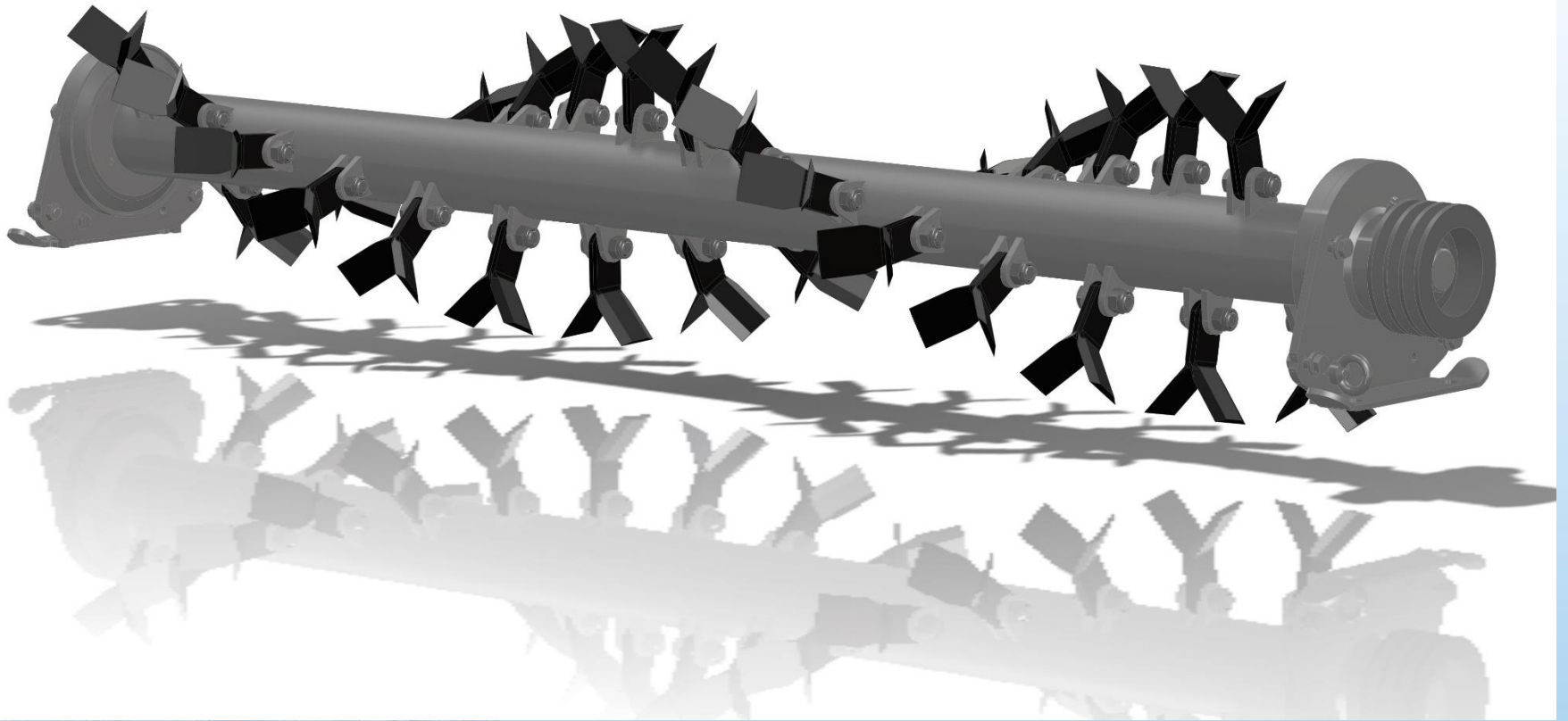

Heavy duty flailshaft with Y blades for wetlands



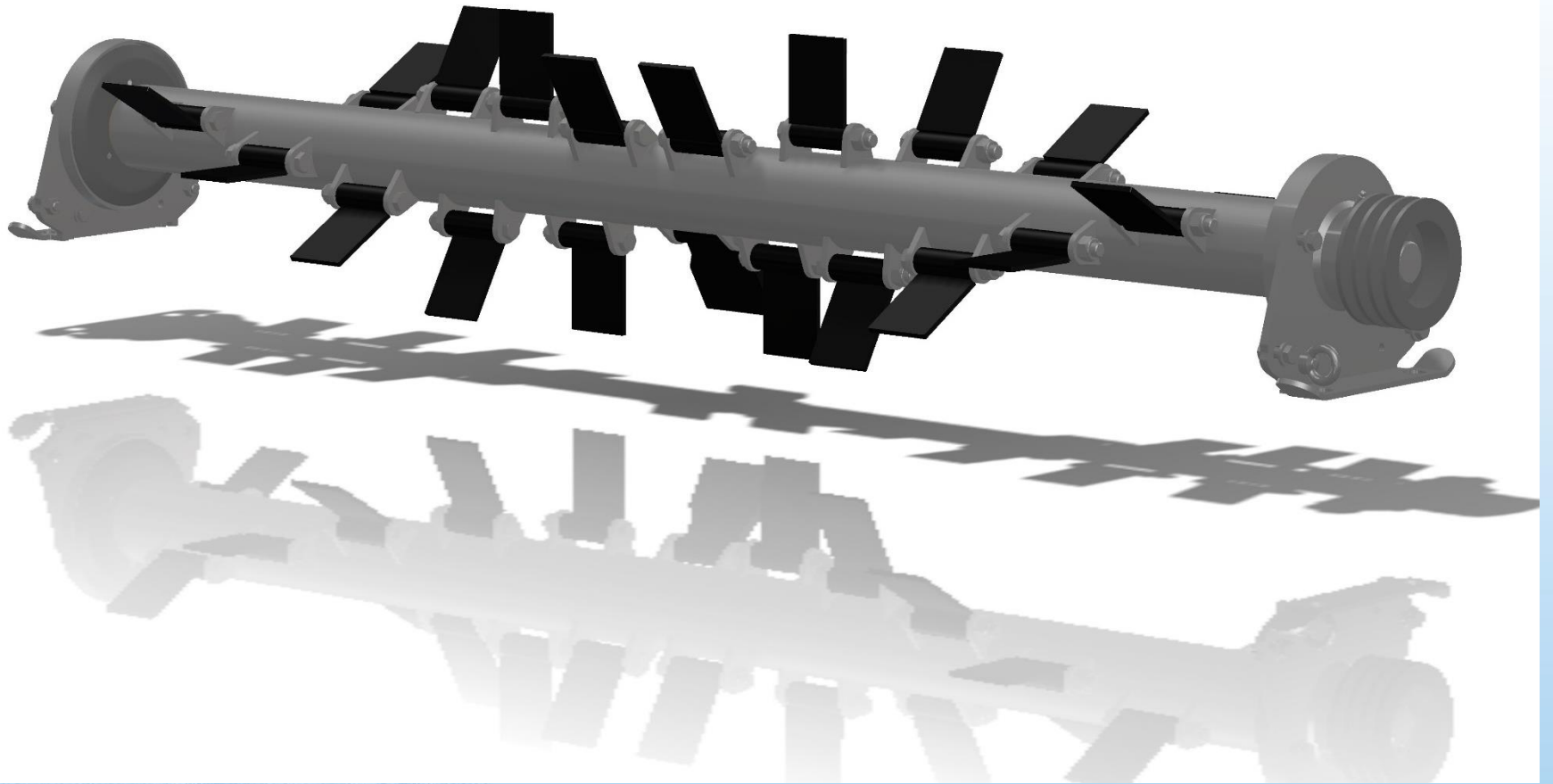

Heavy duty flailshaft for dry area's





Heavy duty flailshaft





Cut and collect





Collecting grass clippings and FOD





Collecting grass clippings and FOD





## Collecting FOD



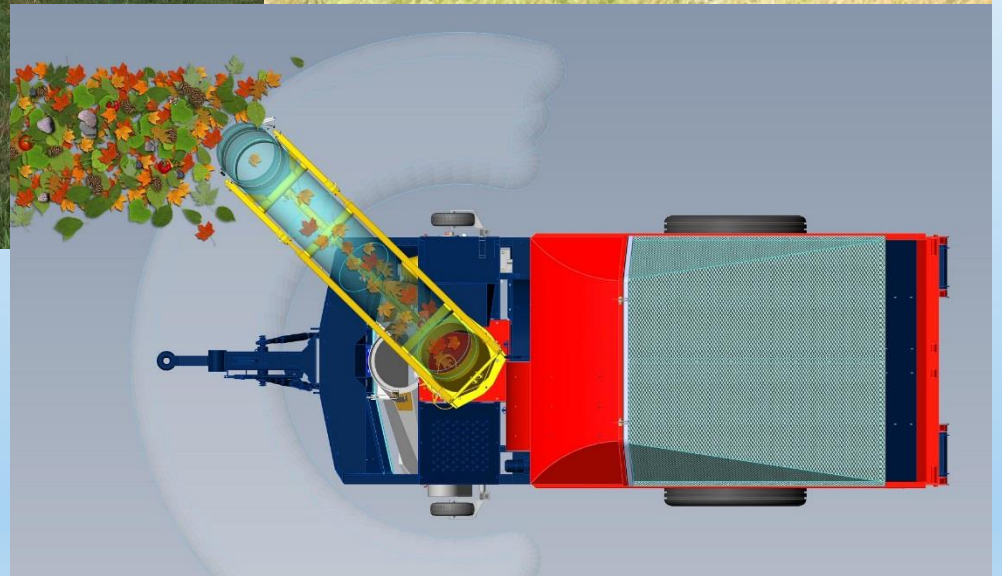

## Collecting FOD capability



Video Cut and collect grass and FOD in one pass





The result, 100 % clean grass with nice striping



# Short Grass management facts

- Cutting grass every 2 weeks
- Eliminating vegetation removes food source
- Easy for visual inspection
- Machines available with a high capacity up to 7 Ha/h ( 18 Acre/h)
- Very effective on helicopter bases ( military)
- Nice presentation of your grass area



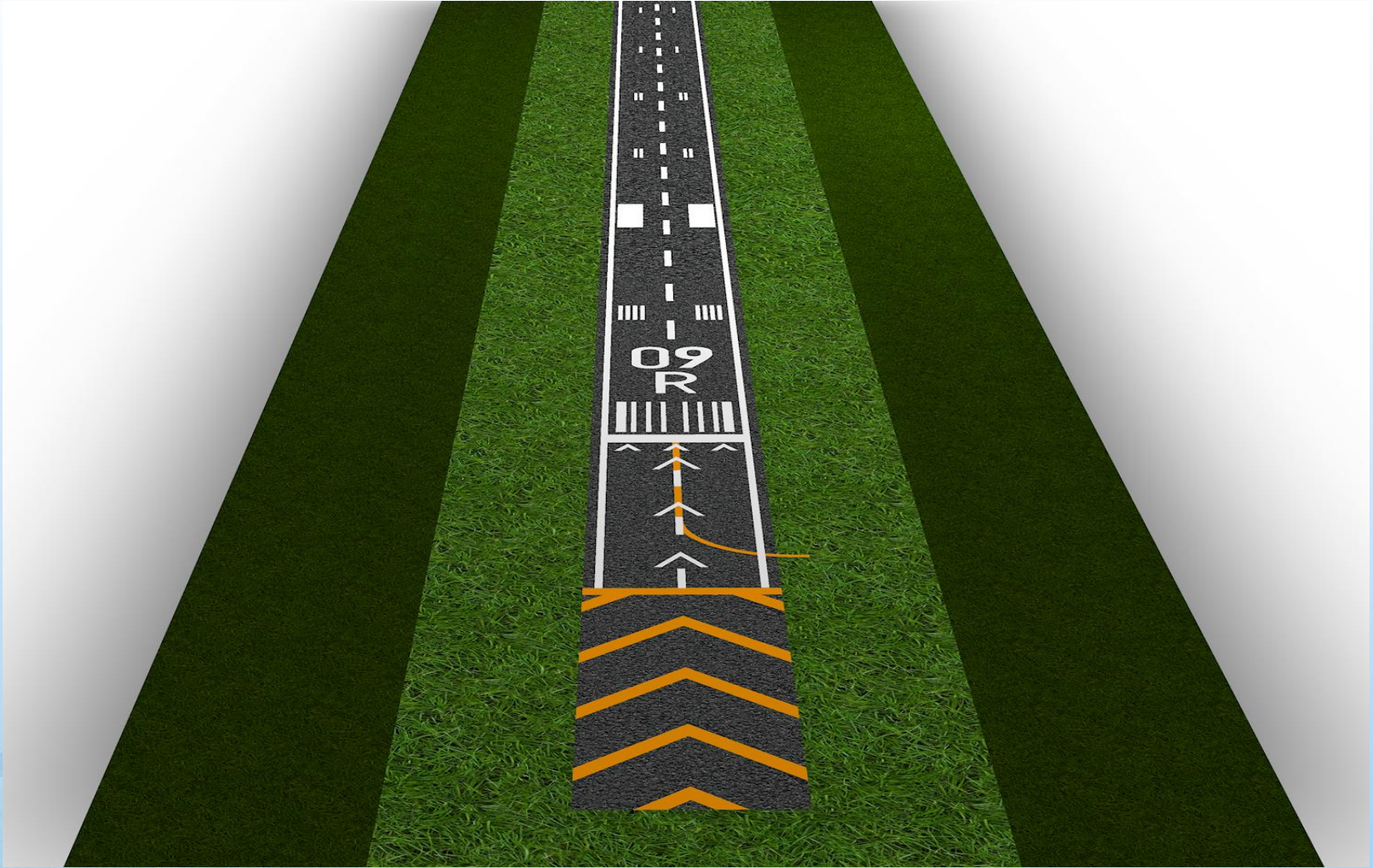

Cutting first 15-20 meter next to runway





## Cutting and wide area collection





Grass cutting and collecting at 10 cm





Cutting and collecting FOD in the same pass



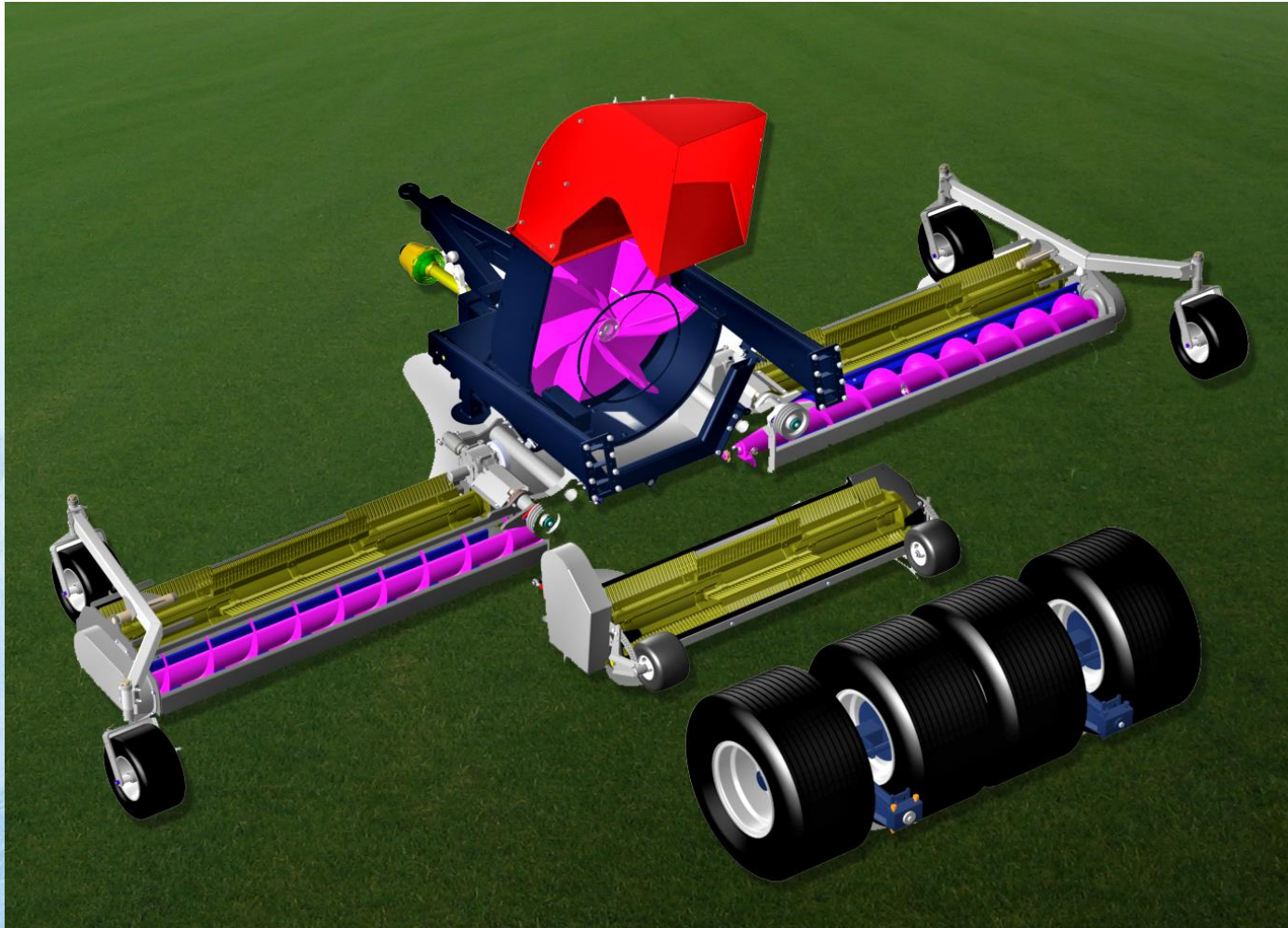

Wide area collection how it works



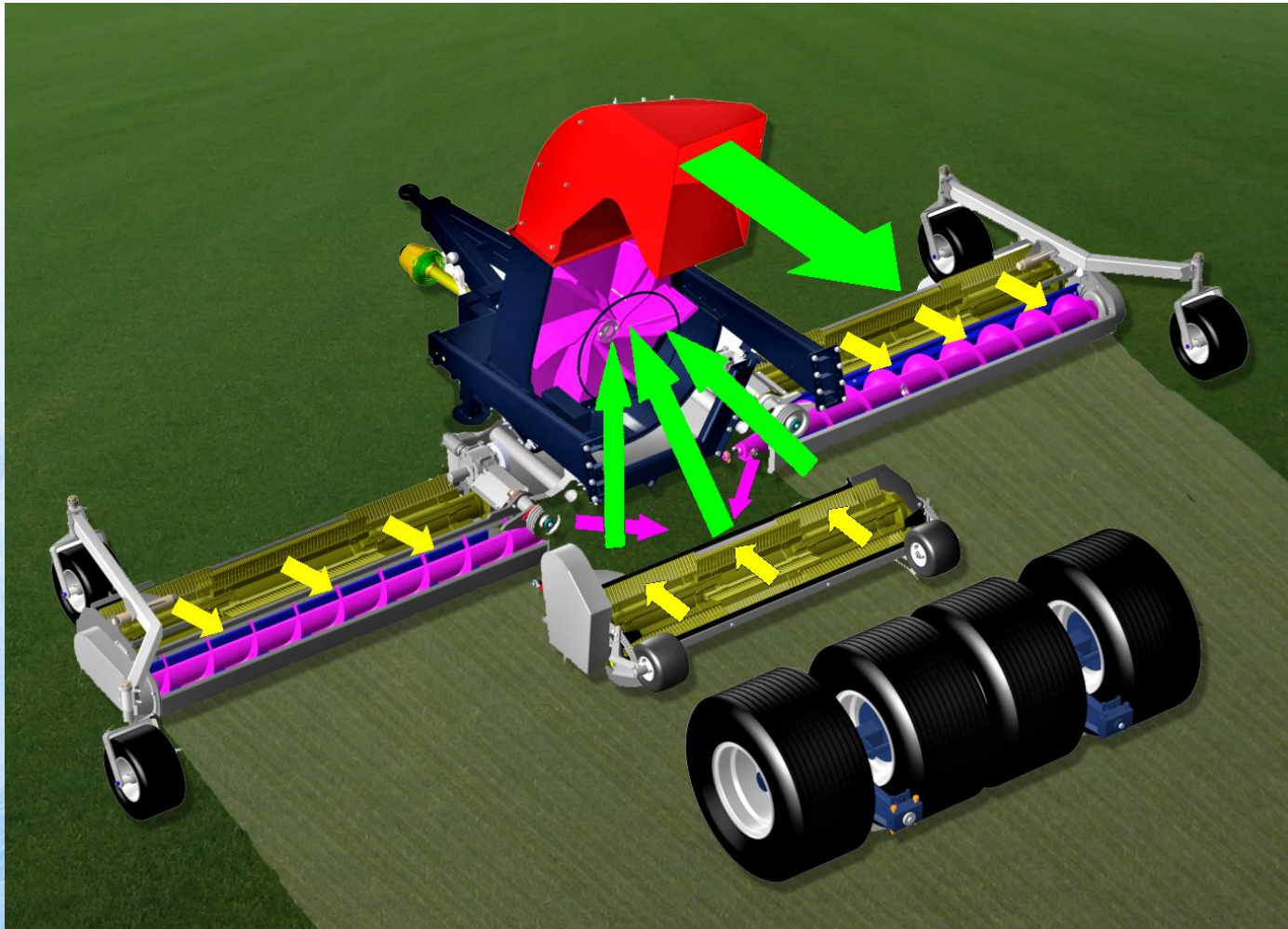

The flow of the material





Wide area cut and collect





The result





Video wide area cut and collect



# Conclusion

- Grass management is like a garden at home, you have to look after it
- Cut and collect saves time ( closure runway) and above all 100% clean grass surface
- Nice presentation from your airport





Thank you for your attention

**CARSAMPAF/13**