



U.S. Department
of Transportation
**Federal Aviation
Administration**

TAKEOFF SAFETY TRAINING AID



NTSB:

“...pilots faced with unusual or unique situations may perform high-speed RTOs unnecessarily or may perform them improperly.”

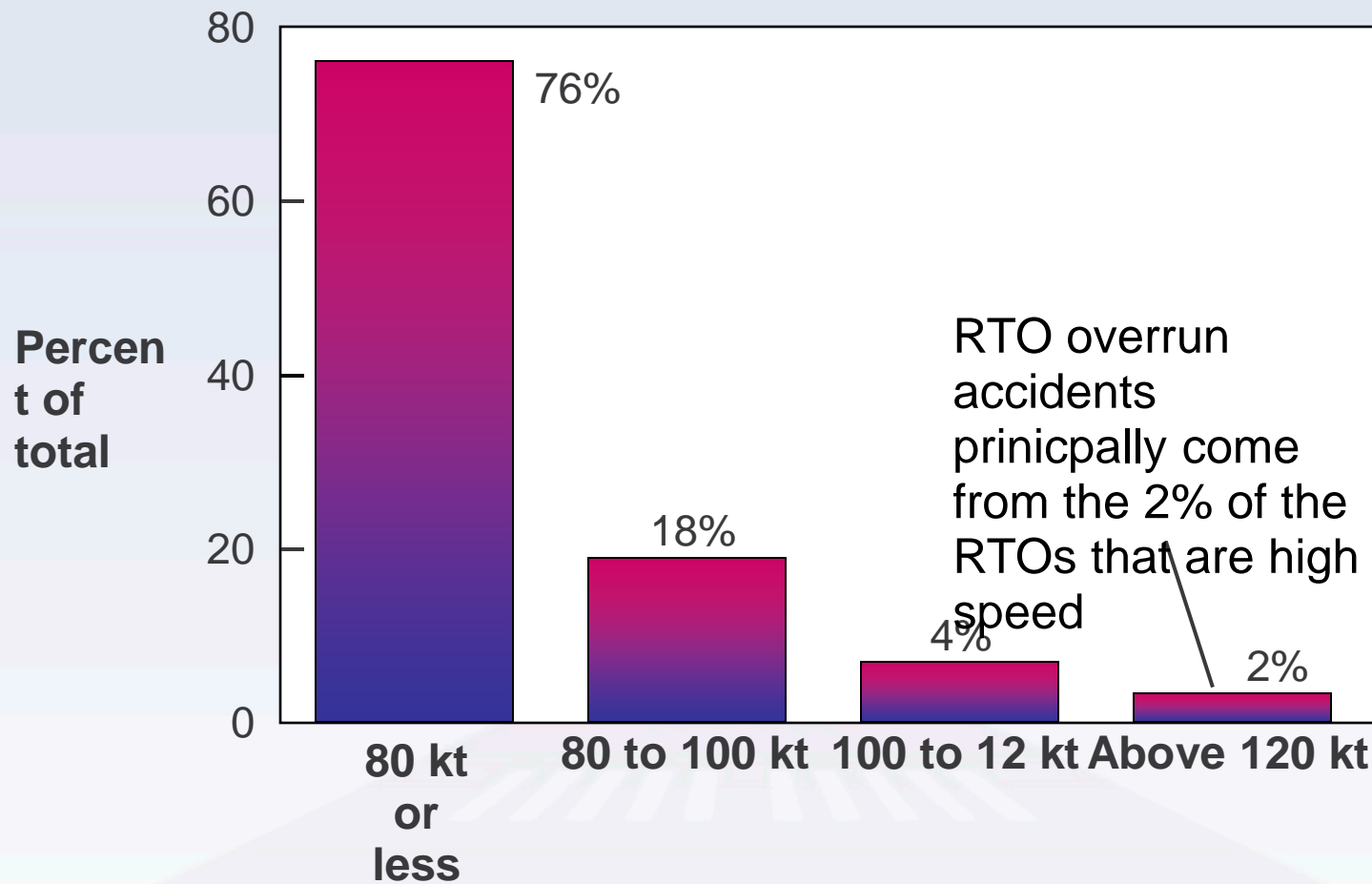

RTO Accidents/Incidents 97 Events

Initiation Speed

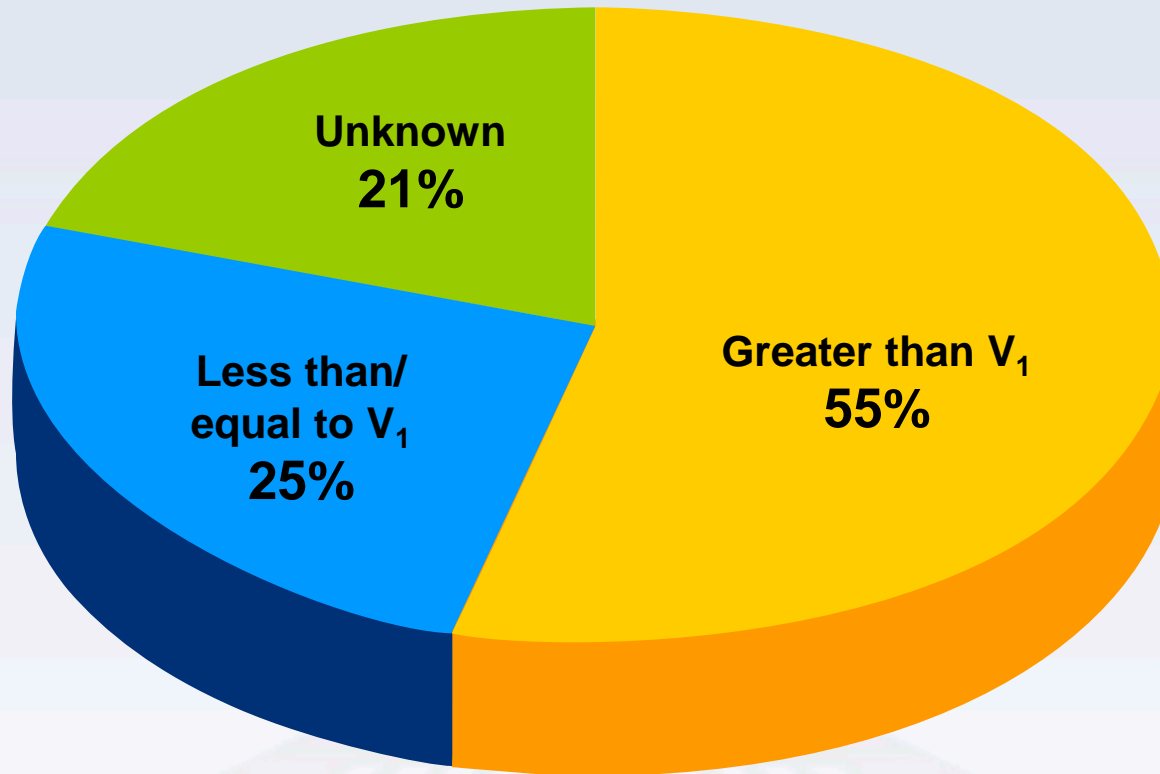

RTO Accidents/Incidents 97 Events (continued)

Runway Condition

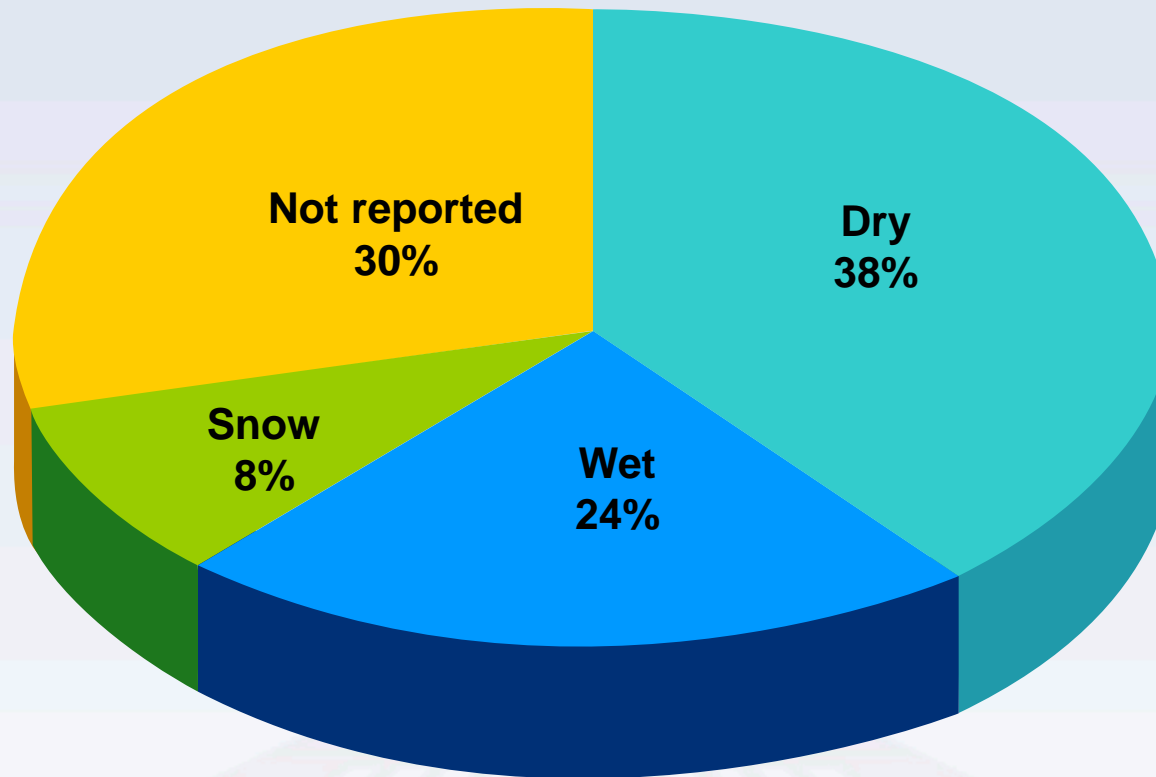

Reasons for Initiating RTO

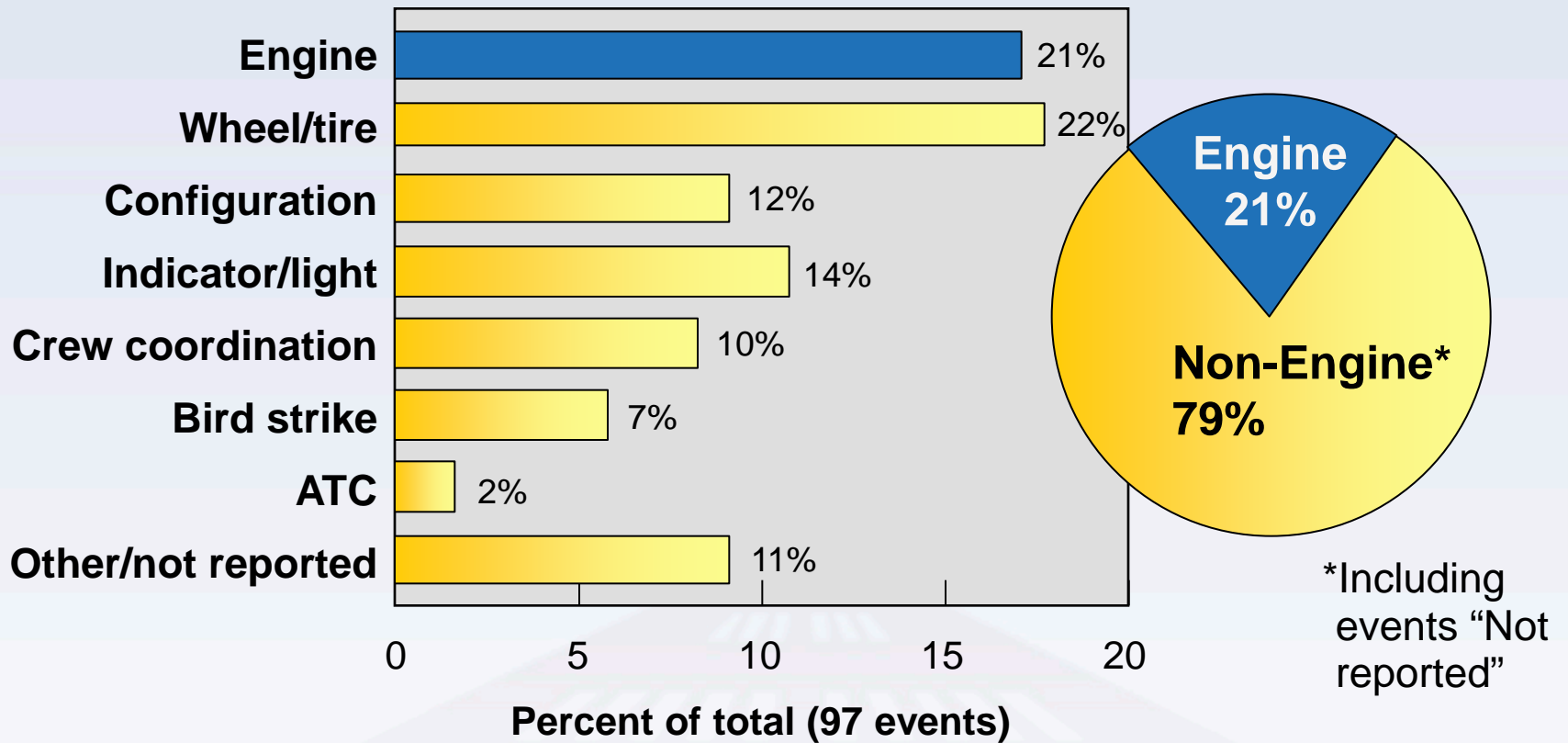

82% Were Avoidable

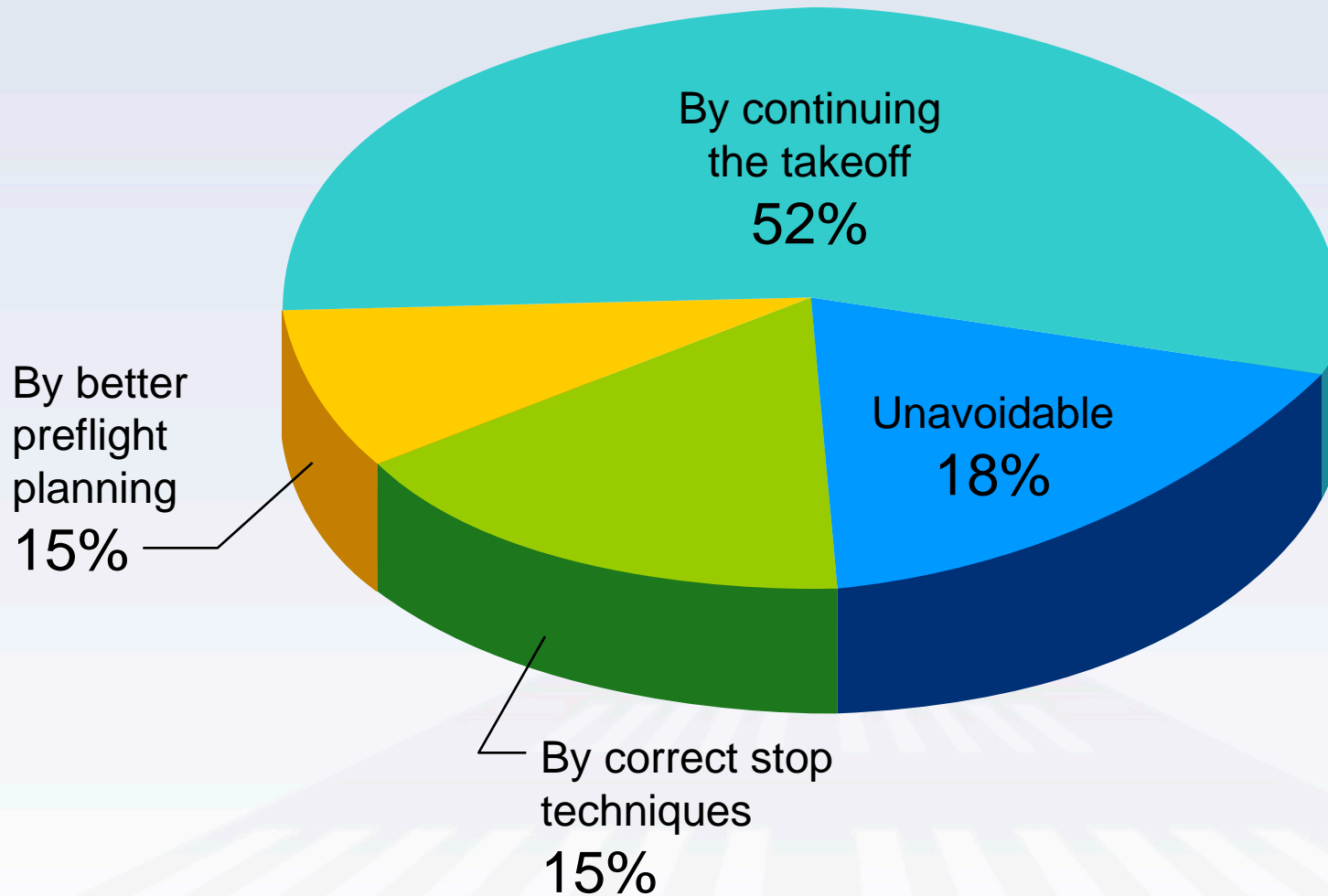

What Do The Statistics Mean?

- RTOs are not common
- Infrequency leads to complacency
- Pilot must be prepared

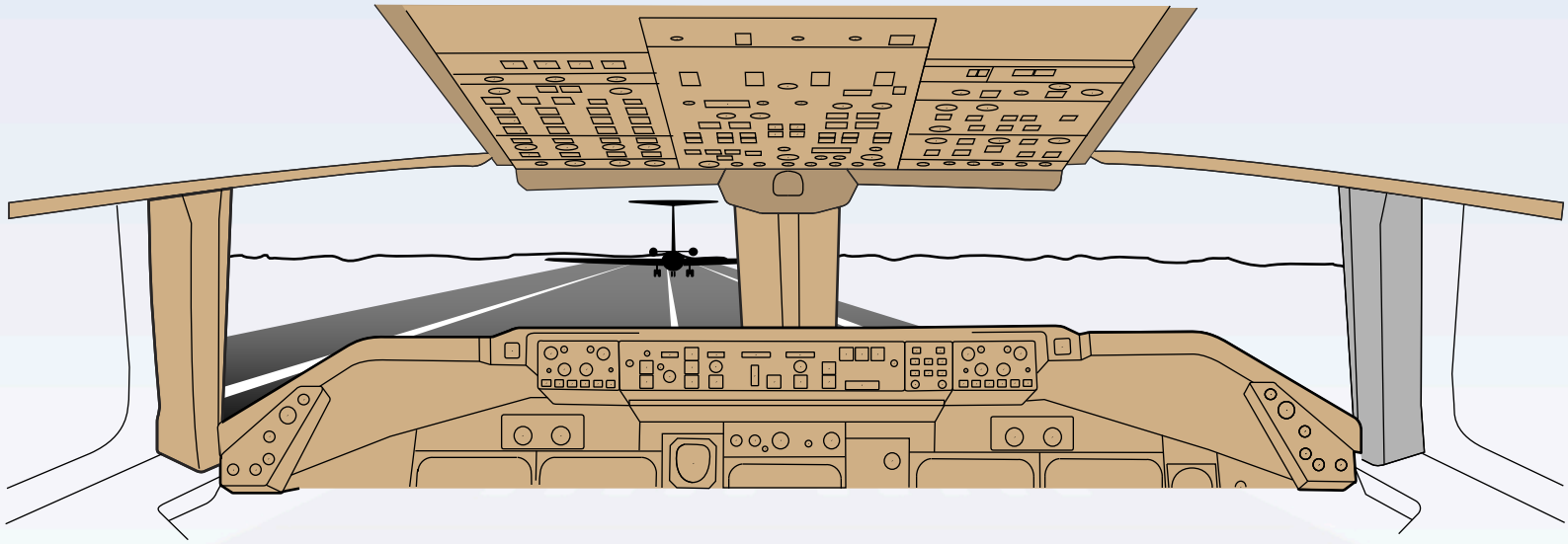

What Every Pilot Should Know

- V_1 /Takeoff rules
- Transitions
- Takeoff calculations
- Performance factors
- Configuration
- Increase safety margins

Decision Time?

“Oops, I think I should have already made my decision”



Maximum Stopping Performance

- Maximum brakes
- Thrust idle
- Speedbrakes
- Reverse thrust



Reverse Thrust

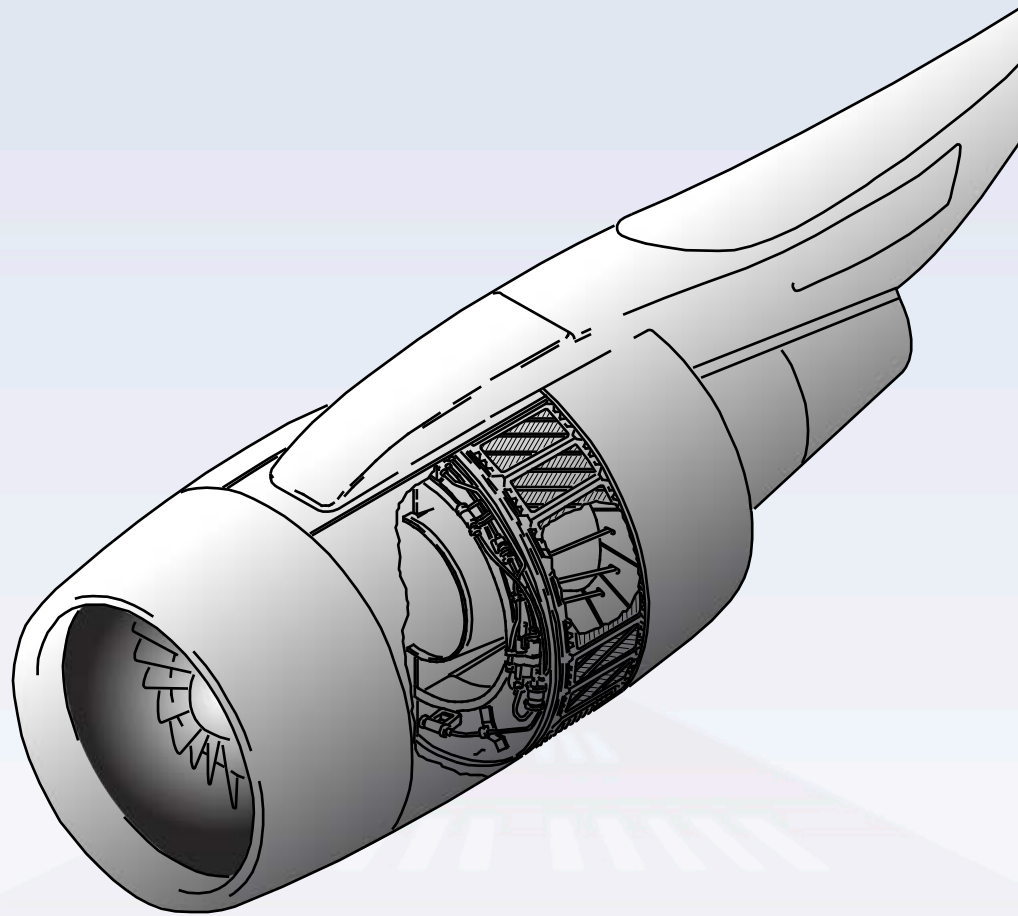

Factors Affecting Takeoff and RTO Performance

- Atmospheric conditions
- Airplane configuration
- Runway characteristics
- Engine thrust
- Human performance

Flap Selection

Typical Large Two-Engine Airplane Takeoff Performance

8,700-ft runway sea level 37° C	Flap setting			
	1	5	15	20
Runway limit weight, lb. (kg)	358,300 (162,494)	374,200 (169,705)	389,000 (176,417)	393,600 (178,503)
Climb/obstacle limit weight, lb. (kg)	414,100 (187,800)	407,300 (184,717)	393,600 (178,503)	383,000 (173,696)

Engine Bleed Air

- Bleed air reduces thrust
 - Air conditioning
 - Anti-ice
- Increase takeoff EPR or N1
 - Consult Operations Manual

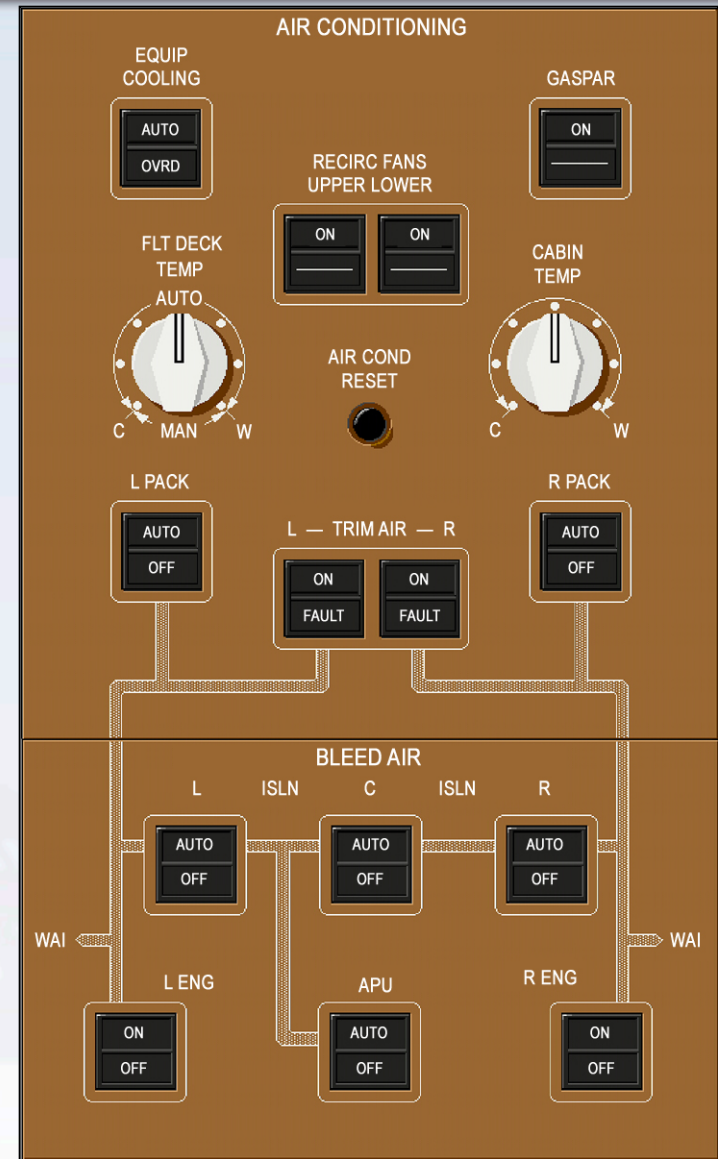

Minimum Equipment List (MEL) and Configuration Deviation List (CDL)

- May affect ability to accelerate/decelerate

ITEM	REPAIR INTERVAL		NUMBER INSTALLED		REMARKS OR EXCEPTIONS
	C	A	T	Y	
22-41-1 Wheel Brakes	C	A	T	Y	* (M) One may be inoperative (brake deactivated or line capped) provided: a) The brake is deactivated by an accepted procedure, and b) AFM decrements are applied.

MAINTENANCE (M)

1. Notify Dispatch as to method used to deactivate brake - maximum takeoff and landing weights will be reduced.
2. Deactivate the brake by one of the following methods.

BRAKE DISCONNECT TOOL INSTALLED

A. Install special brake dispatch disconnect tool (see NOTE) in place of removed antiskid shuttle valve and cap as follows. (see following illustrations)

NOTE: Part number AJ2001-1 is useable with shuttle valves S274T120-4, -6 and -8; part number AJ2000-1 is useable on all S274T120 shuttle valves.

- (1) Check that landing gear downlocks are properly installed (ref. Maintenance Manual 22-00-20) and wheels are adequately chocked.
- (2) Depressure right and center hydraulic systems.
 - a) Open ALT TR FLAPS circuit breaker on main power distribution panel P6 and attach DO-NOT-CLOSE identifier, to deactivate secondary power source to flaps.
- (4) Release parking brakes by supplying electrical power and depressing both brake pedals fully and releasing. Check that PARK BRAKE light on P10 panel extinguishes.

NOTE: Parking brakes may be released by operating either the Captain's or First Officer's brake pedals.

- (5) Discharge hydraulic pressure from parking brake accumulator by use of either the Captain's or First Officer's brake pedals. Fully depress and release both pedals at the same time, seven times minimum, until the cockpit brake pressure gauge no longer moves down.

(Continued)

06-01-91 D6307902 Page 2-22-41-1.0

**** Check Revised Procedures ****

Tires and Brakes

Heat Buildup

Excessive braking

Long taxi

Foreign objects

Wheel cracks

Visual Inspection

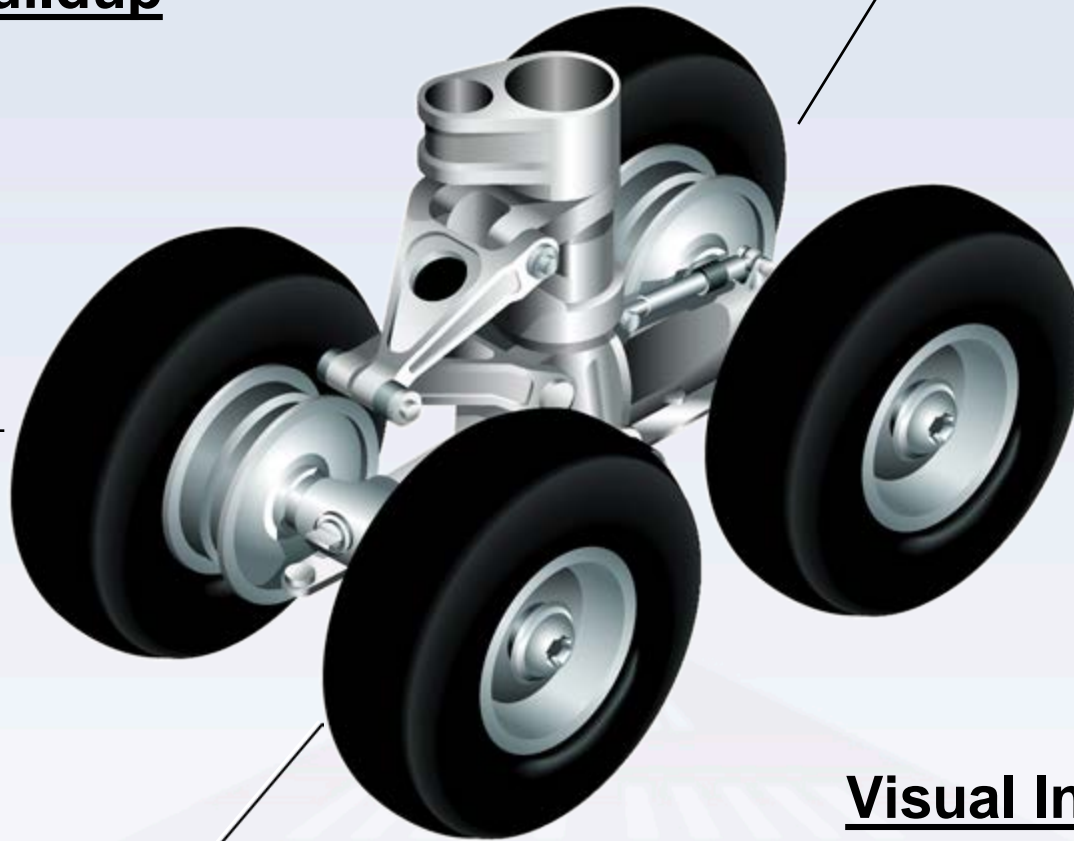

Runway Surface Condition Wet or Contaminated

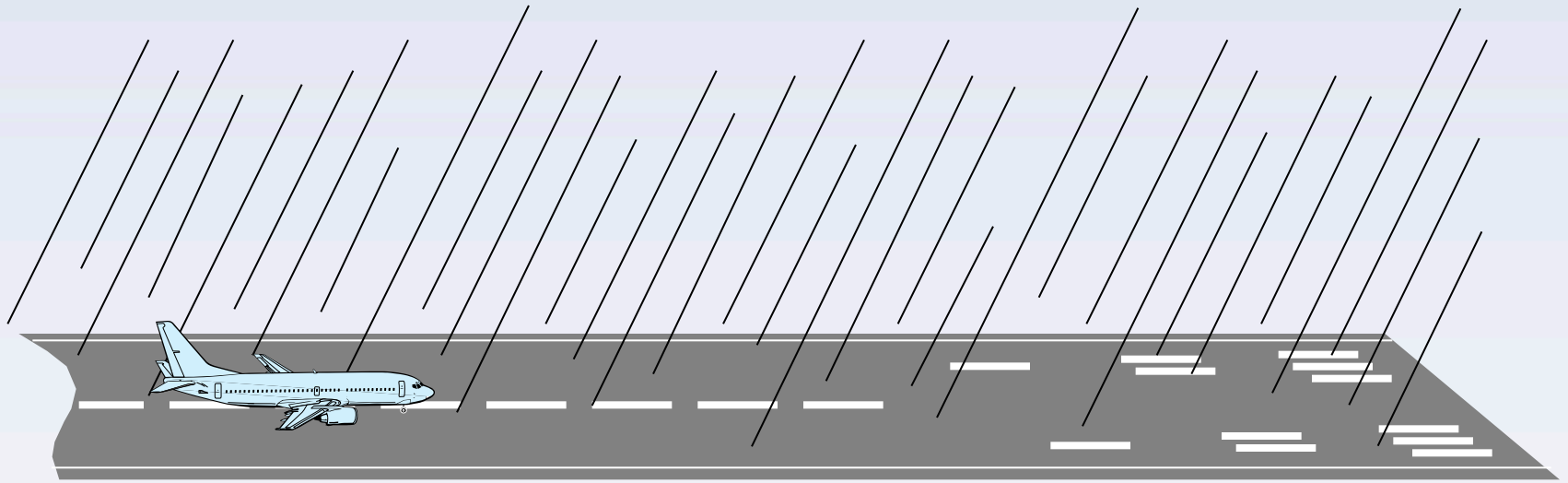

Affects friction between runway and tires

The Crew

- Preflight briefing
- Cockpit callouts
- Positive action if malfunction occurs

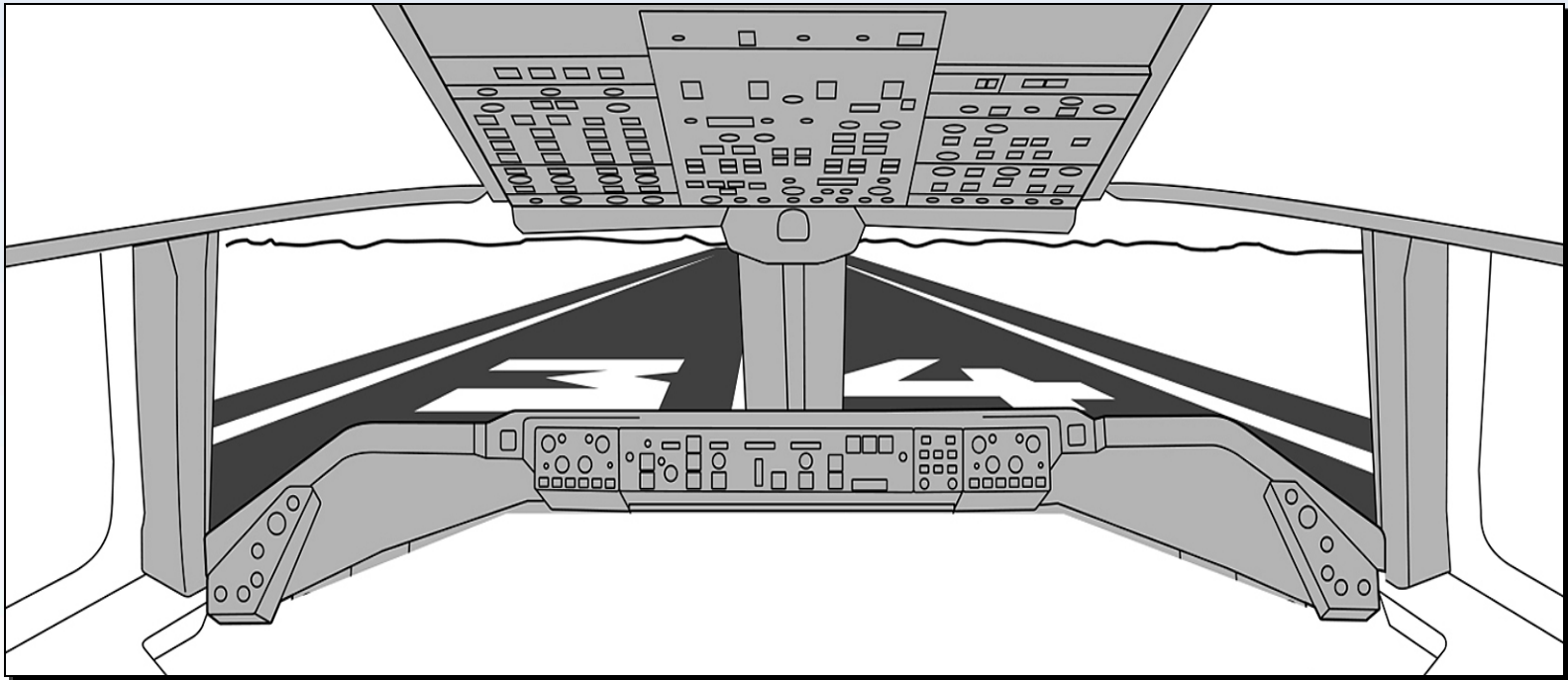

Items to Reject For

Low speed:

- System failures
- Unusual noise or vibration
- Tire failure
- Abnormal acceleration
- Unsafe takeoff configuration
- Fire or fire warning
- Engine failure
- Unsafe or unable to fly

High speed:

- Engine failure or fire
- Unsafe or unable to fly

Timely V1 Callout



Finish the callout as the airplane reaches V_1

Ensures a “No Go” decision will not be made after V_1

TAKEOFF SAFETY

TRAINING AID

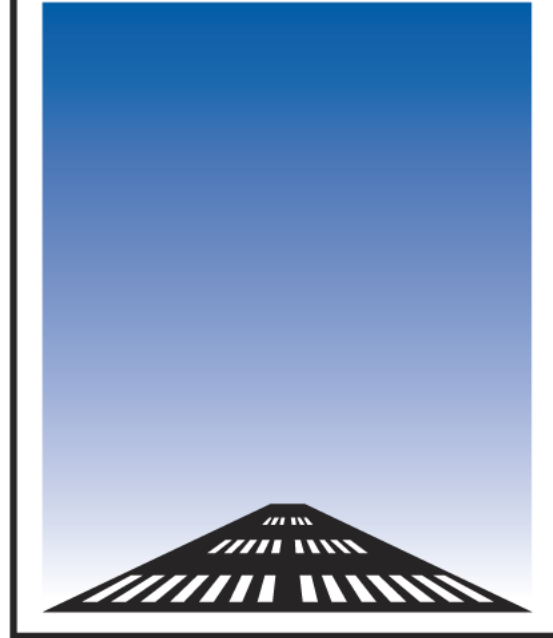

Be ready to **Decide**

Be ready to **Act**