



SAM REDDIG

(South American Digital Network)

Luis Alejos
SAM REDDIG Administrator
Lima, Peru - July 2011



The Region





The REDDIG Concept

- The REDDIG is the result of the regional cooperative spirit and effort between all SAM States now reaching other regions.
- The objective, share an own network for the current and future aeronautical telecommunications services.



The REDDIG solution





The REDDIG Administration

- Provides the aeronautical communications services with the highest standards in quality and availability since 2003
- Optimizes the utilization of resources
- Implements new aeronautical applications and services



The REDDIG Platform

- Satellite technology: Full Mesh & BoD
 - Satellite: IS-14
 - Transponder: A28CV / A28CV
 - Space Segment: 4.38MHz
- Multi-protocol support: FR & IP
- Integration of aeronautical applications for voice (analog & digital) and data (legacy & advanced)



SAM REDDIG Sat Net Operation

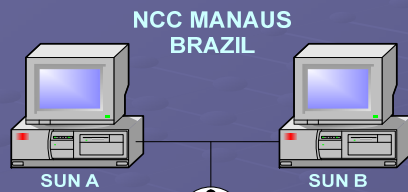

Stop
Start

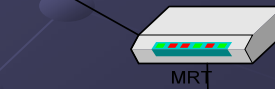
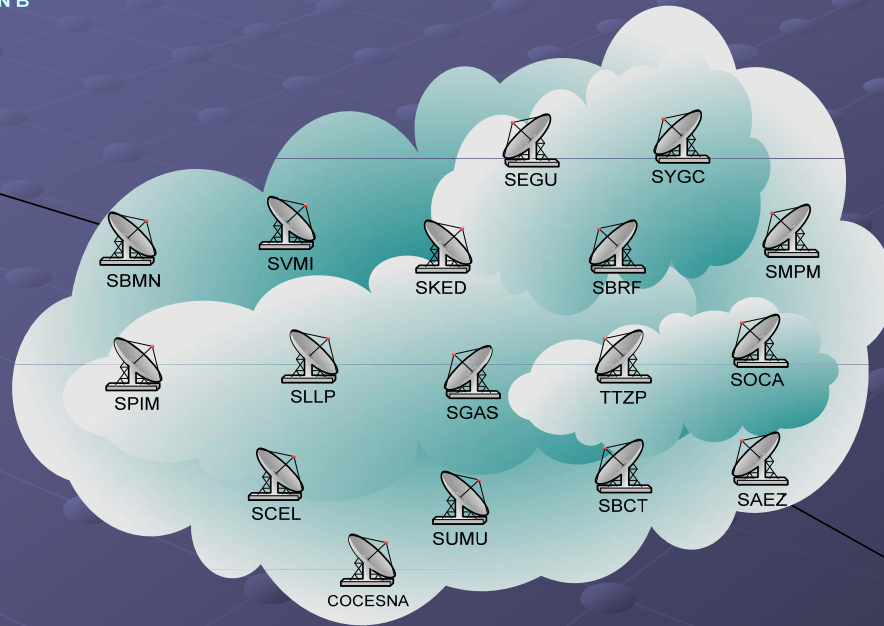
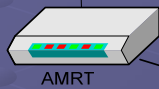

Stop
Start



FR PVCs: Full Mesh

IP PVCs: Dual Star
Manaus & Ezeiza



REDDIG Node Locations

ESTADO/STATE	NODO/NODE		COORDENADAS/ COORDINATES	
			LATITUD/ LATITUDE	LONGITUD/ LONGITUDE
Argentina	Ezeiza	SAEZ	34° 49' 25" S	58° 31' 43" W
Bolivia	La Paz	SLLP	16° 30' 22" S	68° 11' 09" W
Brasil	Manaus	SBMN	03° 01' 52" S	60° 02' 29.9" W
	Recife	SBRF	08° 08' 15" S	34° 55' 29" W
	Curitiba	SBCT	25° 24' 06" S	49° 14' 07" W
Chile	Santiago	SCEL	33° 23' 27" S	70° 44' 18" W
Colombia	Bogotá	SKED	04° 42' 05" N	74° 08' 48" W
Ecuador	Guayaquil	SKGU	02° 09' 29" S	79° 53' 02" W
Guyana	Georgetown	SYGC	06° 25' 25" N	58° 15' 14" W
French Guyana	Cayenne	SOCA	04° 49' 11" N	52° 21' 38" W
Paraguay	Asunción	SGAS	25° 14' 24" S	57° 31' 09" W
Peru	Lima	SPIM	12° 01' 27" S	77° 06' 20" W
Suriname	Paramaribo	SMPM	05° 27' 10" N	55° 11' 16" W
Uruguay	Montevideo	SUMU	34° 50' 15" S	56° 01' 49" W
Venezuela	Maiquetía	SVMI	10° 36' 12" N	66° 59' 26" W
Trinidad & Tobago	Piarco	TTZP	10° 37' 48" N	61° 31' 12" W
(*) Honduras	Tegucigalpa	COCES	14° 03' 36" N	87° 13' 12" W

(*) MEVA II Node (COCESNA) interconnecting to REDDIG network



REDDIG Node (Block Diagram)

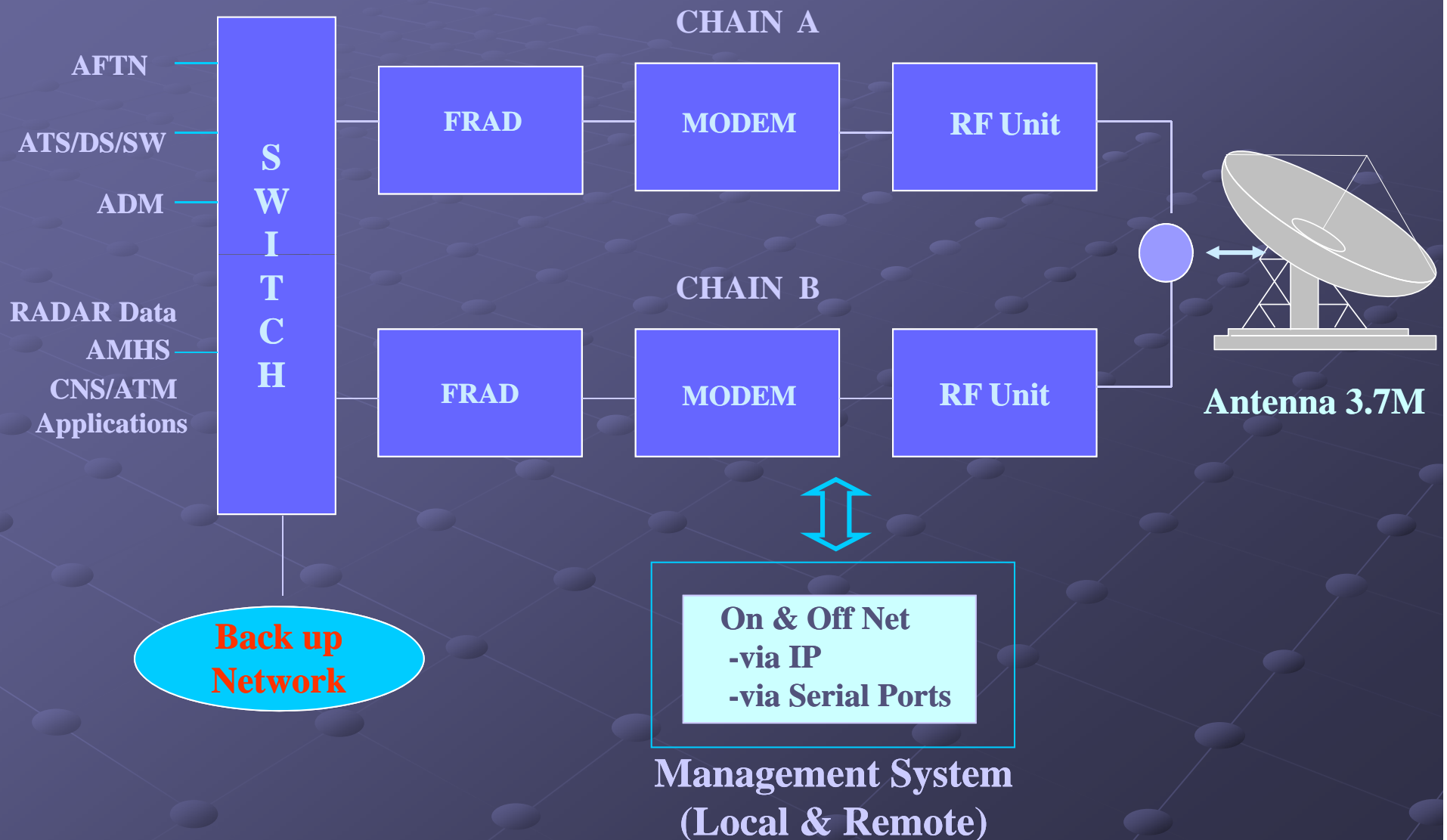



Management System

- IP based network
- Communications Server: **Linux PC**
 - ✓ Protocols: TELNET, HTTP, SNMP, FTP
 - ✓ Applications
 - FRAD: CxAccess, Minicom, Web Page
 - Linkway: NCC Linkway, Minicom
 - SSPA: Web Page & Linux commands
 - BBSW and WGSW: Linux commands
- On net: via Linkway Terminal
- Off net: via Dial-up Modem



Monitoring & Control (Local & Remote)

< SSPA Control > < Chain Control > < Automatic Mode Control >

Status Summary as on Mon Sep 30 11:25:22 GMT 2002

Redundancy: Auto mode is DISABLED

SSPA units:

UNIT A: SSPA No. 1 Status: Attenuation = 17.7 dB, External Mute = Off, Internal Mute = ON, RF Power \leq 0 dBm, No Alarms are active

UNIT B: SSPA No. 1 Status: Attenuation = 20.0 dB, External Mute = Off, Internal Mute = ON, RF Power \leq 0 dBm, No Alarms are active

Switches: Waveguide switches are in position A, Baseband switch is in position A;

Link Management: Modern link on FRAD-MPS-A is UP, Modern link on FRAD-MPS-B is DOWN;

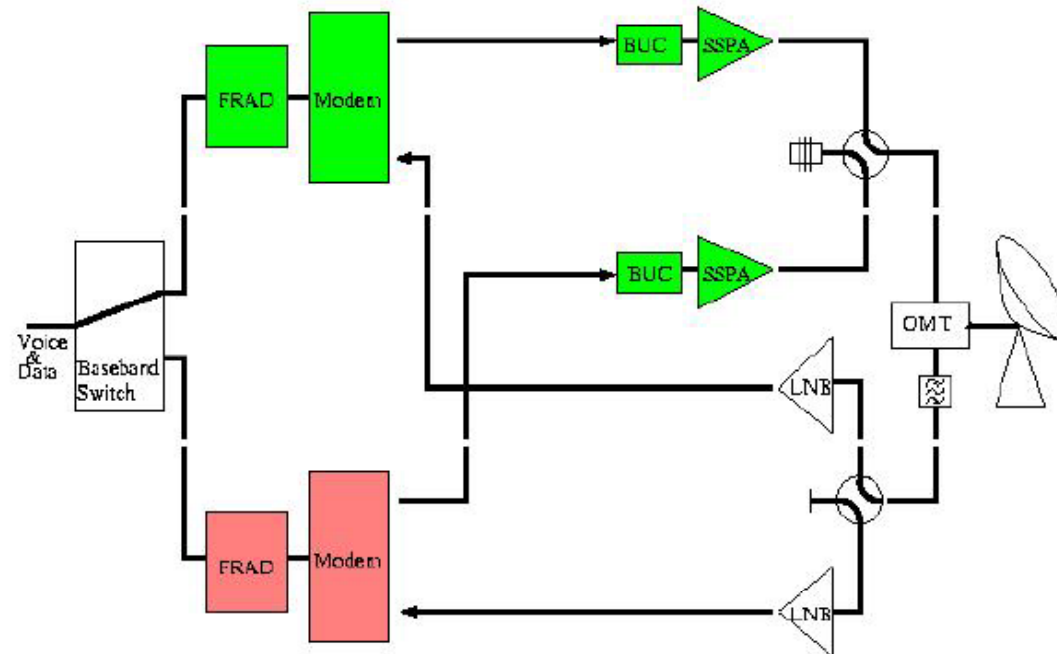

COLOR LEGEND: OK / On-line Down / Critical Alarm Unknown / Secondary Alarm



The REDDIG Platform

- Solution that integrates the applications based on the IP suite
 - ✓ Employing just one physical port for all applications running over IP.
 - ✓ Configuring the additional PVCs when they are required.
 - ✓ Prioritizing the traffic with throughput management by application.



Network Interconnections

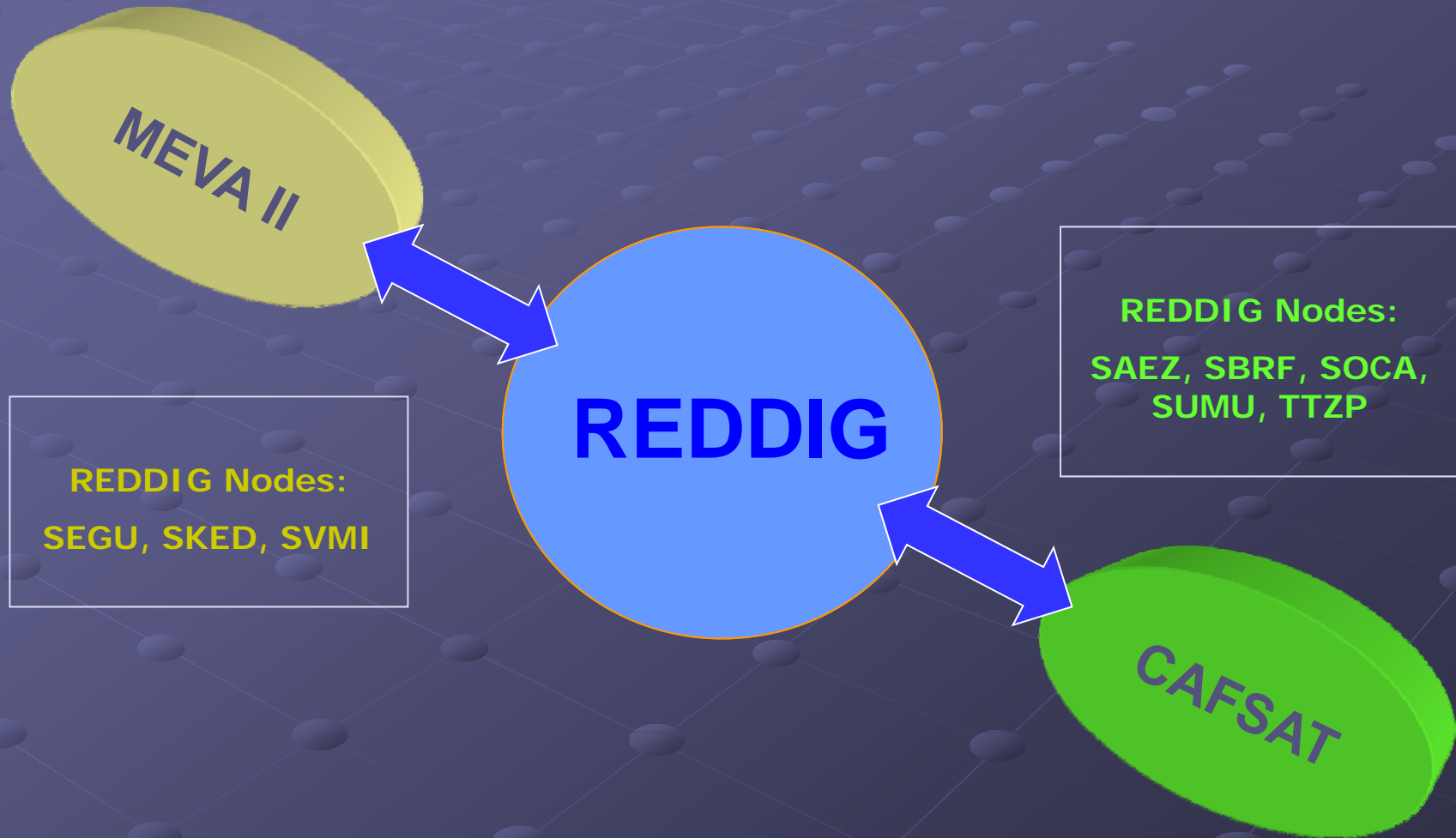



Availability

REDDIG Network Availability





Statistics

REDDIG 2010 Atenciones a los Nodos = 203

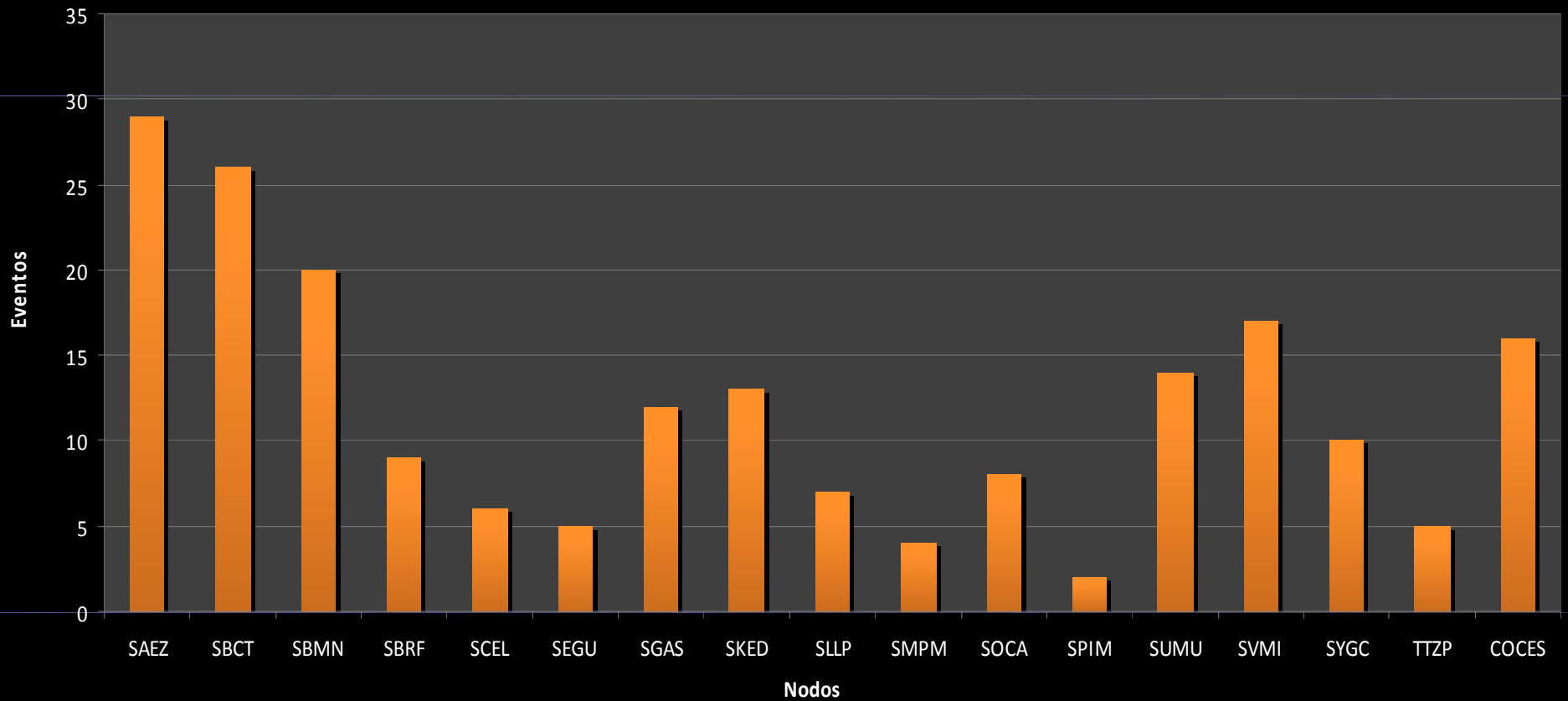



Statistics

REDDIG 2010 Distribución de atenciones

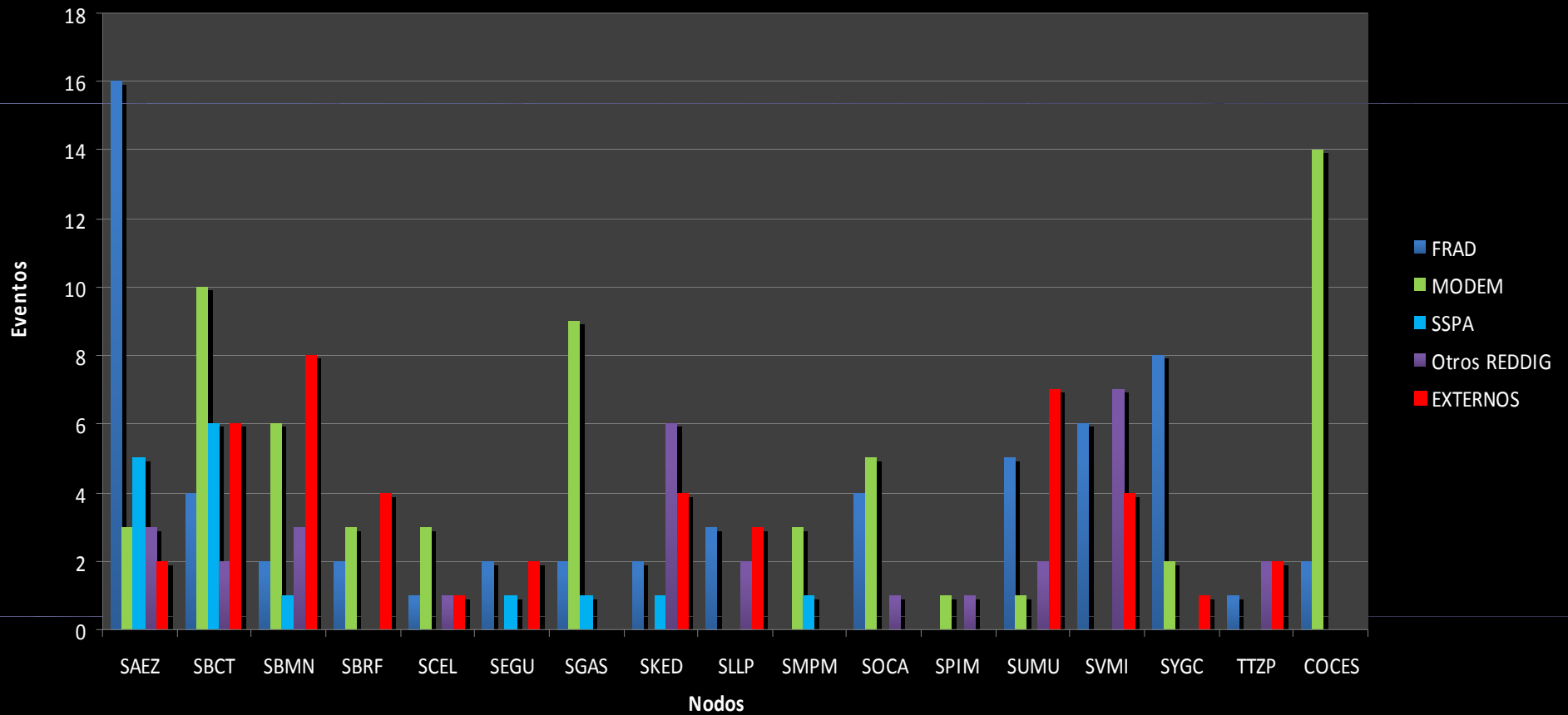



Statistics

REDDIG

Distribución de las atenciones por categoría de equipo

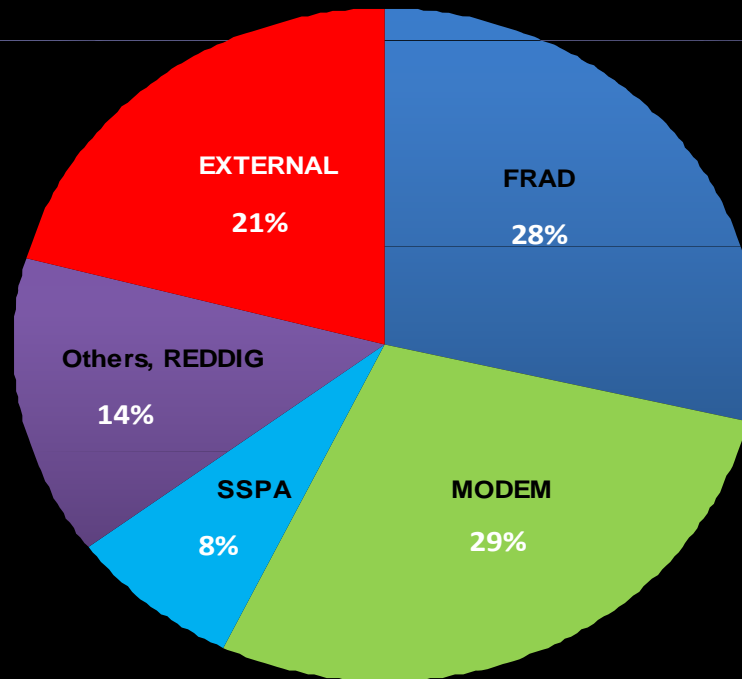

- 1
- 2
- 3
- 4
- 5



Migration to REDDIG II

- Current equipment:
Manufactured in 2001 / 2002.

FRAD and MODEM as well as miscellaneous equipment not in production since 2009.

Spare parts not in production either.
- Migration for continuity of services with a new platform of latest technology
- Migration will be transparent to users