

2. Basic Concepts

Contents

2 Basic Concepts

- a. Link configuration
- b. Topology
- c. Transmission mode
- d. Classes of networks

a. Link Configuration

Data links

A direct data link is one that establishes a transmission path between two stations for direct propagation of signals from the transmitter to the receiver without any other intermediate devices, except for amplifiers/repeaters that increase the strength of the signal.

Classification of data links

- **According to their configuration:**
 - **Point-to-point**
 - **Point-to-multipoint**
- **According to their availability:**
 - **Dedicated line**
 - **Switched line**

According to their configuration

Point-to-point link: Provides a direct link between two stations, which are the only ones that share the medium.

Multipoint link: More than two stations share the medium. Also known as multidrop link.

Types of connections: point-to-point and multipoint

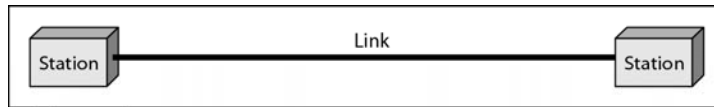

a. Point-to-point

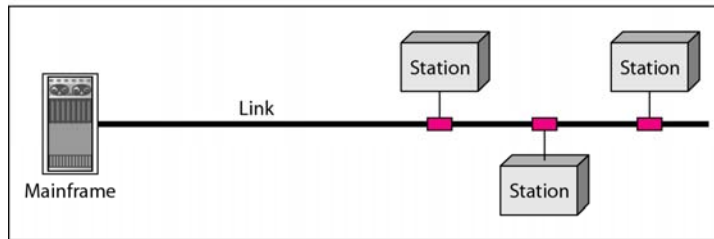

b. Multipoint

According to their availability

Dedicated line: For exclusive and private use by one user, and for which a fixed monthly rate is paid. Also known as leased line.

Switched line: Is the one established through switches, especially telephone switches. This line is available when two ends connect as a result of a successful call. Billing is based on usage.

Classification of circuits

- According to the number of wires
- According to the mode of operation
- According to the type of transmission

According to the number of wires

2-wire circuit: This circuit only has two wires, which are used for transmitting and receiving.

This communication may be deferred in time, (semiduplex) or frequency-division multiplexing (FDM) may be used to separate the transmission from the reception within the bandwidth of the channel.

4-wire circuit: Has 2 wires available for transmitting in one direction and 2 wires for transmitting in the opposite direction.

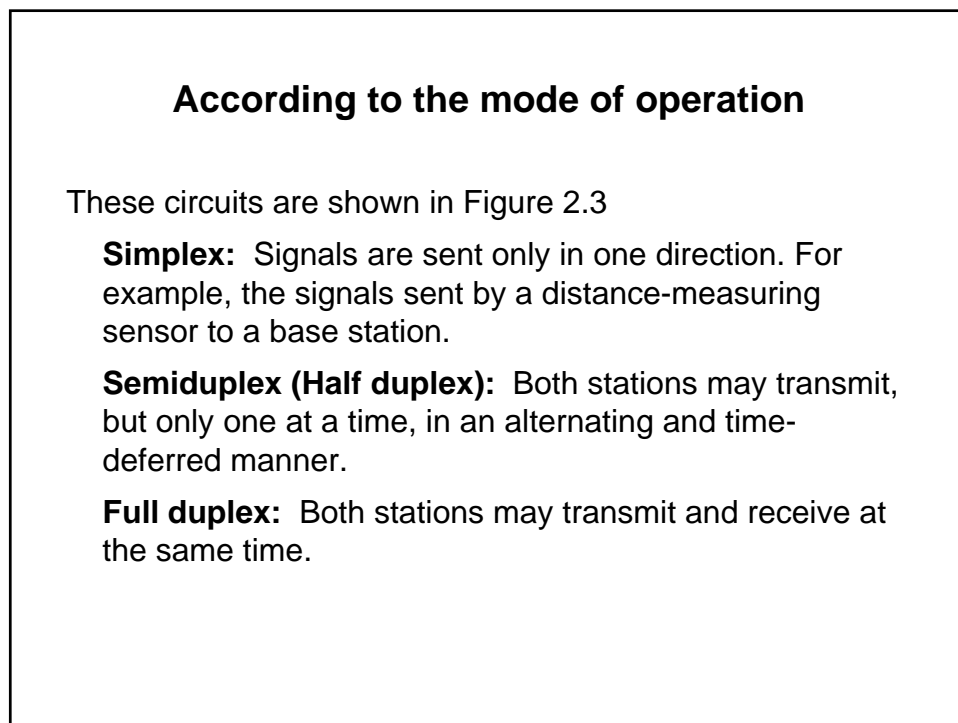
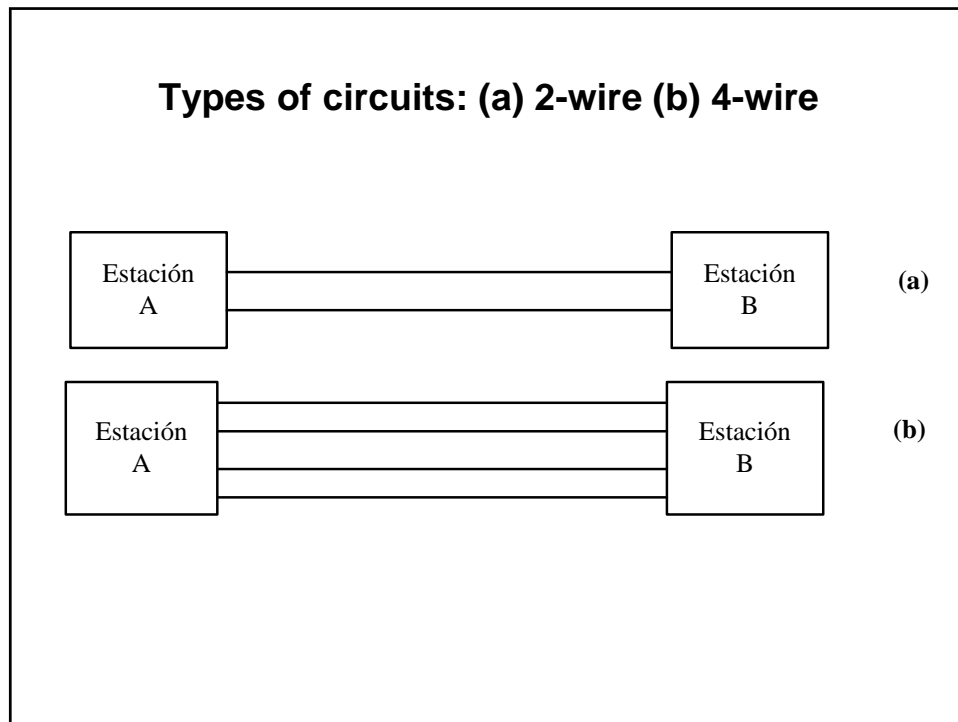

Data flow (simplex, half-duplex, and full-duplex)

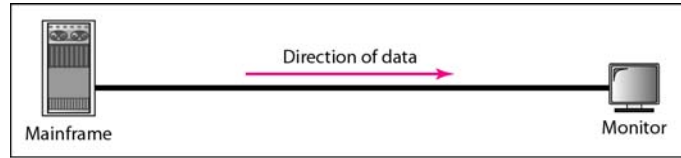

a. Simplex

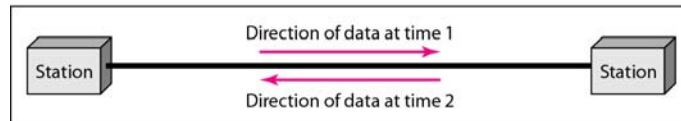

b. Half-duplex

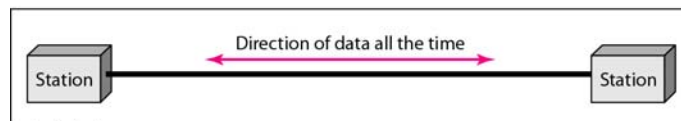

c. Full-duplex

b. Topology

Categories of topology

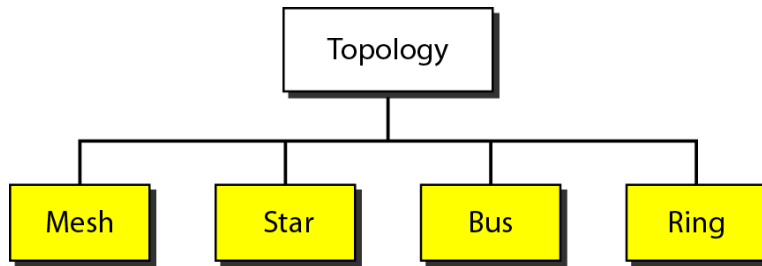

A fully connected mesh topology

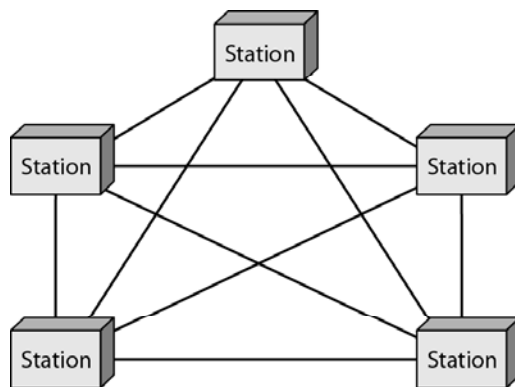

A star topology connecting four stations

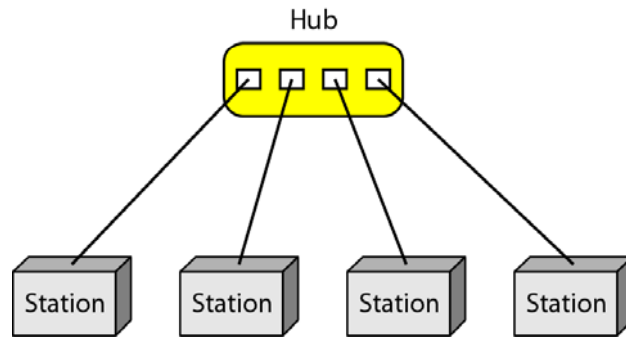

A bus topology connecting three stations

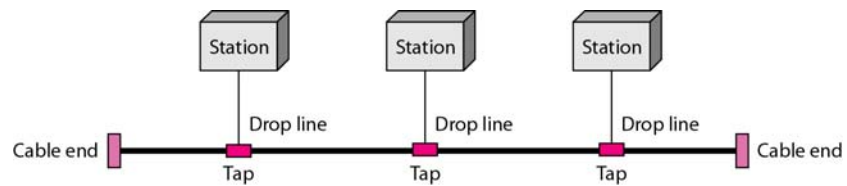

A ring topology connecting six stations

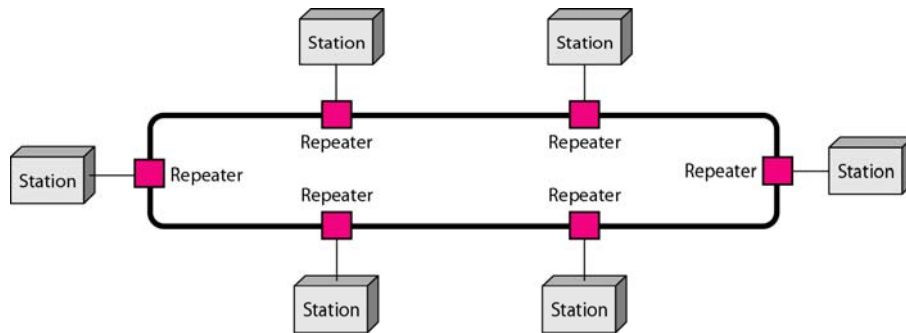

c. Transmission mode

According to the type of transmission

- Parallel transmission
- Serial transmission
 - Asynchronous
 - Synchronous

According to the type of transmission

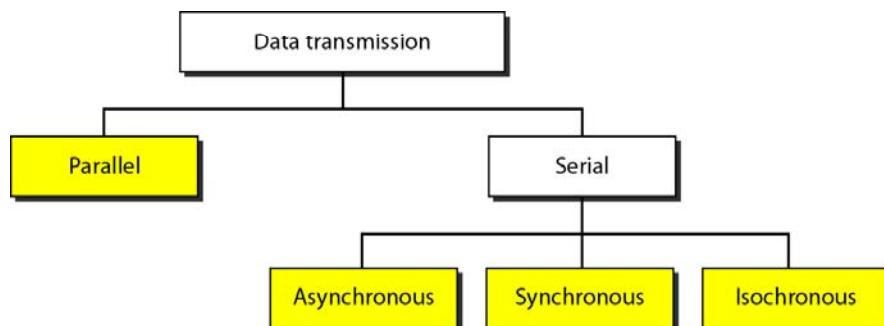

Parallel transmission

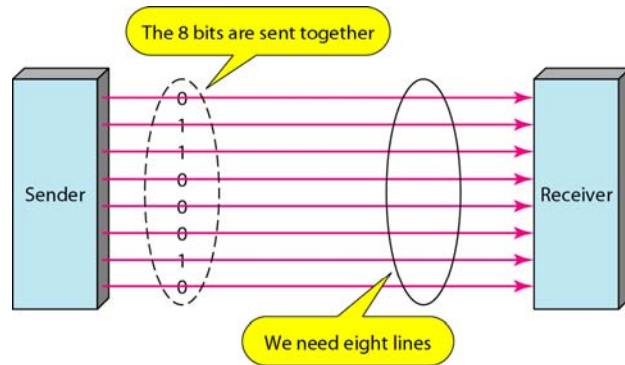

Serial transmission

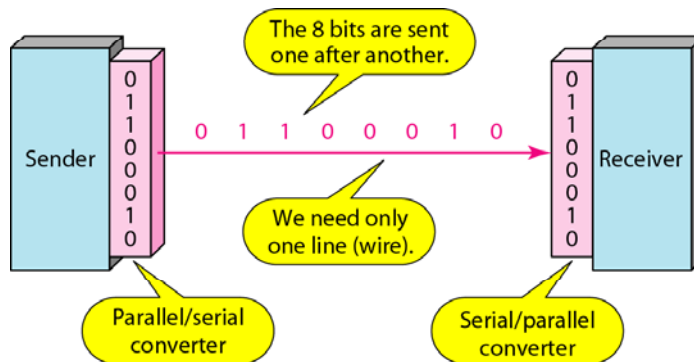

Asynchronous transmission

A method for sending data in which intervals between characters may have different duration.

Since asynchronous characters are used, no additional synchronization is required.

It is known as start-stop transmission.

It requires a start bit to indicate the beginning of a character, and one or two (sometimes 1.5) bits to indicate the end of the character.

Asynchronous transmission

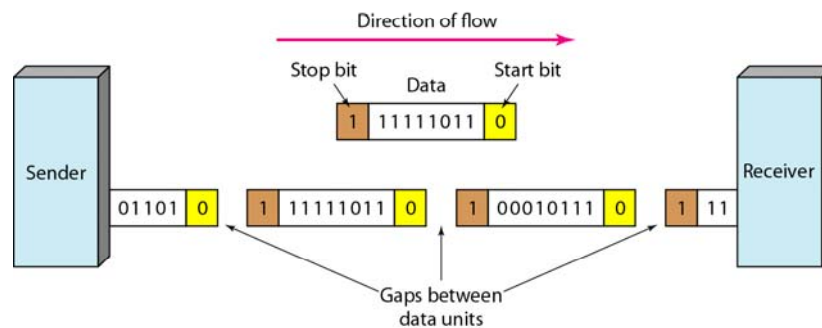

Synchronous transmission

Characters and data bits are transmitted at a fixed rate, with the transmitter and receiver synchronized.

Consequently, there is no need for a start bit and a stop bit around each character, thus improving efficiency.

Synchronous transmission

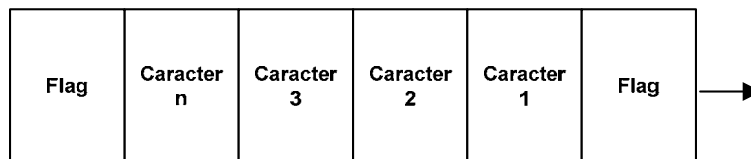

d. Classes of networks

General communications network

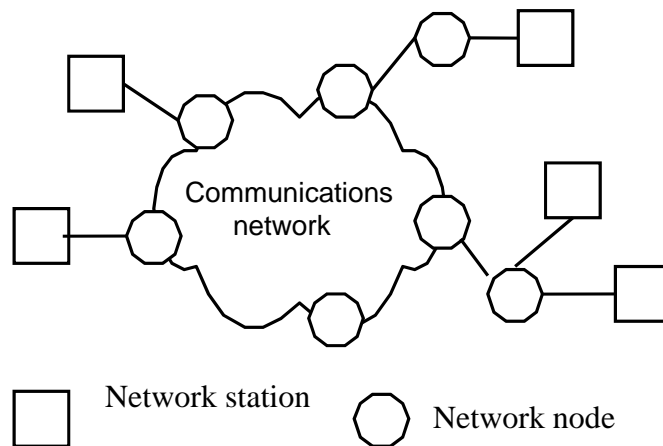

Types of networks

- a) Switching networks
 - Circuit switching networks
 - Packet switching networks
- b) Broadcasting networks
 - Local area networks (LANs)
 - Wireless packet networks
 - Satellite networks

Switching network

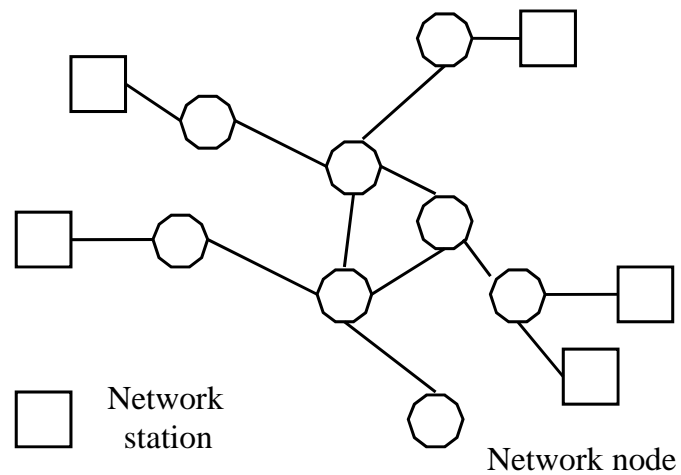

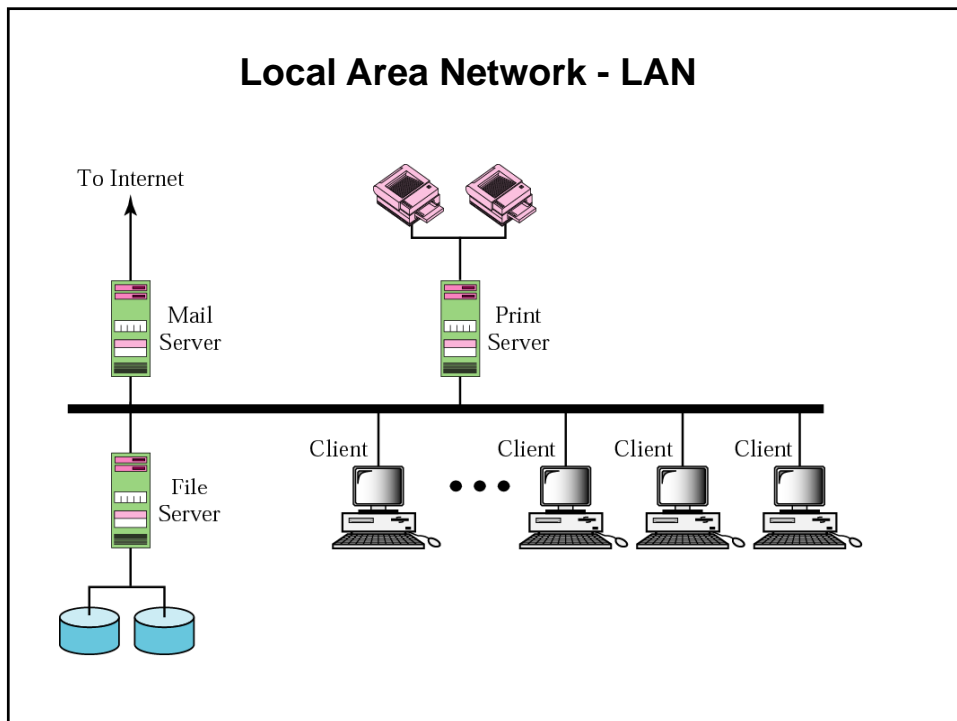
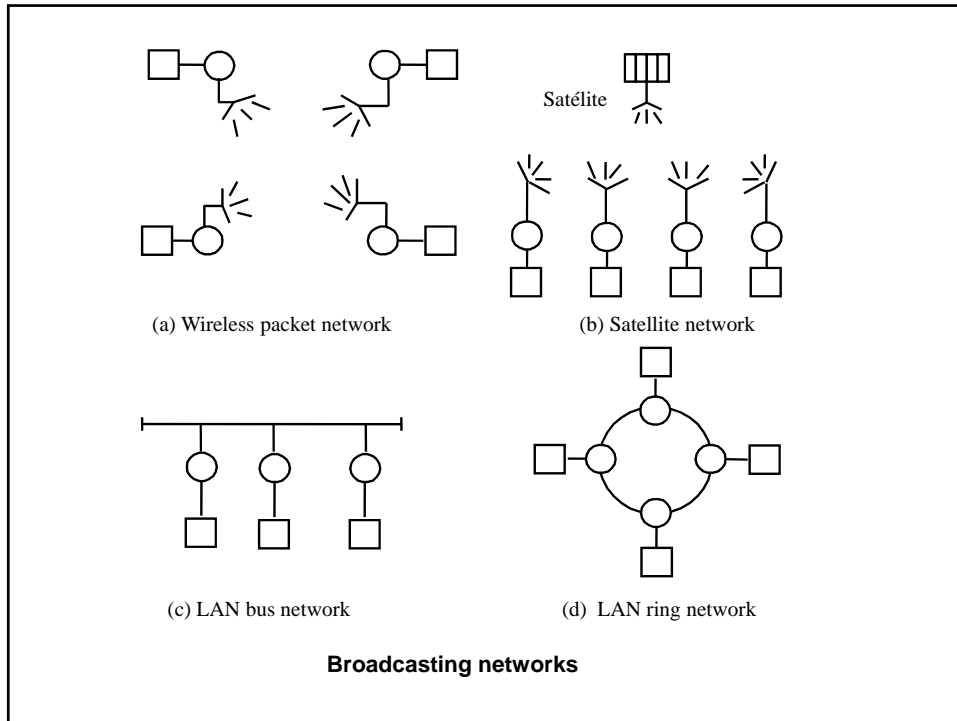

Metropolitan Area Network - MAN

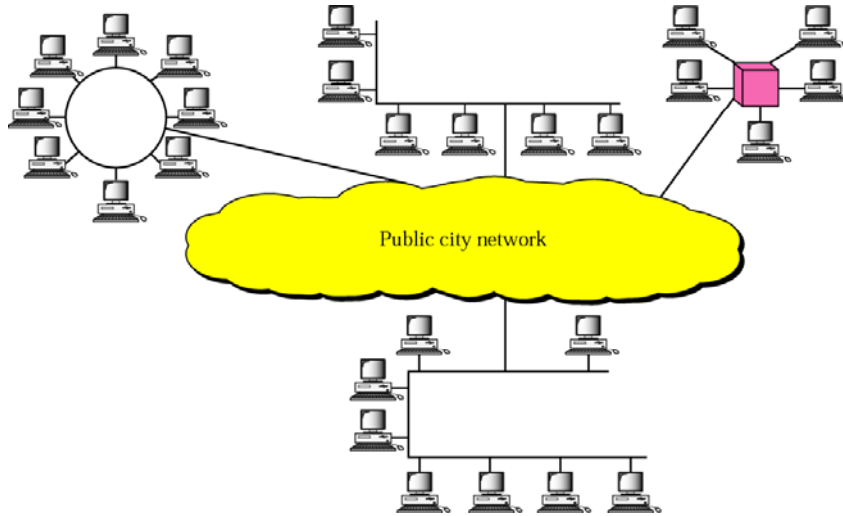

Wide Area Network - WAN

