



Agenda Item 3: Analysis of considerations for MEVAII/REDDIG integration phase

**TECHNICAL-OPERATIONAL ANALYSIS FOR THE MEVA II / REDDIG
INTERCONNECTION SOLUTION**

(Presented by the Secretariat)

Summary

This working paper presents considerations and technical-operational-administrative-institutional aspects analyzed in previous MEVA II / REDDIG coordination meetings to continue with the technical-operational analysis for the MEVA II / REDDIG interconnection solution.

References:

- Reports of MEVA II/REDDIG Coordination Meetings
- GREPECAS/14 Report

1 Background

1.1 During the first MEVA II/REDDIG coordination meetings: First MEVAII/REDDIG Coordination Meeting (Lima 11-12 November 2002), Second MEVAII/REDDIG Coordination Meeting (Lima 20-22 March 2006), Third MEVAII/REDDIG Coordination Meeting (Ciudad de México 26- 28 July 2006) and the First Meeting of the MEVAII/REDDIG Interconnection Task Force (3 - 5 May 2006) the homogeneous integration of MEVA II and REDDIG networks was analyzed, including the cost-benefit analysis, necessary resources definition, operation proposal elaboration, required services control and other aspects related to the achievement of this objective.

1.2 For the III MEVA II/REDDIG Coordination Meeting (MR/3) agreement was reached regarding that the total homogeneous or complete integration solution represented the best technical operational solution, since this would permit having a unified control, making easiest management and implementation of required services between CAR and SAM Regions. However, it was determined that the implementation of the integral solution as an initial stage would be difficult to achieved considering existing divergent aspects in the REDDIG and MEVA II operation and administration. In this regard, Conclusion 3/1 was defined “*Technical-Operational Analysis for the MEVA II / REDDIG Interconnection Solution*” in which it was concluded that the based option based in the technical-

operative analysis would be the integration, but the most viable in the initial stage would be the interconnection, with the objective of the networks integration after a period of five years.

1.3 During the GREPECAS/14 Meeting this same conclusion was agreed and extended in the following way: that the integration of the MEVA II and REDDIG networks under a sole network control unit represented the best option, but due to administrative schemes of the two VSAT networks they could hardly be changed at present. This option was considered for implementation after a period of five years starting 2006. During the present five-year period the interconnection of the referred VSAT networks would be established, which will include, principally, the installation of a MEVA II MODEM in the REDDIG nodes of Colombia and Venezuela, as well as a REDDIG MODEM in the MEVA II node of Honduras (COCESNA). Under this interconnection solution the two networks will continue operating independently and manager through their respective control centre.

1.4 The integration/interconnection of digital networks with the purpose of improving and making more efficient aeronautical services, having the best profit of existing capacities en each digital network has been formulated since RAN/CAR/SAM/3 Meeting and coordinated through GREPECAS and the other regional planning groups. More details to these references are being presented in **Appendix A** to this working paper.

2. Discussion:

2.1 The interconnection/integration between digital networks in the CAR/SAM Regions has as purpose to improve effectiveness, efficiency, quality and availability of aeronautical fixed service (AFS) voice and data communications circuits, reducing costs and facilitating the ATN introduction and its applications in an evolutive manner.

Networks integration advantages

2.2 Among the principal advantages that would be obtained with an integration of both networks it can be mentioned:

- For any communication between any of the MEVA II and REDDIG nodes, a sole satellite hop will be utilized, maintaining at the minimum the voice and date communications delay
- Transparent and independent operation for the users of the groups that are not interconnected, no interference on the referred group traffic would take place..
- Being an homogeneous network regarding technology and equipment, the interconnection and interoperability between MEVA II and REDDIG would be implemented without major additional investments in terms of principal equipment or stations.
- Flexibility for the increase of new interconnection users in any of the networks.
- Interoperability principles of regional digital networks are fulfilled.
- Facilitate the implementation of ATN applications.

2.3 As part of the preparatory works to be done within the agreed five-year time, following are the technical-operative considerations identified from previous MEVA REDDIG coordination meetings, such as administrative/institutional aspects discussed:

Considerations and Technical Aspects for the Integration

2.4 The present communications requirement between Regions CAR and SAM, as well as between Regional SAM and NAM, identified for the integration are being presented in **Appendices B** and **C** to this working paper.

2.5 Under network integration concept, MEVA II and REDDIG VSAT networks interoperability in a homogeneous way would be permitted, as if only one VSAT network would be operating, without the need to implement other communications means for the interconnection.

2.6 This interoperability is possible due to technical characteristics of both networks (MEVA II and REDDIG) which are similar: *Full Mesh* network topology, using TDMA/Frame Relay satellite access modality, satellite IS 1R with beam leaded to the United States / Latin America, operation frequency in C band and vertical lineal polarization. In the same way, both networks use similar and compatible equipment, such as those corresponding to FRADS and satellite MODEMs.

2.7 One of the most important parameter for the establishment of an homogeneous MEVA II-REDDIG network is MEVA II and REDDIG carriers synchronization. This synchronization could be done with the MRT (Master Reference Terminal) (based in the ViaSat satellite Linkway MODEM) from the REDDIG NCC or from the MEVA II.

2.8 Due to the importance of the MRT and to avoid that network collapses when this fails, an alternate MRT should be obtained, as the case of the REDDIG. When the MRT fails, the NCC will use the alternate to maintain the network synchronism. This change will be automatic and transparent for the network users. The principal MRT, as well as the alternate, have to be geographically separated and jointed through a direct communication media. The REDDIG MRT (operating in Manaus) and the MEVA II MRT can be considered for MEVA II – REDDIG integration.

2.9 MEVA II and REDDIG networks, being integrated in the same transponder, could operate with various nodes or users groups according to the traffic course between them and to respective frequencies they use. In this way, a group with all the REDDIG nodes could be established, other with all the MEVA II nodes and a third one with all the REDDIG and MEVA II nodes which require voice and data services between them. This third group of users would be formed by the nodes of Colombia, Ecuador and Venezuela (REDDIG) and Araba, Curazao, Panama, Jamaica, Puerto Rico and COCESNA (MEVA II). For synchronization of homogeneous network, only one reference carrier (MRT) would be used. The Architecture and operation for both networks integration are illustrated in diagram 1 and diagram 2 included in **Appendix D** to this working paper.

2.10 In the same way, the following particular premises were identified:

- a) Network Management Centre
 - Equipment redundancy and with hemispheric geographical diversity.
 - Use of MRT and AMRT with geographical diversity to avoid solar interference
 - Dedicated circuit between MRT and AMRT.
 - Operation of the Network Management Centre 24x7x365 in English, Spanish and Portuguese language.
 - Use of carriers of up to 1.25 Msps with QPSK and FEC ½ modulation.
 - Conformation of three group of users: NAM-CAR, SAM and NAM-CAR/SAM.
 - Minimal availability: 99.95%.

- The network is exclusive and closed for State members and it could not be interconnected to none of the public networks.
- b) Remote Nodes
- Desirable that the equipment is redundant.
 - Minimum availability: 99.95%.
 - BER equal or better to 10^{-6} .

Other technical-operational considerations

2.11 Considering the present stage of MEVA II and REDDIG networks interconnection, when the necessary equipment for its implementation is being acquired, and taking into account equipment compatibility and similarity in both networks nodes, it is foreseen that the equipment cost for the integration phase should be minimum since this same equipment would be used..

Considerations and administrative/institutional aspects for the integration

2.12 For the Meeting analysis and evaluation, in **Appendix E** to this working paper, the information that the MEVA II/REDDIG Interconnection Task Force developed on the institutional-administrative aspects for the integration of both networks, which initial approach was the implementation of this integration in two phases: an initial phase and a consolidated phase.

MoU for the MEVA II/REDDIG networks integration

2.13 The Fourth MEVAII REDDIG Coordination Meeting (MR/4) reviewed the draft MEVA II / REDDIG Memorandum of Understanding (MoU) developed by the Second MEVA II / REDDIG Coordination Meeting (MR/02), taking into account revision carried out by the MEVA II/REDDIG Interconnection Task Force, according to Task No. 3 of its work programme ended in November 2006.

2.14 MR/04 Meeting, when reviewing the MoU and taking into account that the mentioned document would be a document revised periodically in order to be analyzed according to the progress of the MEVA II / REDDIG interconnection implementation and to future development of the two networks, agreed that the MoU be initially established in providing essential details of aspects related to the interconnection, since subsequently it would be reviewed to specify integration details in an evolutive manner.

2.15 Therefore, the Meeting should initiate labours to extend or initiate a new MoU for the integration of the MEVA II/REDDIG networks, analyzing technical, administrative and institutional parameters. This activity could be carried out by the MEVA II/REDDIG Interconnection Task Force.

3 Suggested actions

3.1 The meeting is invited to:

- a) take note of the information presented in the working paper,
- b) consider references indicated in paragraphs of section 1 and paragraphs 2.1 to 2.3 in terms of both networks integration benefits,
- c) review and update present and potential requirements referred to in paragraph 2.4 and Appendices B and C to this working paper,
- d) analyze technical operational aspects described in paragraphs 2.5 to 2.11

- e) retake and analyze resulting information on necessary administrative-institutional aspects for the integration of both networks.
- f) consider aspects indicated in paragraphs 2.13 to 2.15 for the extension or elaboration of a new MoU for MEVA II/REDDIG integration
- g) propose and analyze other considerations to continue the preparatory analysis for the integration of the networks.

APPENDIX A

References for Digital Networks Integration

- a) The Third Regional Air Navigation Caribbean and South America Meeting (RAN CAR/SAM/3) (Buenos Aires from October 5th to 15 of 1999) alert GREPECAS the need to develop criterions and pertinent orientation in order to obtain the interconnection among several available and emerging digital networks. Recommendation 9/1 – *Implementation of digital networks to improve present SFA and make easy the ATN introduction.*
- b) In order to set up criterions for digital networks interconnection in a regional an interregional level, two informal meetings: CAR/SAM Informal Meeting 01/00 (Mexico, from June 26 to 29, 2000) and CNS-CAR/SAM Informal Meeting 01/01 (Bogota, Colombia, from October 9 to 11, 2001) were held, as well as MEVA and REDDIG networks Interconnection Coordination Meeting (Lima, from November 11 to 12, 2002). In these meetings several proposals of interconnection alternatives were displayed, including the adoption of an memorandum of understanding for the establishment of an homogeneous digital platform based in MEVA II and REDDIG networks interconnection, as well as the transitory implementation of Colombian network nodes in Jamaica, Panama and COCESNA; it was agreed that these measures be applied until the MEVA II / REDDIG interconnection is obtained.
- c) The GREPECAS/10 Meeting (Las Palmas, Spain, October 23 to 27, 2001) adopted a preliminary orientation material referred to digital networks interconnection for aeronautic communications (Conclusion 10/27). Also, the Conclusion 10/28 indicates the need of capacity provision of massive information exchange through aeronautic communications digital networks.
- d) GREPECAS/12 Meeting (La Habana, Cuba, June 7 to 11, 2004) highlighted the importance to continue efforts in order to achieve interconnection and homogeneous inter-performance among CAR/SAM regional digital networks, considering present and future communication requirements of voice and data and, in this sense, developed Conclusion 12/39 – *Additional inter-connection points for regional and inter-regional digital networks.*
- e) GREPECAS/13 Meeting, based in the recommendation of CNS/COMM/4 Meeting, considered:
 - o the need to continue interconnection/inter-performance efforts between two networks, using, in this respect, the coordination meetings of ICAO Technical Cooperation Projects, related with MEVA II y la REDDIG.
 - o research alternatives, such as implementation of an homogeneous type interconnection or the establishment of interconnection points for a non-homogeneous solution.

- it is important to achieve the purpose of interconnection/inter-performance between MEVA II and REDDIG and consequently, Conclusion 13/70 (implementation of *MEVA II - REDDIG* interconnection/inter-performance agreements) was formulated.

- f) The Fifth Meeting of Group ALLPIRG/Advisory (ALLPIR G/5), held in OACI'S installations, Montreal, Canada, from March 23 to 24, 2006, related to the VSAT networks implementation, formulated the Conclusion 5/16 – *Implementation of small opening terminals (VSAT)*, which deters VSAT networks spread where one or some of the current networks could expand to be able to assume new areas of interest.

APPENDIX B

Table No. 1 – Summary of CAR/SAM interoperability requirements																		
No.	State/Station	ARUBA, Aruba	COLOMBIA Barranquilla	Bogota	Cali	Medellin	San Andrés	ECUADOR, Guayaquil	JAMAICA, Kingston	NETHERLANDS A. Curacao	PANAMÁ, Panamá	PUERTO RICO, San Juan	VENEZUELA Caracas	Josefa Camejo	COCESNA, Tegucigalpa	Total per State		
1	2	3	4	5	6	7	8	9	10	11	12	13	14	15	16	17	18	19
1	ARUBA, Aruba															V		1 Voz
2	COLOMBIA																	8 Voz + 1 Datos
2.1	Barranquilla									V	V	V						
2.2	Bogotá											D,V					V	
2.3	Cali											V						
2.4	Medellin											V						
2.5	San Andrés											V						
3	ECUADOR, Guayaquil																V	1 Voz
4	JAMAICA, Kingston			V														1 Voz
5	NETHERLANDS A. Curacao			V											D,V			2 Voz + 1 Datos
6	PANAMÁ, Panamá			V	D,V	V	V	V										5 Voz + 1 Datos
7	PUERTO RICO, San Juan															D,V		1 Voz + 1 Datos
8	VENEZUELA																	3 Voz + 2 Datos
8.1	Caracas										D,V		D,V					
8.2	Josefa Camejo	V																
9	COCESNA, Tegucigalpa				V				V									2 Voz
	Total per Station	1 Voz	3 Voz	2 Voz + 1 Datos	1 Voz	1 Voz	1 Voz	1 Voz	1 Voz	2 Voz + 1 Datos	5 Voz + 1 Datos	1 Voz + 1 Datos	2 Voz + 2 Datos	1 Voz	2 Voz			

Note: Additionally to requirements expressed in Table No. 1, ATN routers interconnection should be added, as well as new services for the radar data Exchange and other communications services, all of which is in process of revision an definition. .

APPENDIX C

Table No. 2 – Summary of NAM/SAM interoperability requirements		
No.	Communications services	Type
1	2	3
1	Circuito troncal AFTN BRASIL , Brasilia – ESTADOS UNIDOS	Datos
2	Circuito troncal AFTN PERÚ , Lima – ESTADOS UNIDOS	Datos
3	Circuito troncal AFTN VENEZUELA , Caracas – ESTADOS UNIDOS	Datos
4	Interconexión No. 1 de encaminadores ATN (Plan en revisión)	Datos
5	Interconexiones No. 2 de encaminadores ATN (Plan en revisión)	Datos
6	Otros futuros servicios	Datos

APPENDIX D

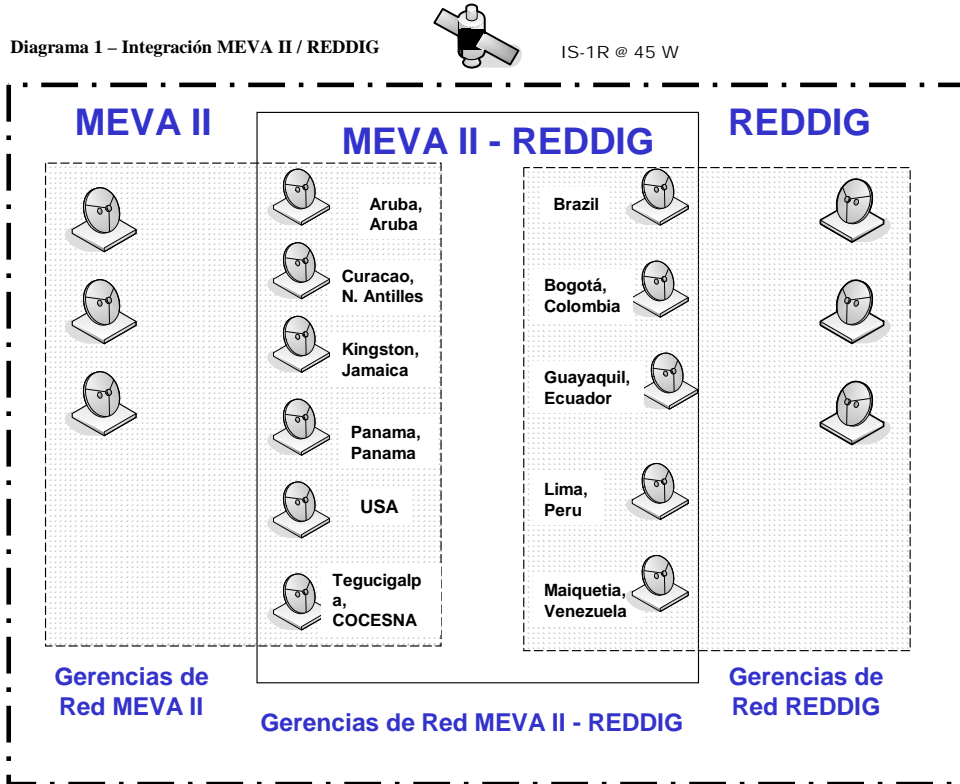

Note: The interrupted dark line represents a total network operator

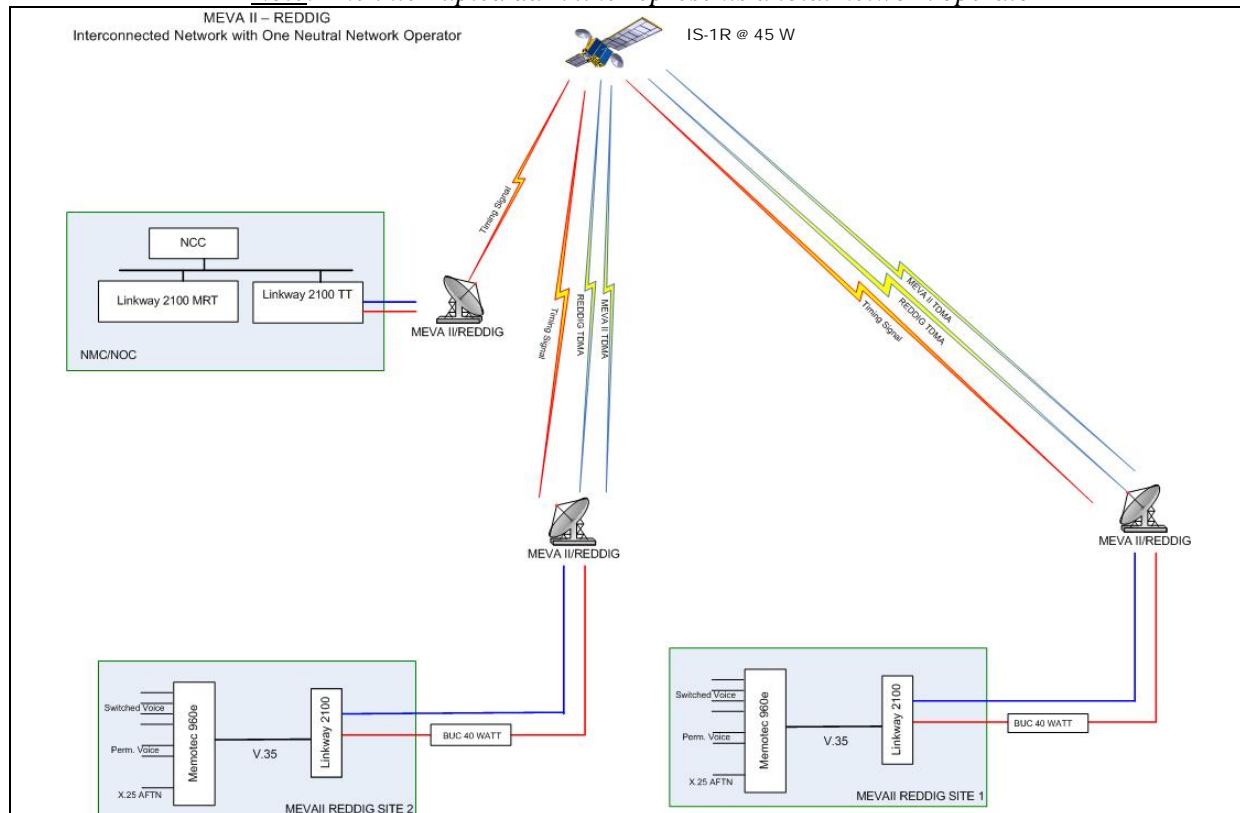

Diagram 2 – MEVA II – REDDIG Networks Interconnected with only one Network Operator

APPENDIX E

Institutional arrangements for the MEVA II and REDDIG VSAT networks integration implementation

The MEVA II/REDDIG Interconnection Task Force in its first meeting (Mexico City, 3-5 May 2006), proposed the adoption of two types of institutional arrangements to achieve the implementation of an integrated-homogeneous network resulting from the integration of VSAT MEVA II and REDDIG networks, which would be implemented in two stages described as follows:

- a) **Initial Stage**: Elaboration of a Memorandum of Understanding (MoU) between REDDIG and MEVA II States, Territories and International Organization, which would be applied during the first of 5 years of the MEVA II Service Provider contracts with the network Members, with the purpose of establishing the different levels of the “Integrated American Network” organization, resulting from the MEVA II / REDDIG integration, as well as the involved responsibilities, maintaining the actual MEVA II and REDDIG service providers.
- b) **Consolidation Stage**: Will consist in the establishment of a Multiregional Organization (OMR), composed by the network’s States, Territories and International Organization, which would hire the operation and outsourcing services of the Telecommunications Integrated Network to one service provider to be agreed.

Applicable arrangements in the Initial Stage

1. The MoU would be established that States, Territories and International Organization Members of the MEVA II and REDDIG to be at the highest level of the Integrated Network as partners, equal in voice and vote. In addition, given the number of Members involved, a Directive Council should be elected. In this manner, work would be carried out in line with GREPECAS, receiving support from this Regional group with the consequent achievement of objectives to which both, VSAT MEVA II and REDDIG were created.
2. The services providers would be at a second level of the Integrated Network, being in this case, the MEVA II Service Provider (AGS) and the REDDIG Administrator, through the Regional project RLA/03/901. The Directive Council would have the option, among other mechanisms to request the ICAO Technical Cooperation Bureau to supervise both providers for the compliance of agreements or other mechanism.
3. At the initial stage, both MEVA II and REDDIG Managements will continue with its respective Service Provider, i.e, REDDIG would keep with RLA/03/901 project and MEVA II with AGS during the complete initial stage. Under this regulatory framework, the Meeting also proposed that a joint agreement should be established between AGS and the REDDIG Administrator under ICAO’s coordination, as regards to the network control, either through the applications of one of the following alternatives:
 - a) One alternation, for a determined period of time, between the main NCC and the alternate NCC.
 - b) The AGS main NCC and the REDDIG alternate NCC.
 - c) The REDDIG main NCC and the AGS alternate NCC.

4. The benefits of both networks should at least maintain themselves or be better, and the costs for the provision of services are equal or less to the current ones for the MEVA II and REDDIG partners. In addition, it is important to take into consideration that the availability of the network is kept for it to have possibility to exchange information between the administrations; in the case of REDDIG, this is ensured through the equipment redundancy and a ground backup network. In the case of MEVA II, the Meeting was informed that the availability is ensured by a specialized service provider which capacity, organization and VSAT networks experience is worldwide recognized.
5. If applicable, the alternation referred in section 3 should be complemented through the establishment of a general agreement between AGS and the MEVA II Members, to define responsibilities when the main NCC is REDDIG's. In a similar manner, an addendum to the REDDIG Project Document would be required to define when the main NCC is MEVA II.
6. During the analysis of alternatives a), b) and c) expressed in afore pa. 3.5, resulting from the Meeting's request, AGS stated the following comments:

Alternative a): Means that AGS and REDDIG overtake the network's management main and alternate responsibilities on or for a pre-determined period. On this AGS declared:

1. AGS cannot overtake or give in the MEVA II administrative or operational supervision due to its SLA. The SLA indicated in the MEVA II RFP, as it is contracted between AGS and the Members stipulates penalties or credits in case that a network or a node remains out of service. This means that AGS should maintain the network and/or its operation management, generally called Network Control Centre, which consists in maintaining the Sun Linkway work stations (main and alternate), the MRT, the AMRT and the NMS to access these systems and the remote nodes ensuring that the general availability is kept.
2. The Network Control Centre or the Network Management Centre (NCC/NMC) for AGS consist also in solving the personnel management and the problems or service interruptions reports. The timely solution by the personnel also affects the SLA.

Alternative b): Means the Network Control Centre or the Network Management Centre (NCC/NMC) main in AGS and the REDDIG alternate in NCC. In this respect AGS declared:

1. From a supportive point of view this is possible. This means that REDDIG could be the alternate NCC/NMC and assist the REDDIG nodes problems and only in emergency situations take control of the network operations.
2. For AGS the Network Control Centre or the Network Management Centre (NCC/NMC) consist in personnel management and to solve the failure reports or "service outage". The timely solution of failures from the personnel also impacts the SLA. The REDDIG Members could have more knowledge and control on the configuration and operation of its nodes, since they own them and AGS will not be responsible of the availability of those equipments.

Alternative c): Means that the main NCC in REDDIG and the alternate in AGS. In this respect AGS declared:

1. This is not an option for the same reason discussed in Alternative a), paragraphs 1 and 2.

7. Also, the Meeting took note of the information presented by the United States, which overviews the FAA security requirements requested the MEVA II Service Provider to fulfill. Additionally, the Meeting noted that if the REDDIG Administration assumes certain responsibilities in respect to the MEVA II network, would also have to comply with the FAA's requirements for this network.

Consolidation Stage applicable arrangements

1. Once finalized the MEVA II first contract with AGS fixed for a 5 year period is finalized, it would pass to the Consolidation Stage consisting in the creation of a Multiregional Organization (OMR), to hire the telecommunications integrated network operation services and “outsourcing” to only one services provider entity. Likewise, the OMR would coordinate the planning and development of aeronautical communication services in the regions, as well as the respective implementations and the telecommunication integrated network as the platform.
2. Also, during this consolidation stage, the OMR would supervise the compliance of the “Service Level Agreement” (SLA) with the services provider entity.