



Agenda Item 1: Follow up of the Action Plan for the MEVA II/REDDIG interconnection implementation

FOLLOW UP OF THE MEVA II REDDIG ACTION PLAN

(Presented by the Secretariat)

SUMMARY

This working paper presents the activities carried out for the MEVA II REDDIG interconnection implementation based on MEVA II REDDIG Action Plan attended during the Fifth MEVA II REDDIG Coordination Meeting, held in Mexico City, from 3 to 5 October 2007.

References

- Report of the Fifth MEVA II REDDIG Coordination Meeting (Mexico City, 3-5 October 2007)
- Report of GREPECAS/14 Meeting

1 Background

1.1 GREPECAS 14 Meeting, held in San José, Costa Rica, from 16 to 20 April 2007, after reviewing the state of progress and integration/interconnection of VSAT networks MEVA II and REDDIG and after being informed of the actions being carried out by States, Territories and International Organizations members of these networks, formulated Conclusion 14/52 (*Review for the adoption of the memorandum of understanding and implementation of the action plan for the MEVA II / REDDIG interconnection*) through which States/Territories/International Organizations members of VSAT networks MEVA II and REDDIG are urged to approve and execute their corresponding duties indicated in the Action Plan for the interconnection implementation, elaborated during the Fourth MEVA II/REDDIG Coordination Meeting (MR/4), held in Lima, Peru, from 7 to 9 March 2007.

1.2 The Fifth MEVA II/REDDIG Coordination Meeting (MR/05) when analyzing progress of the MEVA II/REDDIG interconnection implementation Action Plan execution, of the RFP process, of the MoU revision by the members of MEVA II and REDDIG networks, and taking into account responses presented to the RFP by MEVA II Service Supplier and REDDIG Administration, updated the provisional MEVA II and REDDIG VSAT network interconnection implementation Action Plan.

1.3 The MR/5, in order to carry out the implementation activities foreseen in the action plan in a coordinated manner, the Meeting agreed that the parties involved in the execution of this Plan should name a point-of-contact to coordinate the activities related to the MEVA II / REDDIG interconnection with the MEVA II Service Provider and the REDDIG Administration.

1.4 The MR/5 considered that many of the activities proposed in the action plan could be executed simultaneously on behalf of the MEVA II and REDDIG members. Among these activities are the review and approval of the Technical-Economical Proposal, the review and approval of the MoU as a consequence of the amendments made to the document, as well as the review and approval of the contracts that will allow the acquisition and implementation of the equipment for the interconnection.

1.5 With the purpose of allowing the REDDIG Administration to proceed with the analysis to agree on a contract with the MEVA II Service Provider, the Meeting requested the Provider to submit a contract for analysis. Regarding this issue, the Meeting considered including an activity related to the signing of the contract on behalf of States, Territories and International Organization involved in the MEVA II / REDDIG interconnection with the MEVA II Service Provider or with the REDDIG Administration.

1.6 The Meeting urged the members of the MEVA II and REDDIG Networks, the MEVA II Service Provider and the REDDIG Administration to proceed with the implementation of the established actions on the scheduled dates in order to achieve interconnection implementation in May 2008.

2 Analysis

2.1 Activities carried out since the Fifth MEVAII/REDDIG Coordination Meeting are being described below:

Response to the RFP

2.2 The MEVA II Service Supplier presented during the MR/5 his response to the RFP in two volumes, Volume I where the technical proposal for MEVA II/REDDIG interconnection implementation is being presented, and Volume II that contains the economical proposal to implement the interconnection.

2.3 The MR/5 Meeting when analyzing the response to the RFP by the MEVA II Service Supplier, considered that this presented in a detail way all the aspects required to implement MEVA II/REDDIG interconnection.

2.4 However, MR/5 Meeting considered that the response to the RFP needed a revision regarding some technical and economical aspects, formulating in this respect Conclusion MR 5/1 (*Review of the Response from the MEVA II Service Provider to the MEVA II / REDDIG RFP*) in which MEVA II supplier was being requested to forward to the ICAO Mexico Regional Office the revision to the RFP before 19 October 2007.

2.5 RFP response revision was sent in November 2007 to ICAO Mexico Regional Office, which is being presented as **Appendix A** to this working paper. In the revised response, it can be observed that it is not included if Venezuela node requires an amplifier with more power.

2.6 The MR/5 also reviewed the REDDIG Administration response to the RFP, comments to this response were formulated during the MR/05 Meeting.

Focal points nomination

2.7 ICAO Mexico and Lima Regional Offices sent a letter to States/Organization members of the MEVA II and REDDIG involved in the interconnection, in order to nominate a focal point. The focal points list is presented in the **Appendix B** to this working paper.

Application of the revised MoU

2.8 The MR/5 recalled that the GREPECAS/14 Meeting, held in San José, Costa Rica from 16 to 20 April 2007, reviewed the development and integration/interconnection status of both regional networks, and drafted Conclusion 14/52 – *Review for the Adoption of the Memorandum of Understanding and Implementation of the Action Plan for the MEVA II / REDDIG Interconnection*, through which, among other aspects, urged MEVA II / REDDIG member Administrations to “study and review the feasibility to adopt the Memorandum of Understanding (MoU).”

2.9 Taking into account the proposals for amendment to the MoU received by the Regional Offices, the MR/5 adopted the revised MoU. The changes made to the MoU have been made only to specify the solution for implementation of the MEVA II / REDDIG interconnection, as well as any aspects relevant to the form of doing so. The integration agreements are contemplated to be carried out by the end of the interconnection. It is considered that the essential technical-administrative content of the initial MoU version, which represents the main purpose of the document, has remained without major changes.

2.10 The MR/5 agreed that the revised version of the MoU, which was adopted by this Meeting, should be re-circulated. Members are urged to sign the revised version of the MoU, formulating Conclusion MR 5/3 (*Adoption of the revised MoU for the MEVA II / REDDIG interconnection*). Since the MoU revised version remission, no ICAO Office has received objections nor comment to the referred document; presently States/Territories/Organization members of the MEVA II REDDIG that have signed the MoU are Argentina , Brazil, Chile, Cuba, COCESNA, Guyana, Peru, United States and Uruguay.

Review of and agreement with MEVA II/REDDIG interconnection costs

2.11 ICAO Lima and Mexico Regional Offices did not receive comments from States/Territories/Organization members of the REDDIG and MEVA II regarding MEVA II Service Supplier’s and REDDIG Administration proposed prices, therefore it was considered that there was agreement with referred prices.

AGS Contract revision and signature by the REDDIG Administration

2.12 The MR/5 formulated Conclusion MR 5/5 (*Request for a Contract Proposal Between the MEVA II Service Provider and the REDDIG Administration*) in order that MEVA II Supplier provide a contract form with the purpose that the REDDIG Administration be able to review it for its signature to continue with the interconnection implementation process.

2.13 MEVA II service supplier sent the contract form to the Mexico Regional Office at the beginning of November 2007. This was forwarded to ICAO Montreal Technical Cooperation Bureau at the beginning of December 2007. The revision of the contract by the Technical Cooperation Bureau has been considerably delayed in spite of the various letters that the REDDIG Administration has sent in order to expedite contract analysis and signature. In this regard, it is worth to point out that TCB indicated that, to follow with purchasing procedures, MEVA II and REDDIG interconnection should be done through a bidding process within different companies of the market, and that the contract could not be assigned directly to a firm. In this regard, the Technical Cooperation Bureau informed that they will proceed to a bid process which will have a duration of approximately two months since the date of reception of the letter (18 April 2008).

2.14 To supply the service, TCB considered to address to the MEVA II service supplier since due to particular characteristics of the MEVA II/REDDIG interconnection this can only be implemented by the MEVA II supplier. In this regard, the MEVA II service supplier was requested to modify the contract format in order to include, only, recurrent services (voice and data services) and to revise the economical proposal.

2.15 As a consequence of the delays in the signature of the contract with AGS, dates of the action plan work programme approved during the Fifth MEVA II/REDDIG Coordination Meeting have been updated, which is attached as **Appendix C** to this working paper.

2.16 Based on the execution of activities and as follow up of conclusions of the last coordination meeting still in force, in **Appendix D** to this working paper the proposal for their update is being presented.

3 Suggested actions

3.1 The Meeting is invited to:

- a) Take note of information being presented;
- b) analyze the activities carried out for the MEVA II/REDDIG interconnection indicated in section 2 of this working paper, including Appendices A, B and C to this working paper, and carry out the necessary actions for decision making in order to be able to continue with the MEVA II/REDDIG interconnection implementation;
- c) analyze other issues related with this agenda that the Meeting considers convenient.

October 19, 2007

To: ICAO – NACC and SAM Offices
Subject: MEVA II – REDDIG Interconnection

Dear Member States,

As both MEVA II and REDDIG networks look to the future of Interconnection, the satellite services provider must offer advanced, and steadfast, consolidated services. The goal of AMERICOM GOVERNMENT SERVICES (AGS) is to respond efficiently and precisely to MEVA II and REDDIG's requirements while creating a flexible framework for meeting future requirements. We can achieve this goal because we have an understanding of both networks as well as their future strategic direction. Aligning AGS' goals and strategies with those of MEVA II and REDDIG, AGS can create a partnership dedicated to mutual success. AGS is fully capable of helping the member states of both networks obtain leading satellite services and satellite technology.

The physical site locations of air traffic control facilities to be interconnected:

- Aruba
- Venezuela
- Colombia
- Brazil
- Peru
- Netherlands Antilles, Curacao
- USA, Puerto Rico, San Juan
- Guayaquil, Ecuador
- Jamaica, Kingston
- USA, Miami, FL
- Panama, Panama
- COCESNA, Honduras, Tegucigalpa

By issuing the RFP, the ICAO NACC and SAM Offices seek to interconnect specific MEVA II and REDDIG nodes and award a service contract that will expire on the 5-year anniversary date of the MEVA II contract.

In Volume I – Technical and Volume II – Pricing, AGS provides a complete and detailed proposal for achieving the interconnection requirements according to their present equipment expertise, i.e. MEVA II equipment with Americom Government Services (AGS) and REDDIG with the REDDIG Administrator, including equipment and services as well as any consideration/condition for its installation and operation.

The Interconnection requirements and specifications are part of a whole process of integration of networks, in which after a five-year period from 2006, both MEVA II and REDDIG networks are to be integrated in a single network with a primary and a secondary operational centers.

AMERICOM Government Services greatly appreciates the opportunity to provide the following solution for the interconnection of the MEVA II and REDDIG VSAT Telecommunication Networks.

Best regards,

Dave B.

David J. Benning
Director, Civil and Intel Sales
AMERICOM Government Services, Inc.
Email: david.benning@americom-gs.com
Tel: 1.703.917.5608
Mobile: 1.571.332.0761
www.americom-gs.com

Volume I – Technical Table of Contents

1.0 EXECUTIVE SUMMARY3

2.0 PROGRAM MANAGEMENT APPROACH *RFP 1.7.1*.....5

3.0 TECHNICAL SOLUTION.....6

3.1 TECHNICAL APPROACH.....6

 3.1.1 INTRODUCTION *RFP 1.7.1, 2.1.1, 2.1.2, 2.1.2.4* 6

 3.1.2 EQUIPMENT AND CIRCUIT REQUIREMENTS 7

 3.1.2.1 CIRCUIT REQUIREMENTS *RFP 2.2.1*..... 7

 3.1.2.2 EQUIPMENT REQUIREMENTS *RFP 1.7.1, APP B, APP C, 2.2.1* 8

 3.1.3 LINK BUDGET *RFP 2.1.2* 10

 3.1.4 INDOOR UNIT (IDU) REQUIREMENTS *RFP 2.1.2.1*..... 11

 3.1.5 OUTDOOR UNIT (ODU) REQUIREMENTS *RFP 2.1.2.2*..... 12

 3.1.6 MEVA II / REDDIG ANTENNA SYSTEM *RFP 2.1.2.3*..... 12

 3.1.7 DESIRED SPACE SEGMENT ARCHITECTURE *RFP 2.1.2.5*..... 12

 3.1.8 REMOTE VSAT SITE & TERMINAL ADDRESSING *RFP 2.1.2.6*..... 12

 3.1.9 ACQUISITION & SYNCHRONIZATION *RFP 2.1.2.7, APP A*..... 12

 3.1.10 CLOCK MANAGEMENT *RFP 2.1.2.8*..... 13

 3.1.11 NETWORK MANAGEMENT REQUIREMENTS *RFP 2.1.2.9, APP A* 13

 3.1.12 INTERNET PROTOCOL (IP) SERVICES *RFP APP A*..... 13

 3.1.13 FRAME RELAY (FR) SERVICE *RFP APP A*..... 13

 3.1.14 FRAME RELAY SERVICE PROVISIONING *RFP APP A* 14

 3.1.15 CONSIDERATIONS OF MEVA II AND REDDIG NCC/NMS: *RFP 2.1.2.4*..... 14

 3.1.16 SYSTEM SOFTWARE *RFP 2.5.2* 15

3.2 IMPLEMENTATION PLAN *RFP 2.3.1*.....15

 3.2.1 NETWORK PREPARATIONS 15

 3.2.2 SITE SURVEY 15

 3.2.3 PROCUREMENT 16

 3.2.4 CIVIL WORKS 16

 3.2.5 LICENSING 16

 3.2.6 CONFIGURATION, INTEGRATION, AND TESTING *RFP 2.4*..... 16

 3.2.7 SHIPPING..... 16

 3.2.8 INSTALLATION AND TESTING *RFP 2.4*..... 16

 3.2.9 TECHNICAL DOCUMENTATION *RFP 2.5.1*..... 17

3.3 OPERATIONS AND MAINTENANCE ACTIVITIES17

 3.3.1 NETWORK CONTROL CENTER (NCC) 17

 3.3.1.1 REDDIG NCC RESPONSIBILITIES *RFP 2.1.2.4*..... 17

 3.3.1.2 MEVA II NCC RESPONSIBILITIES *RFP 2.1.2.4*..... 17

 3.3.1.3 ADMINISTRATIVE COORDINATION BETWEEN AGS AND REDDIG
 ADMINISTRATOR: *RFP 2.1.2.4* 18

 3.3.1.4 NCC SECURITY *RFP 2.1.2.4*..... 18

 3.3.1.5 NETWORK AND LINK LEVEL PERFORMANCE MONITORING *RFP APP A*..... 19

CONFIDENTIAL

Use, duplication and disclosure of the information contained on this page is subject to the restrictions contained in the CONFIDENTIAL NOTICE on the title (first) page of this proposal.

3.3.2 TECHNICAL OPERATIONS CENTER (TOC) <i>RFP 2.1.2.4</i>	20
3.3.2.1 NETWORK SECURITY MANAGEMENT <i>RFP APP A</i>	21
3.3.3 PLAN FOR MAINTENANCE, REPAIR AND REPLACEMENT OF EXISTING EQUIPMENT	21
3.3.3.1 SPARES <i>RFP 2.3.1</i>	21
3.3.3.2 ON-SITE MAINTENANCE	21
3.3.3.3 REPAIRS AND REPLACEMENTS <i>RFP 2.3.2</i>	21
3.3.4 PLAN FOR ROUTINE EQUIPMENT MAINTENANCE AND EMERGENCY REPAIRS <i>RFP 2.3.3</i>	22
3.3.5 SCHEDULED MAINTENANCE NOTIFICATION	22
3.3.6 TRANSPONDER FAILURE	22
3.3.7 SERVICE PROVIDER INITIATED NETWORK CHANGES.....	22
3.3.7.1 CHANGE NOTIFICATIONS <i>RFP 2.6.1</i>	23
3.3.8 ACTIVATION OF NEW SERVICES <i>RFP 2.7</i>	23
3.3.9 DISCONTINUATION OF SERVICE <i>RFP 2.8</i>	23
3.3.10 REPORTS <i>RFP 2.1.2</i>	23
3.3.11 MEVA II / REDDIG PROGRAM ADMINISTRATION <i>RFP 2.9</i>	23
3.4 SYSTEM PERFORMANCE	24
3.4.1 SATELLITE LINK AVAILABILITY <i>RFP APP A</i>	24
3.4.2 SWITCHED VOICE CIRCUIT CALL BLOCKING PERFORMANCE <i>RFP APP A</i>	24
3.4.3 DATA CIRCUIT LATENCY PERFORMANCE <i>RFP APP A</i>	24
3.4.4 QUALITY OF SERVICE (QOS) PARAMETERS <i>RFP 2.3.1</i>	25
<i>Specification</i>	25
3.4.5 CREDIT COMPUTATION <i>RFP 2.3.1</i>	25
3.4.6 NON-COMPLIANCE.....	26
4.0 APPENDIX 1F (ICAO)	27
TABLE 1: THE AGS INTERCONNECTION PROGRAM PLAN	5
TABLE 2: INTERCONNECTION CIRCUIT REQUIREMENTS	8
TABLE 3: INTERCONNECTION EQUIPMENT REQUIREMENTS	10
TABLE 4: ITU AND ANSI STANDARDS	14
TABLE 5: INTERCONNECTION TOC ESCALATION LEVELS.....	21
TABLE 6: INTERCONNECTION QOS PARAMETERS	25
Attachment A: Link Budgets	
Attachment B: Block Diagrams	
Attachment C: AGS Program Management – Gantt Charts	
Attachment D: Technical Documentation for Terrasat BUC and Switch	
Attachment E: SES AMERICOM Woodbine Teleport	
Attachment F: MEVA II Advanced Technician Training Guide	

CONFIDENTIAL

Use, duplication and disclosure of the information contained on this page is subject to the restrictions contained in the CONFIDENTIAL NOTICE on the title (first) page of this proposal.

1.0 Executive Summary

The REDDIG and MEVA II networks both provide communications critical to air traffic safety in the South American, Caribbean, and Central American operating regions. Each member state, brought together by the International Civil Aviation Organization (ICAO), is networked to provide voice (switched, hotline, and administrative) and data (flight plans) that are used to help ensure the safety of thousands of commercial flights each year. Currently, these two networks are separate and cannot be used to inter-communicate as flights pass between the Caribbean and Central American region and the South American region.

Although the two networks are currently separate entities, they are designed so that an individual node may be added into either network with additional hardware and configuration.

MEVA II and REDDIG members defined the requirement for the interconnection of circuits between designated MEVA II nodes and designated nodes in the REDDIG VSAT network.

The AGS MEVA - REDDIG Interconnection solution minimizes the amount of integration necessary to accomplish this goal by using the same frame relay device that breaks out the individual voice or data circuit required for both networks.

Our technical solution, which places particular emphasis on the availability and reliability performance factors, is designed under the following premises:

- REDDIG and MEVA II VSAT Interconnection Network will both operate under a full-mesh network topology, using TDMA/Frame Relay satellite access, employing a IS-IR satellite transponder with a beam directed over United States /Latin America, C-Band operational frequencies and co-linear vertical polarization.
- Installation of MEVA II compatible modems in the REDDIG nodes in Bogotá, Colombia and Caracas, Venezuela, and a REDDIG compatible modem in the MEVA II node in COCESNA using the existing FRADS allowing communications from any MEVA II site to Bogotá and Caracas and from any REDDIG site to COCESNA.
- For all new equipment to meet the service requirements of our solution, AGS will use only commercial-off-the-shelf (COTS) equipment and/or software from reputable manufacturers and suppliers.
- Our design for the MEVA II / REDDIG Interconnection solution is modular and technologically upgradeable, state of the art, compatible with existing modules in the existing VSAT nodes, thereby permitting a high degree of flexibility for implementing future changes in communications services when requested to do so by ICAO.

CONFIDENTIAL

Use, duplication and disclosure of the information contained on this page is subject to the restrictions contained in the CONFIDENTIAL NOTICE on the title (first) page of this proposal.

Taking the above requirements into full consideration, our proposal addresses in detail how we will meet the following key requirements:

- Implement a MEVA II / REDDIG Interconnection solution that is capable of using a wide variety of standard information protocols such as X.25, IP, Frame Relay, and circuit switching protocols for future ATN support.
- Provide each MEVA II / REDDIG end-user with a written monthly report showing the end-user's individual bandwidth usage, call record details, system performance statistics, and a trouble log summary (e.g., trouble ticket number, transaction date/time, trouble reported, cause and repair, and technician name at both ends), as well as the same service being now provided in the MEVA II Network or in the same level as is being provided in the REDDIG Network.
- AGS will maintain an online database, which will include current network status, call record list, call statistics, and trouble report list, which may be accessible by the user. The user will be permitted read only, password access to the NCC via an optional NMS located at each customer site.

Also included in our technical proposal is the following essential documentation for successful implementation:

- Attachment A: Link Budgets
- Attachment B: Block Diagrams
- Attachment C: AGS Program Management – Gantt Charts
- Attachment D: Technical Documentation for Terrasat BUC and Switch
- Attachment E: SES AMERICOM Woodbine Teleport
- Attachment F: MEVA II Advanced Technician Training Guide
- Appendix 1F (ICAO) with AGS responses inserted

CONFIDENTIAL

Use, duplication and disclosure of the information contained on this page is subject to the restrictions contained in the CONFIDENTIAL NOTICE on the title (first) page of this proposal.

2.0 Program Management Approach *RFP 1.7.1*

AGS uses industry standard practices to manage the implementation of satellite networks from start to finish. This Life Cycle Management approach is divided into four phases. In the *Initiation Phase*, the basis for program is established through management and engineering reviews of the RFP and proposal response. In the *Planning Phase*, The Program Plan is finalized and submitted for review and approval by AGS and the customer. The Program Plan is the road map to a successful implementation. This plan includes the following:

Executive Summary	Summary of the Program Plan and the goals it is intended to accomplish
Program Charter	Identifies the assigned Program Manager and defines the PM's authority in the program implementation
Program Team	Identifies AGS' core team members and their roles and responsibilities
Customer SOW	Copy of the RFP SOW
Proposed Solution	Summary of AGS' proposal response identifying deliverables
MS Project Schedule	Used to plan and track, tasks, timelines, and resource allocation
Communications Plan	Lists contact information of AGS team, key customer and vendor contacts to include their primary roles. This document also establishes periodic and milestone meetings and reports throughout the Program implementation life cycle
Risk Assessment and Mitigation Strategy	Used to identify issues that may pose a risk to implementation that affects, time, scope, or cost. It also lists steps to be taken to mitigate the stated risks
Subcontract Management Plan	Used to by AGS to establish plan for dealing with subcontractors, to include reporting requirements, and SOW template
Change Management Plan	Establishes a procedure to effect a change in the scope, timeline, and/or cost of the Program implementation. Provides a form that lists the proposed change, initiates reviews by both AGS and customer representatives to assess impact, and AGS and customer approvals
Report Templates	Templates of reports to be used during program implementation
Closedown Procedures	Procedures for AGS to transition from implementation to Operations and Maintenance. Also provides for AGS to perform a lessons-learned session to identify areas for improvement for future implementations

Table 1: The AGS Interconnection Program Plan

The *Execution Phase* puts the Program Plan into action. Actions include integration, installation, and testing of systems. Finally, the *Closedown Phase* includes transition from implementation to Operations and Maintenance and final customer acceptance.

Periodic reviews are held throughout the Program Life Cycle to track current status and identify and address existing or potential issues. Through this management approach, AGS establishes documented, repeatable actions that promote quality control and good business practices.

CONFIDENTIAL

Use, duplication and disclosure of the information contained on this page is subject to the restrictions contained in the CONFIDENTIAL NOTICE on the title (first) page of this proposal.

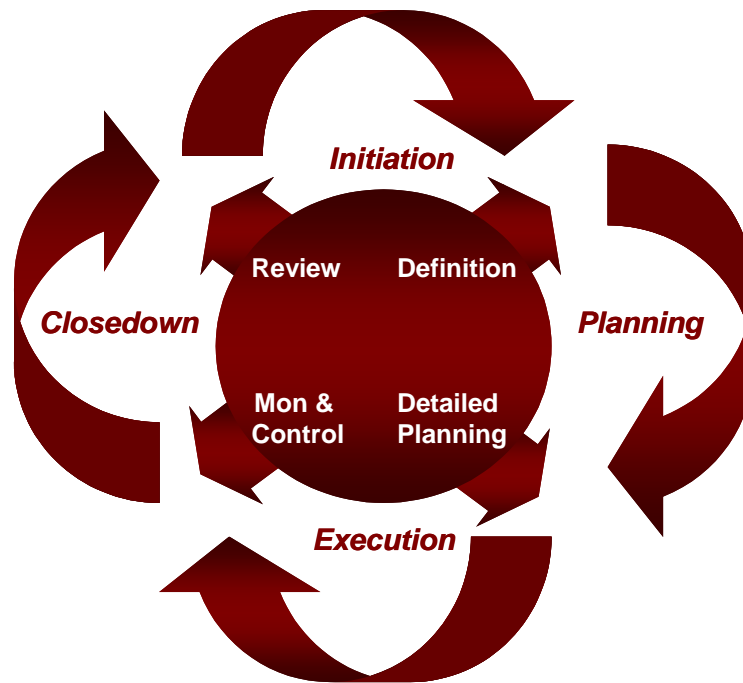

Program Life Cycle Management

Figure 1: Program Life Cycle Management

3.0 Technical Solution

3.1 Technical Approach

3.1.1 Introduction *RFP 1.7.1, 2.1.1, 2.1.2, 2.1.2.4*

The REDDIG and MEVA II networks both provide communications critical to air traffic safety in the South American, Caribbean, and Central American operating regions. Each member state, brought together by the International Civil Aviation Organization (ICAO), is networked to provide voice (switched, hotline, and administrative) and data (flight plans) that are used to help ensure the safety of thousands of commercial flights each year. Currently, these two networks are separate and cannot be used to inter-communicate as flights pass between the Caribbean and Central American region and the South American region.

Although the two networks are currently separate entities, they are designed so that an individual site may be added into either network with additional hardware and configuration. The Americom Government Services (AGS) Interconnect solution is modular and state-of-the-art, compatible with existing equipment in both networks, and flexible in its architecture.

CONFIDENTIAL

Use, duplication and disclosure of the information contained on this page is subject to the restrictions contained in the CONFIDENTIAL NOTICE on the title (first) page of this proposal.

All components used in the AGS solution are commercial-off-the-shelf (COTS) equipment.

The AGS solution will interconnect the REDDIG and MEVA II networks, using the existing VSAT antennas at the following three locations:

- Bogotá, Colombia
- Caracas, Venezuela
- Tegucigalpa, Honduras (COCESNA/Cenamer)

The Interconnect solution will extend the MEVA II network into Bogotá, Colombia and Caracas, Venezuela while extending the REDDIG network into COCESNA/Cenamer. The Interconnect locations will be on both the MEVA II and REDDIG networks and will be tied together using the existing FRADS allowing communications from any MEVA II site to Bogotá and Caracas and from any REDDIG site to COCESNA/Cenamer.

The MEVA II / REDDIG Interconnection solution will use the Viasat LinkWay 2100 modem that supports a broad range of communications protocols, including X.25, IP, Frame Relay as well as circuit switching protocols. ATM functionality is no longer supported by ViaSat, the Linkway manufacturer and is therefore no longer listed as an available protocol. The LinkWay platform allows the end user to share bandwidth across multiple sites in a mesh or hybrid network configuration. The Bandwidth-On-Demand (BOD) system allows flexibility to assign bandwidth on a dynamic basis, for less critical services, or permanent basis for those communications services that are mission critical. The BOD system allows the user better utilization of the bandwidth while providing multiple protocols for various types of traffic, i.e. Frame Relay, or IP for voice, data or imagery.

3.1.2 Equipment and Circuit Requirements

3.1.2.1 Circuit Requirements *RFP 2.2.1*

The following frame-relay circuits in Table 3.1.2.1 (per Appendix B of the RFP) will be configured on the AGS NCC and will use bandwidth from the MEVA II pool. AGS will provide the bootfiles for the Linkway 2100’s at Colombia and Venezuela. The REDDIG Administrator will provide the boot file for the Linkway 2100 at COCESNA. AGS and the REDDIG Administrator will work together on the Memotec configurations.

Location	Frame-Relay Circuit	Quantity
From Caracas to:		
Curacao	Switched Voice Duplex 16K Bandwidth-on-Demand PVC	1
	One AFTN Data Duplex 2.4K Bandwidth-on-Demand PVC	1

CONFIDENTIAL

Use, duplication and disclosure of the information contained on this page is subject to the restrictions contained in the CONFIDENTIAL NOTICE on the title (first) page of this proposal.

Location	Frame-Relay Circuit	Quantity
Aruba	Switched Voice Duplex 16K Bandwidth-on-Demand PVC	1
Puerto Rico	Switched Voice Duplex 16K Bandwidth-on-Demand PVC	1
	AFTN Data Duplex 2.4K Bandwidth-on-Demand PVC	1
From Bogotá to:		
Curacao	Switched Voice Duplex 16K Bandwidth-on-Demand PVC	1
Jamaica	Switched Voice Duplex 16K Bandwidth-on-Demand PVC	1
Panama	Switched Voice Duplex 16K Bandwidth-on-Demand PVC	2
	AFTN Data Duplex 2.4K Bandwidth-on-Demand PVC	1
	Always-on Voice Hotline Duplex 16K	1
COCESNA	Switched Voice Duplex 16K Bandwidth-on-Demand PVC	1
Miami	AFTN Data Duplex 2.4K Bandwidth-on-Demand PVC	2
Location	Frame-Relay Circuit	Quantity
From COCESNA to:		
Ecuador	Switched Voice Duplex 16K Bandwidth-on-Demand PVC	1
Bogotá	Switched Voice Duplex 16K Bandwidth-on-Demand PVC	1

Table 2: Interconnection Circuit Requirements

3.1.2.2 Equipment Requirements *RFP 1.7.1, App B, App C, 2.2.1*

Table 3.1.2.2 lists additional equipment and parts needed (per Appendix C of the RFP) at each location to provide interconnection communications between the MEVA II and REDDIG networks. REDDIG sites use 1:1 redundancy. Therefore AGS has taken this into consideration when assessing required equipment.

Location	Additional Equipment/Parts Needed	Quantity
COCESNA	Linkway 2100 with frame-relay card and V.35 cable	1
	Memotec DAV Card	1
	Memotec FXS SLIM LID	2
	Memotec V.35H Card	1

CONFIDENTIAL

Use, duplication and disclosure of the information contained on this page is subject to the restrictions contained in the CONFIDENTIAL NOTICE on the title (first) page of this proposal.

Location	Additional Equipment/Parts Needed	Quantity
	2-port L-band Splitter	1
	2-port L-band Combiner	1
Curacao	Memotec DAV Card	1
	Memotec FXS SLIM LID	1
	Memotec V.24 Card	1
Caracas	Linkway 2100 with frame-relay card and V.35 cable (AGS strongly recommends two modems for both sites to match REDDIG's existing redundant network setup.)	1
	Memotec DAV Card (2 for MUX A, 2 for MUX B)	4
	Memotec FXS SLIM LID (3 for MUX A, 3 for MUX B)	6
	2-port L-band Splitter	1
	2-port L-band Combiner	1
	Memotec configuration assumes existing V.24 ports or Universal ports will be used to satisfy (2) AFTN circuit requirement and existing Universal port will be used to satisfy V.35 Linkway interface requirement	
Bogotá	Linkway 2100 with frame-relay card and V.35 cable (AGS strongly recommends two modems for both sites to match REDDIG's existing redundant network setup.)	1
	Memotec E-1 Daughter Card (1) for MPS A, (1) for MPS B to be installed in slot 2	2
	2-port L-band Splitter	1
	2-port L-band Combiner	1
	Memotec configuration assumes existing multi V.24 ports or Universal ports will be used to satisfy (3) AFTN circuit requirement and existing Universal port will be used to satisfy V.35 Linkway interface requirement	
Jamaica	Memotec DAV Card	1
	Memotec FXS SLIM LID	1

CONFIDENTIAL

Use, duplication and disclosure of the information contained on this page is subject to the restrictions contained in the CONFIDENTIAL NOTICE on the title (first) page of this proposal.

Location	Additional Equipment/Parts Needed	Quantity
Miami	Memotec 960e Chassis	1
	Memotec 960e CPU	1
	Memotec 960e Power Supply	1
	Universal I/O	1
Panama	Memotec DAV Card	1
	Memotec E&M SLIM LID	0
	Memotec FXS SLIM LID	2
	Memotec Multi I/O card	1
San Juan	Memotec DAV Card	1
	Memotec FXS SLIM LID	1
	Memotec Multi I/O card	1
Ecuador	E-1 Daughter Card for Memotec A and Memotec B	2

Table 3: Interconnection Equipment Requirements

Our original proposal assumed that REDDIG technical staff would install the necessary equipment in Peru and Brazil to connect these AFTN circuits. With this modification AGS assumes that REDDIG will also supply the necessary equipment at these sites for the interconnection of the two networks. AGS will assume no responsibility for equipment procured and installed by REDDIG for Peru and Brazil.

3.1.3 Link Budget *RFP 2.1.2*

Attachment A includes the Satellite Link Budget Performance Analysis for the interconnection nodes and their associated connection requirements in a vertical co-pol C-band configuration on the IS-1R satellite (previously known as PAS-1R). Implementation of the Interconnect solution is contingent upon MEVA II's authorization to transition the MEVA II network to Vertical Co-Pol. AGS has presented a Rough order of Magnitude through ICAO Mexico and is awaiting response.

CONFIDENTIAL

Use, duplication and disclosure of the information contained on this page is subject to the restrictions contained in the CONFIDENTIAL NOTICE on the title (first) page of this proposal.

3.1.4 Indoor Unit (IDU) Requirements *RFP 2.1.2.1*

AGS understands the requirement for minimizing the amount of indoor equipment to be installed to successfully implement the interconnection between MEVA II and REDDIG. AGS will use the sites' existing Memotec Frame Relay Device (FRAD) and connect to a newly installed Linkway 2100 satellite modem that is dedicated to the interconnected network (MEVA II for Colombia and Venezuela and REDDIG for COCESNA). Each Linkway is L Band-based, which allows AGS to tie into the sites' existing Inter-Facility Link (IFL) with the use of Splitters / Combiners. As to the Memotec configuration, the following assumptions have been made regarding the Interconnect sites:

Venezuela – Based on Venezuela's circuit requirement of (3) ATS voice circuits and (2) AFTN circuits and card requirement of (4) Dual Analog Voice (DAV) cards (reference RFP Appendix B and C), AGS assumes that (2) of the DAV cards are intended for a MUX A empty slot and (2) for a MUX B empty slot, thereby providing redundant paths. AGS also assumes that since there is no requirement for V.24, Multi I/O, or Universal I/O cards, that existing cards have available ports to accommodate a V.35 interface to the MEVA II Linkway and (2) V.24 ports (from existing Multi I/O or Universal I/O) for the needed AFTN circuits.

Colombia - Based on Colombia's circuit requirement of (4) ATS voice circuits and (3) AFTN circuits and card requirement of (2) E1 Daughter cards (reference RFP Appendix B and C), AGS assumes that (1) of the Daughter cards is intended for an MPS A empty slot and (1) for an MPS B empty slot, thereby providing redundant paths. AGS also assumes that since there is no requirement for V.24, Multi I/O, or Universal I/O cards, that existing cards have available ports to accommodate a V.35 interface to the MEVA II Linkway and (3) V.24 ports (from existing Multi I/O or Universal I/O) for the needed AFTN circuits. AGS can price and provide (2) additional Universal I/O cards (Primary and Secondary) to cover the V.35 and V.24 circuits if necessary. However, since Colombia's existing Memotec (Primary and secondary) have only (1) empty card slot, AGS recommends that REDDIG implement (2) new Memotec (960e) units and tie them to the existing Memotecs if needed.

- COCESNA – The COCESNA Memotec has (4) empty card slots, which is more than enough to accommodate additional circuits.
- Remaining REDDIG sites – AGS assumes that the REDDIG sites that are to receive additional Memotec cards have available slots for them.

CONFIDENTIAL

3.1.5 Outdoor Unit (ODU) Requirements *RFP 2.1.2.2*

By using an L-Band-based satellite modem, the MEVA II and REDDIG networks can share a site's existing IFL and RF chain (BUC and LNB). AGS uses the Terrasat Intelligent Block Up converter (IBUC) to meet these requirements. The Terrasat IBUC provides excellent performance in terms of power and performance, and offers a robust Monitor and Control capability. Attachment D provides specifications on the Terrasat IBUC and 1+1 redundant switch. During AGS' site survey visit, our technician will assess the condition of each site's IFL to verify suitability for interconnecting both networks. If the assessment shows that the IFL is acceptable, we will use it to interconnect both networks. If a discrepancy is present, AGS will note in a site survey report, along with recommended actions and a quote outside the scope of this proposal to resolve the discrepancy.

3.1.6 MEVA II / REDDIG Antenna System *RFP 2.1.2.3*

During AGS' site survey visit, our technician will assess the condition of each site's antenna system to verify suitability for interconnecting both networks. If the assessment shows that the antenna system is acceptable, we will use the site's existing antenna system to interconnect both networks. If a discrepancy is present, AGS will note in a site survey report, along with recommended actions and a quote outside the scope of this proposal to resolve the discrepancy.

3.1.7 Desired Space Segment Architecture *RFP 2.1.2.5*

The INTELSAT IS-1R satellite will be used by the MEVA II Service Provider (AGS) and the REDDIG Administrator to provide telecommunications services for the MEVA II / REDDIG Interconnection. In order to Interconnect the two networks, MEVA II will need to transition to Vertical Co-Pol. AGS will implement this change upon authorization by the MEVA II members.

3.1.8 Remote VSAT Site & Terminal Addressing *RFP 2.1.2.6*

Addressing and control of the VSAT terminal will be provided by the respective network control system. In addition to addressing and controlling the interconnected VSAT terminals the systems will be capable of simultaneously addressing their respective VSAT terminals, in the MEVA II or REDDIG networks.

3.1.9 Acquisition & Synchronization *RFP 2.1.2.7, App A*

Because the Doppler motion of the satellite and oscillator drift normally cause timing variations, maintaining synchronization is critical to the error-free operation of any network. Linkway terminals use TDMA acquisition and synchronization procedures to establish and maintain burst synchronization. Linkway procedures enable new terminals to join the network quickly. Typically, a MEVA II/ REDDIG interconnection terminal will enter the network within 30 seconds of power up. Typically, the TDMA NCC/NMS control system procedures enable the TOC to report any MEVA II /REDDIG Interconnection VSAT terminal equipment or link

CONFIDENTIAL

Use, duplication and disclosure of the information contained on this page is subject to the restrictions contained in the CONFIDENTIAL NOTICE on the title (first) page of this proposal.

performance alarm or a loss of service condition within 30 seconds of such an incident.

3.1.10 Clock Management *RFP 2.1.2.8*

Miami Hub and AGS Woodbine teleport use Stratum 1 clocks. Stratum 1 is defined as a completely autonomous source of timing, which has no other input, other than perhaps a yearly calibration. The usual source of Stratum 1 timing is an atomic standard or reference oscillator. The minimum adjustable range and maximum drift is defined as a fractional frequency offset f/f of 1×10^{-11} or less. At this minimum accuracy, a properly calibrated source will provide bit-stream timing that will not slip relative to an absolute or perfect standard more than once every 4 to 5 months.

3.1.11 Network Management Requirements *RFP 2.1.2.9, App A*

The MEVA II NCC stores all the configuration information for the MEVA II Linkway network. The NCC software reads the configuration information into memory (RAM) at network startup. The RAM copy is used during network operation. Configuration data specific to Linkway terminals are downloaded from the NCC to the terminals when the terminals are synchronized with the network. The configuration files are rewritten only when configuration information changes, such as when additions, deletions, or modifications are made. At terminal startup—and upon any configuration changes—the NCC downloads configuration data. Should the configuration data change; the NCC sends modifications to the terminals. The MEVA II NCC (and the ANCC) will generate the bootfiles for the MEVA II component of the Colombia and Venezuela sites and store their configuration information as well.

3.1.12 Internet Protocol (IP) Services *RFP App A*

The AGS installed Linkway dynamically routes IP packets using RIP-1, RIP-2, OSPF, and BGP-4 protocols, and supports unicast and multicast services, as well as static and default routing. Linkway also supports RFC 1490 for IP access over Frame Relay. A native 10BaseT Ethernet connection simplifies connectivity between the terrestrial networking equipment and the Linkway terminal. The Linkway system manages the routing table for IP and dynamically assigns bandwidth as needed. When a point-to-multi-point burst is allocated for a data stream, all network nodes designated a “control group” receive the burst assignment. Linkway allows multicast traffic bandwidth classified as real-time connections to be assigned a higher priority than unicast traffic. Additionally, the operator can manage the available bandwidth by specifying a unicast allocation factor. A variety of applications are possible with native IP support, including data multicasting, video streaming, voice over IP, and LAN-to-LAN and WAN-to-LAN connections.

3.1.13 Frame Relay (FR) Service *RFP App A*

The MEVA II VSAT terminal is capable of supporting UNI/NNI connection level with ANSI or ITU local management interface (LMI) access management and is compliant with the following ITU and ANSI standards:

CONFIDENTIAL

Use, duplication and disclosure of the information contained on this page is subject to the restrictions contained in the CONFIDENTIAL NOTICE on the title (first) page of this proposal.

Standards:	ITU-T	ANSI
Service Description:	I.233	T1.606
Core Aspects:	Q.922	T1.618
Signaling for VCs:	Q.933 Annex A	T1.617 Annex D

Table 4: ITU and ANSI Standards

All remote sites are preconfigured prior to being deployed to the site for installation. Once a site is installed all setup and provisioning is accomplished from MEVA II NCC/NMS.

3.1.14 Frame Relay Service Provisioning *RFP App A*

Provisioning Frame Relay service is extremely simple using the NMS and involves two steps:

1. **Configuring the serial interface for Frame Relay service**—Select the rate of transmission, clock source, and type of interface (RS 449, V.35, EIA 530). Specify the local management interface (LMI) type—ANSI or ITU—and other related parameters.
2. **Configuring the connection**—Select both source and destination sites and interfaces, and other related QoS parameters (e.g., CIR and Bc). Once these choices are made, the NMS automatically downloads the configuration to the NCC, which sends it to all relevant terminals, and the LinkWay system is ready for Frame Relay traffic

Incoming traffic is policed for frames in excess of the specified CIR and tagged appropriately. In the event an interface or terminal goes down, the connection at the other end is reported as inactive, and bandwidth is de-allocated. When the interface recovers, the connection is re-established.

3.1.15 Considerations of MEVA II and REDDIG NCC/NMS: *RFP 2.1.2.4*

AGS shall provide the boot files for the Colombia/MEVA II node and the Caracas/MEVA II node. AGS’s NCC shall perform overall monitoring and control (M&C) functions required for these two Interconnect nodes. The REDDIG service provider shall provide the boot files for the COCESNA/REDDIG node. REDDIG’s NCC shall perform overall monitoring and control (M&C) functions required for this Interconnection node. Remote terminal configurations contained in the AGS generated boot files will be downloaded via the satellite link to the respective terminals.

The MEVA II MRT, which is a part of the MEVA II primary NCC is located at the Miami ARTCC Hub and provides all network timing controls and synchronization for the MEVA II services. The configuration and control of the MRT is under the direct control of AGS personnel. AGS has installed a geographically diverse, Alternate NCC and ARMT at its Woodbine, Maryland Teleport. This ANCC and

CONFIDENTIAL

Use, duplication and disclosure of the information contained on this page is subject to the restrictions contained in the CONFIDENTIAL NOTICE on the title (first) page of this proposal.

AMRT will provide back up control, timing and synchronization should the primary NCC fail or there is a sun outage at the primary MRT site.

3.1.16 System Software *RFP 2.5.2*

All system software including the operating systems software and firmware are embedded in the devices that are provide. The software used for the interconnection is already part of the MEVA II network and the REDDIG network. No additional software will be used in the Interconnection.

3.2 Implementation Plan *RFP 2.3.1*

AGS will provide and facilitate the maintenance, repair, and replacement of all components necessary for interconnection services for MEVA II and REDDIG. AGS will install the components at the three Interconnect sites in coordination with the REDDIG Administrator. AGS will ship Memotec cards to be installed in Ecuador to the site to be installed by the site technicians. AGS technicians will install cards for additional services at all MEVA II sites.

3.2.1 Network Preparations

To accommodate the increased traffic from additional circuits, AGS will have to increase the amount of MEVA II operational bandwidth. This requires coordination of all MEVA II sites to schedule a brief down time to configure the Linkway Network Control Computer (NCC) with the new frequencies and push new boot files to all MEVA II site Linkway Traffic Terminals (TT). To minimize risk of extended down time due to a site's Linkway not taking the download, AGS will provide copies of the necessary boot files to each site and will guide them to manually load the file. AGS will also have technicians on standby to travel to the site if necessary. AGS will work with MEVA representatives assigned to the MEVA / REDDIG Working Group to coordinate this activity. For COCESNA to be interconnected into REDDIG, REDDIG administrators must ensure adequate bandwidth is available for the additional lines. The addition of the designated REDDIG sites into the MEVA II network will not affect current MEVA II availability or service level requirements already agreed upon. Attachment A includes link budget calculations for the applicable sites.

3.2.2 Site Survey

Upon contract award, AGS will schedule a site survey. An AGS representative will visit each MEVA II Interconnect site if required and collect information necessary to perform the implementation. Each Interconnect site will need to provide information requested regarding termination points, punch downs, available rack space, etc to ensure a complete survey report. Within one (1) week of the site survey completion, AGS will submit a site survey report that will detail the work to be done at the site, points of contact, operational considerations, logistical items, and any out of scope work with quotes. When scheduling the site survey, the AGS representative will require assistance from the applicable site regarding Visa and work permit requirements, points of contact, and recommended hotels, etc.

CONFIDENTIAL

Use, duplication and disclosure of the information contained on this page is subject to the restrictions contained in the CONFIDENTIAL NOTICE on the title (first) page of this proposal.

3.2.3 Procurement

Upon contract award, AGS will order the necessary major equipment. After the site survey report is completed, AGS will order the necessary installation items and acquire the necessary installation tool kits and test equipment.

3.2.4 Civil Works

If it is determined during the site survey that the existing IFL has too much loss to close both links, AGS will propose IFL that will meet link requirements. All civil works necessary to accommodate new IFL (new conduit, trenching, etc) will be the responsibility of the site.

3.2.5 Licensing

AGS will provide each interconnect site with the necessary system operating parameters, frequencies, etc in order for the site to file for all required licensing.

3.2.6 Configuration, Integration, and Testing *RFP 2.4*

Once all equipment is received at AGS' integration facility in Hagerstown, MD, AGS engineering and production staff will configure the system components, and test by inserting into a test node. From the site survey information, AGS will manufacture needed connecting cables to length and install in a test rack. These cables will be tied in and labeled and photographed to act as a guide for the field technician to install at the site in the same manner. This makes for a clean and organized install, which simplifies documentation and makes troubleshooting easier. For the REDDIG sites, AGS will place their test node into the MEVA II network to test connectivity to the appropriate MEVA II sites. AGS can perform the same test on COCESNA's REDDIG interconnect equipment, through coordination with REDDIG administrators. Once all system components have been configured and tested, they will be inventoried and prepared for shipment.

3.2.7 Shipping

AGS conducts an inventory of all equipment and installation materials, which is checked by the Program Engineer or Program Manager prior to shipment. AGS will send each site the following documentation into order to facilitate clearing the items through Customs:

- Commercial Invoice
- Shipper's Export Declaration
- Air Waybill
- Packing List

The site will be responsible for clearing the items through Customs and transporting to their site.

3.2.8 Installation and Testing *RFP 2.4*

Two weeks after confirmation that system components and installation materials have cleared Customs and are on site, AGS will schedule the dispatch of one field technician to perform the installation and testing. Prior to departure, AGS will

CONFIDENTIAL

Use, duplication and disclosure of the information contained on this page is subject to the restrictions contained in the CONFIDENTIAL NOTICE on the title (first) page of this proposal.

submit personnel information, travel itineraries, and a listing of all hand-carried tools and test equipment. Each site is requested to assist the AGS team in clearing all tools and test equipment through Customs in a timely fashion to avoid delays and additional charges. The installation teams will be on site for approximately three (3) days to perform the following:

- Installation of system components – Linkways, Memotec cards, RF components
- Assist site in connecting to terminal equipment
- Activating and testing new circuits
- Cleaning up installation site
- Providing REDDIG sites with MEVA II overview

AGS will ship the additional Memotec cards Ecuador. This proposal assumes that technicians at these sites will install the Memotec cards and test with AGS as they activate the Interconnect sites.

While the customer requires that service implementation occurs without interruption of service on the REDDIG or MEVA II networks, outage time **MUST** occur to implement. The three Interconnect sites must have down time to install the new BUCs, any new cards in the Memotec, and Interconnect Linkway modems as well. Other MEVA II and REDDIG sites receiving cards will also have to schedule downtime, since the Memotec must be powered down to install.

3.2.9 Technical Documentation *RFP 2.5.1*

Within 60 days after completion, AGS will provide two sets of site as-built engineering records to each affected end-user. The records shall include a system block and level diagram, cable and circuit connection lists, and all other details reflecting each installed site configuration as they pertain to the interconnection. AGS will also provide (2) sets of related equipment manuals

3.3 Operations and Maintenance Activities

3.3.1 Network Control Center (NCC)

3.3.1.1 REDDIG NCC Responsibilities *RFP 2.1.2.4*

The REDDIG NCC is the responsibility of the REDDIG administrator and the REDDIG NCC shall continue to provide the overall remote control and monitoring functions at all its respective VSAT nodes. Also this NCC, through the co-located MRT, shall continue to provide overall network TDMA burst timing and synchronization for its respective VSAT nodes.

3.3.1.2 MEVA II NCC Responsibilities *RFP 2.1.2.4*

The MEVA II NCC is the responsibility of the MEVA II service provider (AGS) and the MEVA II NCC shall continue to provide the overall monitoring and control (M & C) functions for all its respective VSAT nodes. Also this NCC, through the co-

CONFIDENTIAL

Use, duplication and disclosure of the information contained on this page is subject to the restrictions contained in the CONFIDENTIAL NOTICE on the title (first) page of this proposal.

located MRT, shall continue to provide overall network TDMA burst timing and synchronization for its VSAT nodes.

3.3.1.3 Administrative coordination between AGS and REDDIG Administrator:
RFP 2.1.2.4

In case of any network problem or issue in a REDDIG node communicating with a MEVA II node, AGS agrees to follow the procedure below:

- (1) AGS TOC will call the REDDIG Administrator informing about the event. The TOC will open a trouble ticket and reference this ticket number to the REDDIG Administrator
- (2) The REDDIG Administrator will call the respective node and will establish an audio conference between AGS TOC and REDDIG local technicians, as necessary.
- (3) REDDIG Network Management Center, under control of the Administrator, will supervise communications between AGS TOC and REDDIG node technicians.
- (4) Only AGS TOC personnel may call the REDDIG Administrator to open or close the respective trouble ticket.

AGS expects and agrees to follow the procedure below in case of any network problem or issue in a MEVA II node communicating with a REDDIG node:

- (1) The REDDIG Administrator will call the AGS TOC informing about the event.
- (2) AGS TOC will call the respective node and shall establish an audio conference between REDDIG Administrator and local technicians as necessary.
- (3) The AGS TOC will supervise communications between REDDIG Administrator and MEVA II node technicians.
- (4) The REDDIG Administrator is the only one that may call the AGS TOC to open or close the respective trouble ticket.

3.3.1.4 NCC Security RFP 2.1.2.4

Both the NCC and the ANCC are located in physically secure facilities access to which is restricted to authorized personnel only. The devices themselves are located inside locked cabinets.

The NCC (and the ANCC) maintains NMS operator login and password information as part of the configuration data and uses this information to authenticate operators trying to log into the system. The system has three levels of security:

- (1) **Full Access**—Allows the NMS operator to view and modify all configurable databases.

CONFIDENTIAL

- (2) **Read-Only Access**—Allows the NMS operator to view only the configuration data. This privilege can be further specified to limit access to configuration data of one or a set of terminals.
- (3) **Restricted Access**—Allows the NMS operator to read only portions of the network that have been specified.

AGS Teleport at Woodbine as well as the Miami Hub are supported by highly reliable commercial AC power, backed up by on site diesel generators and battery backup. All back up power systems are automatic and are tested periodically.

3.3.1.5 Network and Link Level Performance Monitoring *RFP App A*

The performance management function is useful in monitoring a terminal's health and for diagnosing problems. It enables the NMS operators to view transmit and receive burst data and to collect performance data—BER and link statistics and IP traffic—from individual terminals. The NMS operator can also assess service statistics from Frame Relay connections. The NCC collects data for each burst containing the selected connection. Data are gathered for channel access control transmissions to and from the satellite, and for the terrestrial interfaces by link and connection. The operator can collect performance statistics from individual terminals for monitoring the health of a particular terminal and for diagnosing problems. Various fault alarms are collected from the terminals and distributed to the NMS for display on the operator screen.

Some of the important performance parameters monitored are:

- Statistics for each receive burst.
- Accumulated statistics for each transmit burst.
- Accumulated statistics on a per destination basis (e.g., number of packets sent, allocated packet bandwidth, average number of bytes per sec).
- Packets dropped at a node.
- Packets forwarded at a node.
- Throughput on the link.

The Alarm Management function collects information on various fault alarms from the terminals and relays the messages to the NMS for display. Alarms may be either:

- Posted immediately, as when a terminal goes down and a Beep Alarm List window is automatically displayed.
- Posted with no notification, as when an interface goes down.

Alarms relate only to equipment failure and not to congestion, transmission faults or other problems within the network. An audible beep alarm is issued and a Beep Alarm List window is displayed should a terminal go down or the NMS lose connection with the NCC. The NMS operator must acknowledge the message to turn off the audible alarm.

CONFIDENTIAL

The Terrestrial Interface Alarms window displays information for all active alarms in the system created by failures at the interface card level in network terminals. The fields displayed in this window include:

- **Alarm Type**—Identifies what kind of failure is occurring.
- **Site ID**—Identifies the site.
- **Interface**—Identifies the interface.
- **Terminal ID**—Identifies which terminal at a site is involved.

3.3.2 Technical Operations Center (TOC) *RFP 2.1.2.4*

AGS’s Technical Operations Center (TOC) located at our Woodbine, Maryland Teleport is manned with English-speaking operations staff, 24 hours a day, 7 days a week, 365 days of the year. To communicate with non-English speaking customers, the TOC uses translation services from CTS Language Services. MEVA II has English, Spanish, and French speaking customers, so this offers us even more flexibility, as we have access to translation services for multiple languages. The translation service will be used in the following manner:

- A Spanish-speaking customer calls in to the TOC to report an outage.
- The TOC then conferences in the translator and continues to work with the customer to isolate and resolve the problem. .

AGS’s Technical Operations Center (TOC) currently has (2) switched voice lines on the MEVA II network (X2400 and X2401). The TOC also has a POTS line that can be used to contact technical staff.

The TOC assigns trouble ticket numbers as soon as a call detailing network outage is received. The TOC will proactively escalate troubles based on the severity and duration of an outage. Phone numbers and contact information are provided below if an escalation on the trouble ticket is desired. Note: a ticket must be opened with the TOC prior to any escalations. **These escalation time frames apply to circuit outages only.**

Level 1 – Initial Call	
Name/Group	SES TOC
Phone Number	U.S: toll free 866-244-5012 Outside of the U.S.: +1-410-970-7700
E-mail	nmcsupport@ses-amicom.com
Fax:	410-795-5893

Level 2 – Hour 2	
Name/Group	TOC LEVEL II Engineer
Desk Phone	+1-410-970-7710
E-mail	nmcsupport@ses-amicom.com
Fax:	410-795-5893

CONFIDENTIAL

Use, duplication and disclosure of the information contained on this page is subject to the restrictions contained in the CONFIDENTIAL NOTICE on the title (first) page of this proposal.

Level 3 – Hour 4	
Name/Group	Ron Teske, Operations Manager, Eastern Region
Desk Phone	+1-301-474-2332
Cell Phone	+1-410-382-3846
E-mail	ron.teske@americom-gs.com

Table 5: Interconnection TOC Escalation Levels

The AGS Operations Manager will make the determination if a spare unit requires shipment or an AGS technician or engineer needs to be dispatched. As per the RFP, the Interconnect site’s technical staff is responsible for site maintenance. AGS is providing in the proposal a list of on site spares to expedite system restoration. AGS technician or engineer dispatch will be quoted separately and on a case-by-case basis.

3.3.2.1 Network Security Management *RFP App A*

AGS maintains strict controls with regards to network security management. As with MEVA II, the Interconnection sites will meet the following:

- No site will have direct communications with public networks.
- Network equipment is used only for MEVA II and MEVA II / REDDIG interconnection.
- The network exclusively supports services for which it was originally designed.

3.3.3 Plan for Maintenance, Repair and Replacement of Existing Equipment

To minimize down time and maximize quality of service, AGS proposes the following plan for the Maintenance, Repair, and Replacement of Interconnect equipment.

3.3.3.1 Spares *RFP 2.3.1*

Based on the fact that Bogotá and Caracas have redundant systems AGS assumes no spares for the REDDIG sites are necessary. No additional spares are necessary for the existing MEVA II sites because of the existing MEVA II spares pool. COCESNA has a set of spare components as part of the MEVA II network.

3.3.3.2 On-site maintenance

As per section 2.3.3 of the RFP, Interconnect equipment residing at a REDDIG site will be maintained by the respective REDDIG member state, and COCESNA technical staff, in coordination with the AGS TOC, will maintain Interconnect equipment residing at COCESNA. AGS technical staff will maintain all other MEVA II sites communicating with REDDIG, unless a member state has a separate maintenance agreement where they maintain the equipment.

3.3.3.3 Repairs and Replacements *RFP 2.3.2*

Coordination between AGS and the REDDIG Administrator will be handled as stated in section 3.3.1.3 of this response. The applicable coordination entity will

CONFIDENTIAL

Use, duplication and disclosure of the information contained on this page is subject to the restrictions contained in the CONFIDENTIAL NOTICE on the title (first) page of this proposal.

direct troubleshooting efforts and dictate components to be replaced. The responsible REDDIG site technician (for REDDIG sites), COCESNA technician (for COCESNA site), and AGS technical staff (for other MEVA II sites) will carry out the component replacements. For the failed component, the AGS TOC will open a Return Material Authorization (RMA) with the equipment manufacturer. The TOC will obtain the RMA number based on information provided by the affected site including but not limited to component, serial number, and description of problem. Once the RMA number is obtained, the TOC will pass on to the affected site. The site will be responsible for preparing and shipping the component back to the repair facility. The site must ship the component within 48 hours of receiving the RMA number. If the repair activity determines that the component failure is due to user error or force majeure (lightning strikes, etc) then the affected site will be responsible for paying for the repair.

3.3.4 Plan for Routine Equipment Maintenance and Emergency Repairs RFP 2.3.3

All sites maintaining their own equipment that accesses the MEVA II network must do so in accordance with the coordination terms of this proposal. All maintenance must be performed in accordance with manufacturers' recommendations and the AGS Advanced Technician Training Guide (Appendix F of this proposal). The Advanced Technician Training Guide provides a plan for routine maintenance checks, and for emergency repairs as well. Scheduled outage events must be coordinated with the AGS TOC and the REDDIG Administrator fourteen days prior to the occurrence (if feasible). The training Guide provides a form that must be submitted to the AGS TOC for scheduled outages.

3.3.5 Scheduled Maintenance Notification

AGS will provide scheduled maintenance notification to the end user within fourteen days prior to a scheduled outage in a MEVA II site that communicates with REDDIG. AGS understands that the REDDIG Administrator will notify the AGS TOC fourteen days prior to a scheduled outage in a REDDIG node that communicates with MEVA II

3.3.6 Transponder Failure

In the event of a transponder failure, AGS would move the MEVA II bandwidth to equivalent bandwidth on another transponder on the same satellite. Should the IS 1R satellite no longer be usable for some reason, AGS would move the MEVA II bandwidth to another satellite, with similar coverage. Such a catastrophic situation would require re-pointing each member countries antenna. With the help of personal at each MEVA II remote site this can be accomplished in a relatively short time. This recovery would also require reconfiguring the frequencies in each Linkway modem as described above when moving to another transponder.

3.3.7 Service Provider Initiated Network Changes

CONFIDENTIAL

Use, duplication and disclosure of the information contained on this page is subject to the restrictions contained in the CONFIDENTIAL NOTICE on the title (first) page of this proposal.

3.3.7.1 Change Notifications *RFP 2.6.1*

AGS will notify the ICAO points of contact in writing at least 60 days in advance of all significant planned changes to the configuration of the MEVA II/REDDIG interconnection services; changes in equipment or software that affect MEVAII/REDDIG interconnection functionality or performance, or changes in space segment configuration. Such changes will be accompanied by sufficiently detailed engineering documentation and explanation. The ICAO points of contact will receive change notices from AGS at least 30 days prior to the start of work on such changes. AGS will obtain the approval of the ICAO points of contact at least 30 days prior to performing any planned changes that would adversely affect MEVAII/REDDIG interconnection services, including any periods of service outage for equipment maintenance or equipment/software changes.

3.3.8 Activation of New Services *RFP 2.7*

AGS will work with any interconnect site to propose requested additional services. AGS will have individual service orders with each applicable member state that can be modified to add services as they are requested.

3.3.9 Discontinuation of Service *RFP 2.8*

Upon termination of service, AGS will remove all AGS-owned equipment.

3.3.10 Reports *RFP 2.1.2*

AGS will provide each MEVA II/REDDIG interconnection end-user with a monthly report showing bandwidth usage, call record details, system performance statistics and trouble log summary. The trouble log will include a trouble ticket identifier, date and time, problem description, cause and repair, and both users and providers operators and/or technician's names.

AGS will maintain an online database, which will include current network status, call record list, call statistics, trouble report list which will be accessible by the user. Each user will be supplied a user ID and password to access the site via the Internet.

3.3.11 MEVA II / REDDIG Program Administration *RFP 2.9*

The AGS Program Manager will support the MEVA II TMG, REDDIG Coordination Group, the MEVA and REDDIG Member States / Territories / International Organizations in program management and administrative activities. The AGS PM or a designated representative will attend meetings or participate in conference calls scheduled by ICAO, REDDIG Coordination, or the MEVA TMG.

CONFIDENTIAL

Use, duplication and disclosure of the information contained on this page is subject to the restrictions contained in the CONFIDENTIAL NOTICE on the title (first) page of this proposal.

3.4 System Performance

3.4.1 Satellite Link Availability *RFP App A*

AGS's standard availability for TDMA Bandwidth On Demand is 99.5%. However, AGS has designed the MEVA II Network with an availability of 99.9%. The increase in availability requires that a larger uplink SSPA be used, as much as 40 watts in some cases. AGS will also implement uplink power control (UPC) on all links to improve the link availability.

The Linkway NMS allows for link availability reporting over a rolling twelve-month period. This report can be generated from the MEVA II NMS terminal.

AGS will design and maintain the satellite links whereby they will meet an average BER of 1×10^{-6} BER as measured over a 24-hour rolling period.

When the link becomes worse than 1×10^{-4} for a period exceeding 10 continuous minutes AGS will declare the circuit out of service. At this time (if not sooner) the AGS NMS will begin trouble resolution procedures and if necessary dispatch a technician to the affected site, providing a maintenance agreement has been executed with that Member State.

When the link exceeds 6 carrier dropouts per minute, AGS will declare the circuit out of service. At this time (if not sooner) the AGS NMS will begin trouble resolution procedures and if necessary dispatch a technician to the affected site, providing a maintenance agreement is in place.

AGS recognizes and agrees that service outages cannot be counted toward link availability. Sun outages will not be counted against the overall link availability. AGS will post Sun outage reports prior the first occurrence.

3.4.2 Switched Voice Circuit Call Blocking Performance *RFP App A*

AGS has designed the network so that voice circuits will have a call blocking probability of no greater than .1% at all times. This exceeds the specification requirement of 5% and includes peak call volumes as specified for peak holiday periods.

3.4.3 Data Circuit Latency Performance *RFP App A*

The AGS designed data circuits will not have latency greater than 350 milliseconds between demarcation points. See Attachment A for Link Budget Information.

CONFIDENTIAL

3.4.4 Quality of Service (QoS) Parameters *RFP 2.3.1*

AGS will comply with the Quality of Service (QoS) Performance Parameters stated below:

Parameter	Specification
1. Minimum acceptable performance of a half duplex (one-way) satellite RF link on the basis of BER performance:	a) Not less than 99.9% for a VSAT terminal link over the latest (rolling) 12-month period with a BER of $>1 \times 10^{-6}$ as measured over the latest (rolling) 24-hour period. b). A VSAT RF link BER worse than 1×10^{-4} for a period exceeding 10 continuous minutes. c). Intermittent VSAT RF link outages (periodic dropouts or RF carrier chopping) exceeding six (6) dropouts per continuous minute.
2. Maximum Service Restoration Time due to any cause (excluding AGS response time and reasonable travel time to the affected site):	24 hours
3. Maximum Routine Preventive Maintenance Service Interruption Time:	8 hours per year
4. Minimum Interval between Service Interrupting Routine Preventive Maintenance:	2190 hours
5. Maximum Number of Service Outages per latest (rolling) 12 month period due to any cause(s):	6

Table 6: Interconnection QoS Parameters

3.4.5 Credit Computation *RFP 2.3.1*

AGS will agrees to use the following criteria for credit computation in our solution:

Performance Requirements	Criterion for Assessing a Penalty	Credits Assessed for Each Incident based on Monthly Recurring Charges
1. Minimum Availability of a Satellite RF Link	A) Availability is less than specified	A: 100%
2. Maximum Service Restoration Time	A) Exceeds required restoration time by 10% B) Exceeds required restoration time by 100%	A: 10% B: 50% C: 100%

CONFIDENTIAL

Use, duplication and disclosure of the information contained on this page is subject to the restrictions contained in the CONFIDENTIAL NOTICE on the title (first) page of this proposal.

	C) Exceeds required restoration time by 300%	
3. Maximum Preventive Maintenance Service Interruption Time	A) Exceeds the maximum allowed time by 10% on a rolling 12-month basis B) Exceeds the maximum allowed time by 10% on a rolling 12-month basis for 12 or more consecutive months.	A: 50% B: 100%
4. Maximum Interval Between Service Interrupting Preventive Maintenance	A) Service interrupting preventive maintenance is performed after an interval that is less than the minimum interval by one hour or more. B) Service interrupting preventive maintenance per A) above is performed three or more consecutive times.	A: 50% B: 100%
5. Maximum Number of Outages (per latest 12 month period)	A) Exceeds the maximum number on a rolling 12-month basis. B) Exceeds the maximum number on a rolling 12-month basis for three consecutive months. C) Exceeds the maximum number on a rolling 12-month basis for four or more consecutive months.	A: 25% B: 50% C: 100%

Table 7: Credit Computation

3.4.6 Non-Compliance

Any abnormalities or indications of non-compliant operations will be logged and called to the immediate attention of the Government representative. If failures occur during the test period, the test technician will interrupt the test and make appropriate repairs and, after Government approval, continue the test until all remaining tests pass successfully.

CONFIDENTIAL

Use, duplication and disclosure of the information contained on this page is subject to the restrictions contained in the CONFIDENTIAL NOTICE on the title (first) page of this proposal.

4.0 Appendix 1F (ICAO)

AGS Volume I Technical Response:

- a) complete the studies necessary which either guarantee or not, the replacement of the current 40 W amplifiers in the COCESNA MEVA II node, as well as in the Caracas REDDIG node for 80 W amplifiers;

AGS has completed the analysis of link budgets, which indicates that the 40 W amplifier in the COCESNA MEVA II node will be sufficient for the interconnection. For the Caracas REDDIG node, AGS recommends an 80 W amplifier. AGS analysis is supported by analysis from Intelsat when multi-carrier backoff is included.

- b) contemplate for the Caracas and Bogotá REDDIG nodes only one MODEM, as specified in Appendix C to the RFP and in Appendix B to Agenda Item 1 to the Report of the Fourth MEVA II / REDDIG Coordination Meeting;

AGS will provide one (1) Linkway 2100 satellite modem as required by the RFP. To maintain service upon RF chain failure, we will install splitters / combiners to both RF chains and connect to the MEVA II Linkway. Connecting the one Linkway to the redundant Memotecs can be accomplished in one of two ways. With the first method, a local technician can manually move the V.35 Linkway cable from the primary Memotec to the secondary Memotec. With the second method, we can install bridges to convert each V.35 to Ethernet and install a hub where the Linkway can feed both Memotecs simultaneously. If the MEVA / REDDIG working group is interested in this option, AGS can explore further by testing in the lab and pricing.

- c) modify the number of Frame Relay circuits (ATS voice circuits) between Bogotá and Panama, in accordance with the specifications contained in Appendix B to the RFP, Table 2 (see the remarks column) and in Appendix C to the RFP. Install four (4) Frame Relay circuits, Review the additional equipment needed in Panama, as a consequence of this change;

AGS Volume I - Technical submission Table 2 (p. 8) Changed 4 to 2.

- d) in the implementation of the AFTN circuits in Brazil, Peru and the United States via Bogotá, Colombia, the REDDIG Administration will implement the necessary equipment in the Peru and Brazil REDDIG nodes, the Frame Relay circuits programming between Peru-Colombia and Brazil-Colombia, as well as the FRAD technical arrangements in Bogotá and the connection to the MEVA II MODEM;

CONFIDENTIAL

Our original proposal assumed that REDDIG technical staff would install the necessary equipment in Peru and Brazil to connect these AFTN circuits. With this modification AGS assumes that REDDIG will also supply the necessary equipment at these sites for the interconnection of the two networks. AGS will assume no responsibility for equipment procured and installed by REDDIG for Peru and Brazil.

- e) in MEVA II the use of a carrier with capacity of 2.5 symbols per second should not be considered, as indicated in the response issued by the Third Meeting of the MEVA II / REDDIG Interconnection Task Force to questions formulated by the AGS to the RFP (Ref. Appendix B to this part of the Report);

AGS's current configuration does not include the use of a 2.5 Msps carrier.

- f) complete the necessary studies in order to determine that the MEVA II network MRT and AMRT are not simultaneously affected by the sun-outage phenomenon;

A sun outage is caused when the alignment of the sun (relative to the earth) falls in line with the path from the satellite to the earth station. Imagine the sun projecting a shadow of the satellite onto the earth. Wherever the shadow falls, there is a sun outage. (Since, at that point, the earth station antenna is looking directly into the sun, the Electro Magnetic Interference (EMI) level from the sun into the earth station antenna's main beam is at its peak. This raises the noise floor, which reduces the Carrier-to-Noise (C/N) level.) The earth is spinning on a tilted axis, relative to the sun. As the earth orbits the sun over the duration of a year this causes the sun to align directly perpendicular to different parts of the earth at different times of the year. This causes the seasonal changes and sun outages, twice a year, once in the spring and once in the fall.

As the sun moves north to south (relative to the earth), the shadow of the satellite moves south to north. The effect in the southern hemisphere is for the higher latitudes to be effected first. In the northern hemisphere the lower latitudes are affected first. As the sun moves south to north (relative to the earth), the shadow of the satellite moves north to south. The effect in the southern hemisphere is for the lower latitudes to be effected first. In the northern hemisphere the higher latitudes are affected first.

CONFIDENTIAL

Use, duplication and disclosure of the information contained on this page is subject to the restrictions contained in the CONFIDENTIAL NOTICE on the title (first) page of this proposal.

The table below lists the sun outage calculations for the Miami and Woodbine Earth stations through 2010. Please note that there is no overlap calculated between the two sites. Woodbine currently uses a 3.8M antenna, but will cut over to a new 7.2M antenna in November / December 2007.

	2007 Spring	2007 Fall	2008 Spring	2008 Fall	2009 Spring	2009 Fall	2010 Spring	2010 Fall
Miami		10/3-10/5	3/8-3/10	10/2-10/4	3/8-3/10	10/2-10/4	3/8-3/11	10/2-10/5
WDB 3.8M		10/6-10/11	3/2-3/6	10/6-10/10	3/2-3/7	10/6-10/10	3/3-3/7	10/6-10/10
WDB 7.2M		10/7-10/10	3/3-3/5	10/7-10/9	3/3-3/6	10/7-10/9	3/4-3/6	10/7-10/9

- g) considering the procedures established in the RFP for aspects of maintenance, it is necessary to establish a voice channel between the MEVA II NCC and REDDIG as well as a voice channel between the MEVA II NCC with the REDDIG nodes of Caracas and Bogotá;

Switched voice PVCs between Caracas and Woodbine and between Bogotá and Woodbine will be provisioned for maintenance purposes. If the customer uses existing switched voice lines then no additional charges will be incurred. If the customer requires additional lines for maintenance purposes then AGS will quote upon request.

- h) include in the response to the RFP the table of Credit Requirements Accomplishment specified in Section 2 of the RFP.

Included.

- i) update the programme of activities described in a) to h) above using the MS Project Management software.

Included.

- j) update block diagrams.

Included.

CONFIDENTIAL

Use, duplication and disclosure of the information contained on this page is subject to the restrictions contained in the CONFIDENTIAL NOTICE on the title (first) page of this proposal.

AGS Volume II Economical Response:

- a) in the non-recurring costs proposal included in Section II, Table 1 (Summary of the non-recurrent costs for the MEVA II REDDIG interconnection) delete the network integration costs, which include the installation and trips to Peru and Brazil, considering observations formulated in the Technical Proposal of the Brazil and Peru AFTN circuits;

The Network Integration, Install and Travel charges in Table 1 capture the non-recurring charges associated with implementing the network. These charges include program management, systems engineering, administrative costs and system design that affect all sites as well as integration, install, install travel, and other charges associated with the interconnect sites. The charges common to all sites were distributed evenly. The non-recurring charges included for Brazil and Peru only included the program management, systems engineering, administrative costs and system design costs that were shared by all sites. AGS will remove the non-recurring charges in this category for Brazil and Peru; however, these charges will be blended across the remaining sites.

- b) review the Site Survey costs as well as COCESNA's integration costs, shown in Table 1 of Section II, considering that AGS is already familiar with the COCESNA MEVA II node;

AGS removed the Site Survey costs for COCESNA in Table 1 of Section II.

- c) in Table 1 of Section II, delete all non-recurrent costs associated to Ecuador in view that all these will be the responsibility of the REDDIG Administration;

The Network Integration, Install and Travel charges in Table 1 capture the non-recurring charges associated with implementing the network. These charges include program management, systems engineering, administrative costs and system design that affect all sites as well as integration, install, install travel, and other charges associated with the interconnect sites. The charges common to all sites were distributed evenly. The non-recurring charges included for Ecuador only included the program management, systems engineering, administrative costs and system design costs that were shared by all sites. AGS will remove the non-recurring charges in this category for Ecuador; however, these charges will be blended across the remaining sites. Non-recurring charges associated with equipment and shipping are deleted from Table 1 for Ecuador.

CONFIDENTIAL

- d) detail unitary prices of equipment and services proposed in Table 1 of Section II;

A list of equipment and services is provided in Tables 2 and 3 of our technical submission. Our pricing proposal is firm, fixed price and bundled pricing includes integration, implementation, testing, program management, systems engineering, administrative costs and system design, travel, shipping, site surveys, etc. Although we separated these items into categories our offer remains a firm, fixed price. AGS provides a turn-key solution with value added services.

- e) in Table 2 of Section II, review monthly costs of network access taking into account costs presented by AGS in the Fourth MEVA II / REDDIG Coordination Meeting held in Lima, Peru from 7 to 9 March 2007;

This proposal supercedes any budgetary pricing provided previously by AGS.

and

- f) update the recurrent costs presented in Table 2 of Section 2 in accordance with the changes performed by the technical proposal.

Included.

CONFIDENTIAL

Use, duplication and disclosure of the information contained on this page is subject to the restrictions contained in the CONFIDENTIAL NOTICE on the title (first) page of this proposal.

Attachment A: Link Budgets

Our Satellite Link Budget Performance Analysis for the Interconnection nodes and their associated connection requirements is based on a vertical co-pol C-band configuration on the IS-1R satellite (previously known as PAS-1R). Implementation of the Interconnection solution is contingent upon MEVA II's authorization to transition the MEVA II network to vertical co-pol. AGS presented a Rough order of Magnitude (ROM) through ICAO Mexico and is awaiting response.

CONFIDENTIAL

Use, duplication and disclosure of the information contained on this page is subject to the restrictions contained in the CONFIDENTIAL NOTICE on the title (first) page of this proposal.

Satellite Link Budget Calculation Americom Government Services

<u>CIRCUIT</u>	<u>SATELLITE</u>	<u>PROJECT INFO</u>
Link #: 001a	Satellite: PAS1R-COPOL	Project Name: REDDIG
Information Rate: 1875000 + 0 bps	Orbital Position: 45.0 W	System Engineer: D.Sahu
Availability: 99.9000%	Transponder: C-Band	Contract Length: 60 months
Bit Error Rate: 1.0E-07	Transponder Beam: N/SAM	Contract Phase: 1
Modulation: QPSK	Input Backoff: 5.0 dB	Manufacturer: Comsat
Inner FEC: VITERBI (R-3/4)	Output Backoff: 3.5 dB	Modem Model: LinkWay2000
Outer FEC: REED-SOLOMON (R-216/236)	Multi-Carrier BO: 15.6 dB	Txp BW Usage: 1776.000 KHz
Uplink Freq: 6175.0 MHz	SFD @ 0 dB/K: -97.1 dBW/m	Txp BW Usage: 4.93%
Downlink Freq: 4000.0 MHz	Input Atten: 6.2	Txp Pow Usage: 2.73%
Buffer Required: 808.00 bits	Polarization: Linear	Power:BW Ratio: 0.55
Delay (E-to-E): 248.99 msec	Transponder BW: 36.0 MHz	Total Txp Usage: 1776.00 KHz
	Beam Center EIRP: 43.7 dBW	Project Number: D.Benning

<u>UPLINK</u>	<u>DOWNLINK</u>
Site ID: COL	Site ID: CUR
Type: VSAT	Type: VSAT
Location: Bogota, Columbia	Location: Willenstad, Curacao
Latitude: 4.63 N	Latitude: 12.20 N
Longitude: 74.08 W	Longitude: 68.97 W
Altitude: 10.0 meters	Altitude: 220.0 meters
Azimuth: 98.21	Azimuth: 115.28
Elevation: 55.70	Elevation: 58.81
Polarization: -80.53	Polarization: -61.98
Satellite G/T: 0.00 dB/K	Satellite EIRP: 41.50 dBW
Antenna Diameter: 3.70 meter	Antenna Diameter: 3.80 meter
Antenna Gain: 46.30 dBi	Antenna Gain: 41.80 dBi
Circuit EIRP: 50.75 dBW	Antenna Noise: 21.00 K
HPA Power: 3.69 Watts	LNA Temperature: 20 K
HPA Power: 5.67 dBW	G/T (Clear): 24.2 dB/K
Flange Density: -20.88 dBW/4KHz	G/T (Rain): 23.7 dB/K
FCC Maximum: -2.80 dBW/4KHz	D/L Power Density: -1.6 dBW/4KHz (Max = 6.0)

UPLINK PATH CALCULATIONS

Slant Path Dist:	36742.0 km
Path Loss:	199.6 dB
Spreading Loss:	162.3 dB-m ²
0 Isotherm Ht:	4.9 km
Frequency:	6175.0 MHz
Polarization:	Vertical

INTERFERENCE ANALYSIS

	<u>Uplink</u>	<u>Downlink</u>
Adjacent Sat:	98.1 dB-Hz	92.1 dB-Hz
Cross-Pol:	92.1 dB-Hz	92.1 dB-Hz
Terrestrial:		92.1 dB-Hz
Adjacent Ch:		92.1 dB-Hz
I/No:	91.2 dB-Hz	86.1 dB-Hz

DOWNLINK PATH CALCULATIONS

Slant Path Dist:	36578.8 km
Path Loss:	195.8 dB
Spreading Loss:	162.3 dB-m ²
0 Isotherm Ht:	4.9 km
Frequency:	4000.0 MHz
Polarization:	Vertical

RAIN ANALYSIS

	<u>Uplink</u>	<u>Downlink</u>
Crane Region:	H	G
Availability:	99.9500 %	99.9500 %
Point Rain Rate:	77.0 mm/hr	33.0 mm/hr
Attenuation:	3.0 dB	0.2 dB
Rain Noise:		7.0 K
G/T Degradation:		0.5 dB
Absorbtion:		
U/L Power Control:	0.0 dB	

CARRIER TO NOISE ANALYSIS

	<u>Both Faded</u>	<u>U/L Faded</u>	<u>D/L Faded</u>	<u>No Fading</u>
U/L Thermal:	76.8 dB-Hz	76.8	79.8	79.8
D/L Thermal:	75.4 dB-Hz	76.1	78.5	79.2
System C/No:	72.8 dB-Hz	73.1	75.5	75.9
System C/N:	10.6 dB	11.0	13.4	13.7
System Eb/No:	8.4 dB	8.8	11.2	11.5
Sat Flux Density:	-174.6 dBW/m ²	-174.6	-171.5	-171.5
D/L Pow Density:	-4.6 dBW/4KHz	-4.6	-1.6	-1.6
Carrier Sat EIRP:	19.3 dBW	19.3	22.4	22.4
Carrier BO:	18.7 dB	18.7	15.6	15.6
% Txp Usage:	1.4 %	1.4 %	2.7 %	2.7 %
Link Margin:	0.8 dB	1.2	3.6	3.9
C/N (Uplink):	n/a	n/a	n/a	13.4
C/N (WOD):	n/a	n/a	n/a	15.4

Notes:

Satellite Link Budget Calculation Americom Government Services

<u>CIRCUIT</u>	<u>SATELLITE</u>	<u>PROJECT INFO</u>
Link #: 002a	Satellite: PAS1R-COPOL	Project Name: REDDIG
Information Rate: 1875000 + 0 bps	Orbital Position: 45.0 W	System Engineer: D.Sahu
Availability: 99.9000%	Transponder: C-Band	Contract Length: 60 months
Bit Error Rate: 1.0E-07	Transponder Beam: N/SAM	Contract Phase: 1
Modulation: QPSK	Input Backoff: 5.0 dB	Manufacturer: Comsat
Inner FEC: VITERBI (R-3/4)	Output Backoff: 3.5 dB	Modem Model: LinkWay2000
Outer FEC: REED-SOLOMON (R-216/236)	Multi-Carrier BO: 10.8 dB	Txp BW Usage: 1776.000 KHz
Uplink Freq: 6175.0 MHz	SFD @ 0 dB/K: -97.1 dBW/m	Txp BW Usage: 4.93%
Downlink Freq: 4000.0 MHz	Input Atten: 6.2	Txp Pow Usage: 8.25%
Buffer Required: 808.00 bits	Polarization: Linear	Power:BW Ratio: 1.67
Delay (E-to-E): 246.64 msec	Transponder BW: 36.0 MHz	Total Txp Usage: 2969.95 KHz
	Beam Center EIRP: 43.7 dBW	Project Number: D.Benning

<u>UPLINK</u>	<u>DOWNLINK</u>
Site ID: COL	Site ID: FRG
Type: VSAT	Type: VSAT
Location: Bogota, Columbia	Location: Cayenne, Fr_Guyana
Latitude: 4.63 N	Latitude: 4.93 N
Longitude: 74.08 W	Longitude: 52.33 W
Altitude: 10.0 meters	Altitude: 0.0 meters
Azimuth: 98.21	Azimuth: 123.58
Elevation: 55.70	Elevation: 79.63
Polarization: -80.53	Polarization: -55.93
Satellite G/T: 0.00 dB/K	Satellite EIRP: 36.00 dBW
Antenna Diameter: 3.70 meter	Antenna Diameter: 3.70 meter
Antenna Gain: 46.30 dBi	Antenna Gain: 42.50 dBi
Circuit EIRP: 55.56 dBW	Antenna Noise: 21.00 K
HPA Power: 11.16 Watts	LNA Temperature: 40 K
HPA Power: 10.48 dBW	G/T (Clear): 23.6 dB/K
Flange Density: -16.07 dBW/4KHz	G/T (Rain): 22.7 dB/K
FCC Maximum: -2.80 dBW/4KHz	D/L Power Density: 3.2 dBW/4KHz (Max = 6.0)

UPLINK PATH CALCULATIONS

Slant Path Dist:	36742.0 km
Path Loss:	199.6 dB
Spreading Loss:	162.3 dB-m ²
0 Isotherm Ht:	4.9 km
Frequency:	6175.0 MHz
Polarization:	Vertical

INTERFERENCE ANALYSIS

	<u>Uplink</u>	<u>Downlink</u>
Adjacent Sat:	98.1 dB-Hz	92.1 dB-Hz
Cross-Pol:	92.1 dB-Hz	92.1 dB-Hz
Terrestrial:		92.1 dB-Hz
Adjacent Ch:		92.1 dB-Hz
I/No:	91.2 dB-Hz	86.1 dB-Hz

DOWNLINK PATH CALCULATIONS

Slant Path Dist:	35874.8 km
Path Loss:	195.6 dB
Spreading Loss:	162.1 dB-m ²
0 Isotherm Ht:	4.9 km
Frequency:	4000.0 MHz
Polarization:	Vertical

RAIN ANALYSIS

	<u>Uplink</u>	<u>Downlink</u>
Crane Region:	H	H
Availability:	99.9500 %	99.9500 %
Point Rain Rate:	77.0 mm/hr	77.0 mm/hr
Attenuation:	3.0 dB	0.4 dB
Rain Noise:		18.4 K
G/T Degradation:		0.9 dB
Absorbtion:		
U/L Power Control:	0.0 dB	

CARRIER TO NOISE ANALYSIS

	<u>Both Faded</u>	<u>U/L Faded</u>	<u>D/L Faded</u>	<u>No Fading</u>
U/L Thermal:	81.6 dB-Hz	81.6	84.6	84.6
D/L Thermal:	73.7 dB-Hz	75.0	76.7	78.1
System C/No:	72.8 dB-Hz	73.8	75.5	76.5
System C/N:	10.6 dB	11.7	13.4	14.4
System Eb/No:	8.4 dB	9.5	11.2	12.2
Sat Flux Density:	-169.8 dBW/m ²	-169.8	-166.7	-166.7
D/L Pow Density:	0.2 dBW/4KHz	0.2	3.2	3.2
Carrier Sat EIRP:	18.6 dBW	18.6	21.7	21.7
Carrier BO:	13.9 dB	13.9	10.8	10.8
% Txp Usage:	4.1 %	4.1 %	8.2 %	8.2 %
Link Margin:	0.8 dB	1.9	3.6	4.6
C/N (Uplink):	n/a	n/a	n/a	14.2
C/N (WOD):	n/a	n/a	n/a	17.3

Notes:

Satellite Link Budget Calculation Americom Government Services

<u>CIRCUIT</u>	<u>SATELLITE</u>	<u>PROJECT INFO</u>
Link #: 004a	Satellite: PAS1R-COPOL	Project Name: REDDIG
Information Rate: 1875000 + 0 bps	Orbital Position: 45.0 W	System Engineer: D.Sahu
Availability: 99.9000%	Transponder: C-Band	Contract Length: 60 months
Bit Error Rate: 1.0E-07	Transponder Beam: N/SAM	Contract Phase: 1
Modulation: QPSK	Input Backoff: 5.0 dB	Manufacturer: Comsat
Inner FEC: VITERBI (R-3/4)	Output Backoff: 3.5 dB	Modem Model: LinkWay2000
Outer FEC: REED-SOLOMON (R-216/236)	Multi-Carrier BO: 14.2 dB	Txp BW Usage: 1776.000 KHz
Uplink Freq: 6175.0 MHz	SFD @ 0 dB/K: -97.1 dBW/m	Txp BW Usage: 4.93%
Downlink Freq: 4000.0 MHz	Input Atten: 6.2	Txp Pow Usage: 3.81%
Buffer Required: 808.00 bits	Polarization: Linear	Power:BW Ratio: 0.77
Delay (E-to-E): 248.17 msec	Transponder BW: 36.0 MHz	Total Txp Usage: 1776.00 KHz
	Beam Center EIRP: 43.7 dBW	Project Number: D.Benning

<u>UPLINK</u>	<u>DOWNLINK</u>
Site ID: VEN	Site ID: PTR
Type: VSAT	Type: VSAT
Location: Caracas, Venezuela	Location: San Juan, Puerto_Rico
Latitude: 10.50 N	Latitude: 18.47 N
Longitude: 66.92 W	Longitude: 66.10 W
Altitude: 909.0 meters	Altitude: 3.0 meters
Azimuth: 114.23	Azimuth: 129.21
Elevation: 61.73	Elevation: 57.68
Polarization: -63.59	Polarization: -47.15
Satellite G/T: -4.00 dB/K	Satellite EIRP: 38.50 dBW
Antenna Diameter: 3.70 meter	Antenna Diameter: 3.80 meter
Antenna Gain: 46.30 dBi	Antenna Gain: 41.80 dBi
Circuit EIRP: 56.13 dBW	Antenna Noise: 21.00 K
HPA Power: 12.74 Watts	LNA Temperature: 20 K
HPA Power: 11.05 dBW	G/T (Clear): 24.2 dB/K
Flange Density: -15.50 dBW/4KHz	G/T (Rain): 23.7 dB/K
FCC Maximum: -2.80 dBW/4KHz	D/L Power Density: -0.1 dBW/4KHz (Max = 6.0)

UPLINK PATH CALCULATIONS

Slant Path Dist:	36438.2 km
Path Loss:	199.5 dB
Spreading Loss:	162.2 dB-m ²
0 Isotherm Ht:	4.9 km
Frequency:	6175.0 MHz
Polarization:	Vertical

INTERFERENCE ANALYSIS

	<u>Uplink</u>	<u>Downlink</u>
Adjacent Sat:	98.1 dB-Hz	92.1 dB-Hz
Cross-Pol:	92.1 dB-Hz	92.1 dB-Hz
Terrestrial:		92.1 dB-Hz
Adjacent Ch:		92.1 dB-Hz
I/No:	91.2 dB-Hz	86.1 dB-Hz

DOWNLINK PATH CALCULATIONS

Slant Path Dist:	36638.0 km
Path Loss:	195.8 dB
Spreading Loss:	162.3 dB-m ²
0 Isotherm Ht:	4.9 km
Frequency:	4000.0 MHz
Polarization:	Vertical

RAIN ANALYSIS

	<u>Uplink</u>	<u>Downlink</u>
Crane Region:	H	G
Availability:	99.9500 %	99.9500 %
Point Rain Rate:	77.0 mm/hr	33.0 mm/hr
Attenuation:	2.5 dB	0.2 dB
Rain Noise:		7.3 K
G/T Degradation:		0.5 dB
Absorbtion:		
U/L Power Control:	0.0 dB	

CARRIER TO NOISE ANALYSIS

	<u>Both Faded</u>	<u>U/L Faded</u>	<u>D/L Faded</u>	<u>No Fading</u>
U/L Thermal:	78.8 dB-Hz	78.8	81.2	81.2
D/L Thermal:	74.4 dB-Hz	75.1	76.9	77.6
System C/No:	72.8 dB-Hz	73.2	75.1	75.5
System C/N:	10.6 dB	11.1	12.9	13.4
System Eb/No:	8.4 dB	8.9	10.7	11.1
Sat Flux Density:	-168.6 dBW/m ²	-168.6	-166.1	-166.1
D/L Pow Density:	-2.6 dBW/4KHz	-2.6	-0.1	-0.1
Carrier Sat EIRP:	18.3 dBW	18.3	20.8	20.8
Carrier BO:	16.7 dB	16.7	14.2	14.2
% Txp Usage:	2.1 %	2.1 %	3.8 %	3.8 %
Link Margin:	0.8 dB	1.3	3.1	3.5
C/N (Uplink):	n/a	n/a	n/a	13.0
C/N (WOD):	n/a	n/a	n/a	15.7

Notes:

Satellite Link Budget Calculation Americom Government Services

<u>CIRCUIT</u>	<u>SATELLITE</u>	<u>PROJECT INFO</u>
Link #: 005a	Satellite: PAS1R-COPOL	Project Name: REDDIG
Information Rate: 1875000 + 0 bps	Orbital Position: 45.0 W	System Engineer: D.Sahu
Availability: 99.9000%	Transponder: C-Band	Contract Length: 60 months
Bit Error Rate: 1.0E-07	Transponder Beam: N/SAM	Contract Phase: 1
Modulation: QPSK	Input Backoff: 5.0 dB	Manufacturer: Comsat
Inner FEC: VITERBI (R-3/4)	Output Backoff: 3.5 dB	Modem Model: LinkWay2000
Outer FEC: REED-SOLOMON (R-216/236)	Multi-Carrier BO: 11.4 dB	Txp BW Usage: 1776.000 KHz
Uplink Freq: 6175.0 MHz	SFD @ 0 dB/K: -97.1 dBW/m	Txp BW Usage: 4.93%
Downlink Freq: 4000.0 MHz	Input Atten: 6.2	Txp Pow Usage: 7.28%
Buffer Required: 808.00 bits	Polarization: Linear	Power:BW Ratio: 1.48
Delay (E-to-E): 245.63 msec	Transponder BW: 36.0 MHz	Total Txp Usage: 2620.30 KHz
	Beam Center EIRP: 43.7 dBW	Project Number: D.Benning

<u>UPLINK</u>	<u>DOWNLINK</u>
Site ID: VEN	Site ID: FRG
Type: VSAT	Type: VSAT
Location: Caracas, Venezuela	Location: Cayenne, Fr_Guyana
Latitude: 10.50 N	Latitude: 4.93 N
Longitude: 66.92 W	Longitude: 52.33 W
Altitude: 909.0 meters	Altitude: 0.0 meters
Azimuth: 114.23	Azimuth: 123.58
Elevation: 61.73	Elevation: 79.63
Polarization: -63.59	Polarization: -55.93
Satellite G/T: -4.00 dB/K	Satellite EIRP: 36.00 dBW
Antenna Diameter: 3.70 meter	Antenna Diameter: 3.70 meter
Antenna Gain: 46.30 dBi	Antenna Gain: 42.50 dBi
Circuit EIRP: 58.94 dBW	Antenna Noise: 21.00 K
HPA Power: 24.33 Watts	LNA Temperature: 40 K
HPA Power: 13.86 dBW	G/T (Clear): 23.6 dB/K
Flange Density: -12.69 dBW/4KHz	G/T (Rain): 22.7 dB/K
FCC Maximum: -2.80 dBW/4KHz	D/L Power Density: 2.7 dBW/4KHz (Max = 6.0)

UPLINK PATH CALCULATIONS

Slant Path Dist:	36438.2 km
Path Loss:	199.5 dB
Spreading Loss:	162.2 dB-m ²
0 Isotherm Ht:	4.9 km
Frequency:	6175.0 MHz
Polarization:	Vertical

INTERFERENCE ANALYSIS

	<u>Uplink</u>	<u>Downlink</u>
Adjacent Sat:	98.1 dB-Hz	92.1 dB-Hz
Cross-Pol:	92.1 dB-Hz	92.1 dB-Hz
Terrestrial:		92.1 dB-Hz
Adjacent Ch:		92.1 dB-Hz
I/No:	91.2 dB-Hz	86.1 dB-Hz

DOWNLINK PATH CALCULATIONS

Slant Path Dist:	35874.8 km
Path Loss:	195.6 dB
Spreading Loss:	162.1 dB-m ²
0 Isotherm Ht:	4.9 km
Frequency:	4000.0 MHz
Polarization:	Vertical

RAIN ANALYSIS

	<u>Uplink</u>	<u>Downlink</u>
Crane Region:	H	H
Availability:	99.9500 %	99.9500 %
Point Rain Rate:	77.0 mm/hr	77.0 mm/hr
Attenuation:	2.5 dB	0.4 dB
Rain Noise:		18.4 K
G/T Degradation:		0.9 dB
Absorbtion:		
U/L Power Control:	0.0 dB	

CARRIER TO NOISE ANALYSIS

	<u>Both Faded</u>	<u>U/L Faded</u>	<u>D/L Faded</u>	<u>No Fading</u>
U/L Thermal:	81.6 dB-Hz	81.6	84.1	84.1
D/L Thermal:	73.7 dB-Hz	75.0	76.2	77.5
System C/No:	72.8 dB-Hz	73.8	75.1	76.1
System C/N:	10.6 dB	11.7	12.9	13.9
System Eb/No:	8.4 dB	9.5	10.7	11.7
Sat Flux Density:	-165.8 dBW/m ²	-165.8	-163.3	-163.3
D/L Pow Density:	0.2 dBW/4KHz	0.2	2.7	2.7
Carrier Sat EIRP:	18.6 dBW	18.6	21.1	21.1
Carrier BO:	13.9 dB	13.9	11.4	11.4
% Txp Usage:	4.1 %	4.1 %	7.3 %	7.3 %
Link Margin:	0.8 dB	1.9	3.1	4.1
C/N (Uplink):	n/a	n/a	n/a	13.8
C/N (WOD):	n/a	n/a	n/a	16.9

Notes:

Satellite Link Budget Calculation Americom Government Services

<u>CIRCUIT</u>	<u>SATELLITE</u>	<u>PROJECT INFO</u>
Link #: 007a	Satellite: PAS1R-COPOL	Project Name: REDDIG
Information Rate: 1875000 + 0 bps	Orbital Position: 45.0 W	System Engineer: D.Sahu
Availability: 99.9000%	Transponder: C-Band	Contract Length: 60 months
Bit Error Rate: 1.0E-07	Transponder Beam: N/SAM	Contract Phase: 1
Modulation: QPSK	Input Backoff: 5.0 dB	Manufacturer: Comsat
Inner FEC: VITERBI (R-3/4)	Output Backoff: 3.5 dB	Modem Model: LinkWay2000
Outer FEC: REED-SOLOMON (R-216/236)	Multi-Carrier BO: 16.8 dB	Txp BW Usage: 1776.000 KHz
Uplink Freq: 6175.0 MHz	SFD @ 0 dB/K: -97.1 dBW/m	Txp BW Usage: 4.93%
Downlink Freq: 4000.0 MHz	Input Atten: 6.2	Txp Pow Usage: 2.08%
Buffer Required: 808.00 bits	Polarization: Linear	Power:BW Ratio: 0.42
Delay (E-to-E): 254.70 msec	Transponder BW: 36.0 MHz	Total Txp Usage: 1776.00 KHz
	Beam Center EIRP: 43.7 dBW	Project Number: D.Benning

<u>UPLINK</u>	<u>DOWNLINK</u>
Site ID: HON	Site ID: JAM
Type: VSAT	Type: VSAT
Location: Tegucigalpa, Honduras	Location: Kingston, Jamaica
Latitude: 14.05 N	Latitude: 17.93 N
Longitude: 87.22 W	Longitude: 76.78 W
Altitude: 3260.0 meters	Altitude: 30.0 meters
Azimuth: 104.88	Azimuth: 116.29
Elevation: 39.22	Elevation: 48.24
Polarization: -69.57	Polarization: -58.43
Satellite G/T: -1.00 dB/K	Satellite EIRP: 41.00 dBW
Antenna Diameter: 3.80 meter	Antenna Diameter: 3.80 meter
Antenna Gain: 46.20 dBi	Antenna Gain: 41.80 dBi
Circuit EIRP: 50.83 dBW	Antenna Noise: 21.00 K
HPA Power: 3.84 Watts	LNA Temperature: 20 K
HPA Power: 5.85 dBW	G/T (Clear): 24.2 dB/K
Flange Density: -20.71 dBW/4KHz	G/T (Rain): 23.6 dB/K
FCC Maximum: -2.80 dBW/4KHz	D/L Power Density: -2.8 dBW/4KHz (Max = 6.0)

UPLINK PATH CALCULATIONS

Slant Path Dist:	37839.4 km
Path Loss:	199.8 dB
Spreading Loss:	162.6 dB-m ²
0 Isotherm Ht:	4.9 km
Frequency:	6175.0 MHz
Polarization:	Vertical

INTERFERENCE ANALYSIS

	<u>Uplink</u>	<u>Downlink</u>
Adjacent Sat:	98.1 dB-Hz	92.1 dB-Hz
Cross-Pol:	92.1 dB-Hz	92.1 dB-Hz
Terrestrial:		92.1 dB-Hz
Adjacent Ch:		92.1 dB-Hz
I/No:	91.2 dB-Hz	86.1 dB-Hz

DOWNLINK PATH CALCULATIONS

Slant Path Dist:	37193.2 km
Path Loss:	195.9 dB
Spreading Loss:	162.4 dB-m ²
0 Isotherm Ht:	4.9 km
Frequency:	4000.0 MHz
Polarization:	Vertical

RAIN ANALYSIS

	<u>Uplink</u>	<u>Downlink</u>
Crane Region:	H	G
Availability:	99.9500 %	99.9500 %
Point Rain Rate:	77.0 mm/hr	33.0 mm/hr
Attenuation:	1.4 dB	0.2 dB
Rain Noise:		7.9 K
G/T Degradation:		0.6 dB
Absorbtion:		
U/L Power Control:	0.0 dB	

CARRIER TO NOISE ANALYSIS

	<u>Both Faded</u>	<u>U/L Faded</u>	<u>D/L Faded</u>	<u>No Fading</u>
U/L Thermal:	77.2 dB-Hz	77.2	78.6	78.6
D/L Thermal:	75.1 dB-Hz	75.9	76.5	77.3
System C/No:	72.8 dB-Hz	73.2	74.1	74.5
System C/N:	10.6 dB	11.1	11.9	12.3
System Eb/No:	8.4 dB	8.8	9.7	10.1
Sat Flux Density:	-173.1 dBW/m ²	-173.1	-171.7	-171.7
D/L Pow Density:	-4.2 dBW/4KHz	-4.2	-2.8	-2.8
Carrier Sat EIRP:	19.3 dBW	19.3	20.7	20.7
Carrier BO:	18.2 dB	18.2	16.8	16.8
% Txp Usage:	1.5 %	1.5 %	2.1 %	2.1 %
Link Margin:	0.8 dB	1.2	2.1	2.5
C/N (Uplink):	n/a	n/a	n/a	12.2
C/N (WOD):	n/a	n/a	n/a	14.3

Notes:

Satellite Link Budget Calculation Americom Government Services

CIRCUIT

Link #: 008a
 Information Rate: 1875000 + 0 bps
 Availability: 99.9000%
 Bit Error Rate: 1.0E-07
 Modulation: QPSK
 Inner FEC: VITERBI (R-3/4)
 Outer FEC: REED-SOLOMON (R-216/236)
 Uplink Freq: 6175.0 MHz
 Downlink Freq: 4000.0 MHz
 Buffer Required: 808.00 bits
 Delay (E-to-E): 254.44 msec

SATELLITE

Satellite: PAS1R-COPOL
 Orbital Position: 45.0 W
 Transponder: C-Band
 Transponder Beam: N/SAM
 Input Backoff: 5.0 dB
 Output Backoff: 3.5 dB
 Multi-Carrier BO: 16.7 dB
 SFD @ 0 dB/K: -97.1 dBW/m
 Input Atten: 6.2
 Polarization: Linear
 Transponder BW: 36.0 MHz
 Beam Center EIRP: 43.7 dBW

PROJECT INFO

Project Name: REDDIG
 System Engineer: D.Sahu
 Contract Length: 60 months
 Contract Phase: 1
 Manufacturer: Comsat
 Modem Model: LinkWay2000
 Txp BW Usage: 1776.000 KHz
 Txp BW Usage: 4.93%
 Txp Pow Usage: 2.16%
 Power:BW Ratio: 0.44
 Total Txp Usage: 1776.00 KHz
 Project Number: D.Benning

UPLINK

Site ID: HON
 Type: VSAT
 Location: Tegucigalpa, Honduras
 Latitude: 14.05 N
 Longitude: 87.22 W
 Altitude: 3260.0 meters
 Azimuth: 104.88
 Elevation: 39.22
 Polarization: -69.57
 Satellite G/T: -1.00 dB/K
 Antenna Diameter: 3.80 meter
 Antenna Gain: 46.20 dBi
 Circuit EIRP: 51.00 dBW
 HPA Power: 4.00 Watts
 HPA Power: 6.02 dBW
 Flange Density: -20.54 dBW/4KHz
 FCC Maximum: -2.80 dBW/4KHz

DOWNLINK

Site ID: ECU
 Type: VSAT
 Location: Guayaquil, Ecuador
 Latitude: 2.17 S
 Longitude: 79.90 W
 Altitude: 46.0 meters
 Azimuth: 86.92
 Elevation: 49.39
 Polarization: 86.22
 Satellite EIRP: 42.00 dBW
 Antenna Diameter: 3.70 meter
 Antenna Gain: 42.50 dBi
 Antenna Noise: 21.00 K
 LNA Temperature: 40 K
 G/T (Clear): 23.6 dB/K
 G/T (Rain): 22.6 dB/K
 D/L Power Density: -2.6 dBW/4KHz (Max = 6.0)

UPLINK PATH CALCULATIONS

Slant Path Dist: 37839.4 km
 Path Loss: 199.8 dB
 Spreading Loss: 162.6 dB-m²
 0 Isotherm Ht: 4.9 km
 Frequency: 6175.0 MHz
 Polarization: Vertical

INTERFERENCE ANALYSIS

	<u>Uplink</u>	<u>Downlink</u>
Adjacent Sat:	98.1 dB-Hz	92.1 dB-Hz
Cross-Pol:	92.1 dB-Hz	92.1 dB-Hz
Terrestrial:		92.1 dB-Hz
Adjacent Ch:		92.1 dB-Hz
I/No:	91.2 dB-Hz	86.1 dB-Hz

DOWNLINK PATH CALCULATIONS

Slant Path Dist: 37117.1 km
 Path Loss: 195.9 dB
 Spreading Loss: 162.4 dB-m²
 0 Isotherm Ht: 4.9 km
 Frequency: 4000.0 MHz
 Polarization: Vertical

RAIN ANALYSIS

	<u>Uplink</u>	<u>Downlink</u>
Crane Region:	H	H
Availability:	99.9500 %	99.9500 %
Point Rain Rate:	77.0 mm/hr	77.0 mm/hr
Attenuation:	1.4 dB	0.5 dB
Rain Noise:		20.6 K
G/T Degradation:		1.0 dB
Absorbtion:		
U/L Power Control:	0.0 dB	

CARRIER TO NOISE ANALYSIS

	<u>Both Faded</u>	<u>U/L Faded</u>	<u>D/L Faded</u>	<u>No Fading</u>
U/L Thermal:	77.4 dB-Hz	77.4	78.8	78.8
D/L Thermal:	75.0 dB-Hz	76.5	76.4	77.9
System C/No:	72.8 dB-Hz	73.6	74.1	74.9
System C/N:	10.6 dB	11.4	11.9	12.7
System Eb/No:	8.4 dB	9.2	9.7	10.5
Sat Flux Density:	-173.0 dBW/m ²	-173.0	-171.6	-171.6
D/L Pow Density:	-4.0 dBW/4KHz	-4.0	-2.6	-2.6
Carrier Sat EIRP:	20.4 dBW	20.4	21.8	21.8
Carrier BO:	18.1 dB	18.1	16.7	16.7
% Txp Usage:	1.6 %	1.6 %	2.2 %	2.2 %
Link Margin:	0.8 dB	1.6	2.1	2.9
C/N (Uplink):	n/a	n/a	n/a	12.9
C/N (WOD):	n/a	n/a	n/a	14.7

Notes:

Earth Station Power Report Americom Government Services

Project: REDDIG
Site ID: HON
Site Name: Tegucigalpa **Antenna Size:** 3.80 m
Site Type: VSAT **LNA:** 20 K
State/Country: na , Honduras **G/T (clear sky):** 24.11 dB/K
Crane Rain Region: H

Date: Wed Oct 03 06:27:03 2007

<u>Circuit</u>	<u>Rx Site</u>	<u>Information Rate</u>	<u>Inner/Outer Code</u>	<u>Eb/No</u>	<u>Watts</u>	<u>U/L Rain B.O.</u>	<u>Leased Txp</u>	<u>Power:BW</u>
007a	JAM	1875000.0 bps	0.750/0.915	7.6 dB	3.65 W	0.00 dB	1776.0 KHz	0.42
008a	ECU	1875000.0 bps	0.750/0.915	7.6 dB	3.80 W	0.00 dB	1776.0 KHz	0.44

Power Required for circuits: 7.4 Watts
Additional Power Required for ULPC: -0.0 Watts
Total Power Required: 7.4 Watts

Number of U/L Carriers: 2
IM Backoff (TWTA/SSPA): 5.0/3.0 dB
Required Minimum HPA: TWTA: 23.6 Watts SSPA: 14.9 Watts

Earth Station Power Report *Americom Government Services*

Project: REDDIG
Site ID: JAM
Site Name: Kingston Antenna Size: 3.80 m
Site Type: VSAT LNA: 20 K
State/Country: na , Jamaica G/T (clear sky): 24.17 dB/K
Crane Rain Region: G

Date: Wed Oct 03 06:27:03 2007

<u>Circuit</u>	<u>Rx Site</u>	<u>Information Rate</u>	<u>Inner/Outer Code</u>	<u>Eb/No</u>	<u>Watts</u>	<u>U/L Rain B.O.</u>	<u>Leased Txp</u>	<u>Power:BW</u>
----------------	----------------	-------------------------	-------------------------	--------------	--------------	----------------------	-------------------	-----------------

Earth Station Power Report *Americom Government Services*

Project:	REDDIG								
Site ID:	PAN								Date: Wed Oct 03 06:27:03 2007
Site Name:	Panama City	Antenna Size:	3.80 m						
Site Type:	VSAT	LNA:	20 K						
State/Country:	na , Panama	G/T (clear sky):	24.18 dB/K						
Crane Rain Region:	H								

<u>Circuit</u>	<u>Rx Site</u>	<u>Information Rate</u>	<u>Inner/Outer Code</u>	<u>Eb/No</u>	<u>Watts</u>	<u>U/L Rain B.O.</u>	<u>Leased Txp</u>	<u>Power:BW</u>
----------------	----------------	-------------------------	-------------------------	--------------	--------------	----------------------	-------------------	-----------------

Earth Station Power Report *Americom Government Services*

Project:	REDDIG								
Site ID:	CUR								Date: Wed Oct 03 06:27:03 2007
Site Name:	Willenstad	Antenna Size:	3.80 m						
Site Type:	VSAT	LNA:	20 K						
State/Country:	na , Curacao	G/T (clear sky):	24.20 dBi/K						
Crane Rain Region:	G								

<u>Circuit</u>	<u>Rx Site</u>	<u>Information Rate</u>	<u>Inner/Outer Code</u>	<u>Eb/No</u>	<u>Watts</u>	<u>U/L Rain B.O.</u>	<u>Leased Txp</u>	<u>Power:BW</u>
----------------	----------------	-------------------------	-------------------------	--------------	--------------	----------------------	-------------------	-----------------

Earth Station Power Report *Americom Government Services*

Project:	REDDIG								
Site ID:	ARU								Date: Wed Oct 03 06:27:03 2007
Site Name:	Oranjestad	Antenna Size:	3.80 m						
Site Type:	VSAT	LNA:	20 K						
State/Country:	na , Aruba	G/T (clear sky):	24.20 dBi/K						
Crane Rain Region:	G								

<u>Circuit</u>	<u>Rx Site</u>	<u>Information Rate</u>	<u>Inner/Outer Code</u>	<u>Eb/No</u>	<u>Watts</u>	<u>U/L Rain B.O.</u>	<u>Leased Txp</u>	<u>Power:BW</u>
----------------	----------------	-------------------------	-------------------------	--------------	--------------	----------------------	-------------------	-----------------

Earth Station Power Report **Americom Government Services**

Project: REDDIG
Site ID: PTR
Site Name: San Juan Antenna Size: 3.80 m
Site Type: VSAT LNA: 20 K
State/Country: na , Puerto_Rico G/T (clear sky): 24.20 dBi/K
Crane Rain Region: G

Date: Wed Oct 03 06:27:03 2007

<u>Circuit</u>	<u>Rx Site</u>	<u>Information Rate</u>	<u>Inner/Outer Code</u>	<u>Eb/No</u>	<u>Watts</u>	<u>U/L Rain B.O.</u>	<u>Leased Txp</u>	<u>Power:BW</u>
----------------	----------------	-------------------------	-------------------------	--------------	--------------	----------------------	-------------------	-----------------

Earth Station Power Report Americom Government Services

Project: REDDIG
Site ID: COL
Site Name: Bogota Antenna Size: 3.70 m
Site Type: VSAT LNA: 40 K
State/Country: na , Columbia G/T (clear sky): 23.60 dBi/K
Crane Rain Region: H

Date: Wed Oct 03 06:27:03 2007

<u>Circuit</u>	<u>Rx Site</u>	<u>Information Rate</u>	<u>Inner/Outer Code</u>	<u>Eb/No</u>	<u>Watts</u>	<u>U/L Rain B.O.</u>	<u>Leased Txp</u>	<u>Power:BW</u>
001a	CUR	1875000.0 bps	0.750/0.915	7.6 dB	3.51 W	0.00 dB	1776.0 KHz	0.55
002a	FRG	1875000.0 bps	0.750/0.915	7.6 dB	10.62 W	0.00 dB	2970.0 KHz	1.67

Power Required for circuits: 14.1 Watts
Additional Power Required for ULPC: -0.0 Watts
Total Power Required: 14.1 Watts

Number of U/L Carriers: 2
IM Backoff (TWTA/SSPA): 5.0/3.0 dB
Required Minimum HPA: TWTA: 44.7 Watts SSPA: 28.2 Watts

Earth Station Power Report Americom Government Services

Project: REDDIG
Site ID: VEN
Site Name: Caracas
Site Type: VSAT
State/Country: na , Venezuela
Crane Rain Region: H

Antenna Size: 3.70 m
LNA: 40 K
G/T (clear sky): 23.61 dBi/K

Date: Wed Oct 03 06:27:03 2007

<u>Circuit</u>	<u>Rx Site</u>	<u>Information Rate</u>	<u>Inner/Outer Code</u>	<u>Eb/No</u>	<u>Watts</u>	<u>U/L Rain B.O.</u>	<u>Leased Txp</u>	<u>Power:BW</u>
004a	PTR	1875000.0 bps	0.750/0.915	7.6 dB	12.12 W	0.00 dB	1776.0 KHz	0.77
005a	FRG	1875000.0 bps	0.750/0.915	7.6 dB	23.14 W	0.00 dB	2620.3 KHz	1.48

Power Required for circuits: 35.3 Watts
Additional Power Required for ULPC: 0.0 Watts
Total Power Required: 35.3 Watts

Number of U/L Carriers: 2
IM Backoff (TWTA/SSPA): 5.0/3.0 dB
Required Minimum HPA: TWTA: 111.5 Watts SSPA: 70.3 Watts

Earth Station Power Report *Americom Government Services*

Project:	REDDIG								
Site ID:	ECU								Date: Wed Oct 03 06:27:03 2007
Site Name:	Guayaquil	Antenna Size:	3.70 m						
Site Type:	VSAT	LNA:	40 K						
State/Country:	na , Ecuador	G/T (clear sky):	23.59 dB/K						
Crane Rain Region:	H								

<u>Circuit</u>	<u>Rx Site</u>	<u>Information Rate</u>	<u>Inner/Outer Code</u>	<u>Eb/No</u>	<u>Watts</u>	<u>U/L Rain B.O.</u>	<u>Leased Txp</u>	<u>Power:BW</u>
----------------	----------------	-------------------------	-------------------------	--------------	--------------	----------------------	-------------------	-----------------

Earth Station Power Report *Americom Government Services*

Project: REDDIG
Site ID: FRG
Site Name: Cayenne Antenna Size: 3.70 m
Site Type: VSAT LNA: 40 K
State/Country: na , Fr_Guyana G/T (clear sky): 23.63 dBi/K
Crane Rain Region: H

Date: Wed Oct 03 06:27:03 2007

<u>Circuit</u>	<u>Rx Site</u>	<u>Information Rate</u>	<u>Inner/Outer Code</u>	<u>Eb/No</u>	<u>Watts</u>	<u>U/L Rain B.O.</u>	<u>Leased Txp</u>	<u>Power:BW</u>
----------------	----------------	-------------------------	-------------------------	--------------	--------------	----------------------	-------------------	-----------------

Earth Station Power Report *Americom Government Services*

Project:	REDDIG								
Site ID:	MIA								Date: Wed Oct 03 06:27:03 2007
Site Name:	Miami	Antenna Size:	7.00 m						
Site Type:	Hub	LNA:	35 K						
State/Country:	FL , USA	G/T (clear sky):	29.52 dB/K						
Crane Rain Region:	E								

<u>Circuit</u>	<u>Rx Site</u>	<u>Information Rate</u>	<u>Inner/Outer Code</u>	<u>Eb/No</u>	<u>Watts</u>	<u>U/L Rain B.O.</u>	<u>Leased Txp</u>	<u>Power:BW</u>
----------------	----------------	-------------------------	-------------------------	--------------	--------------	----------------------	-------------------	-----------------

Earth Station Summary Report Americom Government Services

Project: REDDIG (D.Benning)

10/3/2007 06: 26: 57 am

Satellite: PAS1R-COPOL @ 45.0 W (36 MHz)

SITE ID	Type	Location	Latitude	Longitude	Elevation	Azimuth	Pol.	Crane	Decl.	Antenna	G/T(clear)	Slant Path	Delay	Visible Satellites		
														LNA Temp	East Limit	West Limit
HON	VSAT	Tegucigalpa, Honduras	14.05 N	87.22 W	39.22	104.88	-69.57	H	1.57 E	3.80 m	24.11 dB/K	37839.4 km	126.2 ms	20.0 K	353.8 E	191.8 E
JAM	VSAT	Kingston, Jamaica	17.93 N	76.78 W	48.24	116.29	-58.43	G	-5.83 E	3.80 m	24.17 dB/K	37193.2 km	124.1 ms	20.0 K	364.1 E	202.4 E
PAN	VSAT	Panama City, Panama	8.98 N	79.22 W	49.09	102.85	-74.30	H	-2.46 E	3.80 m	24.18 dB/K	37136.8 km	123.9 ms	20.0 K	362.0 E	199.6 E
CUR	VSAT	Willenstad, Curacao	12.20 N	68.97 W	58.81	115.28	-61.98	G	-9.88 E	3.80 m	24.20 dB/K	36578.8 km	122.0 ms	20.0 K	372.1 E	209.9 E
ARU	VSAT	Oranjestad, Aruba	12.50 N	70.02 W	57.60	114.74	-62.33	G	-9.27 E	3.80 m	24.20 dB/K	36640.9 km	122.2 ms	20.0 K	371.1 E	208.9 E
PTR	VSAT	San Juan, Puerto_Rico	18.47 N	66.10 W	57.68	129.21	-47.15	G	-12.45 E	3.80 m	24.20 dB/K	36638.0 km	122.2 ms	20.0 K	374.7 E	213.1 E
COL	VSAT	Bogota, Columbia	4.63 N	74.08 W	55.70	98.21	-80.53	H	-5.15 E	3.70 m	23.60 dB/K	36742.0 km	122.6 ms	40.0 K	367.2 E	204.6 E
VEN	VSAT	Caracas, Venezuela	10.50 N	66.92 W	61.73	114.23	-63.59	H	-10.90 E	3.70 m	23.61 dB/K	36438.2 km	121.6 ms	40.0 K	374.2 E	211.9 E
ECU	VSAT	Guayaquil, Ecuador	2.17 S	79.90 W	49.39	86.92	86.22	H	0.31 E	3.70 m	23.59 dB/K	37117.1 km	123.8 ms	40.0 K	361.4 E	198.8 E
FRG	VSAT	Cayenne, Fr_Guyana	4.93 N	52.33 W	79.63	123.58	-55.93	H	-17.77 E	3.70 m	23.63 dB/K	35874.8 km	119.7 ms	40.0 K	388.9 E	226.4 E
MIA	Hub	Miami, USA	25.80 N	80.30 W	40.80	121.44	-50.09	E	-5.01 E	7.00 m	29.52 dB/K	37722.3 km	125.8 ms	35.0 K	360.0 E	199.4 E

	<u>Minimum</u>	<u>Average</u>	<u>Maximum</u>
Antenna Elevation Angle [degrees]:	39.2 (HON)	54.4	79.6 (FRG)
Delay from E/S to Satellite [msec]:	119.7 (FRG)	123.1	126.2 (HON)
Slant Path Distance from E/S to Satellite [km]:	35874.8 (FRG)	36902.0	37839.4 (HON)
Number of E/S's with Elevation Angle <= 5:	0		
Number of E/S's with 5 < Elevation Angle <= 10:	0		
Number of E/S's with 10 < Elevation Angle <= 20:	0		
Number of E/S's with Elevation Angle > 20:	11		

Note: Visible satellite arc based on elevation angle of 5 degrees or greater

Attachment B:

- 1. Block Diagram REDDIG node at MEVA II site**
- 2. Block Diagram MEVA II node at REDDIG site**

CONFIDENTIAL

Use, duplication and disclosure of the information contained on this page is subject to the restrictions contained in the CONFIDENTIAL NOTICE on the title (first) page of this proposal.

REVISION HISTORY				
ZONE	REV	DESCRIPTION	DATE	Revised By
1	B	Added Combiners & Dividers	09/29/07	EFM
1	C	Removed One MEVA II LinkWay	10/15/07	EFM

Block Diagram MEVA II Node at REDDIG Site

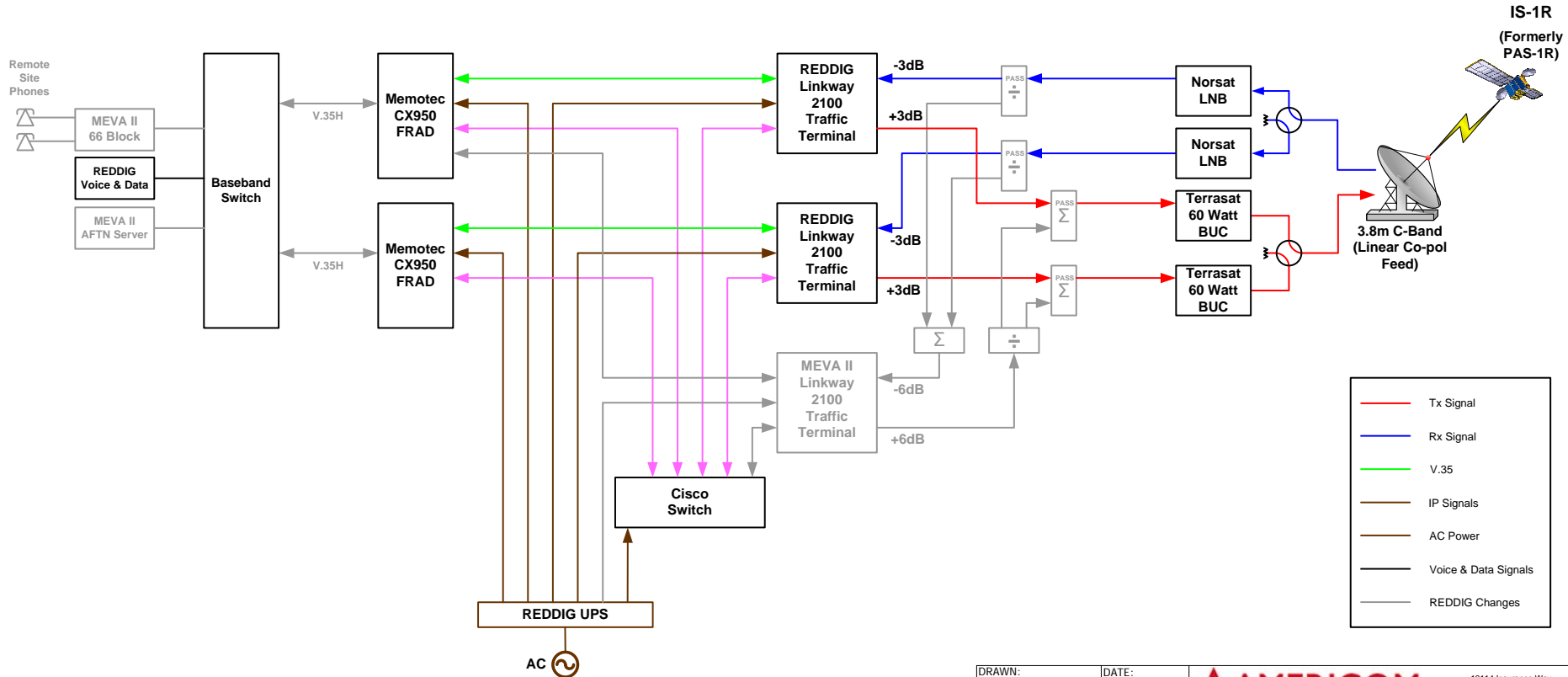

DRAWN: DS	DATE: 09/29/2007		12114 Insurance Way Hagerstown, MD 21740 (301) 797-5093 www.americom-gs.com	
CHECKED:	DATE:		TITLE	
MFG:	DATE:		Block Diagram Remote MEVA II/REDDIG	
SIZE: B	CAGE CODE: 1WJY6	DWG NO:	REV: C	
SCALE:			SHEET 1 OF 1	

REVISION HISTORY				
ZONE	REV	DESCRIPTION	DATE	APPROVED
1	B	Added Combiners & Dividers	09/30/07	EFM

Block Diagram REDDIG Node at MEVA II Site

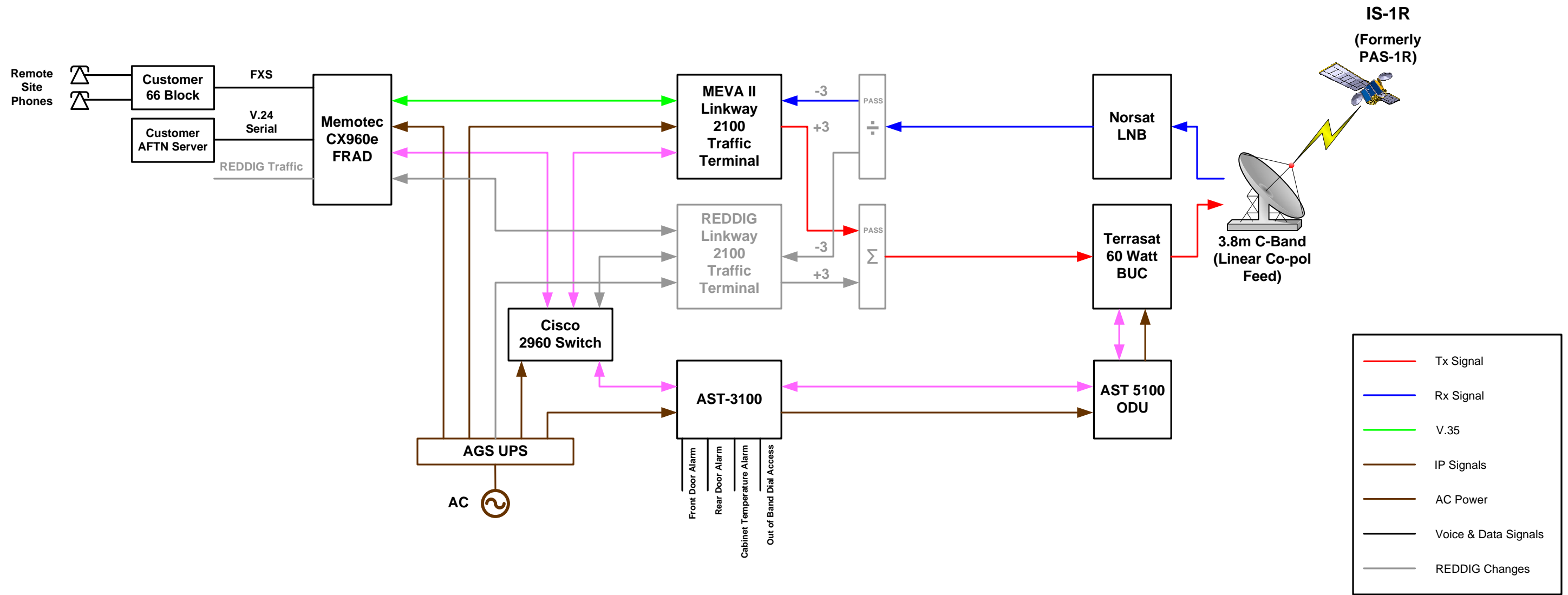

DRAWN: DS	DATE: 09/30/2007	 <p>12114 Insurance Way Hagerstown, MD 21740 (301) 797-5093 www.americom-gs.com</p>	
CHECKED:	DATE:		
MFG:	DATE:		
TITLE		Block Diagram Remote REDDIG @ MEVA II	
SIZE B	CAGE CODE 1WJY6	DWG NO	REV B
SCALE	SHEET 1 OF 1		

MEVAII/REDDIG Interconnect Network

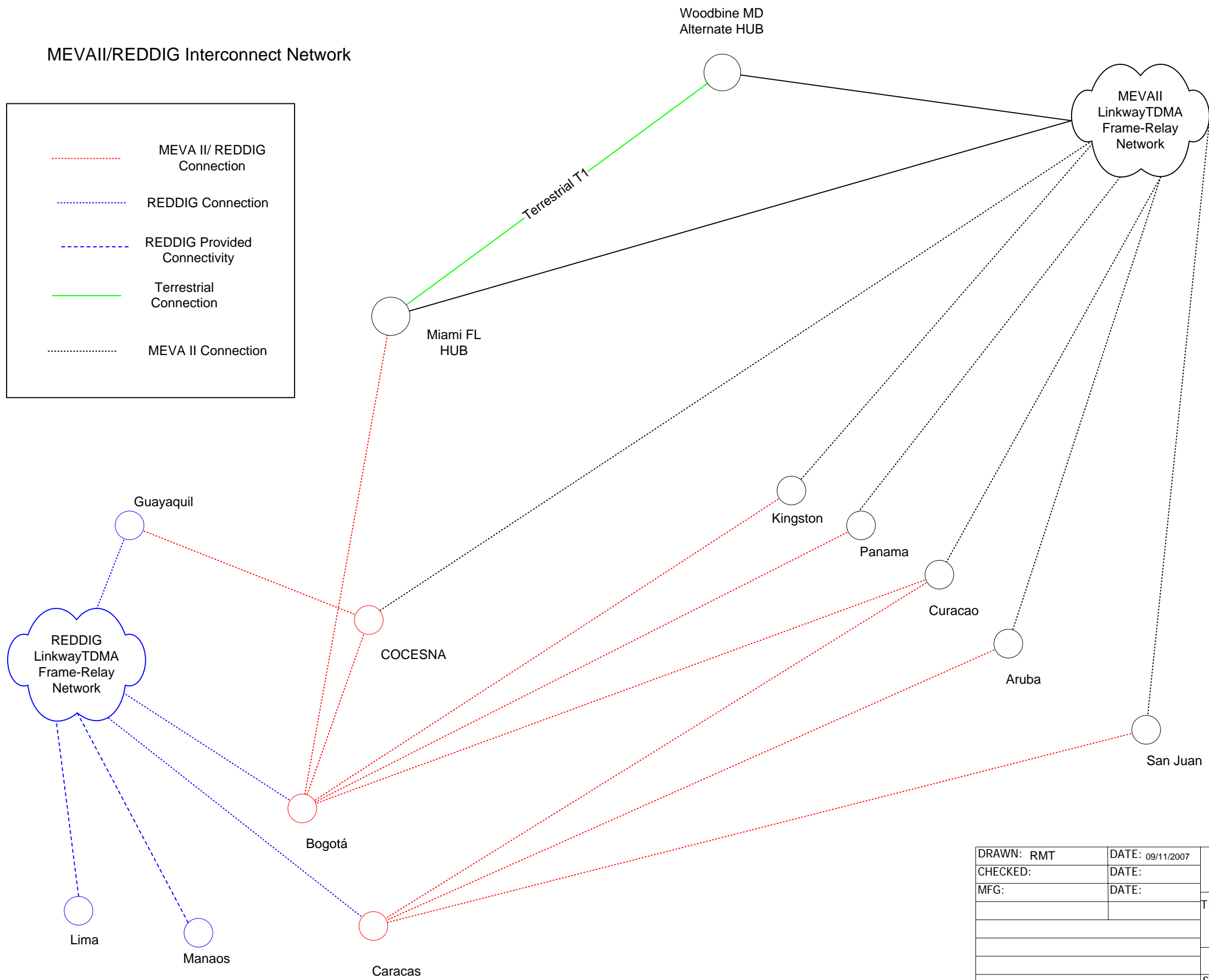
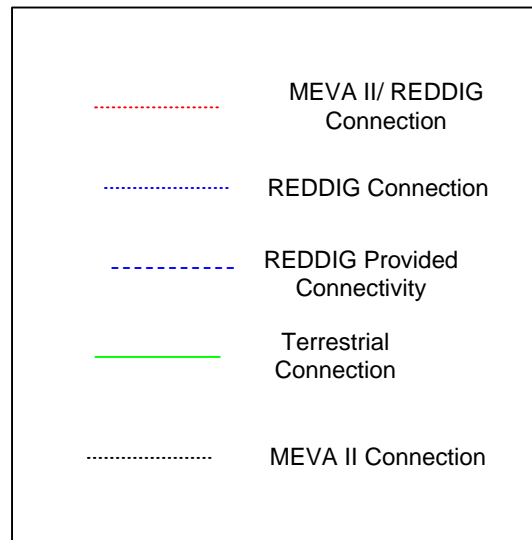

DRAWN: RMT	DATE: 09/11/2007			12114 Insurance Way Hagerstown, MD 21740 (301) 797-5001 www.americom-gs.com	
CHECKED:	DATE:			TITLE	
MFG:	DATE:	SIZE	CAGE CODE	DWG NO	REV
		B	1WJY6		2
		SCALE			SHEET 1 OF 1

Attachment C:

AGS MEVA II – REDDIG Interconnection Implementation Schedule

CONFIDENTIAL

Use, duplication and disclosure of the information contained on this page is subject to the restrictions contained in the CONFIDENTIAL NOTICE on the title (first) page of this proposal.

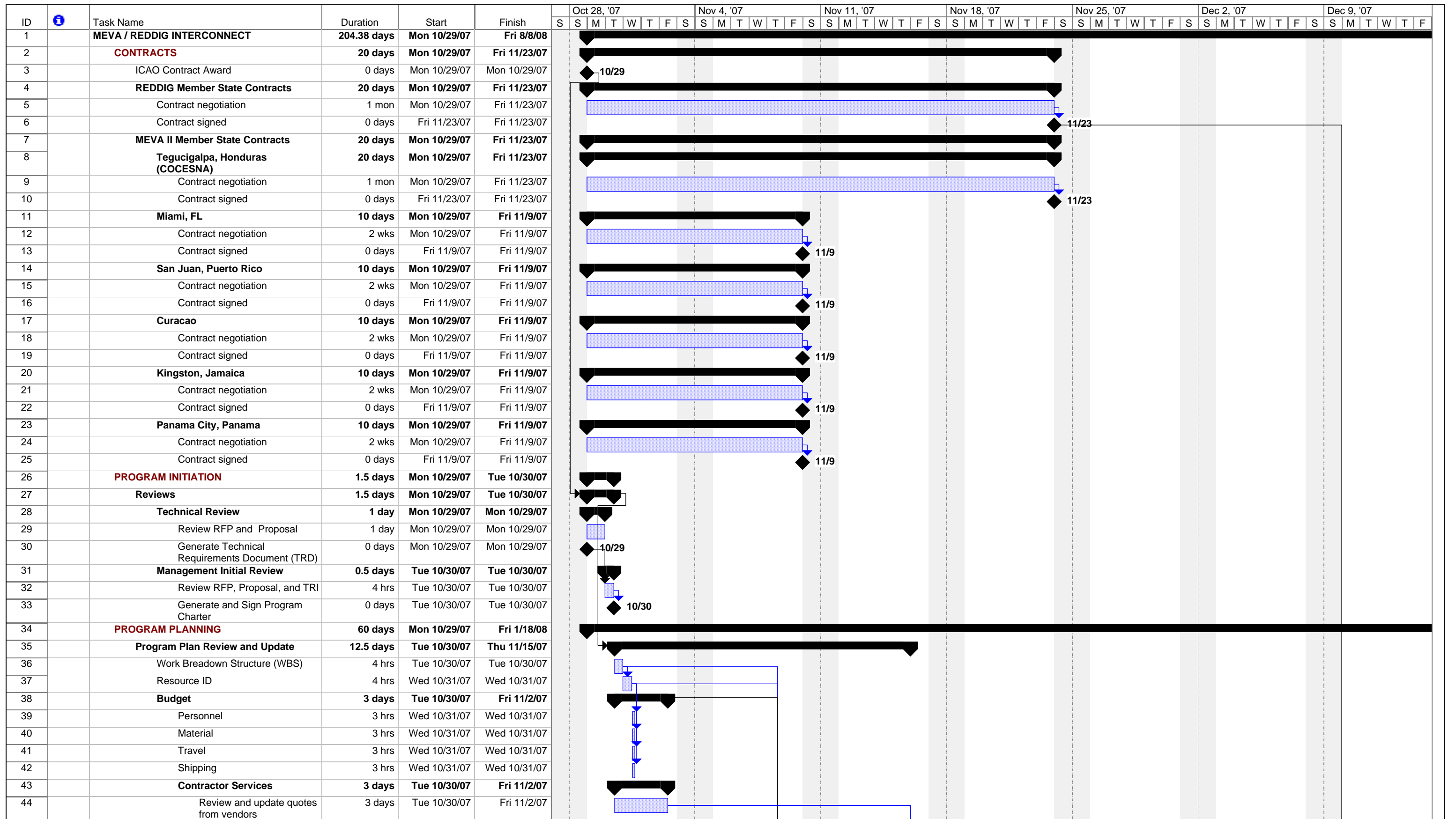

Project: MEVA REDDIG INTERCONN
Date: Fri 10/19/07

Task: [Progress bar] Progress
Split: [Dotted bar] Milestone

[Summary bar] Summary
[Project Summary bar] Project Summary

[External Tasks bar] External Tasks
[External Milestone bar] External Milestone

[Deadline bar] Deadline

Page 1

ID	Task Name	Duration	Start	Finish	Oct 28, '07							Nov 4, '07							Nov 11, '07							Nov 18, '07							Nov 25, '07							Dec 2, '07							Dec 9, '07						
					S	S	M	T	W	T	F	S	S	M	T	W	T	F	S	S	M	T	W	T	F	S	S	M	T	W	T	F	S	S	M	T	W	T	F	S	S	M	T	W	T	F	S	S	M	T	W	T	F
45	Supporting Plans and Docs	0.38 days	Tue 10/30/07	Tue 10/30/07																																																	
46	Subcontract / Vendor Mgmt Plai	1 hr	Tue 10/30/07	Tue 10/30/07																																																	
47	Comm Plan	1 hr	Tue 10/30/07	Tue 10/30/07																																																	
48	Risk Plan	3 hrs	Tue 10/30/07	Tue 10/30/07																																																	
49	Change Mgmt Plan	1 hr	Tue 10/30/07	Tue 10/30/07																																																	
50	Escalation List	0.5 hrs	Tue 10/30/07	Tue 10/30/07																																																	
51	Program Plan Complete	0 days	Thu 11/8/07	Thu 11/8/07																																																	
52	AGS Management approval of Program Plan	0 days	Thu 11/8/07	Thu 11/8/07																																																	
53	Customer review of Program Plan	5 days	Fri 11/9/07	Thu 11/15/07																																																	
54	Customer approval of Program Plan	0 days	Thu 11/15/07	Thu 11/15/07																																																	
55	Engineering	10 days	Mon 10/29/07	Fri 11/9/07																																																	
56	Develop Engineering Documentation Package	0 days	Tue 11/6/07	Tue 11/6/07																																																	
57	Finalize engineering solution	2 days	Wed 11/7/07	Thu 11/8/07																																																	
58	Vendor SOWs	2 days	Mon 10/29/07	Tue 10/30/07																																																	
59	Develop integration / Test SOW Technical Requirements	1 day	Mon 10/29/07	Mon 10/29/07																																																	
60	Develop Installation SOW Technical Requirements	1 day	Tue 10/30/07	Tue 10/30/07																																																	
61	Installation and Acceptance Plan	10 days	Mon 10/29/07	Fri 11/9/07																																																	
62	AGS develop overall Installation and Acceptance	1 wk	Mon 10/29/07	Fri 11/2/07																																																	
63	Customer review overall Installation and Acceptance	5 days	Mon 11/5/07	Fri 11/9/07																																																	
64	Customer approve Installation and Acceptance Plan	0 days	Fri 11/9/07	Fri 11/9/07																																																	
65	Administrative	3 days	Fri 11/9/07	Tue 11/13/07																																																	
66	Internal Order Request (IOR)	3 days	Fri 11/9/07	Tue 11/13/07																																																	
67	Submit IOR for budget	1 day	Fri 11/9/07	Fri 11/9/07																																																	
68	IOR Approved	1 day	Mon 11/12/07	Mon 11/12/07																																																	
69	SAP Project # Assigned	1 day	Tue 11/13/07	Tue 11/13/07																																																	
70	Siebel	1 day	Fri 11/9/07	Fri 11/9/07																																																	
71	Procurement	46 days	Fri 11/16/07	Fri 1/18/08																																																	
72	ViaSat	6.13 days	Fri 11/16/07	Mon 11/26/07																																																	
73	Enter Purchase requisition	1 hr	Fri 11/16/07	Fri 11/16/07																																																	
74	Approve Requisition	1 day	Fri 11/16/07	Mon 11/19/07																																																	
75	Purchase Order issued	5 days	Mon 11/19/07	Mon 11/26/07																																																	
76	Memotec	6.13 days	Fri 11/16/07	Mon 11/26/07																																																	
77	Enter Purchase requisition	1 hr	Fri 11/16/07	Fri 11/16/07																																																	
78	Approve Requisition	1 day	Fri 11/16/07	Mon 11/19/07																																																	
79	Purchase Order issued	5 days	Mon 11/19/07	Mon 11/26/07																																																	
80	Terrasat	6.13 days	Fri 11/16/07	Mon 11/26/07																																																	
81	Enter Purchase requisition	1 hr	Fri 11/16/07	Fri 11/16/07																																																	
82	Approve Requisition	1 day	Fri 11/16/07	Mon 11/19/07																																																	
83	Purchase Order issued	5 days	Mon 11/19/07	Mon 11/26/07																																																	
84	Integration Materials	4 wks	Mon 12/24/07	Fri 1/18/08																																																	
85	PROGRAM EXECUTION	189.38 days	Mon 10/29/07	Fri 7/18/08																																																	
86	Site Survey	40 days	Mon 10/29/07	Fri 12/21/07																																																	









Project: MEVA REDDIG INTERCONN
Date: Fri 10/19/07

Task Progress Summary External Tasks Deadline

Split Milestone Project Summary External Milestone







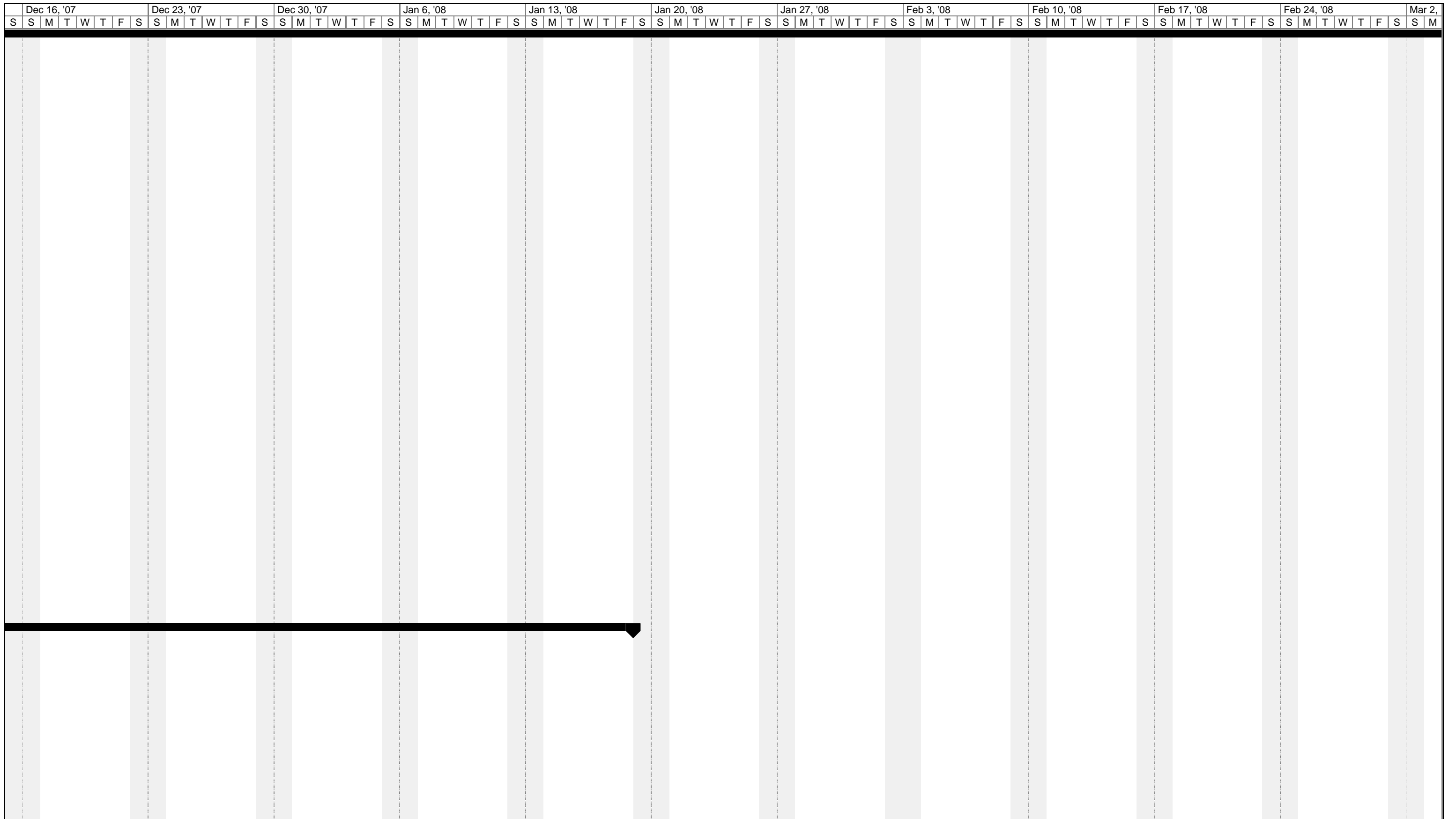

ID	Task Name	Duration	Start	Finish	Oct 28, '07							Nov 4, '07							Nov 11, '07							Nov 18, '07							Nov 25, '07							Dec 2, '07							Dec 9, '07													
					S	S	M	T	W	T	F	S	S	S	M	T	W	T	F	S	S	S	M	T	W	T	F	S	S	S	M	T	W	T	F	S	S	S	M	T	W	T	F	S	S	S	M	T	W	T	F	S	S	S	M	T	W	T	F	S
87	REDDIG Sites	40 days	Mon 10/29/07	Fri 12/21/07	[Summary bar]																																																							
88	Caracas, Venezuela	7 days	Mon 12/10/07	Tue 12/18/07	[Summary bar]																																																							
89	Perform Site Survey	2 days	Mon 12/10/07	Tue 12/11/07	[Task bar]																																																							
90	Issue Site Survey Report	0 days	Tue 12/18/07	Tue 12/18/07	[Task bar]																																																							
91	Bogota, Colombia	7 days	Thu 12/13/07	Fri 12/21/07	[Summary bar]																																																							
92	Perform Site Survey	2 days	Thu 12/13/07	Fri 12/14/07	[Task bar]																																																							
93	Issue Site Survey Report	0 days	Fri 12/21/07	Fri 12/21/07	[Task bar]																																																							
94	Manaos, Brazil	20 days	Mon 10/29/07	Fri 11/23/07	[Summary bar]																																																							
95	Site Complete Site Survey Form	1 mon	Mon 10/29/07	Fri 11/23/07	[Task bar]																																																							
96	Ecuador	20 days	Mon 10/29/07	Fri 11/23/07	[Summary bar]																																																							
97	Site Complete Site Survey Form	1 mon	Mon 10/29/07	Fri 11/23/07	[Task bar]																																																							
98	Lima, Peru	20 days	Mon 10/29/07	Fri 11/23/07	[Summary bar]																																																							
99	Site Complete Site Survey Form	1 mon	Mon 10/29/07	Fri 11/23/07	[Task bar]																																																							
100	System Manufacturing and Integration	8 days	Mon 3/31/08	Thu 4/10/08	[Summary bar]																																																							
101	Receive Major Equipment	0 days	Mon 3/31/08	Mon 3/31/08	[Summary bar]																																																							
102	ViaSat	0 days	Mon 3/31/08	Mon 3/31/08	[Summary bar]																																																							
103	Equipment Received	0 days	Mon 3/31/08	Mon 3/31/08	[Task bar]																																																							
104	Memotec	0 days	Mon 3/31/08	Mon 3/31/08	[Summary bar]																																																							
105	Equipment Received	0 days	Mon 3/31/08	Mon 3/31/08	[Task bar]																																																							
106	Terrasat	0 days	Mon 3/31/08	Mon 3/31/08	[Summary bar]																																																							
107	Equipment Received	0 days	Mon 3/31/08	Mon 3/31/08	[Task bar]																																																							
108	Equipment Integration	5 days	Mon 3/31/08	Mon 4/7/08	[Summary bar]																																																							
109	First Unit	5 days	Mon 3/31/08	Mon 4/7/08	[Summary bar]																																																							
110	Rack Equipment	1 day	Mon 3/31/08	Tue 4/1/08	[Task bar]																																																							
111	Manufacture / Run Wiring	1 wk	Mon 3/31/08	Mon 4/7/08	[Task bar]																																																							
112	Remaining Units	5 days	Mon 3/31/08	Mon 4/7/08	[Summary bar]																																																							
113	Rack Equipment	1 day	Mon 3/31/08	Tue 4/1/08	[Task bar]																																																							
114	Manufacture / Run Wiring	1 wk	Mon 3/31/08	Mon 4/7/08	[Task bar]																																																							
115	Equipment Configuration	7 days	Tue 4/1/08	Thu 4/10/08	[Summary bar]																																																							
116	Configure First Unit	1 day	Tue 4/1/08	Wed 4/2/08	[Task bar]																																																							
117	Write Configuration Procedure	1 day	Wed 4/2/08	Thu 4/3/08	[Task bar]																																																							
118	Configure Remaining Units	1 wk	Thu 4/3/08	Thu 4/10/08	[Task bar]																																																							
119	System Testing	6 days	Thu 4/10/08	Fri 4/18/08	[Summary bar]																																																							
120	Transport to Test Facility	1 day	Thu 4/10/08	Fri 4/11/08	[Task bar]																																																							
121	Factory Acceptance Testing	1 wk	Fri 4/11/08	Fri 4/18/08	[Task bar]																																																							
122	FAT Testing Complete	0 days	Fri 4/18/08	Fri 4/18/08	[Task bar]																																																							
123	Shipping	15 days	Fri 4/18/08	Fri 5/9/08	[Summary bar]																																																							
124	Prepare Units for Shipping	1 wk	Fri 4/18/08	Fri 4/25/08	[Task bar]																																																							
125	Prepare Shipping Documentation	1 wk	Fri 4/18/08	Fri 4/25/08	[Task bar]																																																							
126	Ship Units to Sites	1 wk	Fri 4/25/08	Fri 5/2/08	[Task bar]																																																							
127	REDDIG Sites	5 days	Fri 5/2/08	Fri 5/9/08	[Summary bar]																																																							
128	Caracas, Venezuela	5 days	Fri 5/2/08	Fri 5/9/08	[Summary bar]																																																							
129	Cleared Customs	1 wk	Fri 5/2/08	Fri 5/9/08	[Task bar]																																																							
130	Equipment On Site	0 days	Fri 5/9/08	Fri 5/9/08	[Task bar]																																																							

Project: MEVA REDDIG INTERCONN
Date: Fri 10/19/07

Task  Progress  Summary  External Tasks  Deadline 
 Split  Milestone  Project Summary  External Milestone 







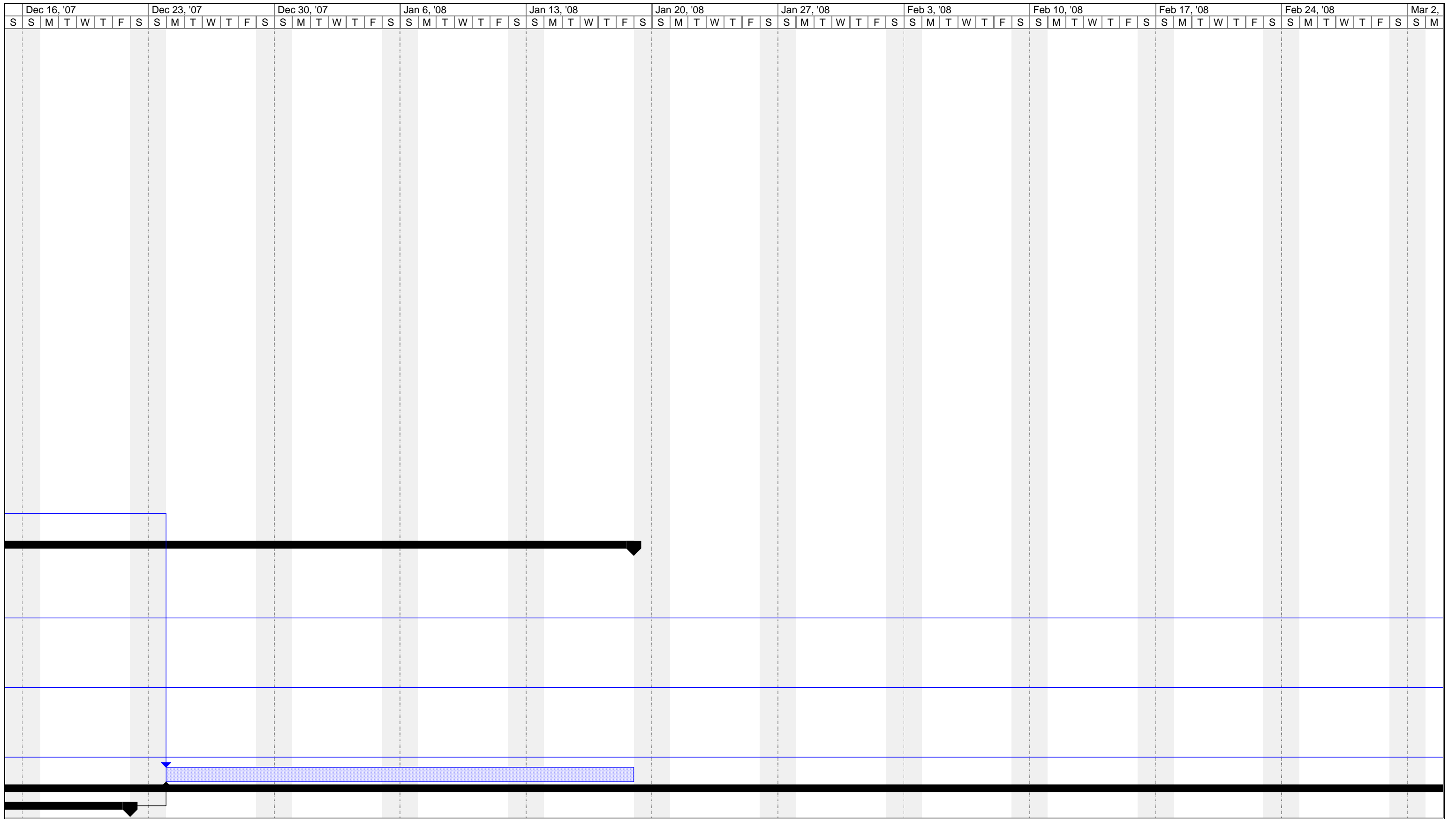



Project: MEVA REDDIG INTERCONN
Date: Fri 10/19/07

Task		Progress		Summary		External Tasks		Deadline	
Split		Milestone		Project Summary		External Milestone			











Project: MEVA REDDIG INTERCONN
Date: Fri 10/19/07

Task		Progress		Summary		External Tasks		Deadline	
Split		Milestone		Project Summary		External Milestone			



Project: MEVA REDDIG INTERCONN
Date: Fri 10/19/07

Task		Progress		Summary		External Tasks		Deadline	
Split		Milestone		Project Summary		External Milestone			







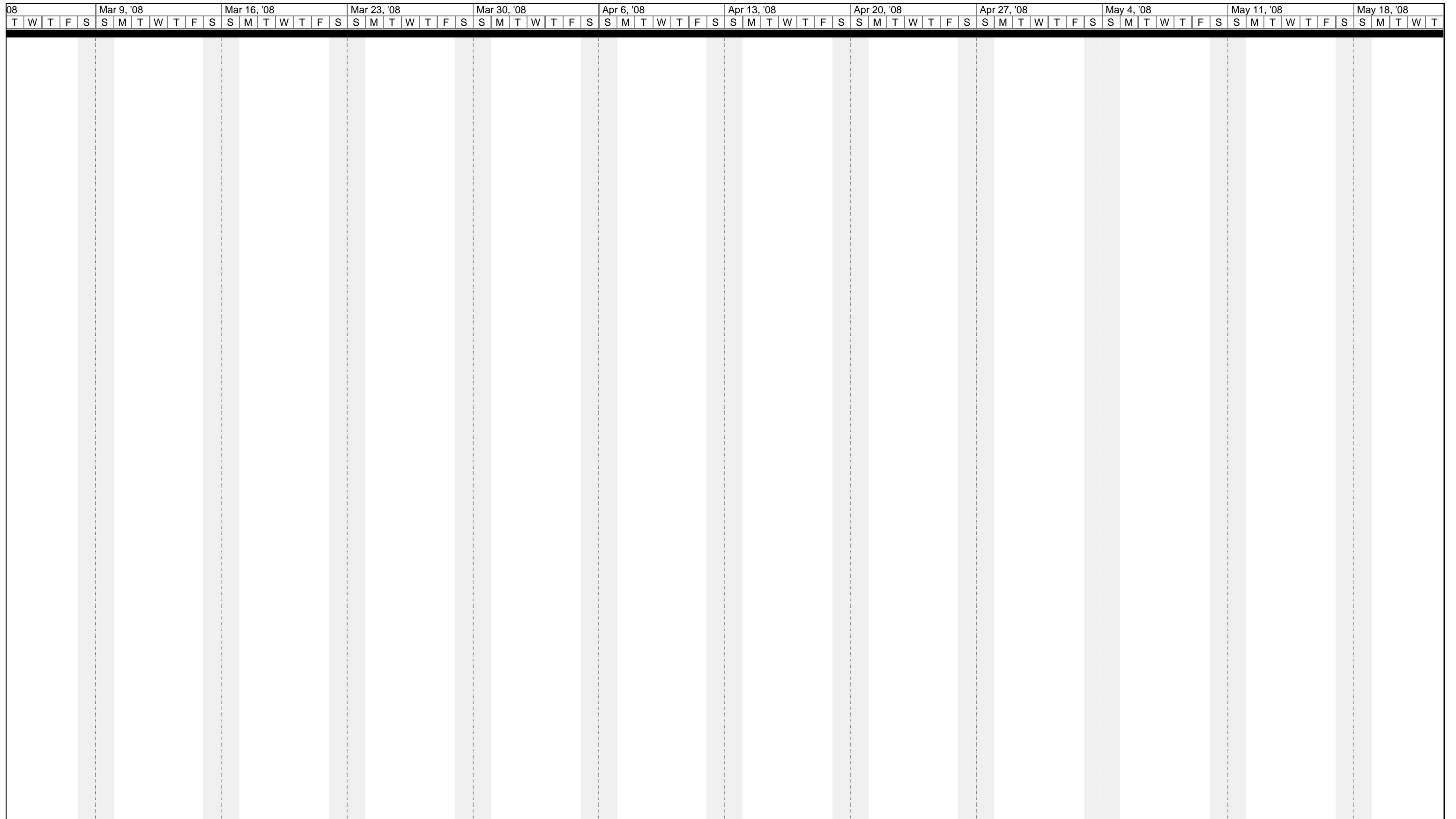

Dec 16, '07							Dec 23, '07							Dec 30, '07							Jan 6, '08							Jan 13, '08							Jan 20, '08							Jan 27, '08							Feb 3, '08							Feb 10, '08							Feb 17, '08							Feb 24, '08							Mar 2, '08														
S	S	M	T	W	T	F	S	S	M	T	W	T	F	S	S	M	T	W	T	F	S	S	M	T	W	T	F	S	S	M	T	W	T	F	S	S	M	T	W	T	F	S	S	M	T	W	T	F	S	S	M	T	W	T	F	S	S	M	T	W	T	F	S	S	M	T	W	T	F	S	S	M	T	W	T	F	S	S	M	T	W	T	F	S	S	M	T	W	T	F	S



Project: MEVA REDDIG INTERCONN Date: Fri 10/19/07	Task		Progress		Summary		External Tasks		Deadline	
	Split		Milestone		Project Summary		External Milestone			



Project: MEVA REDDIG INTERCONN
 Date: Fri 10/19/07

Task		Progress		Summary		External Tasks		Deadline	
Split		Milestone		Project Summary		External Milestone			

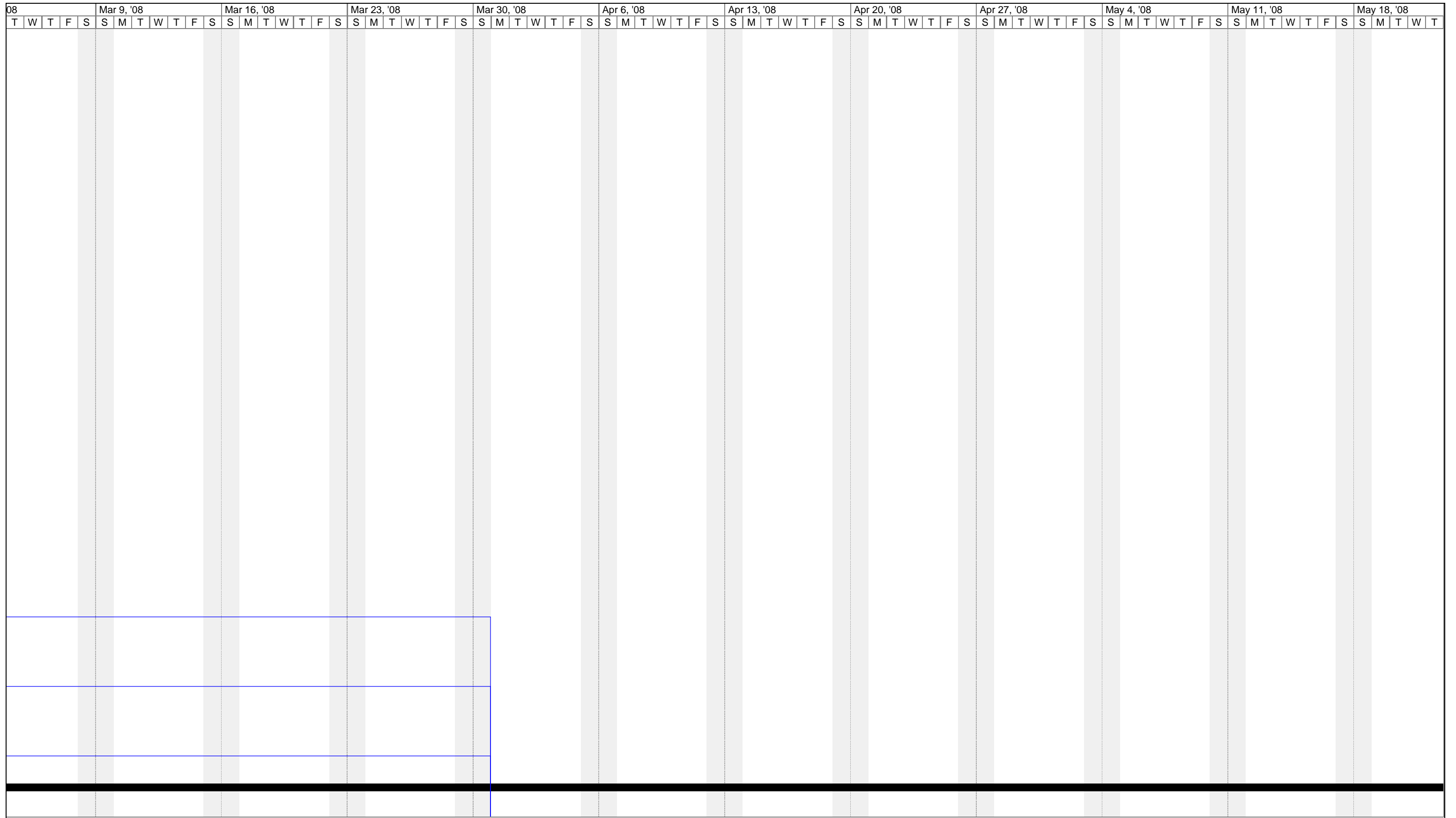

Project: MEVA REDDIG INTERCONN
 Date: Fri 10/19/07

Task		Progress		Summary		External Tasks		Deadline	
Split		Milestone		Project Summary		External Milestone			

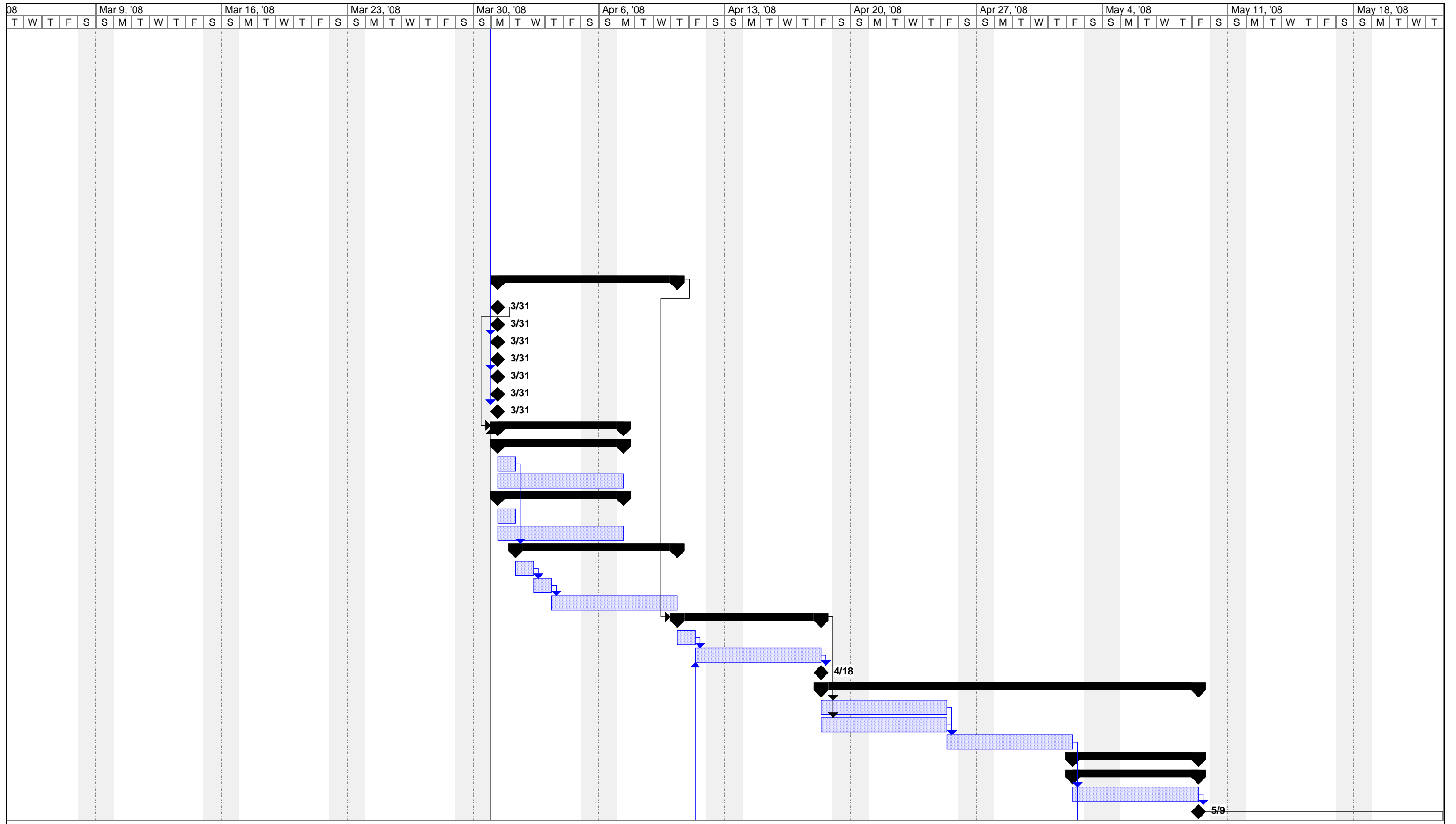

Project: MEVA REDDIG INTERCONN
Date: Fri 10/19/07

Task		Progress		Summary		External Tasks		Deadline	
Split		Milestone		Project Summary		External Milestone			

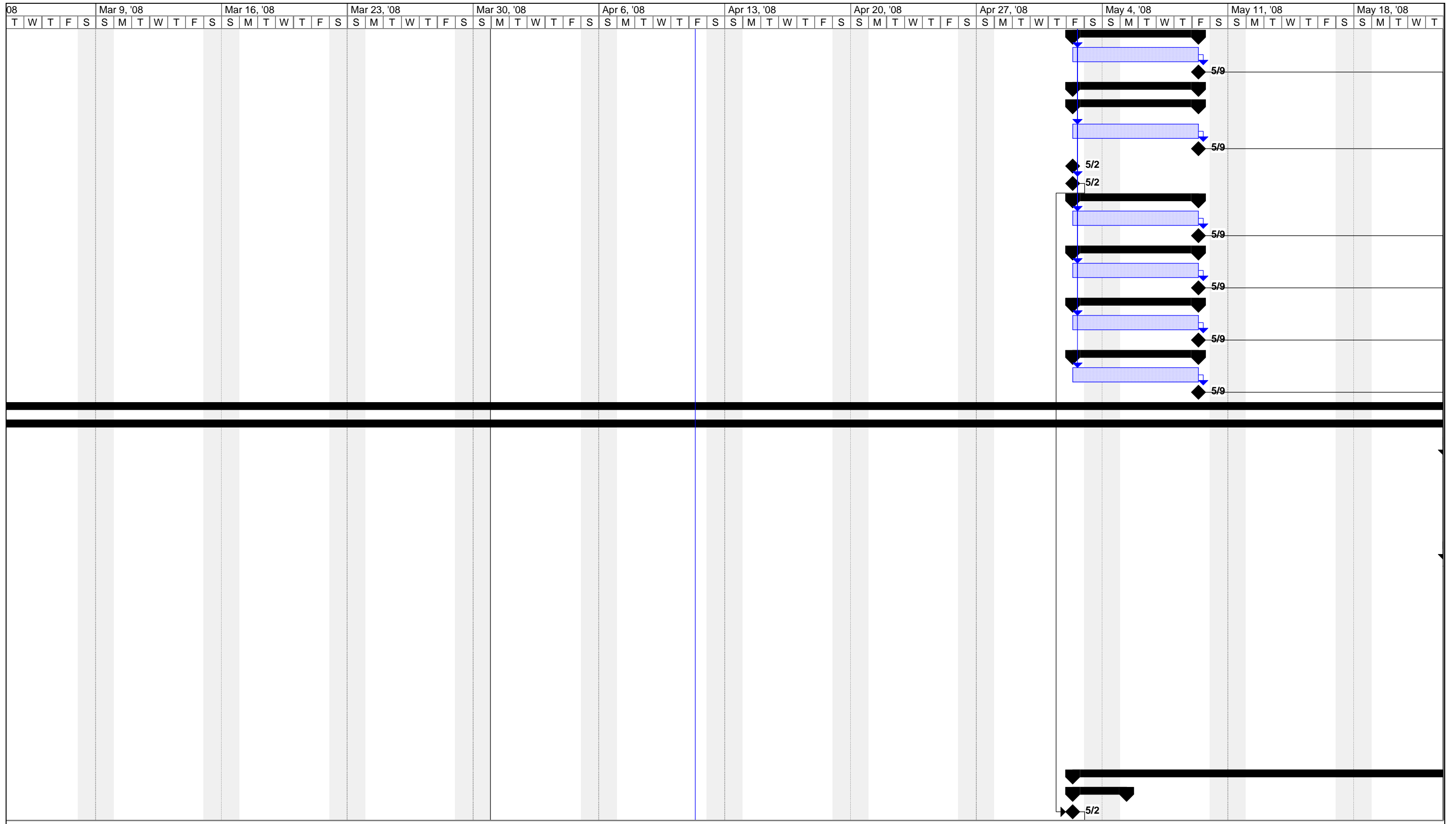





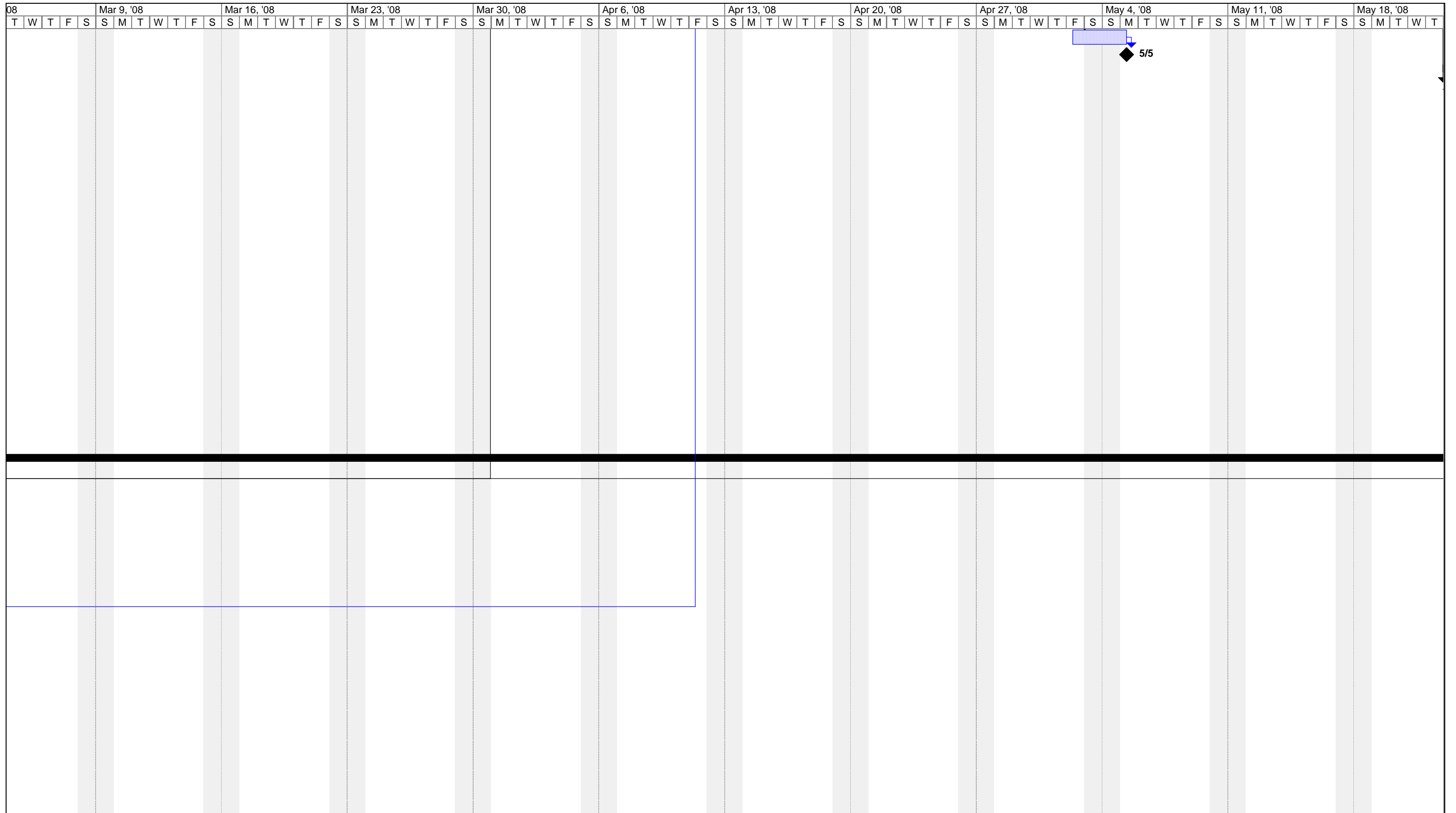



Project: MEVA REDDIG INTERCONN
Date: Fri 10/19/07

Task		Progress		Summary		External Tasks		Deadline	
Split		Milestone		Project Summary		External Milestone			



Project: MEVA REDDIG INTERCONN
Date: Fri 10/19/07



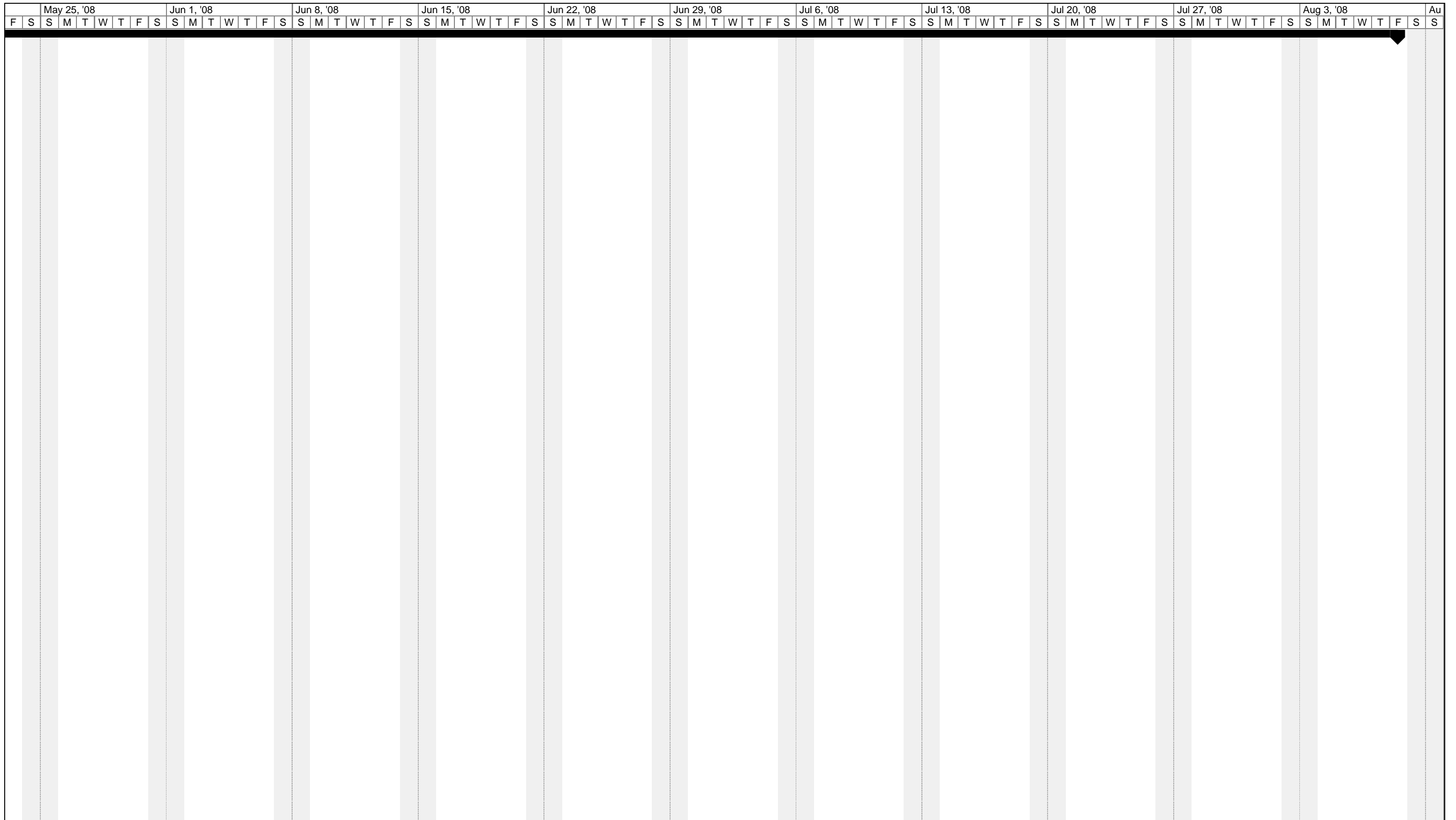



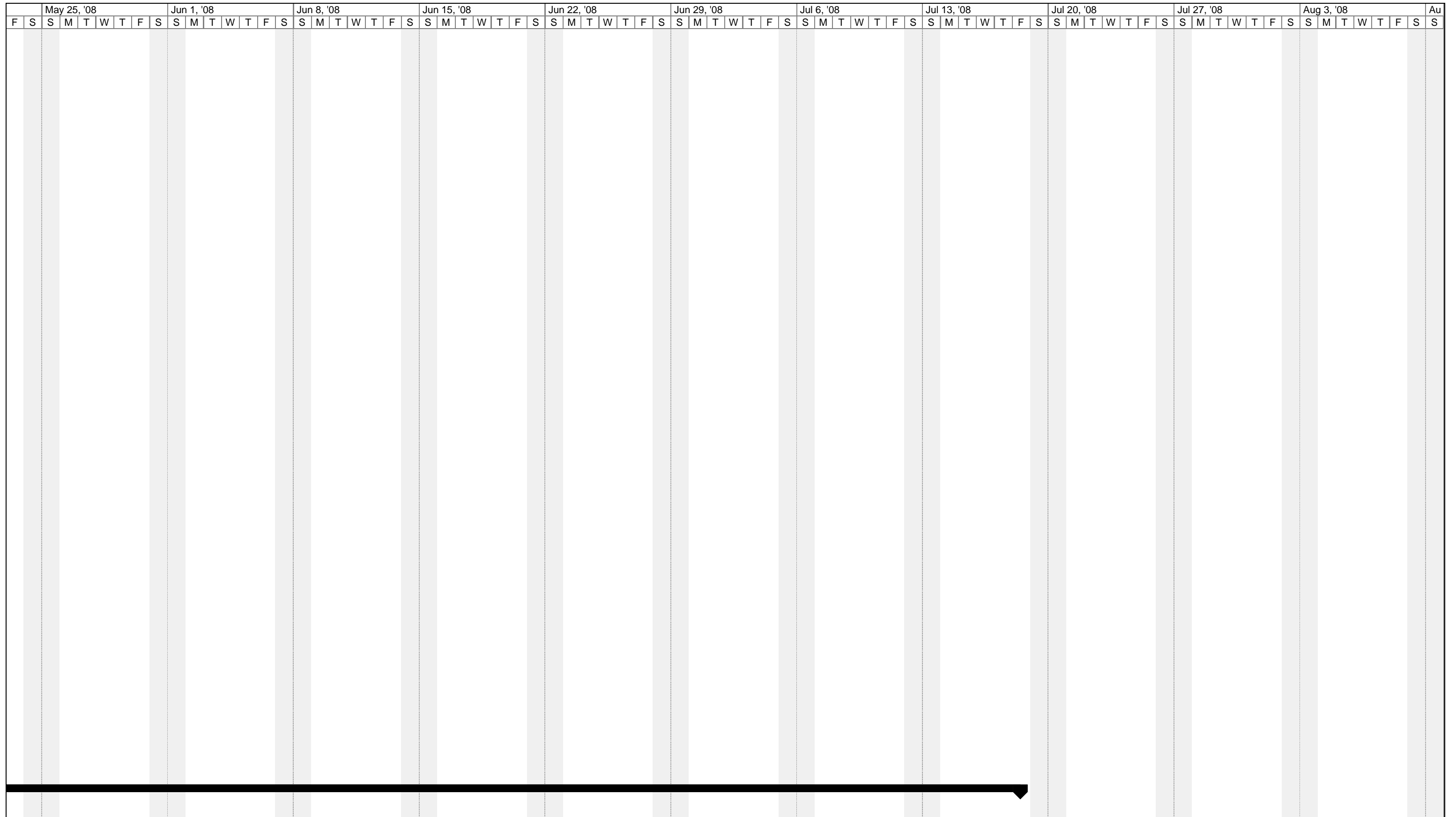

Task		Progress		Summary		External Tasks		Deadline	
Split		Milestone		Project Summary		External Milestone			











Project: MEVA REDDIG INTERCONN Date: Fri 10/19/07	Task		Progress		Summary		External Tasks		Deadline	
	Split		Milestone		Project Summary		External Milestone			



Project: MEVA REDDIG INTERCONN
 Date: Fri 10/19/07

Task		Progress		Summary		External Tasks		Deadline	
Split		Milestone		Project Summary		External Milestone			

		May 25, '08							Jun 1, '08							Jun 8, '08							Jun 15, '08							Jun 22, '08							Jun 29, '08							Jul 6, '08							Jul 13, '08							Jul 20, '08							Jul 27, '08							Aug 3, '08							Au
F	S	S	M	T	W	T	F	S	S	M	T	W	T	F	S	S	M	T	W	T	F	S	S	M	T	W	T	F	S	S	M	T	W	T	F	S	S	M	T	W	T	F	S	S	M	T	W	T	F	S	S	M	T	W	T	F	S	S																					

Project: MEVA REDDIG INTERCONN Date: Fri 10/19/07	Task		Progress		Summary		External Tasks		Deadline	
	Split		Milestone		Project Summary		External Milestone			

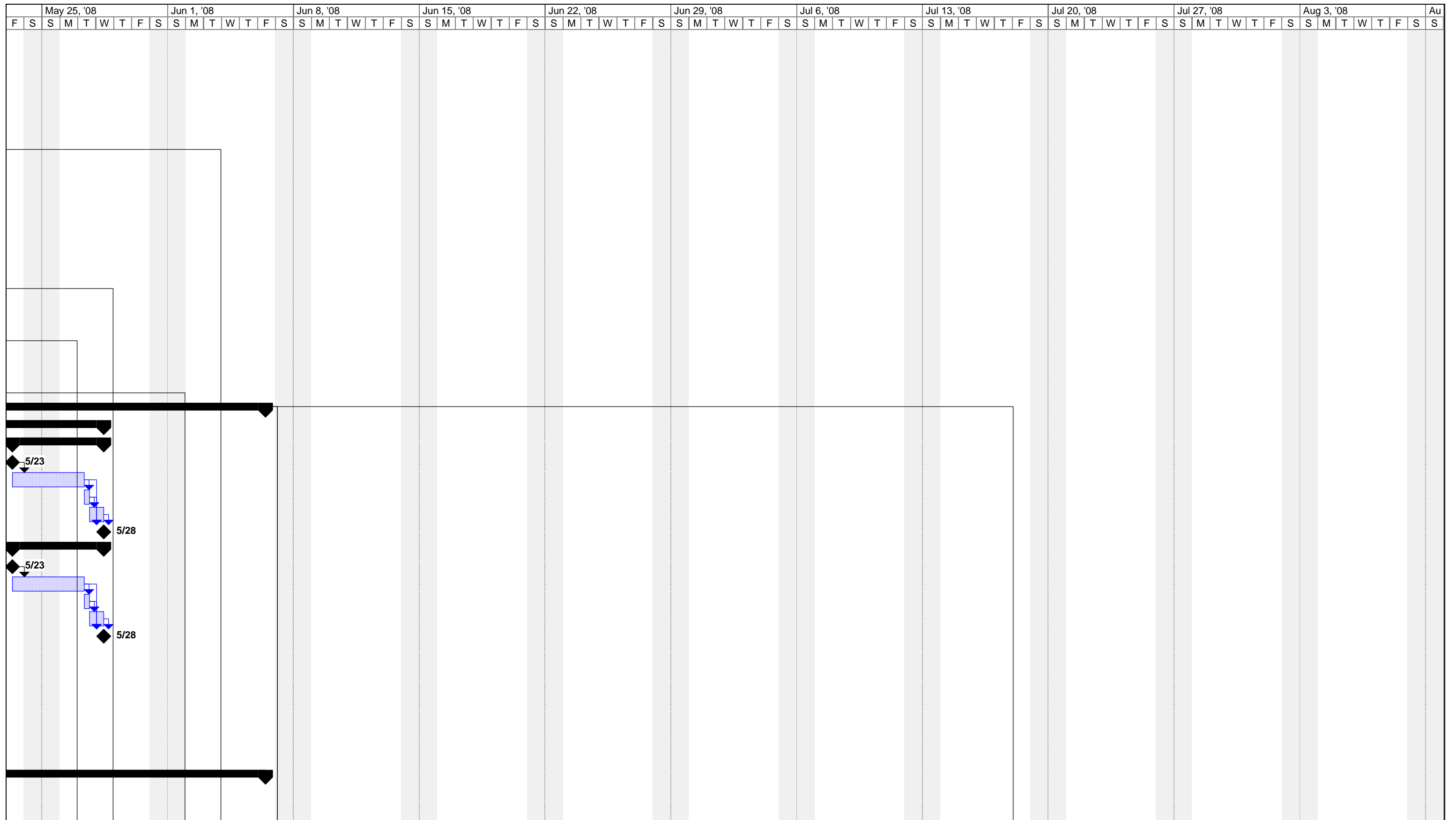

Project: MEVA REDDIG INTERCONN
Date: Fri 10/19/07

- Task Progress Summary External Tasks Deadline
- Split Milestone Project Summary External Milestone

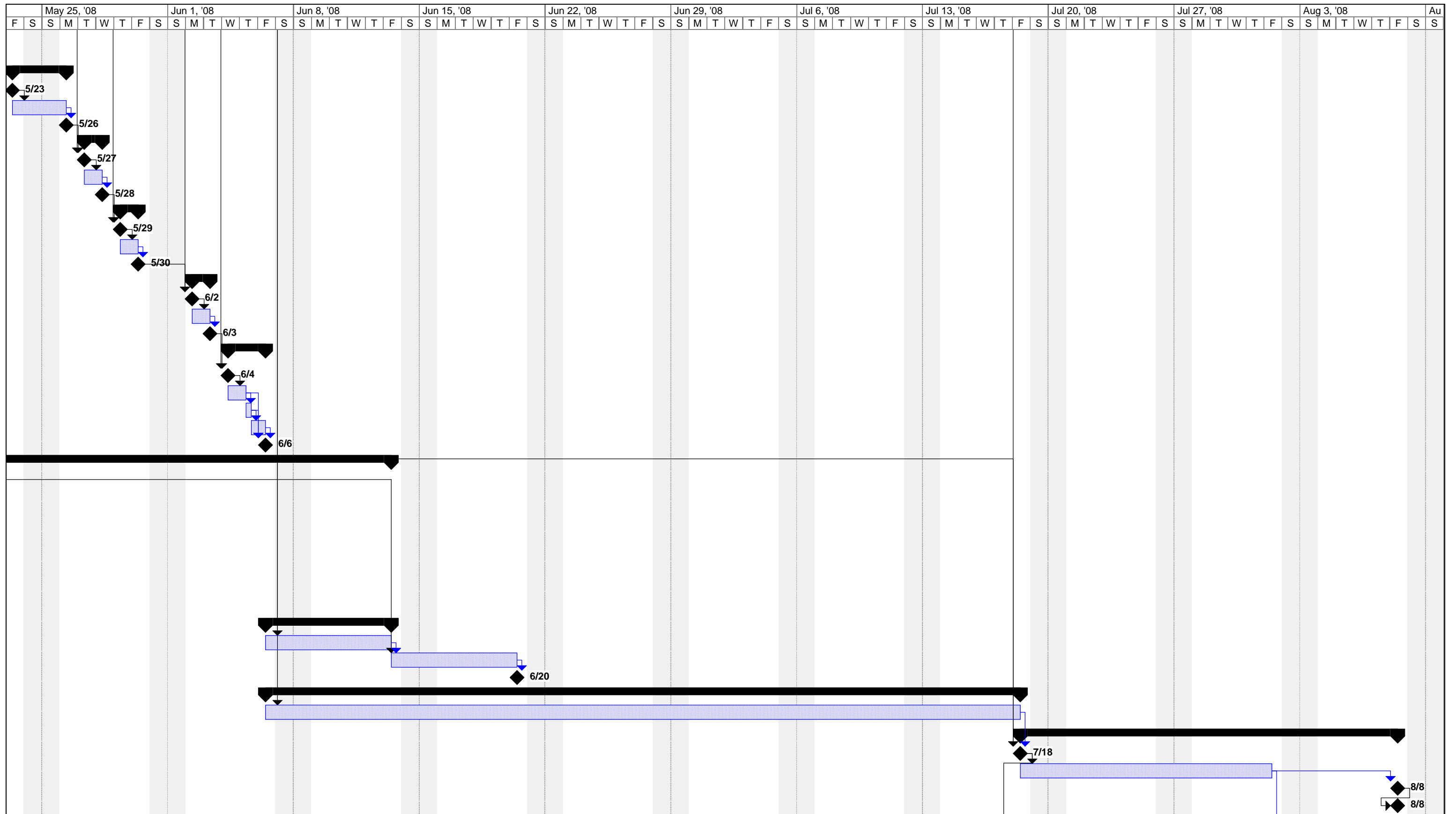

Project: MEVA REDDIG INTERCONN
 Date: Fri 10/19/07

Task		Progress		Summary		External Tasks		Deadline	
Split		Milestone		Project Summary		External Milestone			

Attachment D: Technical Documentation

- 1. Terrasat BUC**
- 2. Terrasat 1:1 Redundant Switch**

CONFIDENTIAL

Use, duplication and disclosure of the information contained on this page is subject to the restrictions contained in the CONFIDENTIAL NOTICE on the title (first) page of this proposal.

IBUC Advantages

NEW! 50W IBUC model available.

NEW! Low profile fan shroud on 20W and above.

NEW! 20W and 25W DC power can be supplied via IFL coax or separate DC connector.

Integrated BUC/SSPA packaging for higher performance and reliability.

Guaranteed rated output power across the entire operating temperature range and frequency band.

Low phase noise exceeds IESS308/309 requirements by a minimum of 10dB.

Embedded web pages provide management for small networks using any web browser.

AGC or ALC circuits hold gain or output level constant.

16dB User-adjustable gain in 0.1 dB steps preserves modem dynamic range.

Advanced customer interfaces:

- TCP/IP HTTP with embedded web pages.
- **NEW!** SNMP.
- TELNET through TCP/IP
- FSK through TX IFL cable.
- RS232/485 serial port.
- Handheld terminal.

1+1 switching logic built into IBUC eliminates expensive external controller.



The revolutionary **IBUC** has advanced features to take your network to new heights.

Compared to traditional 70 MHz solutions, the **IBUC** offers significant benefits:

- Lower terminal cost
- Simpler design and installation
- Superior RF performance
- Simplified 1+1 configuration

New interfaces connect you to the **IBUC**'s extensive M&C facilities for network management or local access. This powerful new M&C enables:

- **Trouble free commissioning** with easy, point-and-click installation/configuration
- Continuous **verification** of performance with alarm history.
- Simplified **troubleshooting** of terminal faults.

The **IBUC** comes with a complete set of diagnostic tools including:

- 10 MHz input detector
- Input voltage and current monitoring
- Transmit L-band input level detector
- Transmit RF output level detector
- Alarm history

As always, the **IBUC** carries Terrasat's guarantee of rated output power across the operating band and specified temperature range. Unique in the **IBUC** are internal AGC and ALC functions to satisfy demanding applications with stringent specifications.

The **IBUC** is manufactured in our modern Morgan Hill, CA facility to the same exacting quality processes as our PowerPlus series and OEM microwave products. Each unit undergoes rigorous testing, burn-in at elevated temperature, BER, and final testing over temperature so that you are assured of a high quality, reliable product.

For additional information contact Terrasat Sales at +1 408-782-5911 or by Email: Sales@Terrasatinc.com.

C-Band IBUC Block Upconverter Specifications

L-Band Input		External Reference (multiplexed on TX IFL)	
Frequency range		Frequency	10 MHz
Band 1	950 to 1525 MHz	Level	-12 to +3 dBm
Bands 2 & 3	1150 to 1450 MHz		
Band 4	950 to 1750 MHz	Local Oscillator	
VSWR / Impedance	1.5:1 max / 50 ohms	LO Frequency	
Connector	Type N female	Band 1	7375 MHz
Input power detector range	-55 to -20 dBm	Band 2	7875 MHz
		Band 3	8175 MHz
		Band 4	7600 MHz
Gain		Sense	Inverting
Small Signal Gain (L-band to RF) with attenuator set to 0 dB		IBUC DC Supply	
5W	68 dB min	Multiplexed on TX IFL	5W, 10W, 20W, 25W
10W	71 dB min	Connector	MS3102R14S-6P
20W	74 dB min	Voltage / Current	
25W	75 dB min		+24 ± 4 VDC +48 ± 11 VDC
40W	77 dB min	5W	3.0A @ 24VDC 1.5A @ 48VDC 72W
50W	78 dB min	10W	4.0A @ 24VDC 2.0A @ 48VDC 96W
60W	79 dB min	20W	na 3.2A @ 48VDC 154W
80W	80 dB min	25W	na 3.5A @ 48VDC 168W
Attenuator range	16 dB variable in 0.1dB steps	40W	na 7.5A @ 48VDC 360W
Gain flatness	<u>5 W to 50 W</u> <u>60W to 80W & Band 4</u>	50W	na 8.5A @ 48VDC 408W
Full band	3 dB p-p max 4dB p-p max	60W	na 9.0A @ 48VDC 432W
36 MHz	1dB p-p max 1 dB p-p max	80W	na 11.5A @ 48VDC 552W
1 MHz	0.25 dB p-p 0.25 dB p-p		
Gain variation over temperature		Monitor and Control	
Open loop	3 dB p-p max 4 dB p-p max	FSK (multiplexed on TX IFL)	
With AGC	1 dB p-p max 1 dB p-p max	Transmitter	
		Frequency	650 kHz ± 5%
RF Output	Frequency range	Deviation	± 60 kHz
Band 1 Standard C-Band	5850 to 6425 MHz	Output Level	-5 to -15 dBm (50 ohms)
Band 2 Palapa/ST-1	6425 to 6725 MHz	Receiver	
Band 3 Insat	6725 to 7025 MHz	Nominal frequency	650 kHz
Band 4 Extended C-Band	5850 to 6650 MHz	Locking range	± 32.5 kHz
Interface	CPR-137G or N-f	Input sensitivity	-15 dBm
VSWR	1.5:1 max	Interfaces (RS232, RS485, TCP/IP and Handheld Terminal)	
Rated output power (P1dB across temperature range and freq. band)		Connector	MS3112E-14-19S
5W	+37 dBm min	RS232/485	
10W	+40 dBm min	Data Rate	Selectable 1.2 to 115.2 kbps
20W	+43 dBm min	Data Format	8 bits, no parity, 1 stop bit, ASCII
25W	+44 dBm min Ext C +43.5dBm	Handheld Terminal data rate	9600 bps
40W	+46 dBm min	TCP / IP	Telnet, HTTP, SNMP
50W	+47 dBm min	Environmental	<u>5 W to 40 W</u> <u>50W to 80W</u>
60W	+47.8 dBm min	Operating temperature	-40°C to +60°C -40°C to +55°C
80W	+49 dBm min	Relative humidity	100% condensing
IMD3 (2 carriers, 30 kHz apart, 9dB BO/carrier)	-32 dBc max	Altitude	10,000 ft., (3,000m) ASL
Level stability with ALC	± 0.5 dB	Mechanical	
Output power detector range	Rated power to -20 dB		
Power reading accuracy	+/- 1.0 dB max.		
Spurious	Complies with EN 301 443		
SSB Phase Noise	External reference IBUC		
10Hz	-120 dBc/Hz -35 dBc/Hz		
100Hz	-130 dBc/Hz -70 dBc/Hz		
1 kHz	-143 dBc/Hz -80 dBc/Hz		
10 kHz	-152 dBc/Hz -90 dBc/Hz		
100kHz	-155 dBc/Hz -100 dBc/Hz		
1MHz	-155 dBc/Hz -110 dBc/Hz		

Specifications are subject to change without notice



235 Vineyard Court
Morgan Hill, CA 95037
Tel. +1 408.782.5911
Fax: +1 408.782.5912
www.terrasatinc.com

C-Band IBUC Data Sheet 11/30/06

Advantages

1+1 switching logic and drivers reside in the IBUCs - no external logic controller required.

Web browser interface with embedded web pages for easy setup, monitor, and control.

Auto-Cloning function means user sets up primary IBUC as desired and secondary unit clones its settings.

LEDs provide quick visual indication of IBUC condition.

Compact, integrated mounting package.

Access via:

- FSK through TX IFL cable.
- TCP/IP with embedded web pages.
- SNMP agent
- RS485/232 serial port.
- Handheld Terminal.

Separate outdoor RX 1+1 controller powered by IBUC power supplies is available.

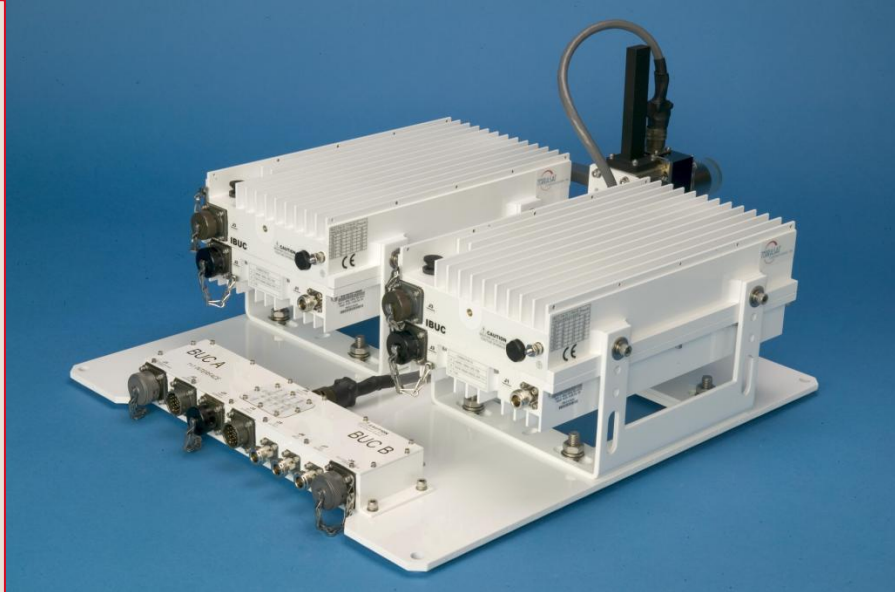

The integration of 1+1 protection was a key design goal in Terrasat's IBUC Intelligent Block Upconverters development. The IBUC redefines 1+1 protection switching. Instead of using a separate switching logic unit with its expense and complexity, Terrasat incorporated the switching logic and drivers into the IBUC itself.

Protected units monitor each other's alarm condition and, through a simple switching junction box, make the decision to switch. The IBUC 1+1 package includes a cloning feature to simplify 1+1 setup. Terrasat's 1+1 solution is a complete package with a dual-IBUC mounting bracket for convenient installation.

A 1+1 junction box mounts on the 1+1 mounting plate. Practically a passive unit, the junction box manages the functions of dividing the IF signal and routing signals through an Ethernet switch. It supports interface connectors and includes a bank of LEDs for visual indication of alarm conditions. The user interface is via web browser to embedded web pages, handheld terminal, RS232 or RS485.

A Receive 1+1 system is available with a separate outdoor RX interface box. The receive interface box receives DC power from the IBUC power supplies and performs all required functions for 1+1 operation of LNB's. No indoor controller is necessary. Monitoring and control is via TCP/IP port on the interface box. The interface box fits the Terrasat universal mounting bracket and the system comes with cables and waveguide switch.

IBUC 1+1 System Block Diagram

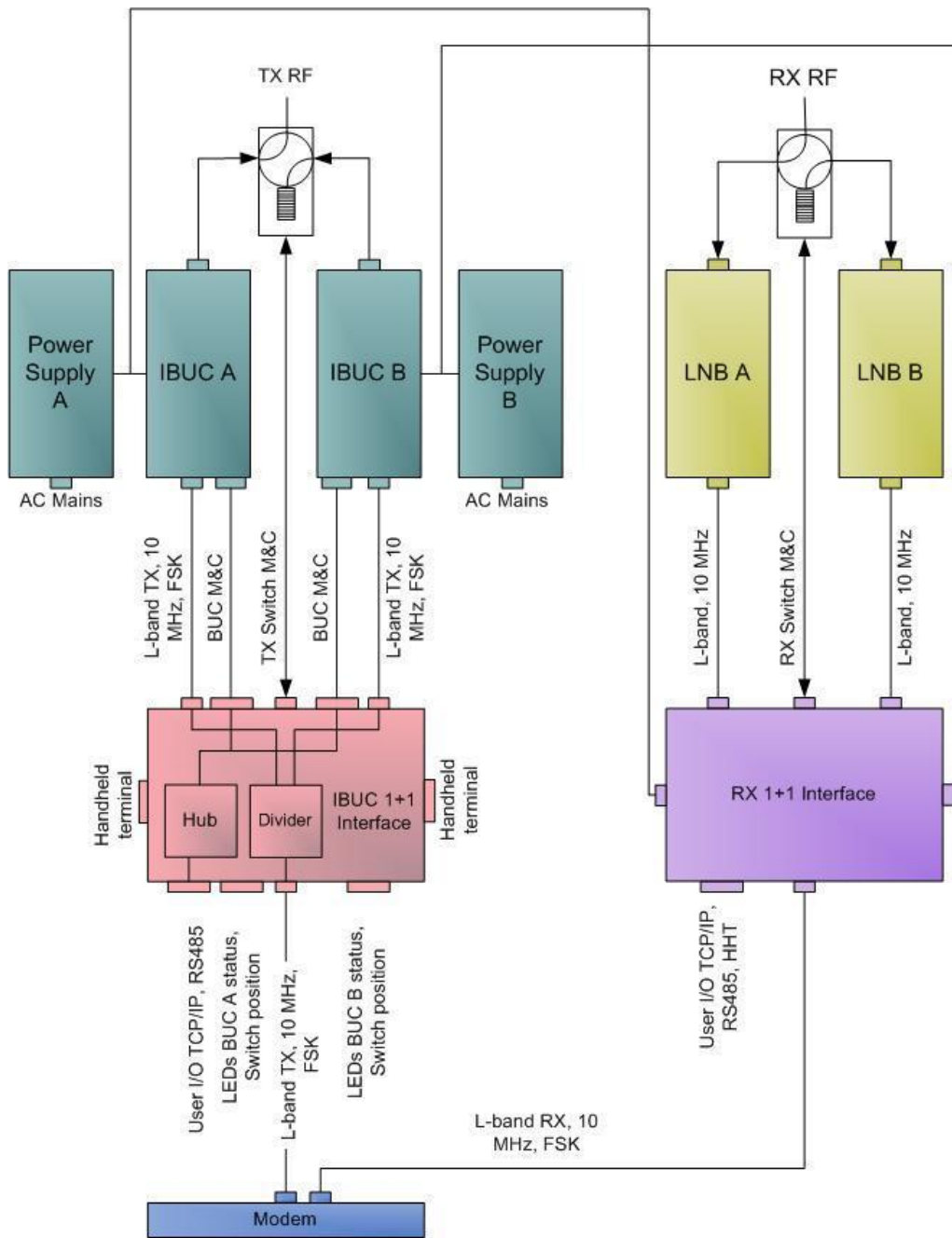

1+1 TX/RX



235 Vineyard Court
 Morgan Hill, CA 95037
 Tel. +1 408.782.5911
 Fax: +1 408.782.5912
 www.terrasatinc.com

Specifications are subject to change without notice

Attachment E: SES AMERICOM Woodbine, MD Teleport

CONFIDENTIAL

Use, duplication and disclosure of the information contained on this page is subject to the restrictions contained in the CONFIDENTIAL NOTICE on the title (first) page of this proposal.

SES AMERICOM Woodbine, MD Teleport



Figure 1: AMERICOM's Woodbine, MD Teleport and NMC

AMERICOM's Woodbine, MD Teleport

- Domestic and International turnarounds, from 6 West to 146 West
- Fiber connectivity to Baltimore, MD and Level-3 in McLean, VA
- Established in 1982

Location, Latitude and Longitude

Woodbine is located approximately one hour from both downtown Washington, DC and Baltimore, MD, and is easily accessible from the Baltimore/Washington International Thurgood Marshall Airport. This teleport is located at 39.4 North latitude and 77.1 West longitude, and 182 meters AMSL in elevation.

Services

Woodbine provides Internet, voice, data and digital/ analog video services for almost any application.

CONFIDENTIAL

Use, duplication and disclosure of the information contained on this page is subject to the restrictions contained in the CONFIDENTIAL NOTICE on the title (first) page of this proposal.

Customers and Regions Served

Serves the transmission needs of ISPs, television broadcasters, cable programmers, government agencies, carriers, business television, and radio users. Services the Americas and Europe via the large and growing SES spacecraft fleet.

Years in Operation

Woodbine provides Internet, voice, data and digital/ analog video services for almost any application.

Precipitation

Woodbine, Maryland averages approximately 40 inches of precipitation annually.

Connectivity

- Direct access to majority of the SES satellite fleet (Simulsat access to third-party birds)
- Fiber interconnections with Tier-1 ISPs
- Direct access to 60 Hudson Street in New York City and Level-3 in Tysons Corner, VA
- Convenient access to MAE-East in New York and Washington, DC
- OC-12 SONET fiber with 2 diverse paths into Woodbine compound

Facility

Woodbine is a 15,000 square foot facility situated on 27 acres of land. The teleport features major C-, Ku-, and Ka-band antennas on most SES birds and a Simulsat antenna for additional third-party contribution feeds. Also, techs are available 24x7 for operations, payload management, and spacecraft operations process support.

Electrical Backup System

Woodbine emergency power system includes tri-redundant 625 kW generators and three 270 kW UPSs.

Manpower and Staffing

Woodbine is staffed with experienced earth station operations, logistics, IT, IP transport engineering, and spacecraft operations teams. The Operations staff includes technicians that are available 24x7, 365 days a year. In addition, circuit implementation and support teams are available.

Facility is most noted for

Platforms: including Linkway, Surfbeam, DAMA, iDirect, Digital-C, Digital-K, Ethnic, IPTV, and DVB. Also, has access to the majority of the satellite SES fleet - including AMC-12. Lastly, noted as being the home of the Payload Management and TT&C Spacecraft Operations centers.

CONFIDENTIAL

Attachment F: MEVA II – Advanced Technician Training Guide

CONFIDENTIAL

Use, duplication and disclosure of the information contained on this page is subject to the restrictions contained in the CONFIDENTIAL NOTICE on the title (first) page of this proposal.



ICAO

MEVA II
Advanced Training
September 2007

Table of Contents

MEVA II Advanced Training	5
MEVA II Introduction	7
Overview	7
Types of MEVA II Communications	8
Data	8
Voice	8
MEVA II Network Diagram	9
MEVA II System Components	10
Outdoor Equipment	10
VSAT	11
Parabolic Reflector	11
Co-Pol Feed	11
Azimuth and Elevation Adjustment bolts	11
Feed Support Arm	11
Mounting Post	11
LNB	12
BUC	13
IBUC Components	14
DC Supply	14
Monitor and Control	15
RF Signal Flow	15
AST 5100	16
Indoor Equipment	17
Memotec CX960e	18
CPU Module Components	19
Front Panel	19
Inserting/Removing the CPU or Power Supply Modules	21
Motherboard	22
Processing Section	23
RAM Installation	23
I/O Section	24
Power Section	24
I/O Cards Module Components	24
V.24 Serial I/O Card	25
V.35 H Serial I/O Card	28
DAV Serial I/O Card	31
SLIM LIDs (FXS, E&M)	33
Configuring Voice SLIM LIDs	34
SEM Card Installation	36
I/O Card Installation	37
Front-Loading I/O Cards	37

Top-Loading I/O Cards	39
Power Supply Module Components	40
Linkway 2100	40
The Linkway Network	41
Basic Components of a Linkway Network.....	42
Linkway Modem.....	43
The Linkway NCC.....	44
AST 3100	45
Liebert UPS.....	45
CISCO Ethernet Switch.....	45
Network Operation	46
How Communication is Established Over the Linkway	46
MEVA II Network Synchronization Diagram	47
Traffic Bursts Diagram	48
Burst Types.....	49
Packet Bursts	50
Linkway TDMA Architecture	51
Frame Format and Hierarchy	51
TDMA Frame Structure.....	52
TDMA Burst Structure.....	53
Single-Beam and Multiple-Beam Operation.....	54
Site and Terminal Addressing	55
Acquisition and Synchronization.....	55
Clock Management.....	55
Packet and Transport Services	56
Linkway Protocols and Services.....	57
IP Service	57
RIP (Routing Information Protocol)	58
IP Service Provisioning	59
IP Service Operations.....	59
Frame Relay Service	60
Frame Relay Service Provisioning.....	61
Frame Relay Service Operation.....	61
Troubleshooting Concepts	62
Initially Reporting a Problem	62
Documenting a Problem.....	62
Fault Isolation	63
Problem Resolution	64
Common Problems List	64
Preventive and Corrective Maintenance	67
Reporting an Outage	67
Scheduling Downtime for Maintenance	68
Example of the MOP Form.....	69
RMA and Shipping	71

RMA Number Assignment.....	71
Network Management	72
Configuration Management.....	72
Acquisition and Synchronization Control.....	72
Bandwidth Management	73
Fault Protection	74
Accounting	75
Performance and Alarm Management	75
Security Management	77
Procedures	78
General	78
Test Equipment Setup and Use	78
Setting the TX and RX Frequencies	79
Receive L-band Output Measurements	79
Antenna Peak and POL (Polarization)	79
Initial Alignment	80
TX Power Alignment.....	81
Transmit L-band Input Adjustment with Modem/Converter.....	81
Transmit RF Output Adjustment with Modem or Converter.....	81
Site Selection	82
Sealing Connectors.....	82
Loading Boot Files in the Linkway 2100.....	82
Preventive Maintenance.....	83
ODUs	83
IBUC/PSUI Grounding Recommendations.....	83
Periodic Inspection of the Prodelin Antenna.....	84
Reflector	84
Mount and Reflector Support Structure	84
Feed and Feed Support.....	84
Monthly Maintenance	85
Every Six Months	85
Annual Maintenance	85
Corrective Maintenance	85
Fault Isolation of ODU's	86
Standard Maintenance	86
Transceiver Fault Isolation	86
AC Power Problems/Conditioning	86
Site-Related Problems.....	86
M&C Checks	86
Power Supply Checks	87
Transmit Power Setting	87
TX IF Input Level Verification	87
IBUC TX Output Verification.....	88
Receive L-band Output Verification	88

Repair Policy88
Component Replacement.....89
Recovery Testing89
Interference Testing89
MEVA II Acronyms, Abbreviations and Terms90
Applicable Documents 106

MEVA II Advanced Training

Purpose: The purpose of this document and training is to provide MEVA II site technicians with the skills necessary to maintain, troubleshoot, and restore their MEVA II site equipment.

Overview: This training familiarizes Member State personnel with the MEVA II network and to aid in troubleshooting/problem resolution of the network.

Training Outline

1. Introduction
 - MEVA II Network Overview
 - Types of Communications
 - MEVA II Network Diagram
 - MEVA II System Components
2. Network Operation
 - How Communication is Established
 - MEVA II Network Synchronization Diagram
 - Traffic Bursts Diagram
 - Burst Types
 - Linkway TDMA Architecture
 - Linkway Protocols and Services
3. Troubleshooting Concepts
4. Preventive and Corrective Maintenance
 - Reporting an Outage
 - Scheduling downtime for maintenance
 - RMA and shipping
 - Network Management
5. Procedures
 - General
 - Test Equipment Setup and Use
 - Antenna Peak and POL
 - Sealing Connectors
 - Loading boot files in the Linkway 2100

- Preventive Maintenance
 - ODU's
 - IBUC/PSUI Grounding Recommendations
 - Periodic Inspection of the Prodelin Antenna
 - Monthly Maintenance
 - Every Six Months
 - Annual Maintenance
 - Corrective Maintenance
 - Fault Isolation of ODU's
 - Component Replacement
 - Recovery Testing
 - Interference Testing
6. Acronyms and Abbreviations
7. Applicable Documents

MEVA II Introduction

Overview

MEVA II is a TDMA (Time Division Multiple Access) satellite-based frame-relay network used for Air Traffic Control (ATC) in the Caribbean and Central America region. It provides voice and data communication between control towers in the following 15 locations:

- Miami, FL (the main hub and FAA site)
- Woodbine, MD (the alternate hub)
- Georgetown, Cayman Islands
- COCESNA (Teguciagalpa, Honduras)
- Panama City, Panama
- Havana, Cuba
- Port-au-Prince, Haiti
- Kingston, Jamaica
- Santo Domingo, Dominican Republic
- Freeport, Bahamas
- Nassau, Bahamas
- San Juan, Puerto Rico (an FAA site)
- Phillipsburg, St. Maarten
- Curacao, Netherland Antilles
- Oranjestad, Aruba

The MEVA II network is a hybrid network using both full mesh and hub & spoke topologies. The voice portion of the network is configured as full mesh, which gives the ability for any site to talk to any other site. The data portion is configured as hub & spoke where Miami FL is the hub and the 13 remote sites are the spokes.

The data part of the network handles flight plan and weather information which is exchanged between the remote sites of the MEVA II and the Miami hub. The Miami hub connects to the AFTN (Aeronautical Fixed Telecommunication Network) network that is managed in Atlanta, GA. The AFTN uses the X.25 protocol to route the information to and from the remote sites. The AGS equipment provides a path to and from the remote sites using lower level protocols, which are transparent to the higher level X.25 protocol.

There is also an alternate hub at the SES Woodbine, MD teleport that is used for disaster recovery if problems occur at the FAA Miami primary hub.

Types of MEVA II Communications

The two types of communications used by the MEVA II network are data and voice.

DATA

Data is a dedicated type of communications; it is always connected. Data uses 9.6K synchronous serial communications. It is used to exchange AFTN/NADIN (NAS Aeronautical Digital Information Network) traffic. All remote MEVA II sites use data communications except for San Juan, Puerto Rico.

VOICE

The two types of voice communications used by the MEVA II network are:

- Switched voice (4-digit dial plan) - All remote MEVA II sites use switched voice.
- Voice shout-down - The far-end ATC picks up the line for immediate talking and no dialing is required. This line always available. Voice shout-down communication circuits are less common than switched voice circuits.

MEVA II Network Diagram

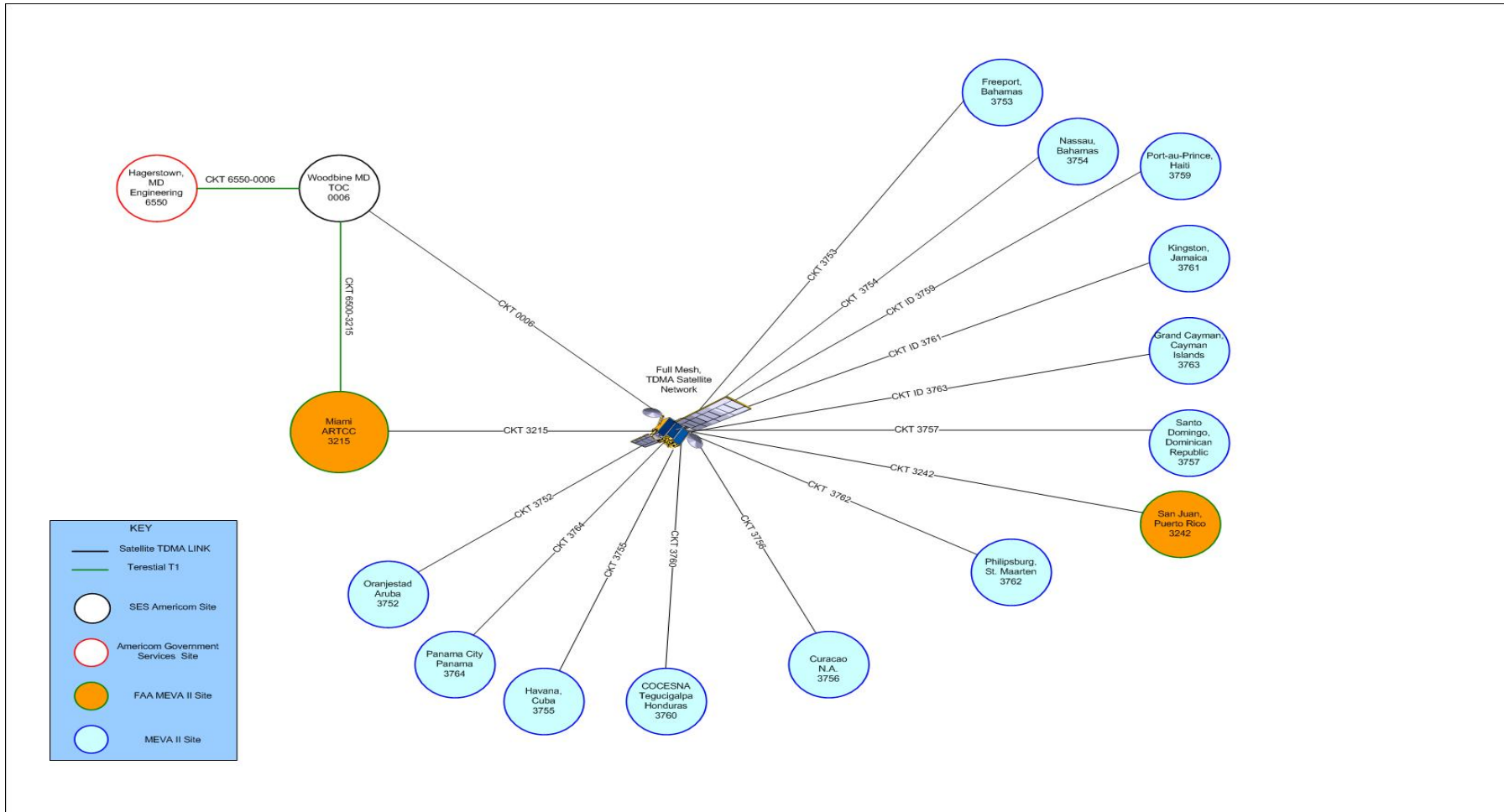

MEVA II System Components

Each MEVA II remote network site consists of outdoor and indoor equipment that maintains communication between the ATCs. The outdoor equipment includes the VSAT earth (Very Small Aperture Terminal), LNB (Low-Noise Amplifier Block-Down Converter), and a BUC (Amplifier Block-Up Converter). The indoor equipment includes a rack containing each piece of equipment.



Note: Regarding the safety of MEVA II components, normal electronic procedures according to mobile practices should apply.

Outdoor Equipment

The Outdoor Equipment of the MEVA II network consists of the VSAT, BUC, LNB, and the AST 5100. All outdoor units are weatherized and designed to mount outdoors, in most climates, and on most satellite earth station antennas.

The Interfacility Link (IFL) between the ODU's (Outdoor Units) and the Linkway 2100 L-band modem utilizes 950 to 1750 MHz (L-Band) as the interface frequency. This allows transmission and reception over the entire satellite band as opposed to a single transponder. The L-band IFL also carries an assortment of other signals (10MHz, DC voltage, FSK), simplifying installation and reducing costs.

VSAT

Most MEVA II remote sites use the Prodelin 3.8M C-band antenna. However, two sites use the Andrew 4.5M C-band antenna. The main components of the VSAT satellite antenna are the parabolic reflector (antenna), Co-Pol (polarization) feed, feed support arm, azimuth and elevation adjustment.

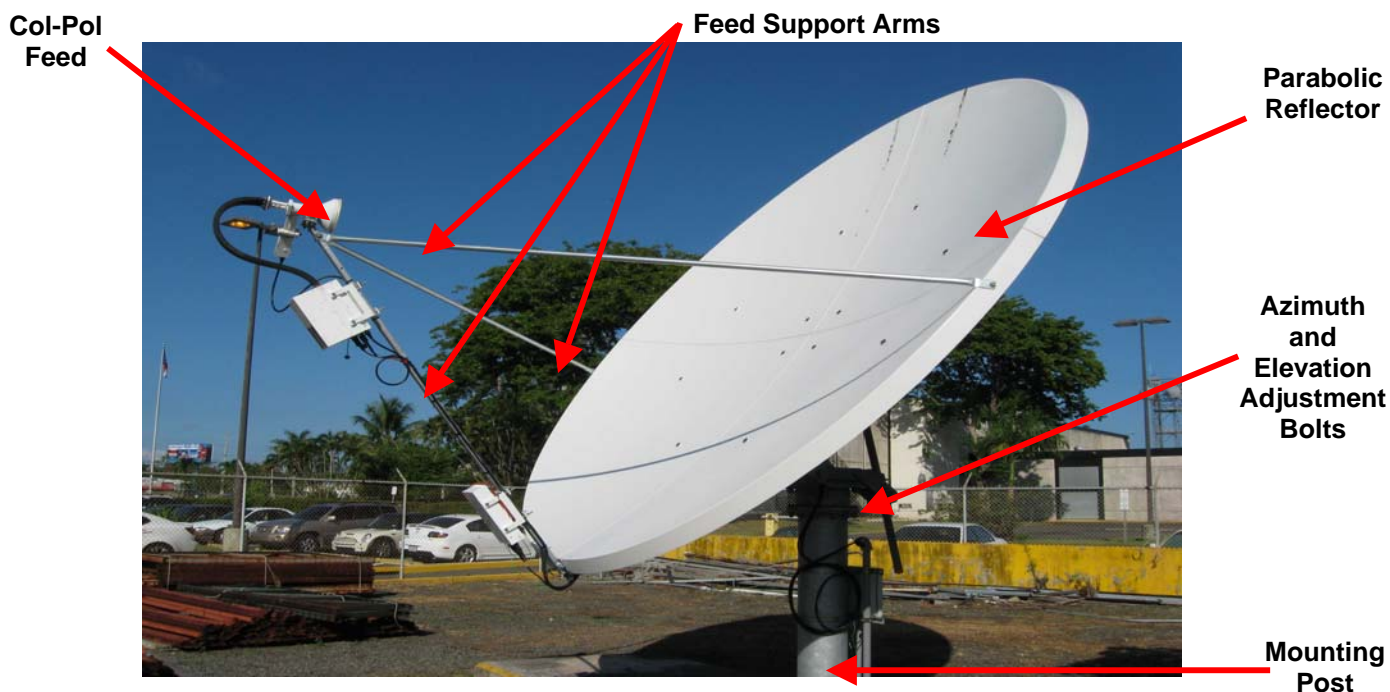

Parabolic Reflector

This is the largest part of the VSAT. This antenna is used to focus and increase the signal strength into a point where the feed is mounted.

Co-Pol Feed

The MEVA II feed is a linear co-pol (polarization) feed that receives and transmits in the vertical polarity on the IS-1R satellite.

Azimuth and Elevation Adjustment bolts

The azimuth and elevation adjustment bolts make fine adjustments to point the satellite antenna towards the satellite.

Feed Support Arm

The feed support arm supports the reflector to the parabolic focal point.

Mounting Post

The mounting post mounts the satellite antenna to the ground.

LNB

The MEVAII Network uses a Norsat 3020N LNB. This LNB has an N Type female connector that connects to the IFL coaxial cable. The LNB requires an external 10 MHz reference signal that is provided by the AST 4100. The 10 MHz reference will be provided by the Linkway 2100 after the first maintenance visit.

The C-band LNB comes standard with a maximum noise temperature of 450K. The LNB houses the Low Noise Amplifier (LNA), the RX conversion circuitry, and the L-band IF Interface (de-mux). The interface with the LNB consists of a 75 Ω coaxial cable that carries the L-Band receive signal, 10 MHz reference oscillator signal, and DC power.

The LNB receives the C-Band transmission from the satellite. The LNB then converts the C-band to an L-band that inputs into the Linkway 2100 modem.

The LNB comes in a single weatherproof housing suitable for antenna feed mounting.

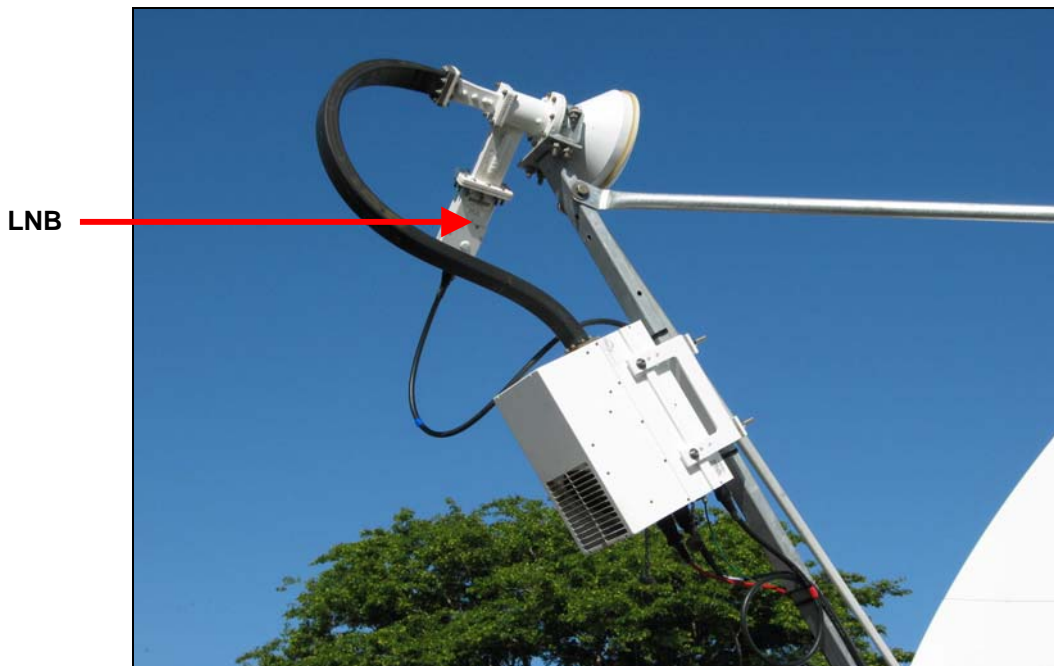

BUC

The Terrasat 40-watt C-band IBUC is used at the MEVA II remote sites. The Terrasat IBUC is both a BUC and a 40 WATT SSPA (Solid State Power Amplifier) all in one package. The 48 VDC (Volts Direct Current) is provided to the IBUC by a separate 600 watt PSU (Power Supply Unit) just below the IBUC on the feed support arm.

The PSU converts the universal AC input (100-260VAC) to 24 or 48 VDC, depending on the option ordered, to power the IBUC. The PSU comes in a single weatherproof housing suitable for antenna mounting and can power all of the Terrasat IBUC's. The outdoor PSU can be ordered with an optional external cooling fan in a fan housing.

The indoor Linkway 2100 modem inputs the L-band transmission into the IBUC. The IBUC then converts the L-band to C-band for satellite transmission. The rated power of the BUC is specified at P1dB at the output waveguide flange connector. The BUC comes in a single weatherproof housing suitable for antenna or feed mounting.

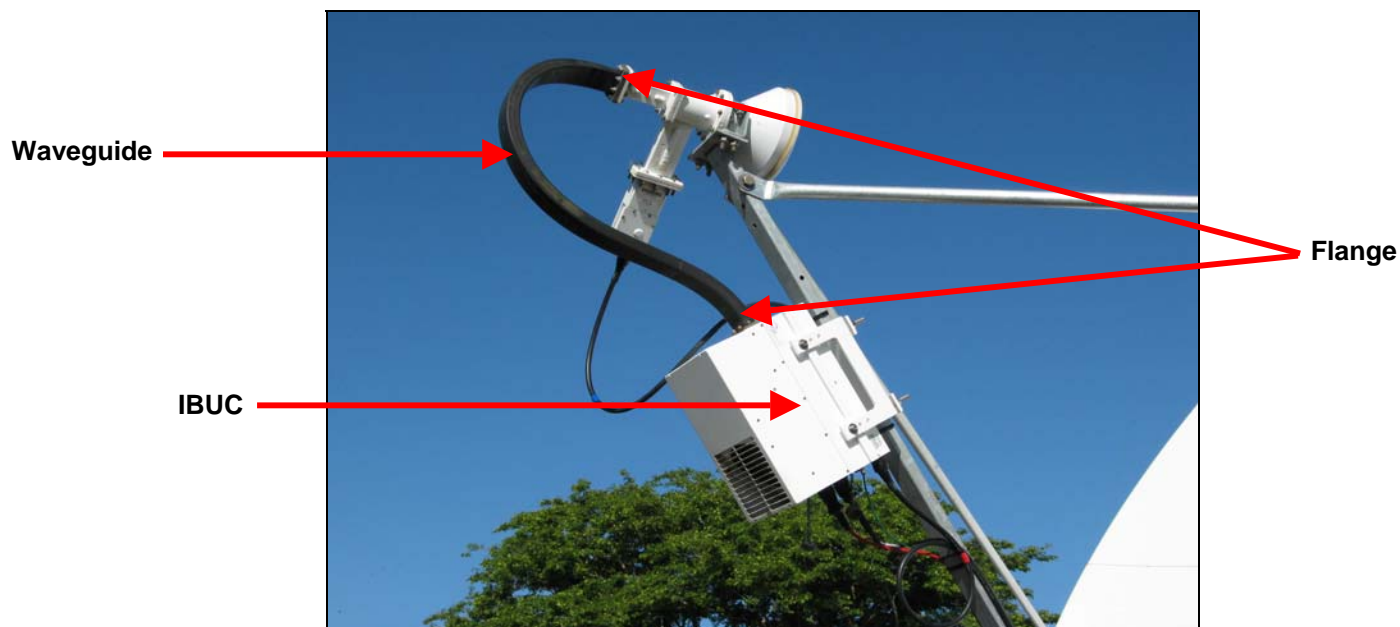

Note: The C-band IBUC is available in 5,10,20, 25, 40, and 60 watt configurations.

IBUC Components

The IBUC houses the IF Interface (de-mux), the UPC (UpConverter), the M&C card, a DC to DC converter and associated circuitry, and SSPA assembly. The C-band IBUC also has an external cooling fan assembly. The input interface to the IBUC consists of a 50 Ω coaxial cable that carries the L-Band transmit signal, 10 MHz reference oscillator signal, DC power and bi-directional M&C FSK signals.

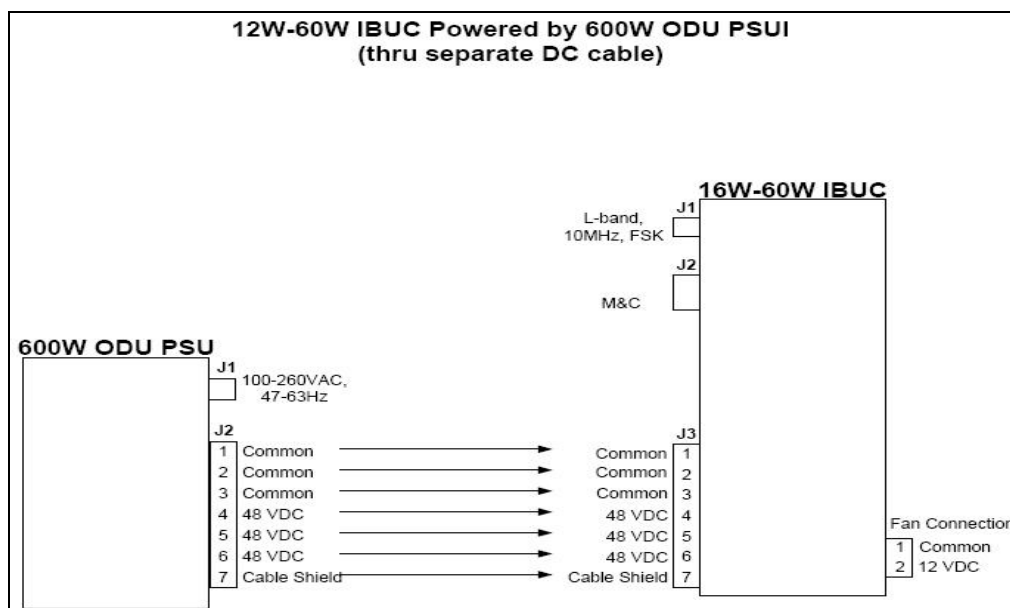

DC Supply

For lower power units (10W and below) DC power can be applied through the L-band input N-connector (J1) or through the external power connector (J3). DC power for the higher power units (12W and above) is applied through the DC input 7-pin circular connector (J3). The high power units cannot accept the DC input through the L-band input N-connector (J1) due to the higher current draw.

In all cases, the DC power input source is automatically sensed and protected so that an input to one connector does not result in an output to the other connector.

If for some reason a DC power source is applied to both connectors simultaneously, the protection circuitry prioritizes which DC power source will be utilized. The priority connector is the DC input 7-pin circular connector (J3). In addition to the two possible connector inputs for the DC supply, there are also options for the DC supply voltage.

For all lower power units (10W and below), options for 24VDC or 48VDC supplies are available. The operating voltage range for the 24VDC option is 20 to 28VDC whereas the operating voltage range for the 48VDC option is 37 to 59VDC. This option must be selected at the time of order. For all higher power units (12W and above) the standard configuration is 48VDC.

Monitor and Control

The term “Intelligent Block Upconverter” refers to the advanced features and monitor and control capabilities of the IBUC product. It also provides extensive monitoring and control through a menu of software commands and alarms providing access to the numerous operating parameters and features available in the unit. Access to features and M&C is provided via several methods including TCP/IP, RS232 (J2 connector) and FSK link via the IFL cable (J1 connector).

Along with internal diagnostics, the IBUC includes the following features:

- AGC (Automatic Gain Control) - The IBUC continuously monitors output. If a change in the TX (Transmit) output level is detected, the input to the IBUC is checked to see if it has changed. If the input has not changed, the IBUC adjusts the gain of the system in 0.1 dB steps to maintain a set gain value.
- ALC (Automatic Level Control) - Similar to the AGC system, the IBUC monitors output and adjusts gain to maintain a constant output level.
- Burst Operation - Allows the user to operate in burst mode. The IBUC reports average output power when in burst mode.
- Alarm History - A log of all alarms that occur with date and time stamps is maintained. Simplifies troubleshooting of the system especially if an intermittent problem occurs.

The IBUC is also fitted with a multi-function LED (Light Emitting Diode) for visual status indications.

RF Signal Flow

The L-band input to the IBUC is through the input N-connector J1. The required inputs to the IBUC consist of a 10MHz sinewave signal between +3 and –8 dBm (Decible referenced to 1 milliwatt) as well as the L-band signal at less than or equal to –20 dBm. In addition to the 10MHz level requirements, the 10MHz signal must meet minimum phase noise requirements. The J1 input may also include a DC voltage and/or FSK signal as described above. The input from J1 is routed to the demultiplexer circuitry where the various signals are split off and routed to the appropriate circuits within the IBUC. The DC voltage is routed to the DC/DC power supply and the FSK signal is routed to the M&C card.

The 10MHz signal is routed to the phase locked loop where it is multiplied. The output of the multiplier is routed to the phase detector circuitry where it is compared with the phase of the DRO (Dielectric Oscillator) signal and generates a voltage that is proportional to the phase differential. This voltage is applied as a control voltage to the DRO to adjust its frequency. The DRO has been optimized for phase noise at a single frequency based on the frequency band of the IBUC that has been ordered. The output of the DRO is amplified and routed to the mixer.

The L-band signal that is split off in the demultiplexer circuitry is filtered and amplified and then routed to the temperature compensation circuitry. The temperature compensation circuitry has been calibrated so that the IBUC gain does not vary by more than 3 dB (decibel) over the specified operating temperature of the IBUC.

The output of the temperature compensation circuitry is amplified and routed to the mixer. The mixer mixes the L-band signal with the DRO signal to “upconvert” to the appropriate RF signal based on the frequency band of the IBUC. The RF signal is then filtered, amplified and routed through an isolator for reverse power protection. The RF output is detected for use by the M&C circuitry. The IBUC gain has been calibrated so that at maximum gain (a -30 dBm input) results in rated power output (P1dB) of the IBUC. To operate at lower power levels, reduce the input to the IBUC. The output of the IBUC is a WR137 waveguide or optional N-type connector for C-band.

AST 5100

An AST 5100 is an outdoor box that serves as an access point for technicians. It features AC power, Ethernet, and telephone port connections. The AST 5100 aids in onsite troubleshooting at the local site.

AST 5100



Indoor Equipment

The Indoor Equipment of the MEVA II network consists of the remote rack, which includes the Memotec CX960e, the Linkway 2100, AST 4100, AST 3100, Liebert UPS, and Cisco Ethernet switch.

The indoor PSUI converts the universal AC input (100-260VAC, 50-60Hz) to 24 or 48 VDC, depending on the option ordered, to power the IBUC. The 200W indoor PSUI includes a multiplexer to add the DC voltage to the L-band IFL to power the 2W through 10W BUC's.

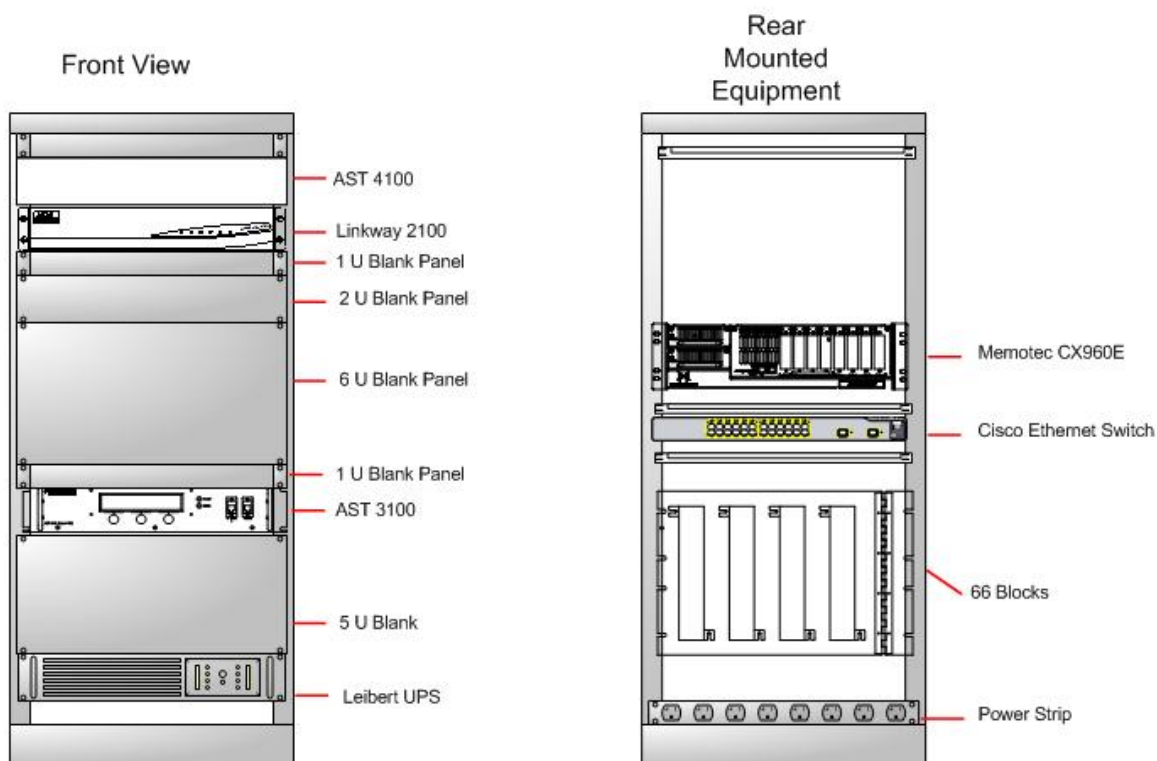

MEMOTEC CX960E

The CX960e chassis consists of a rack mountable metal frame which houses a hot-swappable CPU module, two hot-swappable power supply modules, two cooling fans, and two power entry modules.



Memotec CX960e

The Memotec system consists of the following modules:

- CPU
- I/O Cards
- Power Supply

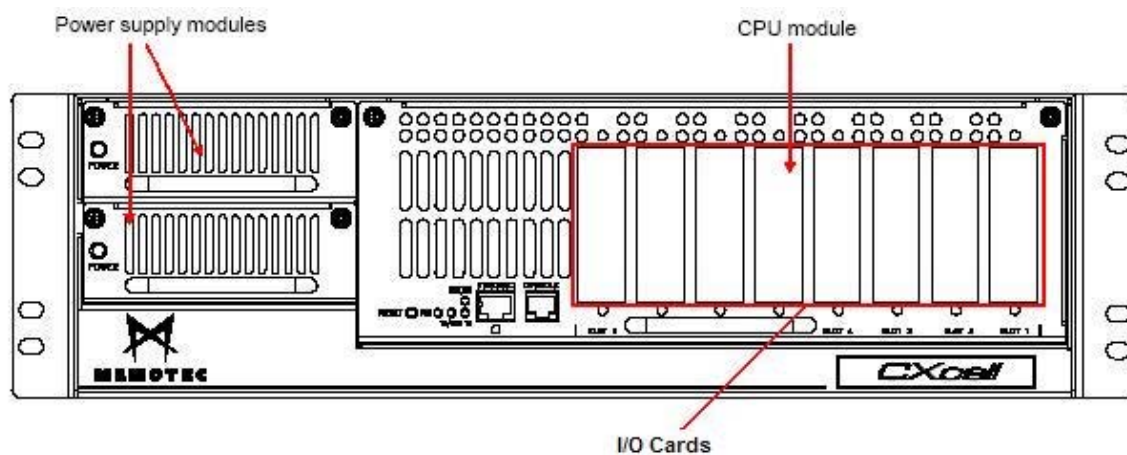

Memotec Modules

CPU MODULE COMPONENTS

The CPU module houses the motherboard that holds all integrated circuits and other components required to achieve I/O card interoperability.

Front Panel

The CPU module slides horizontally into the CX960e chassis. When installed properly, it slides back until the motherboard makes firm contact with the backplane. The backplane provides the connections necessary to power the motherboard via the power supply module.

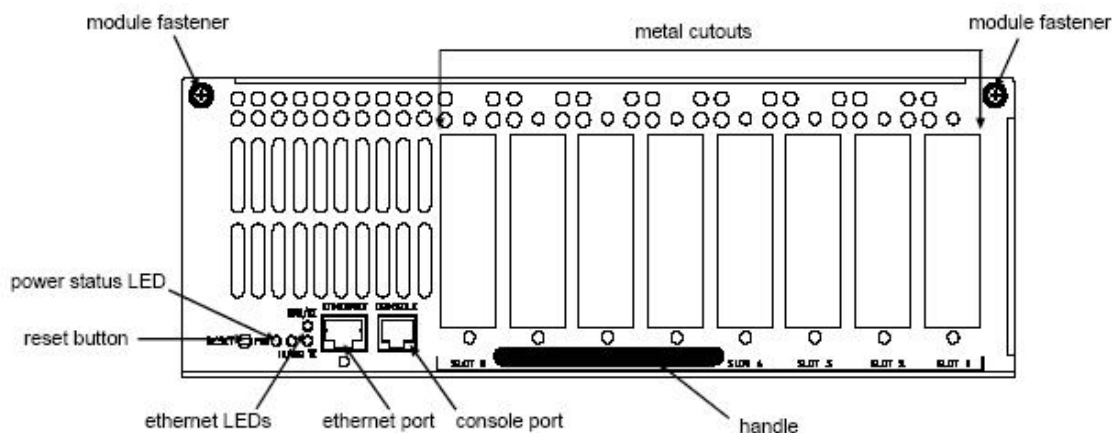

The module's front panel has two module fasteners: one on the upper right-hand corner, and one on the upper left-hand corner. They keep the CPU module firmly in place, and keep proper contact with the backplane. For more detailed instructions, see *Inserting/Removing the CPU or Power Supply Modules* in the next section.



Important: Slide the CPU module all the way in, pushing it firmly to insure it makes contact to the backplane. It is also necessary to tighten the module fasteners once the CPU module is in place.

The front panel consists of:

- Reset Button - Mechanically resets the unit. Any unsaved software configuration changes are lost if you press this button.
- Power LED (Light Emitting Diode) - A green light that indicates the system status. The LED is lit when the unit is on. The LED is not lit when the unit is off or not functioning properly.

- Ethernet Port - There is a 10/100 Mbps (Megabyte per second) Ethernet port integrated into the CPU module. This port autosenses data transmission speeds of 10 or 100 Mbps and autosenses full-duplex or half-duplex capability.
- Ethernet LEDs -The Ethernet port has three LEDs labeled LINK/RX, TX, and 10/100. The following table lists the indications associated with the LED states.

LED	Colour	LED State	Indication
LINK/RX	green	On	The receive port is UP.
		Off	The receive port is DOWN.
		flashing	Data is being received.
TX	green	On	Data is being transmitted.
		Off	Data is not being transmitted.
10/100	green	On	Data is transmitted at 100 Mbps.
		Off	Data is transmitted at 10 Mbps.

- Ethernet Port Signal Handling - The following table describes the signal-to-pin relationships for both 10BaseT or 100BaseT.

Signal	Pin No.
RX+	1
RX-	2
TX-	3
not connected	4
not connected	5
TX+	6
not connected	7
not connected	8

- Console Port - The front panel has a female RJ-11 type connector labeled CONSOLE for the console port. You can access the CX960e controlling software by attaching a terminal or a PC running asynchronous emulation software directly to this connector with the RJ-11 type (male) to DB-9 (female) cable shipped with the unit. The asynchronous parameters for the console port are factory-set. The terminal or PC parameters should be set to match:

Character Length: 8 bits/character

Stop Bits: 1 bit/character

Parity: None

Speed: 9600 bps

- Metal Cutouts - The front panel features eight metal cutouts, labeled *slot 8* to *slot 1*, where the I/O cards may slide into their slots, and to where the faceplate will be fastened.



Note: Some I/O cards are too large to be inserted through the front cutout. Refer to *I/O Card Installation* on page 37 section for instructions.

When a slot has no I/O card, it should remain covered with a blank metal plate to limit dust accumulation and electromagnetic radiation. When an I/O card has been mounted in a slot, the connector plate on the I/O card replaces the panel's blank metal plate.

To ensure the I/O cards are inserted properly into their slots, **always** screw the connector plates to the panel. Screwing in the connector plates secures proper contact, and dramatically reduces the occurrence of error.

Inserting/Removing the CPU or Power Supply Modules

The CPU module and power supply modules on the CX960e are hot swappable. To insert and remove any of these modules, refer to the following procedures:

- Ground yourself to protect the I/O cards from ESD (Electrostatic Discharge).
- Make sure the CX960e is properly grounded using the following procedures:
 1. Hold the module by the handle. Align the side edges of the module with the plastic guides inside the chassis.
 2. Slide the module all the way in, pushing it in firmly, insuring that it makes firm contact to the backplane.
 3. Tighten the module fasteners. The modules have two fasteners: one on the upper right-hand corner, and one on the upper left-hand corner.
 4. To remove the modules, loosen the module fasteners, and pull the module out of the chassis.
 5. In order to perform any work inside the CPU module, lay the CPU module flat on a horizontal surface.
 6. Follow steps 2 - 5 to put the module back into the CX960e chassis.



Note: For an AC-powered chassis, the three-wire cable is connected. For a DC-powered chassis, the frame ground is connected.

Motherboard

The motherboard lines the bottom of the CPU module. The various components of a module's motherboard are organized into three functional sections:

- Processing
- I/O (Input/Output)
- Power

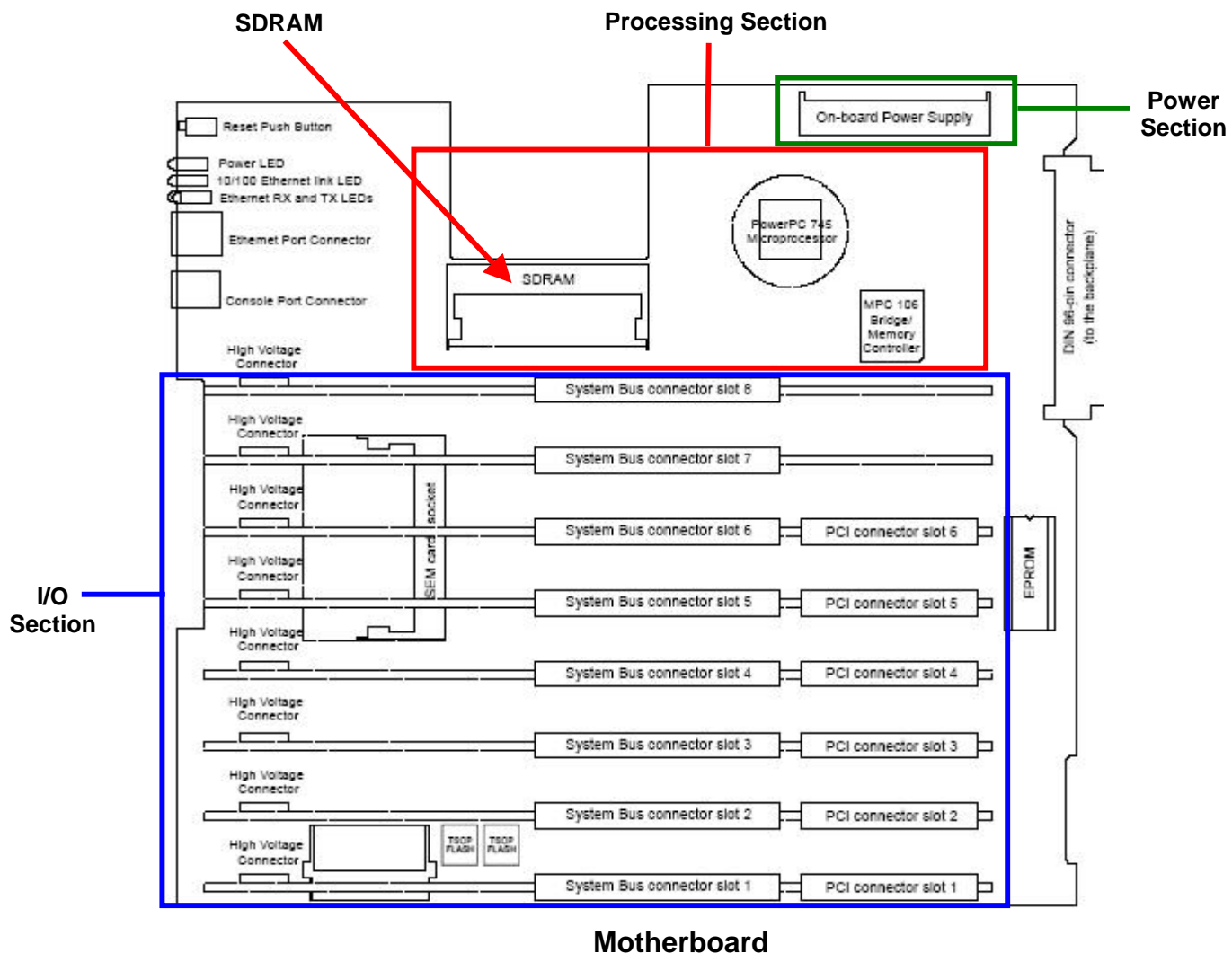

Motherboard

Processing Section

- CPU - The PowerPC 745, located at U17, is a 333 MHz high performance RISC microprocessor featuring high instruction and data throughput, and a system bus clock speed of 65.536 MHz.
- Bridge/Memory Controller - The MPC106, located at U25, acts as the interface between the central processor (PowerPC 740), the main memory, the PCI bus, and the system bus.
- Communications Controller - The MC68MH360, is a Quad Universal Integrated Communication Controller (QUICC) containing four SCC (Serial Communication Controllers) which serve card I/O slots 1 to 4. The device operates at 32.768MHz. It is located at U10.



Note: An additional QUICC is required when certain I/O cards are installed in I/O slots 5 to 8. This QUICC is located on the Serial Expansion Module (SEM) which is a plug-in card inserted into a 144-pin SODIMM (Small Outline Dual Inline Memory Module) connector on the motherboard (J11).

- Memory - The following table summarizes the basic and upgraded memory configurations that can be installed on the motherboard.

Function	Memory Type	Basic Configuration	Upgraded Configuration	Package	Location
Boot code	EPROM	128Kx8 bit	-	DIP 32-pin	U33
Application code and configuration data	FLASH	2X 2Mx8 bit	-	TSOP	U53, U54
Application code and data buffers	SDRAM module	8Mx64 bit (64 MB)	16Mx64 bit (128 MB)	SODIMM 144-pin	U2

Summary of Memory Configurations

RAM Installation

You may need to increase the motherboard's SDRAM (Synchronous Dynamic Random Access Memory, shown in the previous diagram of the motherboard.) Additional memory can be installed in the SODIMM connector at U2. To install new SDRAM, refer to the following procedures.



Note: These procedures assume that the CPU module has been removed. (See *Inserting/Removing the CPU Module or Power Supply Modules* in the previous section.)

1. Ground yourself to protect the I/O cards from ESD (Electrostatic Discharge).
2. Insert the upgrade module in the vacated socket (U2).
3. Reinsert the CPU module (See *Inserting/Removing the CPU Module or Power Supply Modules* in the previous section) or proceed with other work inside the module.

I/O Section

The motherboard contains three sets of connectors, each one dedicated to I/O card interconnection to one of the following buses:

- **System Bus** - In the middle of the motherboard are eight 120-pin card-edge connectors (located at J12 through J19). They seat the I/O cards in their slots and connect them to the system bus. These connectors support the CPU bus, a synchronous serial bus and a subset of the TDM bus H.110.
- **PCI Bus** - Six 80-pin edge connectors are provided to connect the 32-bit Peripheral Component Interconnect (PCI) bus to card slots 1 to 6. The PCI bus enables the high-speed transfer of data between the six card slots and the motherboard's CPU.
- **High Voltage Bus** - Voice I/O cards have additional power requirements which are met through the high voltage bus. This bus carries -48 VDC from power supply module to the 6-pin high-voltage connectors of each I/O card slot.

Power Section

The motherboard receives +5VDC and +12VDC from a power supply mounted within the chassis. Two voltages are derived from the +5VDC through voltage regulators: they are +3.3VDC and +2.5VDC. The +2.5VDC provides power to the core of the PowerPC.

I/O CARDS MODULE COMPONENTS

The expansion slots are numbered from 'SLOT 1' to 'SLOT 8'. MEVA II uses the following I/O cards in those slots:

- **V.24** (also known as RS 232) - A 9.6 K synchronous serial port which provides access the AFTN (Aeronautical Fixed Telecommunication Network).
- **V.35 H** - The main Frame-Relay link to the Linkway 2100. The port speed runs at 2.048 Mbps (megabits per second).
- **DAV** (Dual Analog Voice) I/O card. FXS (Foreign Exchange Station) and E&M (Ear and Mouth) cards plug into LID (Line Interface Driver) sockets on the DAV I/O card. The FXS port is used to provide the switched voice while the E&M card is used at sites with voice shutdown lines.

The front panel of the CPU module features a console port where a PC or terminal may access the unit (and its I/O cards) for software configuration.

The CPU module also features an on-board Ethernet port, which provides an extra LAN connection. The Ethernet port has three LEDs indicating LAN traffic status.

V.24 Serial I/O Card

Important components on the V.24 Serial I/O Card include:

- Edge connector
- Port connector plate
- Signal LEDs
- Port configuration jumpers

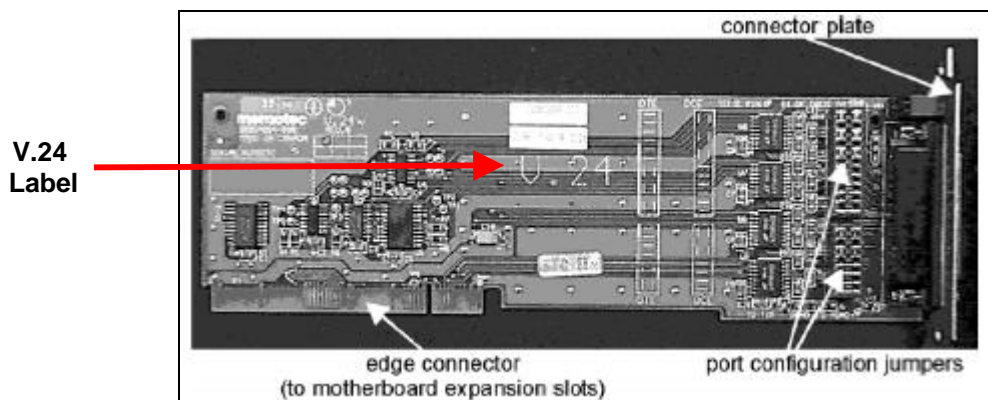

V.24 Serial I/O Card



Note: The V.24 Serial I/O Card has a "V.24" label.

The edge connector fixes the card to any one of the motherboard's expansion slots 1-8. The connector plate fixes the female DB-25 connector to the chassis' rear panel with two Phillips-head screws and limits dust accumulation and electromagnetic radiation.

- Cable - The V.24 Serial I/O Card connects to external devices through a separately-ordered three-meter (10 ft.) straight through shielded cable (part no. CBLA0006-010 with 4-40 screws and number CBLA0006-110 with M3 screws) with a male DB-25 connector (ISO 2110) at each end. If using cables other than those supplied by Memotec, ensure that the capacitance does not exceed 1880 pF. This can be calculated from the cable manufacturer's specifications of pF/Ft (capacitance per foot), which differs from one cable to the next.

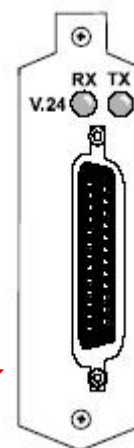

V.24 Connector Plate

- Speeds Supported by the V.24 Serial I/O - MEVA II operates at 9.6 K synchronous serial.
- DCE Interface Configuration - The V.24 Serial I/O Card's port is configured as a DCE device. The DCE strapping has been silk-screened on the I/O card to aid in configuration.

Two jumper banks socketed at U11 provides DCE configuration. Permanent metal bands on the top surface of the jumper banks strap signals according to DCE requirements. Rotating each jumper 180° changes the port from one kind of device to the other, as illustrated below.

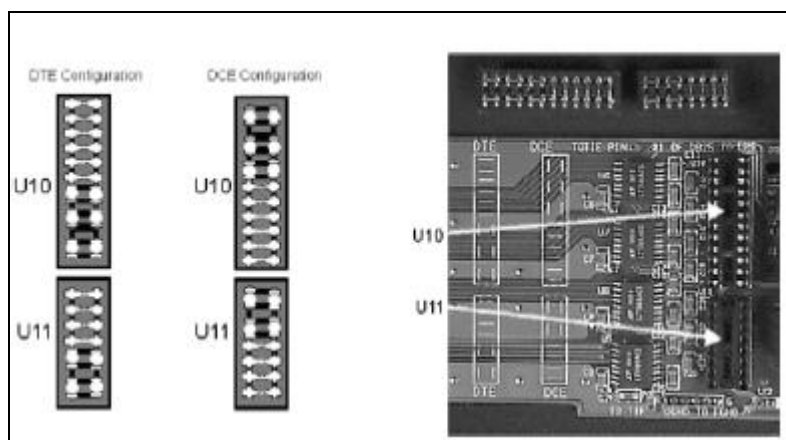

V.24 DCE/DTE Configuration Jumpers

- V.24 Serial I/O Card Signal Handling - Signaling through the V.24 Serial I/O Card's port complies fully with the ITU-T's (International Telecommunications Union, section CCITT) V.24 and the EIA-232D (RS232) standards for a DB-25 connector.

V.24 Signal	Circuit Function	EIA	CCITT	DB-25 Pin No.	Signal DTE	Direction-DCE
PG	Protective Ground (Shield)	AA	101	1	GND	GND
TXD	Transmitted Data	BA	103	2	Out	In
RXD	Received Data	BB	104	3	In	Out
RTS	Request to send	CA	105	4	Out	In
CTS	Clear to Send	CB	106	5	In	Out
DSR	Data Set Ready	CC	107	6	In	Out
SG	Signal Ground	AB	102	7	GND	GND
DCD	Data Carrier Detect	CF	109	8	In	Out
	*Reserved			9	not used	not used
	*Reserved			10	not used	not used
	*Unassigned			11	not used	not used
*SCD	Secondary Received Line Signal Detector	SCF	123	12	not used	not used
*SCTS	Secondary Clear to Send	SCB	121	13	not used	not used
*STD	Secondary Transmitted Data	SBA	118	14	not used	not used
TXC	Transmit Timing	DB	114	15	In	Out
*SRD	Secondary Receive Data	SBB	119	16	not used	not used
RXC	Receive Timing	DD	115	17	In	Out
LL	Local Loopback	LL	141	18	Out	In
*SRTS	Secondary Request To Send	SCA	120	19	not used	not used
DTR	Data Terminal Ready (DTE Ready)	CD	108.2	20	Out	In
RL	Remote Loopback/Signal Quality Detector	CG	110	21	Out	In
RI	Ring Indicator	RL	140	22	Out	In
DRS	Data Rate Selector	CH	111	23	Out	In
EXTC	Terminal Timing	DA	113	24	Out	In
TM	Test Mode	TM	142	25	In	Out

Signal Pin-Outs for V.24 I/O Port



Note: Pins designated with * are not used in the present V.24 interface.

- V.24 Serial I/O Card Power Consumption - Power consumption for the V.24 Serial I/O Card is 0.35 Watts (1.2 BTU/hr).

V.35 H Serial I/O Card

Important components on the V.35 Serial I/O Card include:

- Edge connector
- Port connector
- Signal LEDs
- Port configuration jumper

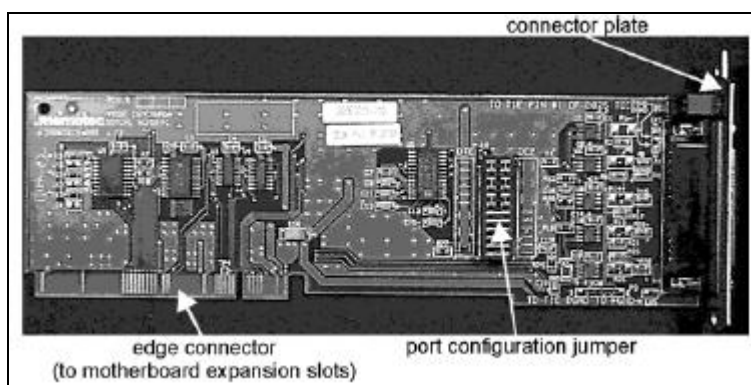

V.35H Serial I/O Card

The edge connector fixes the card to any one of the motherboard's expansion slots 1-8. The connector plate fixes the female DB-25 connector to the chassis' rear panel with two Phillips-head screws and limits dust accumulation and electromagnetic radiation.

- Cable - The V.35 Serial I/O Card connects to external devices either of two separately-ordered cables:
- Three-meter (10 ft) shielded, twisted pair cable with a male DB-25 connector at one end and a **male** M-34 block connector at the other (part no. CBLA0014-010)
- Three-meter (10 ft) shielded, twisted pair cable with a male DB-25 connector at one end and a **female** M-34 block connector at the other (part no. CBLA0014-210)

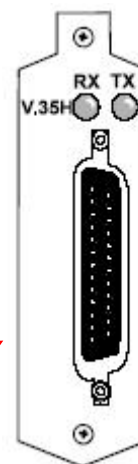

V.35H Connector Plate

- Speeds Supported by the V.35 H Serial I/O - For MEVA II, the V.35 Serial I/O card is set for DTE at 2048 Kps (Kilobits Per Second) synchronous serial.



Note: A clocking speed of 5.0 Mbps is supported when installed in slots 1 or 5 and when connected to Comtech modem equipment.

- DTE Interface Configuration - The V.35 H Serial I/O Card's port is configured as a DTE device. DTE strapping has been silk-screened on the I/O card to aid in configuration.

A jumper bank socketed at U8 provides DTE configuration. Permanent metal bands on the top surface of the jumper banks strap signals according to DTE requirements. The orientation of the jumper bank determines whether the port will be DTE or DCE. Rotating each jumper 180° changes the port from one kind of device to the other, as illustrated below.

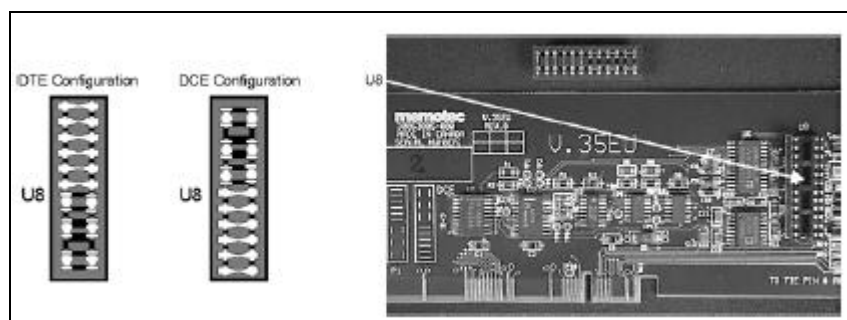

V.35 H DCE/DTE Configuration Jumper

- V.35 H Serial I/O Card Signal Handling - Signaling through the V.35 Serial I/O Card's port complies fully with the ITU-T's V.35 H standard. Signaling, however, occurs through a DB-25 connector rather than an M-34 block connector.

V.35H Signal	Circuit Function	ITU-T	DB-25 Pin No.	Signal DTE	Direction DCE
F. GND	Protective Ground	101	1	GND	GND
TXDA	Transmitted Data (Set A)	103-A	2	Out	In
RXDA	Received Data (Set A)	104-A	3	In	Out
RTS	Request to Send	105	4	Out	In
CTS	Clear to Send	106	5	In	Out
DSR	Data Set Ready	107	6	In	Out
S. GND	Signal Ground	102	7	GND	GND
DCD	Data Carrier Detect	109	8	In	Out
RXCB	Receiver Clock (Set B)	115	9	In	Out
	*Unassigned		10	n/a	n/a
ETXCB	External Transmitter Clock (Set B)	113-B	11	Out	In
TXCB	Transmitter Clock (Set B)	114-B	12	In	Out
	*Unassigned		13	not used	not used
TXDB	Transmitted Data (Set B)	103-B	14	Out	In
TXCA	Transmitter Clock (Set A)	114-A	15	In	Out
RXDB	Received Data (Set B)	104-B	16	In	Out
RXCA	Receiver Clock (Set A)	115-A	17	In	Out
	*Unassigned		18	not used	not used
	*Unassigned		19	not used	not used
DTR	Data Terminal Ready	108	20	Out	In
	*Unassigned		21	not used	not used
RI	Ring Indicator	125	22	In	Out
	*Unassigned		23	not used	not used
ETXCA	External Transmitter Clock (Set A)	113-A	24	Out	In
	*Unassigned		25	not used	not used

Signal Pin-Outs for V.35 Port



Note: Separate A and B signals in the V.35 interface indicate differential pair signals.

- V.35 Serial I/O Card Power Consumption - Power consumption for the V.35 Serial I/O Card is 1.5 Watts (5.15 BTU/hr).

DAV Serial I/O Card

Important components on the DAV Serial I/O Card include:

- Edge connector
- CX960e I/O Bus - Carries the address bus, data bus, and clock and control signals from the motherboard CPU to the DAV I/O card. Transceivers interface the local buses to the CX960e I/O bus. Connection of the I/O bus to the motherboard is through a 120-pin card edge connector.
- DSP (Digital Control Processor) - The core of the DAV I/O card. The DSP uses fixed-point arithmetic suitable of G.729 compression. A 64k x 16 SRAM provides external memory to the DSP.
- AIC (Analog Interface Controller) - Provides bi-directional analog interfaces to the voice SLIM LIDs. The analog interface between the SLIM LIDs and the AICs are differential to minimize noise.

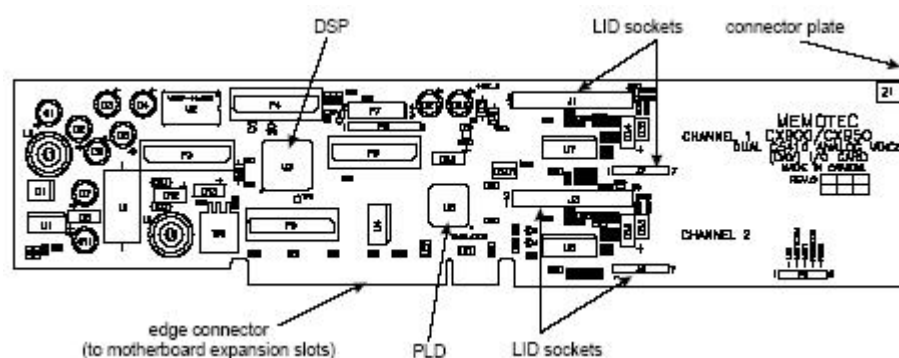

DAV I/O Card (without SLIM LIDs)

- LID (Line Interface Driver) sockets - FXS (Foreign Exchange Station) and E&M (Ear and Mouth) cards plug into LID (Line Interface Driver) sockets on the DAV I/O card.
- PLD (Programmable Logic Device) - Performs three main functions:
 - An interface between the motherboard
 - A logic interface between the DSP and SLIM LIDs
 - A clock distribution circuit for the AICs and the DSP

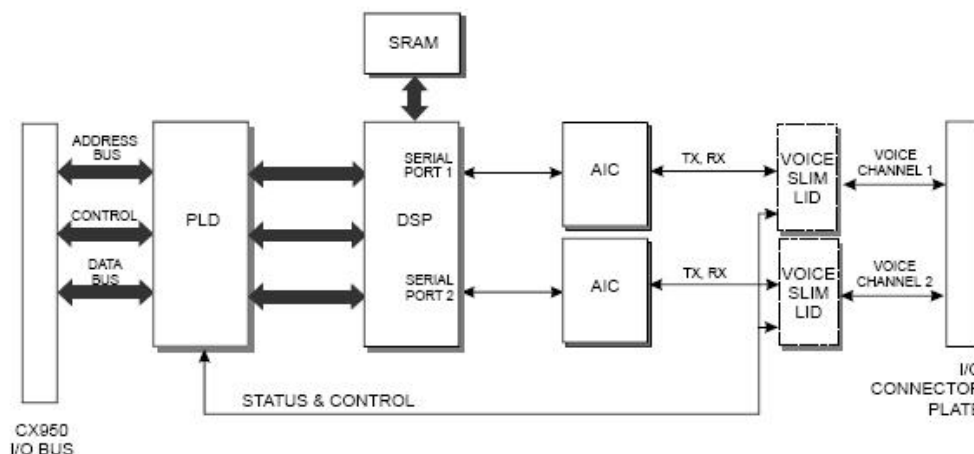

PLD Functions

DAV I/O Connector Plate

- DAV I/O connector plate - features two RJ connectors for external connections to the voice equipment. The RJ connector is an integral part of each SLIM LID.
- Speeds Supported by the DAV I/O - The DAV I/O card supports compression of the 64 Kbps (G.726) or the Kbps (G.711).
- Power requirements:
 - The DAV I/O card is completely powered by the 5V source from the motherboard. The 5V source supplies the 3.3V switching regulator and the 5V analog power filter. The 3.3V source supplies the 2.5V regulator. The DAV I/O does not require the -48V/Ring Generator to be mounted on the motherboard. The telephony power supply is incorporated into the power supply module.
 - The power consumption is 2.1 Watts with SLIM LID.



SLIM LIDs (FXS, E&M)

SLIM LIDs are cards plug into the LID sockets on the DAV I/O card. The SLIM LIDs that are used for the MEVA II sites are:

- FXS: Used to provide the switched voice lines. The FXS provides -48 VDC battery voltage, generates the ring signal and supports Loop Start detection, DID (Direct Inward Dialing), and Flash Hook signaling. MEVA II is configured to use Loop Start detection.
- E&M: Used at MEVA II sites with voice shutoff lines. The E&M 2/4-wire SLIM LID is used for direct connection to a PBX (Private Branch Exchange) using either a two-wire or four-wire voice connection. It can be configured to E&M types I, II, III, IV and V, normal, and reverse. The PBX determines the type of signaling. The following figures illustrate E&M 4-wire Types I, II, III, IV and V. The same diagrams apply to an E&M 2-wire interface except that there is no T1-to-T1 and R1-to-R1 connection.

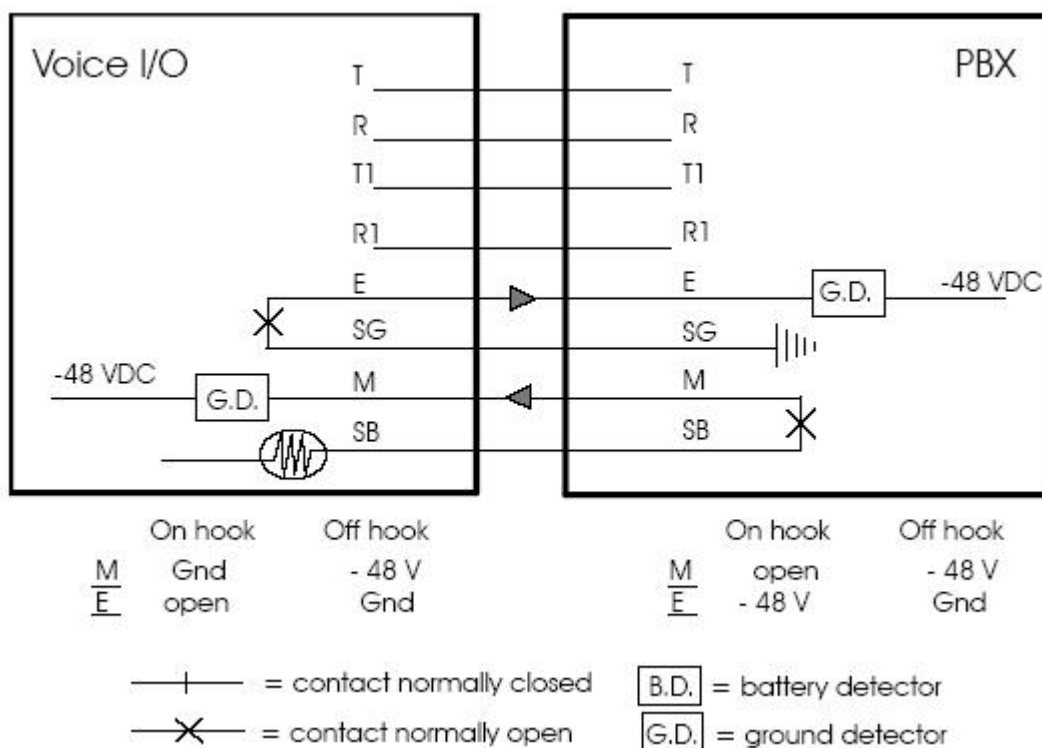

E&M Signal 4-Wire Type II

Configuring Voice SLIM LIDs

Voice SLIM LIDs are hardware configured using jumper banks. In order to reconfigure a voice SLIM LID, the relevant jumper bank(s) must be removed and reinserted in the required location. Jumper locations are silk-screened on the SLIM LID.

E&M 4-Wire

The E&M 4-wire SLIM LID is hardware configurable, with a number of jumper banks. For MEVA II, the E&M 4-wire is used with the following jumper settings:

- 600 Ohm line impedance
- Type II signaling type
- Normal signaling (also known as B side or Channel Equipment side)

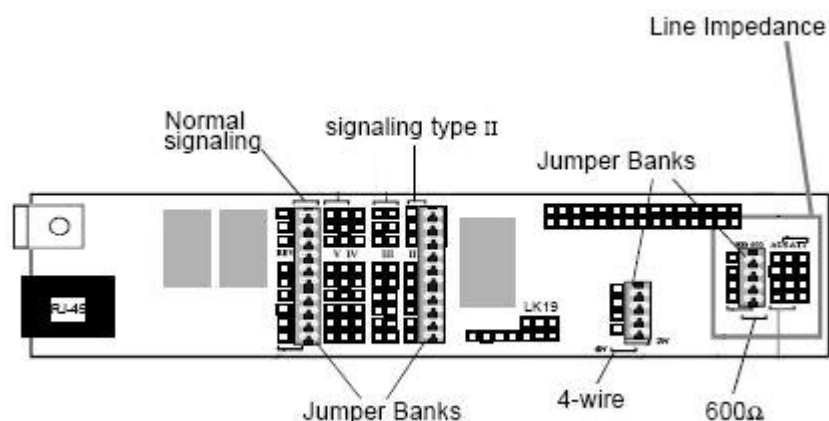

E&M 4-Wire Jumper Settings

FXS

Line impedance is hardware configurable through jumper settings. The jumper bank position for configuring is 600 Ohm impedance for MEVA II.

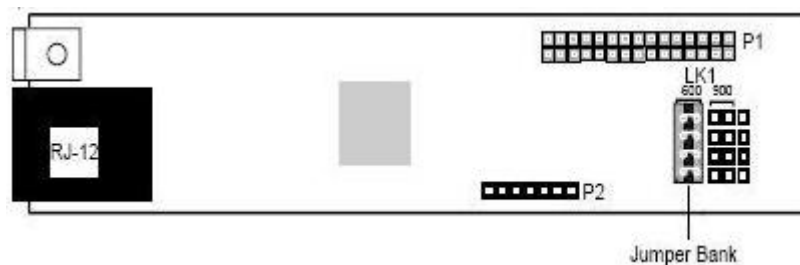

FXS Jumper Settings

Voice SLIM LID Connector Pin Assignments

- FXS - Pins 3 and 4 are used on the Voice Connector Signal Output (RJ-12) for the MEVA II region, as described in the following table:

6-pin	Description
1	
2	
3	Ring
4	Tip
5	
6	

Voice Connector Signal Output (RJ-12)

- E&M - Pins 3 through 6 are used on the Voice Connector Signal Output (RJ-45) for the MEVA II region, as described in the following table:

8-pin	Description
1	
2	
3	Tip 1
4	Ring
5	Tip
6	Ring 1
7	
8	

Voice Connector Signal Output (RJ-45)

SEM Card Installation

Several I/O cards require a SEM (Serial Expansion Module) when they are used in slots 5-8. (See the **Recommended Slot Allocation for the CX960e** table on page 38.) The SEM must be installed prior to adding the I/O Cards. To install the SEM, refer to the following procedures.



Note: These procedures assume that the CPU module has been removed. (See *Inserting/Removing the CPU or Power Supply Modules* on page 21.)

1. Remove the SEM from the packaging.
2. Align the SEM's edge connector with the SODIMM (Small Outline Dual Inline Memory Module) connector at J11 on the motherboard. Make sure the SEM is as far right as possible. The SEM is keyed so that it can only be installed component side up, as shown in the following figure.

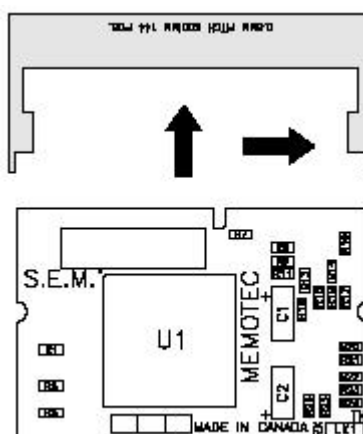

SEM Installation

3. Gently insert the SEM into the SODIMM at about a 30° angle. Ensure that the SEM's connectors are completely in the SODIMM.
4. Gently press the SEM so that it is flush with the motherboard. If the SEM does not lock in place easily, the connectors are probably not completely inside the SODIMM.
5. Reinsert the CPU module (see *Inserting/Removing the CPU or Power Supply Modules* on page 21) or proceed with other work inside the module.

I/O Card Installation

There are two ways of inserting I/O cards into the CPU module

- Front-Loading - Sliding the I/O cards through the rectangular cutouts of the CPU module. The V.24 and V.35 H cards are front-loaded.
- Top-Loading - Loading I/O cards from the top. The DAV card is top-loaded.

Front-Loading I/O Cards

Use the following procedures to install the V.24 and V.35H cards:

1. Ground yourself to protect the I/O cards from ESD (Electrostatic Discharge).
2. Select a slot where you want to install the I/O card. (For assistance, refer to the **Recommended Slot Allocation for CX960e** table on the next page.)
3. Unscrew the selected slot's cover plate from the CPU module's panel, then put the screws aside for later attachment of the faceplate. You should safeguard the cover plate for possible future use.
4. Remove the I/O card with its faceplate from its packaging.
5. Confirm the card's DTE/DCE configuration and, if necessary, unseat its jumpers, rotate them 180°, then reseat them. For the Multi I/O, the suitcase jumpers must also be changed. DTE/DCE jumper orientations are shown in the previous sections (**V.24 I/O Cards** and **V.35 I/O Cards**.)
6. Insert the card through the slot's opening, then align the card's edge connector and high voltage connector over the slot's associated connectors on the motherboard.

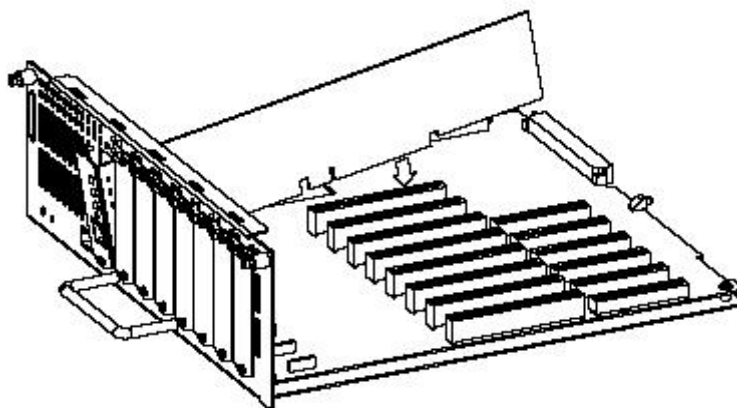

Front-Loading an I/O Card

7. Press the card firmly and gently into place.
8. Fasten the card's face plate to the module's front panel.
9. Repeats steps 1-8 for each I/O card you want to install.
10. Replace the module (see **Inserting/Removing the CPU or Power Supply Modules** on page 21.) or proceed with other work in the module.

I/O Card	Number of ports per card	Max. Speed (per port)	Max. cards of this type	Slot							
				1	2	3	4	5	6	7	8
10/100 Mbps Ethernet PCI	1	autosense 10 or 100 Mbps	2	OK						NO	
Ethernet LAN (10BaseT)	1	10 Mbps	2	OK	NO			OK with SEM	NO		
ATM T1/E1	1	1.544 Mbps or 2.048 Mbps	2	OK						NO	
ATM T3/E3	1	44.736 Mbps or 34.368 Mbps	2	OK						NO	
High Speed Compression	n/a	44.736 Mbps or 34.368 Mbps	1	OK						NO	
V.24 Serial (EIA-232)	1	128 Kbps	8	OK			OK with SEM				
V.35EU	1	2.048 Mbps	8	OK			OK with SEM				
V.35H	1	2.048 Mbps	8	OK			OK with SEM				
X.21	1	2.048 Mbps	8	OK			OK with SEM				
Multi I/O (V.24)	5	128 Kbps	7	OK			OK with SEM				
Universal I/O	5	1.3 Mbps	8	OK			OK with SEM				
DSU/CSU (56K/64K)	1	56K/64K bps	8	OK			OK with SEM				
T1/E1 CSU/DSU	1	1.544 Mbps or 2.048 Mbps	8	OK			OK with SEM				
V.34 Modem	1	28.8 Kbps	7	OK			OK with SEM				
Dual Analog Voice (DAV I/O)	2	n/a	8	OK			BEST				
ISDN BRI-U	1	144 Kbps	7	OK			BEST				
ISDN BRI-S/T Digital Voice	1	144 Kbps	7	OK			BEST				
DIM Data and Voice	2 (with STEP installed)	1.544 Mbps or 2.048 Mbps	8	OK			OK with SEM				

Recommended Slot Allocation for the CX960e

Legend

OK - The I/O card in this slot can be used without any special requirements.

BEST - Use these slots first for the I/O card specified. Filling these slots with the specified I/O cards means that an SEM (Serial Expansion Module) is not required.

OK with SEM - An SEM is required when filling the slot with the specified I/O card.

NO - The specified I/O card cannot be used in these slots.

Top-Loading I/O Cards

Refer to the following procedures to install DAV cards.



Note: These procedures assume that the CPU module has been removed. (See *Inserting/Removing the CPU Module or Power Supply Modules* in the previous section.)

1. Ground yourself to protect the I/O cards from (electrostatic discharge).
2. Select a slot where you want to install the I/O card. (For assistance, refer to the **Recommended Slot Allocation for CX960e** table on the previous page.)
3. Unscrew the selected slot's cover plate from the CPU module's panel, then put the screws aside for later attachment of the faceplate. You should safeguard the cover plate for possible future use.
4. Remove the I/O card with its faceplate from its packaging.
5. Align the card's edge connectors and high-voltage connectors over the slot's associated connectors on the motherboard. Motherboard connectors J12-J19 interconnect the I/O cards to the CX960e I/O bus and J20-J25 interconnect the I/O cards to the PCI bus.
6. Press the card firmly and gently into place.
7. Fasten the card's face plate to the module's front panel.
8. Repeats steps 1-7 for each I/O card you want to install.
9. Replace the module (see *Inserting/Removing the CPU or Power Supply Modules* in the previous section) or proceed with other work in the module.

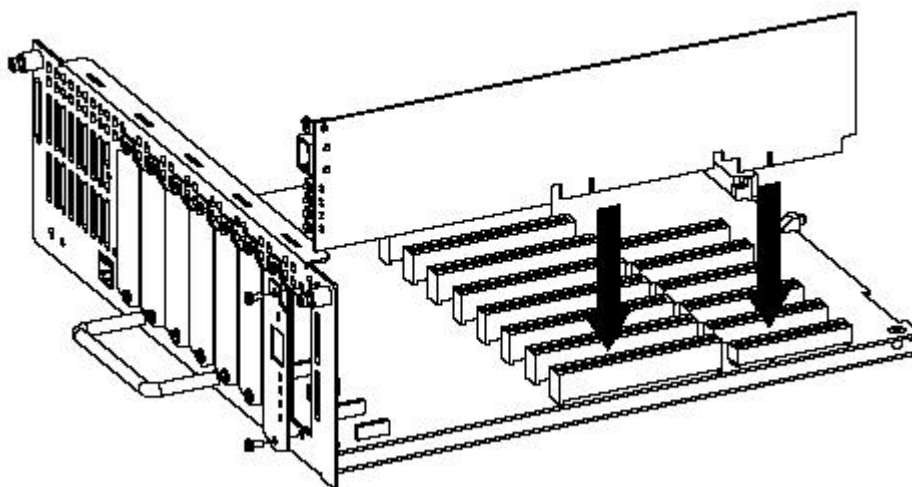

Top-Loading an I/O Card

POWER SUPPLY MODULE COMPONENTS

There are two power supply modules: one main and one redundant. Using redundant power supplies greatly improves the mean time between failure and overall network uptime. The AC unit has a universal-input 85 VAC to 264 VAC power supply. The power supply provides +5V and +12V to the motherboard.

LINKWAY 2100

The Satellite modem for MEVA II is the Linkway 2100. The 2100 is a two-rack unit TDMA modem. All MEVA II sites share the same satellite bandwidth but communicate at different time slots assigned by the NCC (Network Control Center) at the MEVA II hub.

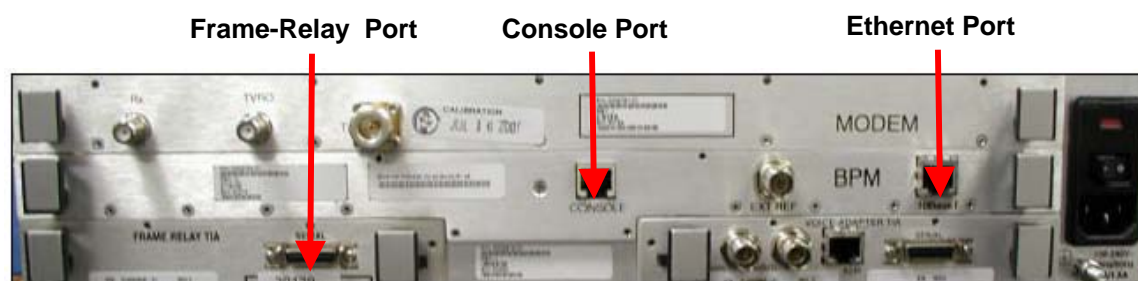

The Linkway 2100 has the following ports in the back of the unit:

- Frame-relay - Connects to the V.35 H port in slot 1 of the Memotec 960e and is called the main link.
- Ethernet - Used by AGS staff for remote M&C (Monitor and Control) of the Linkway modem.
- Console - Used for local configuration files known as bootfiles and for local access to the 2100 modem by MEVA II field technicians.

The Linkway 2100 has the following LEDs in the front of the unit:

- Power
- SAT (Satellite)
- I/O 1
- I/O 2



Linkway 2100

During normal operations the power, SAT, and I/O 1 are light green.

The Linkway Network

Linkway is a multi-carrier, multi-rate, TDMA (Time Division Multiple Access), VSAT platform that works with conventional satellites. It provides seamless full-mesh connectivity for flexible, on-demand broadband corporate networking applications. The Linkway system can support thousands of low-cost terminals with small antennas. Single-hop connectivity is a standard feature without the need for an expensive central hub station. Linkway 2100 is more cost-effective for remote VSAT applications. This terminal uses an L-band interface in support of broadband applications that span multiple satellite transponders.

The Linkway system automatically allocates satellite bandwidth on a call-by-call basis, based on dynamically measured traffic levels or on a fixed-assignment basis, if required. In addition to efficient TDMA and automated bandwidth-on-demand (BoD), Linkway eliminates the need for additional third-party networking equipment. This results in improved overall network reliability, lowered costs, and simplified integration with terrestrial networks.

The Linkway platform provides a unique architecture that supports the MEVA II star topology. Linkway's flexibility allows individual VSAT locations to be configured as very low-cost remote terminals and economical high-capacity gateways. Linkway broadband VSATs support multiple antenna and RF transceiver configurations with flexible carrier parameters that include variable bit-rates, power levels, and FEC (Forward Error Correction) settings for each carrier.

The Linkway 2100 contains the satellite modem and the necessary interfaces to provide Frame Relay or IP access. The Linkway terminals are housed in compact rack-mountable packages with L-band IFL to IBUCs operating in C-band. The modulator output and demodulator input can be set as indicated in the following table.

	Modulator Output	Demodulator Input
LINKWAY 2100 and LINKWAY.IP	0 to -30 dBm in ½ dBm steps	-35 to -75 dBm

Linkway Modulator and Demodulator

To optimize performance, Linkway performs automatic coarse setting of the internal front-end attenuator. Based on the satellite system and geographic location, the Linkway terminal can be deployed with a variety of IBUCs, ranging from 1.2-m/2-Watt Ku-band units to 3.8-m/60-Watt C-band units.

The Linkway contains a TDMA burst modem, TDMA frame controller, and terrestrial traffic interfaces. The MEVA II interfaces with the Linkway 2100 unit, is the built-in IP (Internet Protocol) and Frame Relay.

Basic Components of a Linkway Network

A Linkway network has the following basic parts:

- Traffic terminal - The Linkway 2100 is configured as a traffic terminal. The traffic terminals carry all communication traffic, including voice and data.
- The NCC (Network Control Center), a Sun workstation that provides the management and control functions for all NMS (Network Management System) servers. The NMS is the graphical user interface which is accessed using a standard web browser. The operator uses the web browser to configure the network and to request information from the NCC. The system supports NCC redundancy to increase network reliability.
- MRT (Master Reference Terminal) - The Linkway 2100 unit is configured to be the MRT, which controls timing and resource allocation of the MEVA II network. The MRT is located at the Miami hub along with the NCC (Network Control Center).
- AMRT (Alternate Master Reference Terminal) - The redundant AMRT is located in Woodbine, MD. This terminal serves as the backup for the MRT in the event that the MRT goes down.



Note: The **MEVA II Network Synchronization Diagram** on page 47 shows the basic components of a Linkway Network (except for the ART).

Linkway Modem

Linkway uses a multi-carrier, multirate, TDMA (Time Division Multiple Access) modem. Each carrier in the Linkway network can be configured with different speeds and FEC (Forward Error Correction) rates. Larger carriers increase terminal throughput, but also increase ODU power and size requirements. Smaller carriers limit connectivity the star topology. With the exception of the ODU size, the system administrator can modify the configuration at any time. As many as 256 carriers can be supported in a Linkway network. Initially, however, only one carrier is required for each network. Additional carriers can be added as the network traffic increases. All carriers in a transponder can be automatically shared among the users on demand. Assignment of terminals to carriers is performed dynamically by the NCC collocated with one terminal.

The Linkway 2100 supports five modem symbol rates:

- 312 ksps
- 625 ksps
- 1.25 Msps
- 2.5 Msps
- 5 Msps

This multi-rate feature accommodates various network applications and antenna sizes. Regardless of the selected modulation and coding scheme, carrier bandwidth occupancy remains constant. Modulation and coding selection affect power requirements, as well as user information throughput. Therefore, it is common to configure the traffic bursts with QPSK (Quadrature Phase Shift Keying) modulation to increase user information throughput. The NCC automatically configures modulation and coding for each burst. The transmit and receive side of the modem can operate and hop asymmetrically and independently.

The Linkway NCC

The NCC (Network Control Center) is the brain of the MEVA II network. It performs overall management and control of the Linkway network. Network configuration is defined at the NCC and automatically distributed to the terminals. The NCC can be configured in a redundant or non-redundant architecture, either at the same site or at geographically separated sites.

A single Linkway traffic terminal is always designated as the MRT and connected to the NCC using a 10BaseT Ethernet interface. The NCC then communicates other Linkway terminals through the MRT via the satellite link. The system does not require a dedicated terminal for NCC connection or reference terminal purposes, and the MRT also carries user traffic. Operators located remotely can log on to the NCC using PCs (or Macs) with web browsers. This remote client (NMS - Network management System) is the operator's interface to the network configuration and status screens. The NCC is hosted on a Sun workstation. The following figure illustrates a redundant NCC setup. A non-redundant situation uses a single Sun workstation, external modem, and universal power supply.

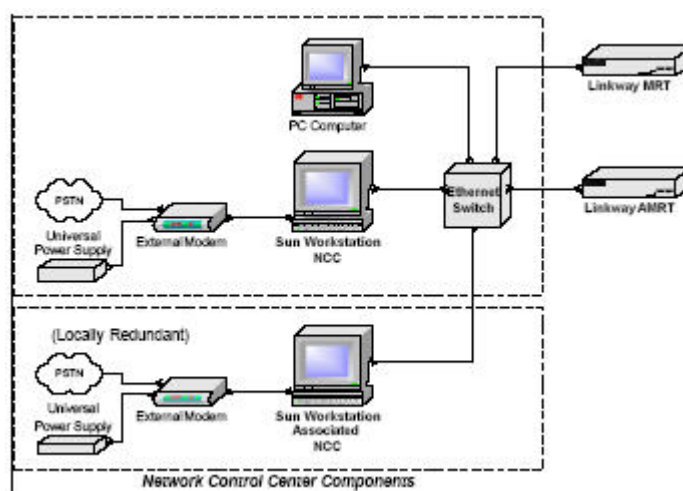

Redundant NCC Elements



Note: See *Network Management* on page 72 for more information about the NCC.

AST 3100

The AST 3100 is an M&C device that gathers information about the MEVA II site and reports the information back to AGS by SNMP (Simple Network Management Protocol) Traps. The Unit is equipped with a remote dial phone that when connected to a telephone line allows AGS staff to remotely solve problems during a satellite link outage.

LIEBERT UPS

The Liebert UPS provides power to the MEVA II equipment during temporary power disruptions. It also filters and conditions power to a 120 VAC RMS. The UPS is in the MEVA II remote site rack in addition to any other UPS provided by the site.

CISCO ETHERNET SWITCH

All MEVA II remote rack equipment with an Ethernet port is inter-connected by the Cisco Ethernet switch. AGS staff can access all equipment connected to the switch remotely over the satellite link. The Cisco Ethernet switch is configured with port security that prevents unauthorized access into the AGS M&C network.

Network Operation

MEVA II establishes communication through the Linkway 2100 modem, which is configured as an AMRT (Alternate Master Reference Terminal), MRT, and traffic terminal. All configurations are done on the NCC and downloaded to the Linkway 2100. The AMRT, which is located in Woodbine, MD, improves network reliability.

How COMMUNICATION IS ESTABLISHED OVER THE LINKWAY

The NCC controls acquisition and synchronization of the Linkway network. Upon startup, the following occurs:



1. The NCC establishes contact with the MRT and commands it to initiate reference station acquisition and synchronization.
2. The reference station starts transmitting the reference burst. In “loopbackbeam” operation, the reference station hears its own transmission in order to achieve synchronization.
3. After the MRT achieves synchronization, the NCC initiates the acquisition and synchronization procedures for traffic terminals in the system, using the reference terminals as a relay to communicate with the terminals.
4. Traffic terminals are commanded to transmit a sequence of acquisition bursts, whose arrival time and frequency are measured by the MRT.
5. Using these measurements, the NCC sends back frequency and timing corrections to the traffic terminals, and they are then ready to carry user traffic.

After initial acquisition and synchronization, traffic terminals periodically transmit control bursts, whose timing and frequency are measured by the MRT. Using these measurements, the NCC sends back further frequency and timing corrections to the terminals. These corrections keep the terminals synchronized with satellite movements.

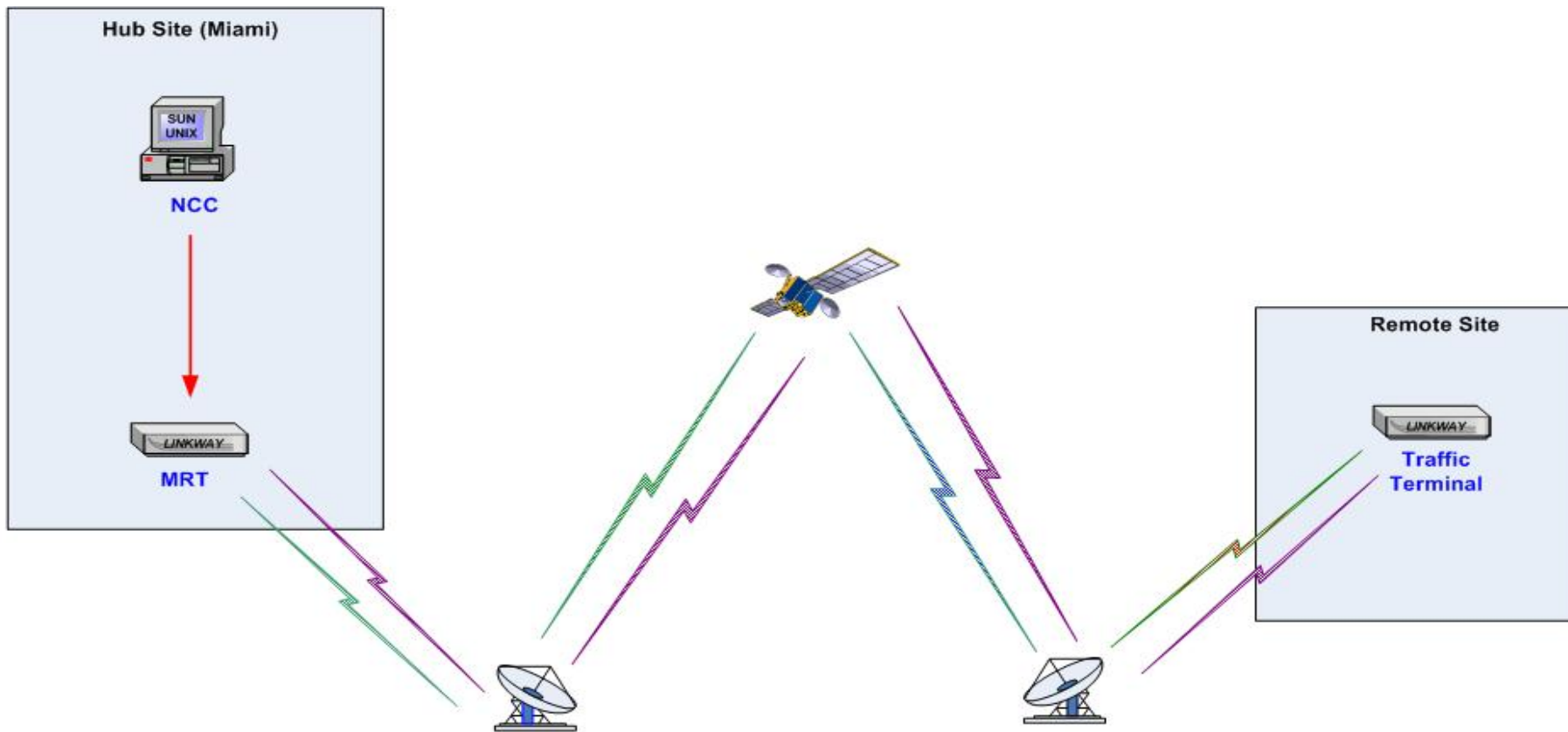
MEVA II NETWORK SYNCHRONIZATION DIAGRAM



LEGEND

	Transmit Acquisition and Reference Burst
	Receive Acquisition Burst

TRAFFIC BURSTS DIAGRAM

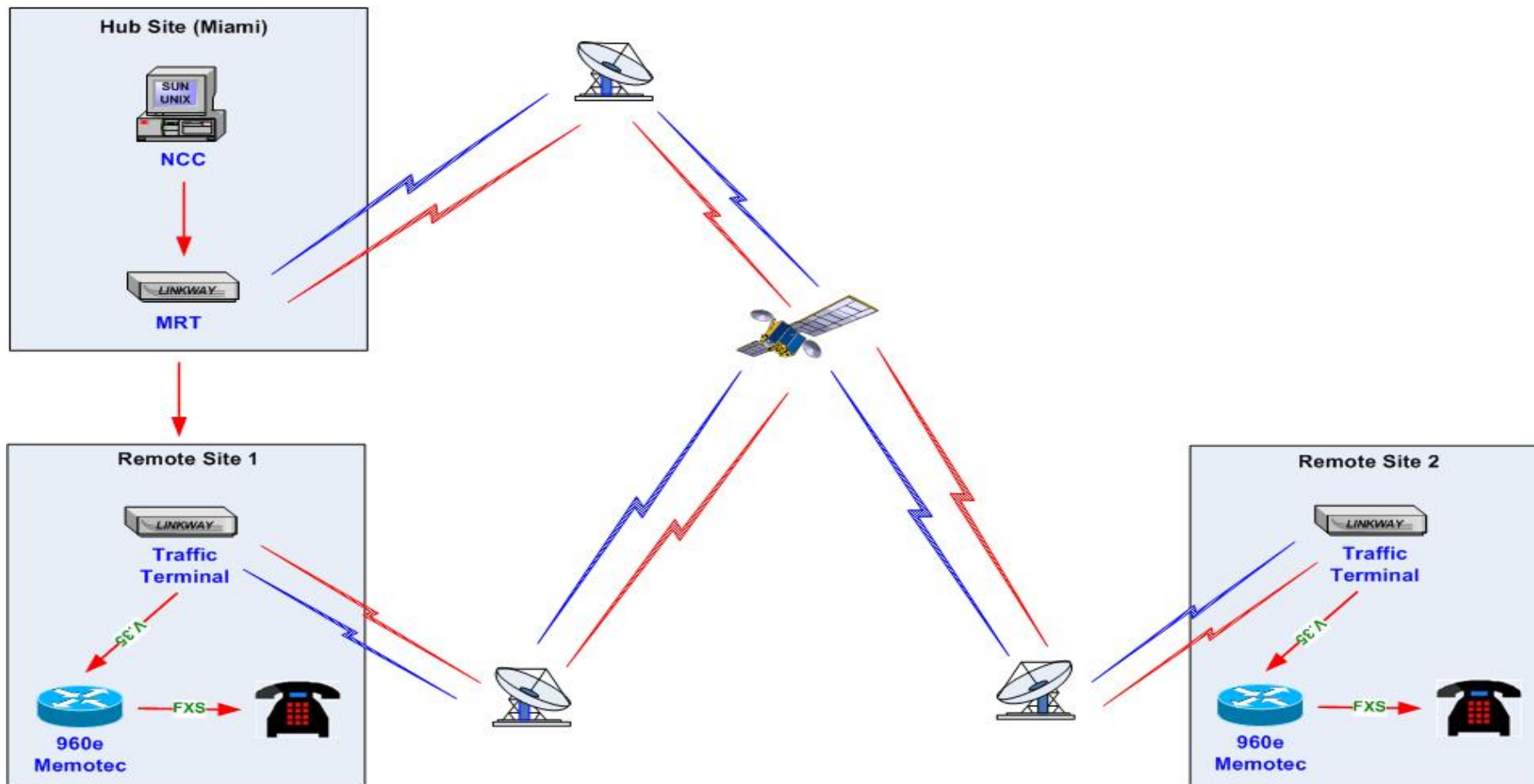

LEGEND



BURST TYPES

The following graphics show bursts from the NCC point of view. (Spectrum analyzer views will differ.) The figure below shows traffic in idle status.

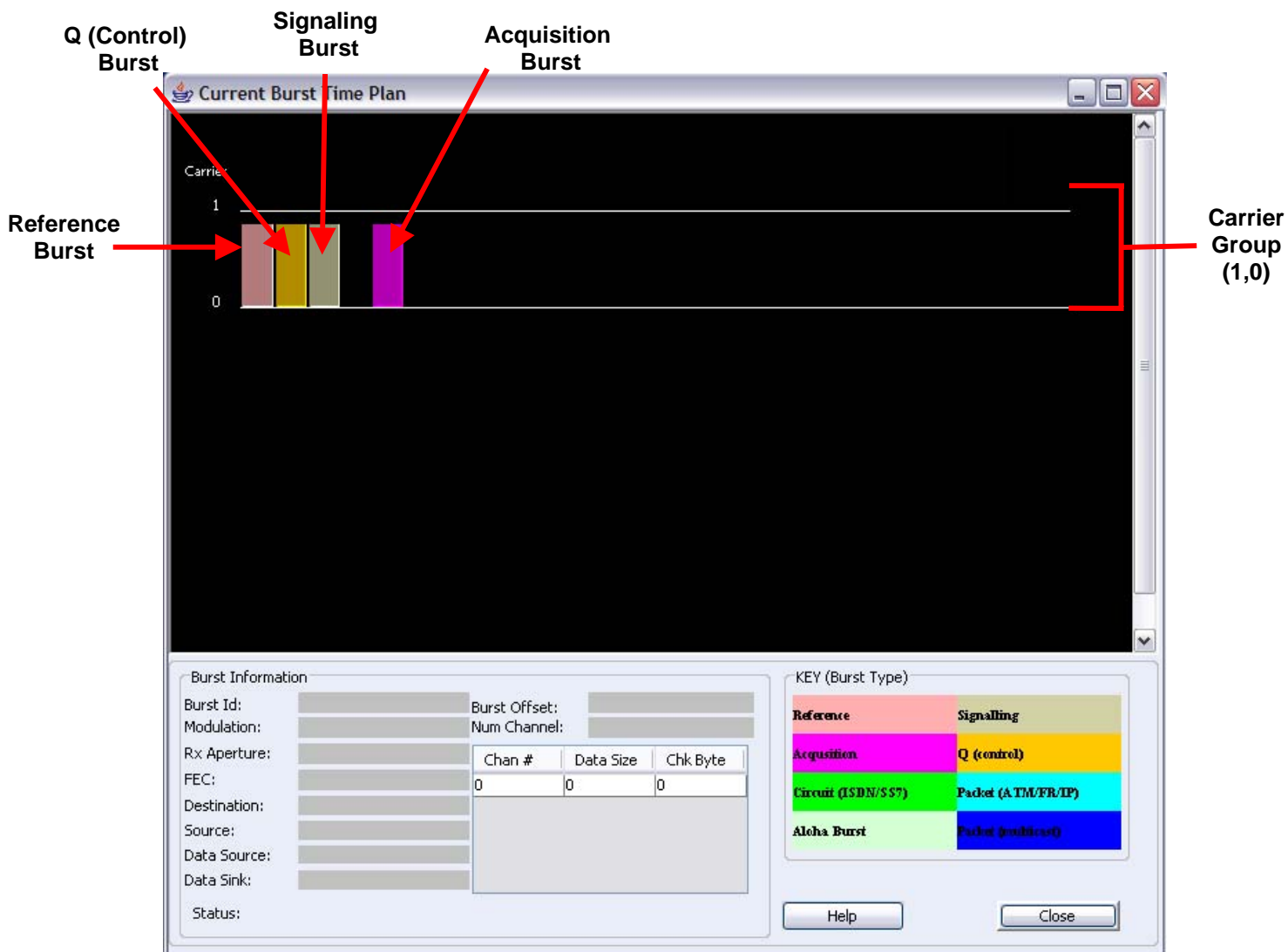

Idle Traffic

Packet Bursts

The following figure shows a packet (traffic) burst. All packet bursts (voice and data) display as two blue bars. The spacing between the two bars may vary and may be located on any carrier. All other burst types (acquisition, signaling, etc.) are always located on the beginning of carrier 0 (during both idle traffic and packet bursts).

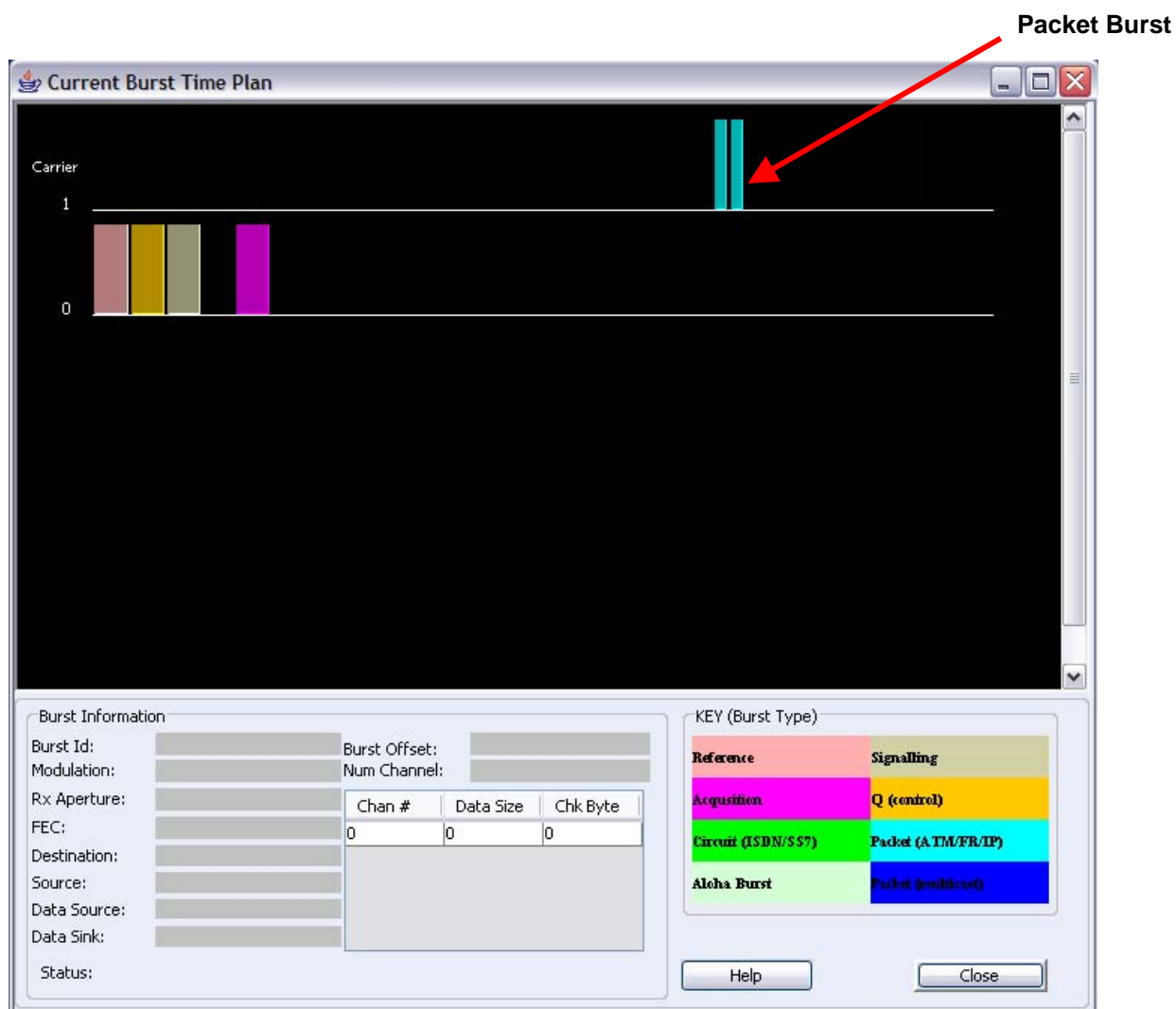

Packet (Traffic) Burst

The following sections describe burst types in more detail.

LINKWAY TDMA ARCHITECTURE

TDMA (Time Division Multiple Access) works by dividing a radio frequency into time slots and then allocating slots to multiple calls. In this way, a single frequency can support multiple, simultaneous data channels. TDMA consists of the following features:

- Frame Format and Hierarchy
- Site and Terminal Addressing
- Acquisition and Synchronization
- Clock Management
- Packet and Circuit Transport Services

Frame Format and Hierarchy

Linkway employs a hierarchical frame structure composed of frames, multiframes, and control frames as illustrated in the following figure.

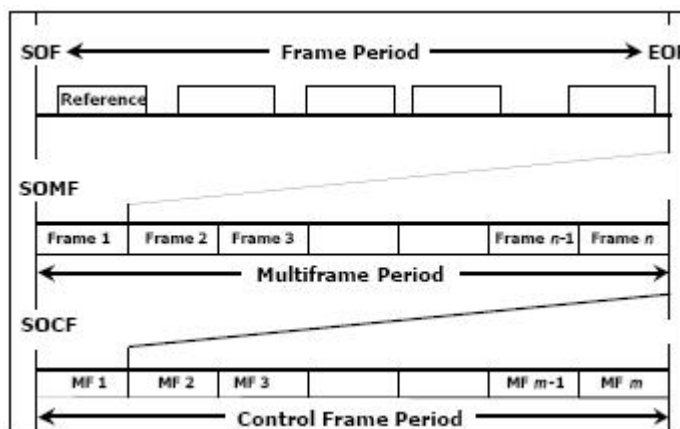

TDMA Frame Hierarchy

TDMA Frame Structure

A TDMA frame is the basic periodic interval of time during which a terminal transmits or receives one or more bursts. Linkway frame duration has a nominal value of 27 ms (milliseconds). Every frame boundary is represented by an SOF (Start-of-Frame) instant. The SOF is a point that represents the beginning of the first symbol of a reference burst in a frame. Each reference burst frame is identified numerically by a frame identifier.

As the following figure illustrates, each carrier in a multicarrier operation transports a TDMA frame that is time aligned with all other carriers' frames on SOF, SOMF (Start of Multiframe), and SOCF (Start of Control Frame). A multiframe is the duration of N consecutive frames. The nominal value for N is 8. Multiframe boundaries are represented by an SOMF instant encoded in the frame identifier.

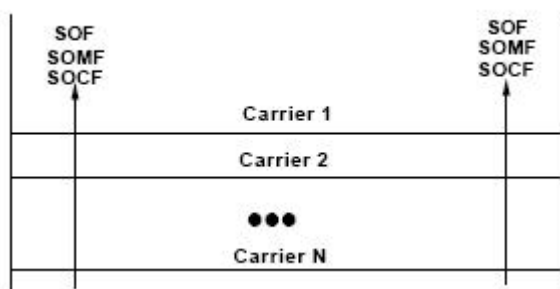

Multi-Frame TDMA Frame Alignment

Linkway transmits and receives bursts on specified frames of the multiframe. A control frame is the duration of M consecutive frames. The nominal value for M is 128. Control frame boundaries are delineated by an SOCF instant encoded in the frame identifier. Linkway transmits and receives bursts on specified frames of the control frame.

TDMA Burst Structure

In Linkway, the burst is the high-level unit of transmission, with multiple burst types providing efficient space-segment use. The following table describes the burst types.

Burst Type	Transmitting Terminal Type	Purpose
Reference Burst	Reference	<ul style="list-style-type: none"> Conveys outbound NCC signaling Conveys timing feedback to traffic terminals Establishes receive timing
Signaling Burst	Traffic	<ul style="list-style-type: none"> Conveys inbound traffic terminal signaling
Acquisition Burst	Traffic	<ul style="list-style-type: none"> Conveys transmit response message Used to acquire traffic terminal transmit timing
Control Burst	Traffic	<ul style="list-style-type: none"> Conveys traffic terminal status report Used to acquire traffic terminal transmit timing
Traffic Burst	Reference and Traffic	<ul style="list-style-type: none"> Conveys circuit and packet data

Linkway Burst Types

Bursts are composed of several fields. The following diagram displays the burst structure and its relationship to frames and carriers.

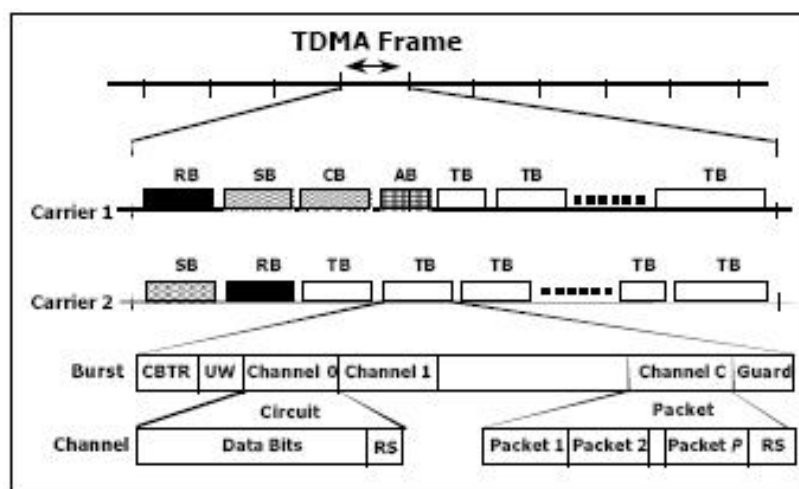

TDMA Burst Structure



Note: The TDMA Burst Structure diagram depicts the channel structure for illustrative purposes only. The Circuit and Packet data are never on the same burst.

The burst structure has the following elements:

- **CBTR (Carrier and Bit Timing Recovery)** - This data pattern aids receiving modems in obtaining carrier and symbol clock acquisition. The CBTR consists of 128 consecutive symbols of alternating binary 1's and 0's. The CBTR beginning defines the burst position in the frame.
- **UW (Unique Word)** - This data pattern aids receiving modems in locating the first symbol of the first channel in the data field. The UW consists of 48 consecutive symbols. Reference bursts have a UW that differs from non-reference bursts.
- **Channel structure** - Bursts can carry either 64-kbps circuit or packet data within their channels. Packet bursts may have up to 8 channels. Circuit bursts are either 64- kbps data or 8-kbps compressed voice. Circuit-data channels are simply filled with encoded data. Packet-data channels contain many packets of varying length. To facilitate error detection and depending on correction, Reed-Solomon check bytes are included in both circuit and packet data channels.
- **Guard time** - Every burst is defined in the frame with guard space to prevent transmit burst timing errors from resulting in burst overlap and loss of data. Each terminal's bursts are controlled in order to limit timing variations at the satellite to $\pm 1/2$ guard time.

Single-Beam and Multiple-Beam Operation

Linkway is designed for both single-beam and multiple-beam operation. The following figure shows a simple example of each. As shown in the figure, in the single-beam case, all terminals have transmit and receive access to all carriers assigned to the system. The MRT directly supports all terminals. In the multiple-beam case, terminals have transmit access to one set of carriers and receive access to another. The MRT supports terminals in Beam 2 and the SRT (Supporting Reference Terminal) supports traffic terminals in Beam 1.

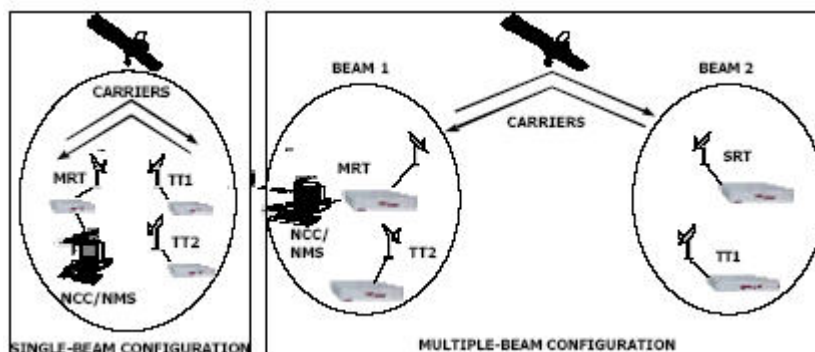

Single and Multiple Beam Configurations

Site and Terminal Addressing

The Linkway site and terminal addressing scheme efficiently accommodates a wide range of network configurations and is designed to support thousands of sites. Each site can have multiple terminals. In addition to individual terminals, the system can also address sites and groups of sites. This addressing scheme provides for very large networks without penalizing small ones.

Although only one terminal will be designated as the MRT in a Linkway network, each Linkway terminal can perform as both a reference and traffic terminal. The NCC dynamically assigns the reference terminal function, which simplifies configuration, maintenance, and upgrade procedures, while increasing the system's flexibility.

Acquisition and Synchronization

Because the Doppler motion of the satellite and oscillator drift normally cause timing variations, maintaining synchronization is critical to the error-free operation of any network. Linkway terminals use TDMA acquisition and synchronization procedures to establish and maintain burst synchronization.

Linkway procedures enable new terminals to join the network quickly. Typically, a terminal will enter the network within 30 seconds of power up. A network of 100 terminals ready to enter the network typically completes entry within 10 minutes. As the network grows, or if faster entry is desired, multiple acquisition bursts can be defined. Terminals can enter the network at approximately the rate of 10 per minute per acquisition burst.

Clock Management

To minimize timing error in the system, each Linkway terminal automatically monitors and adjusts its DDS (Direct Digital Synthesizer) to match that of its MRT or supporting reference terminal.

To further minimize timing error, an industry standard, a highly accurate external clock source can be connected to the reference terminal as an option. The reference terminal's DDS tracks the external clock in frequency and phase, while all other terminals continue to track the reference terminal's DDS. This is a cost-effective method for highly accurate timing throughout the system. Without an external clock source, the DDS is accurate to 1 part in 10. An accurate external clock typically raises accuracy to 1 part in 10.

Linkway TDMA networks operate with combinations of terminals functioning in timing modes that contain multiple clock sources and packet interfaces. Linkway terminal interfaces *accept* data timed to the terrestrial data-receive clock and use the terrestrial data-receive clock in *transmitting* data to the terrestrial network.

In order to generate accurate clocks in its distributed TDMA system, Linkway uses a distributed algorithm that requires an accurate clock source at the TDMA terminal. (See the following figure.) The local clocks of all other terminals are phase locked to the reference terminal's clock.

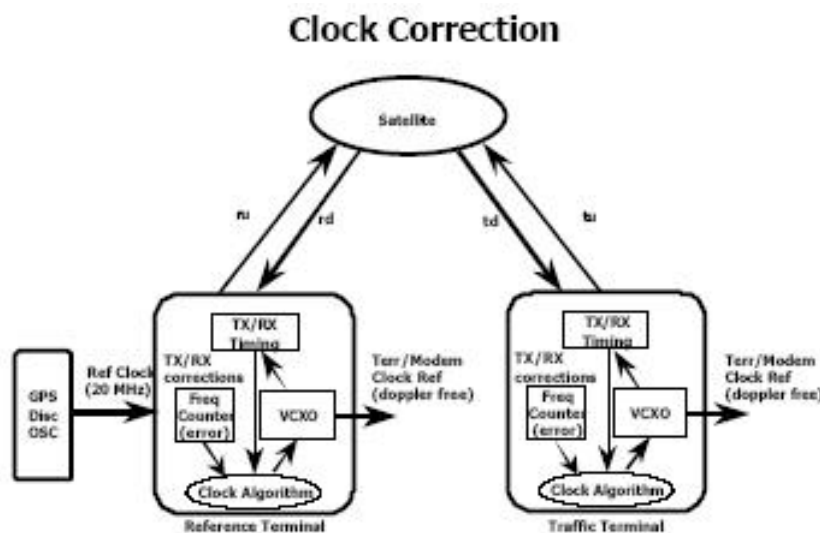

Clock-Generation Algorithm

Packet and Transport Services

Linkway provides flexible packet- and circuit-channel access to the space segment. The wide variety of data rates and packet sizes are supported by Linkway, enabling the system to carry many kinds of traffic efficiently. The following table summarizes the data rates and packet sizes.

	Data Type	
	Circuit	Packet
Minimum Rate	8 kbps	0 kbps
Maximum Rate	1.875 Mbps	4 Mbps (duplex)
Minimum Packet Size	N/A	3 Bytes
Maximum Packet Size	N/A	1518 Bytes
Examples	ISDN	IP, ATM, and Frame Relay

Data Rates and Packet Sizes

LINKWAY PROTOCOLS AND SERVICES

MEVA II uses the built-in IP (Internet Protocol), and the Frame Relay interface protocol.

IP Service

The Linkway system supports IP networking using an RJ-45 10BaseT Ethernet LAN port as the physical interface. Internet protocols are the means by which a router gains information about the network.

Routers determine the best path or route to get to the destination. The purpose of a router is to supply efficient traffic flow and management of end-to-end packet flow. For IP, a Linkway terminal acts as a network router and routes each IP packet toward its destination. As a router, Linkway broadcasts advertisement packets (signifying its presence) to all network nodes and communicates with the other routers regarding their network connections, the cost of connections, and traffic load levels.

The Linkway network supports most of the standard routing protocols, including the Routing Information Protocol, both RIP-1 and RIP-2. Linkway uses dynamic routing, which automatically reconfigures the routing table. Unlike a typical IP network, which supports only best-effort service, Linkway also allows configuring minimum-guaranteed-packet throughput between two sites. Linkway also supports multicast routing, where a source terminal can send a single transmission to multiple terminals at the same time.

Convergence (reconfiguring the routing tables) must occur quickly before traffic terminals with incorrect information misroute data packets into dead ends. To solve this, the Linkway MRT acts as an integrated router and exchanges information about the network's topology with all traffic terminals in the network. Using its bandwidth-on-demand function, the MRT also continually re-balances the traffic load and regularly updates a map of the entire network, including all the devices operating at or below its own protocol level. Using this network map, the MRT ascertains the current status of all possible paths to destinations and selects the best method—usually the fastest—of transporting the packet.

RIP (Routing Information Protocol)

Because of the popularity of TCP/IP throughout the world in today's networks, many vendors' products have RIP implementations. Linkway, which supports RIP-1 and RIP-2, can handle nearly all of these implementations. For example, The major features of RIP include:

- Using the user datagram protocol for broadcasting routing tables.
- Using a count of each router or gateway the packet needs to pass through—called a hop count—to measure the distance between source and destination. The maximum number of hops allowed is 15. A network is considered unreachable if it has 16 or more hops.
- Updates to routing tables are sent by routers every 30 seconds.
- Routes are timed out in 180 seconds unless an update for that path has arrived.

RIP operates with two types of user devices: active and passive. Active users advertise their routes via a broadcast over their networks, while passive users listen and update their routes based on the RIP information, but do not advertise routes.

An active RIP user—such as Linkway—advertises routes about every 30 seconds. Within a RIP broadcast is a paired listing of every IP network the sender of the RIP message can reach and the distance, in hops, to that network. Within RIP, a router is defined to be one hop away from directly connected networks, two hops from networks that are reachable from one other router, and so on.

The RIP mechanism in Linkway is implemented on the local Ethernet interface of a Linkway terminal whereby route updates are transmitted locally to the LAN or to a directly connected router. Learned routes updates from a Linkway terminal will also propagate to other Linkway terminals which have an active PVC established between them and are enabled with RIP. The RIP route updates are transmitted via the Linkway's Control Channels.

These frequent route updates of RIP would create a significant traffic load and hence a wasteful use of expensive satellite bandwidth for conventional technologies. Linkway includes a unique bandwidth saving scheme whereby only changes to the route table are transmitted via Satellite. Additionally, these route updates are sent using the Linkway control channels without the IP and UDP headers of typical RIP messages. In this manner, all RIP routes are continuously updated but in a very bandwidth efficient manner.

IP Service Provisioning

To provisioning IP service, refer to the following steps:

1. Submit the Linkway terminal IP address, subnet mask, and the routing protocol (RIP1 or RIP2) to the NMS.
2. Define any permanent virtual circuits and related CIR values to be used within the network. The NMS automatically downloads the configuration to the NCC, which sends it to all relevant terminals, and the Linkway system is ready for IP traffic.

IP Service Operations

IP Service Operations involves the following procedures:

1. The traffic terminal coordinates with the NCC via a connection defined between the MRT and the traffic terminal.
2. When a traffic requirement exists, the traffic terminal sends a connection request to the NCC.
3. The NCC checks both sending and receiving terminals to verify they are active (UP on the network). It also checks the IP interfaces to verify they are active. Any defined CIR for the connection will be used first for sending the transmission.
4. The NCC allocates additional bandwidth on an as-available basis, using bandwidth-on-demand algorithms should more bandwidth be required.

Multicast traffic uses the same process as unicast (single point-to-point transmission), with the multicast connection defining which terminals will receive the transmission. The NCC allocates bandwidth-on-demand to the multicast transmission, giving network priority to multicast traffic over unicast. Receiving terminals accept the transmission only if a client has requested it. Both features ensure efficient bandwidth use in the Linkway network.

Frame Relay Service

MEVA II uses Linkway's Frame Relay service to connect to the Memotec CX960e. Linkway's Frame Relay access is supported at the UNI/NNI connection level with ANSI or ITU LMI (Link Management Interface) for access management and is compliant with ITU and ANSI standards.

A serial synchronous port is the physical layer interface, using V.35 connectors with DTE or DCE options and internal or external clock rates up to 2 Mbps. Linkway performs frame switching and forwarding on a DLC (Data Link Connection Identifier) basis. Multiple connections (DLCs) can be provisioned to multiple destinations. Each connection is configured with bi-directional CIR (Committed Information Rate), committed Bc (burst size), and Be (excess burst size) as QoS (Quality of Service) parameters. These are soft configurable on a per-virtual circuit basis, which allows the operator to tailor the virtual circuit to requirements:

- Fixed-based CIR virtual circuits can be provisioned with finite CIR, matching Bc, and zero Be. The entire bandwidth is preallocated before the virtual circuit is activated. This type of virtual circuit is more suitable for constant bit rate real-time traffic like voice and leased-line applications.
- Usage-based CIR can be provisioned by reserving part of the bandwidth as CIR and allocating the rest on demand using nonzero Bc. This type of virtual circuit is suitable for real-time variable rate applications like video conferencing or video streaming.
- Zero CIR virtual circuit is intended for non time-critical e-mail, file transfer, and applications like web-browsing. With this service there is no guarantee of sustained bandwidth as the system does not preallocate any bandwidth. Bandwidth gets allocated as traffic increases. If the system has to drop traffic, this type of traffic is first to be discarded.
- Asymmetric CIR allows different CIRs to be provided in each direction of the virtual circuit. It is useful for applications such as file transfer that require more traffic going in one direction than the other. Frame Relay over Linkway gives users the cost savings of a shared service with the quality of service equal to a private line. Dynamic bandwidth management enhances the inherent advantage of Frame Relay's statistical multiplexing.

Frame Relay Service Provisioning

Provisioning Frame Relay service uses the NMS and involves the following procedures:

1. Configure the serial interface for Frame Relay service. Select the rate of transmission, clock source, and type of interface (V.35). Specify the LMI type - ANSI or ITU and other related parameters.
2. Configure the connection. Select both source and destination sites and interfaces, and other related QoS parameters (e.g., CIR and Bc). The NMS automatically downloads the configuration to the NCC, which sends it to all relevant terminals, and the Linkway system is ready for Frame Relay traffic.

Frame Relay Service Operation

Frame Relay Service Operation involves the following procedures:

1. The Linkway terminal helps establish the virtual circuit with the NCC. It waits for its local interface to be active before sending the connection request to the NCC. (*Active* means that LMI between the interface and the connected user equipment is up and running.)
2. The NCC waits for a connection request from both sides of the connection to arrive before bandwidth allocation. Bandwidth equivalent to the configured value of CIR is allocated and both terminals are informed of this resource allocation.
3. The concerned terminals report the virtual channel as *New* and *Active* at their LMI interface using connection signaling information elements.
4. Traffic on the connection begins. Incoming traffic is policed for the traffic agreement, with frames in excess of CIR tagged as non confirming frames. Each connection has its own queue of frames for transmission over the satellite interface.
5. Linkway employs its patented bandwidth-on-demand algorithms to allocate more bandwidth, when available, for transporting traffic in excess of CIR.
6. In the event an interface or terminal goes down, the connection at the other end is reported as inactive, and bandwidth is de-allocated.
7. When the interface recovers, the connection is re-established.

Troubleshooting Concepts

The steps a technician takes when troubleshooting the MEVA II system should be performed in a logical manner, and should fit the symptoms indicated. The following sections provide concepts that will guide technicians in their troubleshooting approach. A list of common problems is provided, and how to identify and resolve each problem.

Initially Reporting a Problem

When a user reports a problem, the user typically does not provide enough detail. As a result, the technician cannot determine the exact problem. For example, a user may report that a phone line is dead. The technician needs to ask very specific questions in order to get to the root of the problem. In this case, the technician should ask the following:

1. What extension are you calling from?
2. Who are you trying to call? Their extension?
3. When you pick up the phone, do you hear dial tone?
4. When you call, does it not ring? Fast busy? Slow busy? No answer?
5. Can you call another site from the same extension?
6. Are other extensions having the same problem?

Questions like these can provide the technician with a good starting point in fault isolation and resolution.

Documenting a Problem

Before taking any actions, it is vital to report all MEVA II-related issues to the AGS TOC (Technical Operations Center), other than initial problems like the ones described above. The TOC always asks the same questions so they can log and issue a trouble ticket number. This prevents the technician from working on a problem unnecessarily. For example, Site A might report that they are getting a fast busy signal when dialing Site B's extension (1234) from their extension (5678). The TOC received a call 15 minutes earlier from Site B that they were having a problem with extension 1234. The technician now knows that the problem exists in another location. Therefore, the technician can perform a confidence check with the TOC or another site using the 5678 extension.

If a problem does exist at Site A, the TOC can aid in isolating the problem to the LRU (Line Replaceable Unit). It is important for the site technician to keep the TOC informed of further steps to take to isolate and resolve the problem. This enables the TOC to document the actions taken, so that fault isolation and resolution time is reduced for sites with similar symptoms in the future.

Fault Isolation

Problems related to MEVA II system operations at a remote site can be isolated to the following areas:

- Satellite Link - This area can be divided into the following:
 - RF Components - Antenna, Feed, BUC and power supply, LNB
 - IFL (Inter Facility Link) - Transmit and Receive cables, power for BUC
 - Satellite Modem (Linkway 2100)
 - Local interference - Transmitting devices can cause in-band (same frequency range) or out-of-band interference
 - Weather
- Frame Relay Device (Memotec 960e) - This includes all voice and data circuits
- Customer Premise Equipment - This includes any equipment down line from the MEVA II system, such as the ICON card and server for AFTN circuits, a facility phone switch, handsets, and headsets, etc.
- Facility Power - The power source of the entire MEVA II system. While a power outage is easily identified, fluctuations in power levels causing component issues or failures may be difficult to trace.

Once you have the problem classified into one distinct area, you can begin to isolate components. Using the symptoms provided, a technician can classify which area the problem belongs to and eliminate areas to check. For example, if one phone line is dead, but other lines and data are all working fine, then the satellite area can be eliminated as the root cause. This eliminates over half of the MEVA II components. The key is to classify and eliminate without making assumptions. If another site reported a problem with the line you were having trouble with, you should perform a confidence check on your line with another site or the TOC to ensure yours is fully operational.

It is important not to eliminate cabling as a potential problem. Cabling that is permanently installed, tested, and has had traffic running for some time rarely has problems. However, problems may occur, such as damage to the cable due to another installation, or someone bumping or damaging a connector.

Problem Resolution

Once the cause of the problem has been identified, the technician must report the following to the AGS TOC prior to taking actions:

- Make, model, and serial # of the faulty component
- Make, model, and serial # of the replacement component (when known)

The TOC will take action to have a RMA (Return Material Authorization) number assigned. (Refer to ***RMA and Shipping*** on page 71).

Common Problems List

The following table lists common problems related to MEVA II, their causes, and their resolutions. The first step in all of these scenarios is to contact the TOC, report, and take the basic actions necessary.

Symptoms	Possible Causes	Steps to Isolate and Resolve
AFTN Circuit Not Passing Data	ICON card or server needs to be reset (not part of MEVA II)	Contact TOC and have them conference in NADIN in Atlanta. NADIN can analyze to see if the problem is with the end equipment or the path. The TOC can also check the MEVA II path to see if packets are flowing in both directions.
	Issue with path at remote site (may or may not be part of MEVA II)	Insert RS232 looping plug on end of V.35 H cable (disconnect from ICON server). If NADIN can see the loop, then the path through the remote site MEVA II equipment is good.
	Issue with path up to and including MEVA II equipment in Miami	If NADIN cannot see the loop at the remote site (see above) the TOC can isolate the problem by having the FAA in Miami insert a loop toward the remote site at the Memotec. If the remote site can see the loop, then the MEVA II equipment is working properly. The TOC can then have the FAA in Miami and NADIN in Atlanta isolate the problem. If the remote site cannot see the loop, then the TOC isolates the problem to the data card or wiring at Miami or the remote site.
Voice Shout Down Audio Distorted or Low	<ul style="list-style-type: none"> *Problems with end equipment (headsets, site facility phone switch if the circuits routes through it, etc) *Faulty Memotec card (either end) *Memotec needs reset *Problems with wiring 	<p>Once the end equipment is eliminated (handsets, headsets, phone switches, etc.), the TOC can coordinate with the site to reset the Memotec card. This should only be done under close coordination as all site circuits will go down as the Memotec is being reset.</p> <p>To prove out the circuit, the two sites involved can set up a TIMS set at each end and run tone testing.</p>
Switched Voice Problem	<ul style="list-style-type: none"> *Problems with end equipment (headsets, site facility phone switch if the circuits routes through it, etc) *Faulty Memotec card (either end) *Memotec needs reset *Problems with wiring 	<p>Once the end equipment is eliminated (handsets, headsets, phone switches, etc.), the TOC can coordinate with the site to reset the Memotec card. This should only be done under close coordination as all site circuits will go down as the Memotec is being reset. This is also the case if a Memotec card must be replaced.</p>

Symptoms	Possible Causes	Steps to Isolate and Resolve
Satellite Link	<ul style="list-style-type: none">*Inclement weather*Failed BUC or PS*Failed LNB*Antenna Issue (re-point, etc)*Feed Issue*Cabling issue*Interference	<p>Check weather conditions at affected site and Miami (reference burst).</p> <p>Isolate between the TX chain, the RX Chain, and the modem.</p> <p>Contact the TOC to check the links between the affected site and the sites they connect to.</p> <p>Check for power indication on BUC.</p> <p>Reset Linkway.</p>

*See *Interference Testing* on page 89.

Preventive and Corrective Maintenance

The following corrective and preventive measures should be taken to address MEVA II issues:

- Reporting an Outage
- Scheduling Downtime for Maintenance
- RMA and Shipping
- Network Management

Reporting an Outage

Whenever an outage occurs, the affected site must contact the AGS TOC (Technical Operations Center) using one of the following contact methods:

866-244-5012
410-970-7700
MEVA II ext 2400
nmcsupport@ses-americom.com

This allows the TOC to work with the site to isolate the problem, ensures proper documentation, and the resolution. The TOC will go through the basic troubleshooting process, eliminating problems at each level, and step toward problem isolation that would point to a specific cause. The site technician will carry out actions requested by the TOC to isolate the problem and will perform the actions necessary to correct the problem.

When contacting the TOC, the site must provide the following information:

- Where the site is calling from
- Who the site point of contact is (phone, mobile, and e-mail)
- Who the site is trying to contact (switched voice especially – include circuit and / or extension numbers)
- What is the specific nature of the problem (satellite link down, fast busy on one switched voice line, AFTN traffic being received, but not transmitted – This information should include applicable circuit and / or extension numbers). Provide as much detail as possible
- When did the site start experiencing the problem
- Current weather conditions

The TOC will issue a trouble ticket number that should be referenced any time a site calls in for status or updates.



Scheduling Downtime for Maintenance

The following procedures must be used when scheduling preventive maintenance that requires down time, or in the event of a corrective maintenance where the satellite link is currently up but has to be brought down to correct the problem (intermittent LNB, etc.).

1. The site technician must fill out and submit the SES AMERICOM form - Maintenance Method of Procedure (MOP) to the following e-mail address:
nmc@ses-amicom.com



Note: See the following section for an example of the MOP form.

2. The TOC (Technical Operations Center) will issue start and completion notices to all concerned parties to include:
 - Personnel designated by the site performing maintenance
 - Applicable AGS personnel
 - The FAA SOC in Miami, FL
3. The TOC must fax an outage request to the FAA SOC in Miami to:
305-716-1293 (fax)
305-716-1203 (phone)

This fax must list all affected MEVA II circuits for the site, as well as outage times and TOC contact information.
4. Once the site has completed the required maintenance and restored service, the site technician must contact the TOC and report completion. The TOC will then issue completion notifications.

EXAMPLE OF THE MOP FORM

The following MOP form is for a MEVA II Jamaica outage request to the TOC.

Maintenance Method of Procedure

I. Requestor Information

Name and Title:	Department/Office	Office Phone/Cellular
Matthew Toney - Program Mgr	AGS	301-797-5042 / 717-977-5867

II. Work Description

Work Start Date/Time:	8/1/07 02:00 GMT
Work End Date/Time:	8/1/07 04:00 GMT
Maintenance back up date:	
Maintenance Ticket:	
Project Name:	MEVA II
Type of Work:	Annual Maintenance
Affected Equipment:	MEVA II Jamaica Site

III. Work Done By

Name and Title:	Department/Office	Office Phone/Cellular
Keith Hildonen – Field Eng.	AGS	603-203-8609

IV. Additional Contacts

Name and Title:	Department/Office	Office Phone/Cellular
Ron Teske – Ops Mgr.	AGS	301-474-2332 / 410-382-3846
Matthew Toney – Program Mgr.	AGS	301-797-5042 / 717-977-5867
Rob Tate – Program Engineer	AGS	301-797-5093 / 301-693-0969

V. Customers

Customer Name	Phone Number	Emergency Phone
FAA Miami Center	305-716-1203	



VI. Information to identify the customers (antenna, satellite, transponders, contract number, etc.):

VII. Site Information (if available)

Affected Sites	Phone	Is Access Needed?
MEVA II Jamaica	876-978-4037	YES

VIII. Approval Signatures

Name and Title	Signature	Date
Matthew Toney – Program Mgr.		7/10/07

IX. Reference Material

Name	Use	Location

X. Objective

a.

XI. Precautions

XII. Procedures

Step #	Procedure	Check	Notes
1			
2			
3			
4			
5			
6			

RMA and Shipping

In the event that problem isolation measures indicate the need for a component repair or replacement, the site will perform the following procedures regarding RMA (Return Material Authorization) number assignments and shipping arrangements.

RMA NUMBER ASSIGNMENT

Refer to the following procedures to assign an RMA Number:

1. Once the site has removed the failed component, contact the AGS TOC (Technical Operations Center) using one of the following contact methods:
866-244-5012
410-970-7700
MEVA II ext 2400
nmcsupport@ses-americom.com
2. Provide the following information to the TOC:
 - The make, model number, and serial number of the failed component
 - The make, model number, and serial number of the spare component now on line
 - The symptom(s) of the failed component

The TOC will contact the applicable equipment vendor and obtain the RMA #. They will log into the applicable trouble ticket and pass the number and shipping instructions to the affected site.



Note: The site is responsible for making shipping arrangements back to the vendor RMA facility.

3. If the component to be repaired/replaced is owned by the site, the site is responsible for the cost associated with shipping. The site is also responsible for the repair/replacement cost if the equipment manufacturer deems the repairs/replacements out of warranty.
4. If the component to be repaired/replaced is owned by AGS and leased to the site, AGS is responsible for the cost associated with shipping. AGS is also responsible for the repair/replacement cost if the equipment manufacturer deems the repairs/replacements out of warranty.
5. Once the repaired/replaced item is received back at the site, the TOC must be notified to provide the equipment make, model, and serial #. The item should be placed in the on-site spares pool until needed.

Network Management

The NCC is the central control for the entire Linkway network. Hosted on a Sun workstation, the NCC software runs as a single application process and performs the following functions:

- Configuration Management
- Acquisition and Synchronization Control
- Bandwidth Management
- Fault Protection
- Accounting
- Performance and Alarm Management
- Security Management

CONFIGURATION MANAGEMENT

The NCC stores all configuration data for the entire Linkway network. Each configuration data file is similar to a file (or a relation) in a regular database management system. The NCC software reads the configuration data into RAM at startup—this RAM copy is used during network operation. The files are written to only when configuration data changes. (For example, additions and deletions to existing data.) The NCC Configuration Management function interfaces with the Java-based NMS (Network Management System) to add, delete, or modify the configuration data. At terminal startup, and upon any configuration changes, the NCC downloads configuration data. If the configuration data changes, the NCC sends modifications to the terminals.

ACQUISITION AND SYNCHRONIZATION CONTROL

See *How Communication is Established Over the Linkway* on page 46 .

BANDWIDTH MANAGEMENT

The Linkway system runs a central bandwidth management program in order to efficiently use space segment and provide high levels of end-user data throughput. The bandwidth management function performs both fixed bandwidth allocation and dynamic bandwidth allocation (bandwidth-on-demand):

- Fixed bandwidth allocation - Certain traffic categories in Frame Relay require bandwidth to be allocated for the entire duration of the call. In these cases, bandwidth is allocated at call (or connection) setup and remains allocated for the entire duration of the call. The bandwidth is de-allocated when the call ends (or the connection is torn down).
- Dynamic bandwidth allocation (bandwidth-on-demand) - Every Linkway terminal runs a Bandwidth Reporter program that continuously monitors the incoming user traffic. The dynamic bandwidth allocation function collects the reports from all traffic terminals and periodically runs an algorithm to distribute available bandwidth resources fairly and efficiently using three levels of fairness:
 - Outgoing Fairness: All connections originating from a particular terminal compete for the terminal's total *transmission* capacity in a fair manner.
 - Incoming Fairness: All connections terminating at a particular terminal compete for the terminal's total *receive* capacity in a fair manner.
 - System Fairness: All connections in the *entire network* compete for the total system capacity in a fair manner. This algorithm provides bandwidth allocation in response to changing incoming user traffic rates in a dynamic manner.

FAULT PROTECTION

Linkway has three levels of fault protection:

- System faults are handled through the NMS and its alarm functions.
- Terminal faults are minimized using redundant- terminal operation for terrestrial interfaces.
- Network faults are minimized in two ways: redundant NCC configuration and redundant MRT configuration.

The NCC can be configured as either locally or geographically redundant. In a geographically redundant configuration, the NCC functions are passed to a standby NCC on a backup Sun workstation located at a different site.

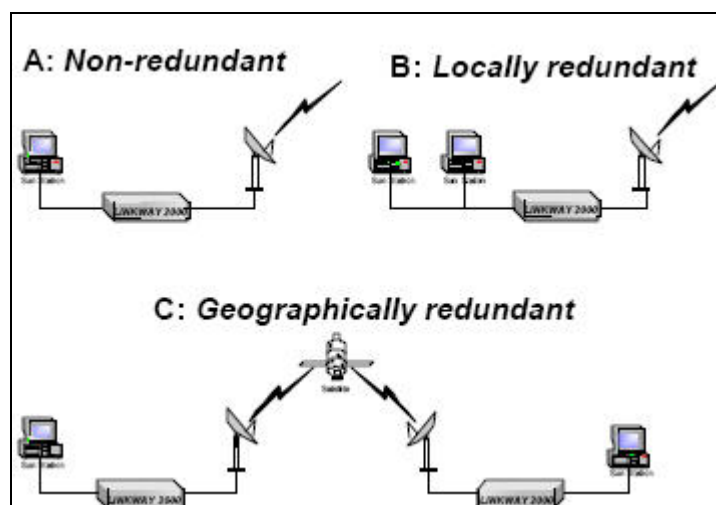

Redundant NCC Options

In redundant MRT cases, the NCC monitors its connection to the MRT and AMRT (Alternate Master Reference Terminal). When it detects that the MRT is not responding, the NCC automatically switches the reference station functions to the AMRT. This switch-over mechanism allows continuous operation of the TDMA network, even when the MRT fails. The Linkway NCC and MRT redundancy scheme offers a single rollover from active to passive unit, ensuring no unscheduled disruption in network synchronization.

ACCOUNTING

The NCC accounting function generates accounting reports for all user calls and connections in IP and Frame Relay. A resource utilization record is written at connection startup and shutdown. The accounting management subsystem's architecture consists of an accounting manager module at each terminal and the NCC communicating over the reliable packet transport protocol.

The NCC accounting manager receives accounting records from all terminal accounting managers and stores them in accounting files. There is one accounting file per service per accounting session, with each accounting session being a 24-hour period.

Each call has a unique call ID that appears in all accounting records written for it. This ID holds across terminal and NCC resets. Intermediate records are generated at the end of every accounting session for calls lasting more than a day. If a terminal fails, appropriate records are generated for ongoing calls. Call beginning and end times are noted in GMT (Greenwich Mean Time), although accounting sessions may end at midnight GMT or local time.

PERFORMANCE AND ALARM MANAGEMENT

The performance management function is useful in monitoring a terminal's health and for diagnosing problems. It enables the NMS operator to view transmit and receive burst data and to collect performance data, such as BER (Bit Error Ratio), link statistics, and IP traffic from individual terminals. The NMS operator can also assess service statistics from the Frame Relay. The NCC collects data for each burst containing the selected connection. Data is gathered for channel access control transmissions to and from the satellite, and for the terrestrial interfaces by link and connection. The operator can collect performance statistics from individual terminals for monitoring the health of a particular terminal and for diagnosing problems. Various fault alarms are collected from the terminals and distributed to the NMS for display on the operator screen. Some of the important parameters monitored are:

- Statistics for each receive burst
- Accumulated statistics for each transmit burst
- Accumulated statistics on a per destination basis (e.g., number of packets sent, allocated packet bandwidth, average number of bytes per sec)
- Packets dropped at a node
- Packets forwarded at a node
- Throughput on the link.

The NCC monitors the following information for each terminal:

- Terminal ID
- Terminal type - MRT, SRT, or TT (Traffic Terminal)
- State - Up/down
- Number of times the terminal has acquired
- Number of acquisition commands sent to the terminal
- Number of status request messages sent to the terminal
- Number of status response messages received from the terminal
- Number of reports received from the terminal
- Total number of calls
- Number of calls rejected
- Number of calls completed normally
- Number of calls abnormally terminated
- Number of calls abnormally terminated due to a network failure
- Current number of calls.

The following statistics are maintained:

- Current port status - Up or down
- Loopback condition detected - Yes or no
- Data packets received for transmission
- Data bytes received for transmission
- Data packets sent to the user
- Data bytes sent to the user
- Number of signaling packets received
- Number of status inquiry packets received
- Number of status packets received
- Number of signaling packets sent
- Number of status inquiry packets sent
- Number of status packets sent
- User procedure signaling errors, e.g., message loss, sequence number, invalid header

-
- Number of times user procedures declared the channel inactive
 - Network procedure signaling errors (message loss, sequence number, invalid header etc.)
 - Number of times network procedures declared the channel inactive

The operator can send diagnostic commands to a terminal or the NCC. The major diagnostic functions that can be executed via the NMS are:

- Verifying TDMA performance by displaying burst statistics. Along with the number of data segments transmitted on each burst, the system reports burst ID and the number of detects, misses, Viterbi (algorithm code) corrections, and CRC (Cyclic Redundancy Check) errors.
- Verifying Frame Relay performance through the Frame Relay connection control process in a terminal, which handles making and breaking connections within the Linkway network.
- Verifying IP performance by providing IP statistics for each terminal in the network with IP traffic.

The alarm management function collects information regarding various terrestrial interface alarms from the terminals and distributes it to the NMS for display on the operator's screen. The system displays information for all active alarms in the system and identifies failures at the interface card level. Alarms are sent only for equipment or interface failure. Service performance or BER levels will not trigger any alarms. In addition, whenever a terminal goes down, or the NMS loses its connection to the NCC, the NMS sounds a continuous beep alarm, and displays the Beep Alarm window. The NMS operator must acknowledge the alarm to turn off the beep.

SECURITY MANAGEMENT

The NCC maintains NMS operator login and password information as part of the configuration data and uses this information to authenticate operators trying to log into the system. The system has three levels of security:

- Full Access - Allows the NMS operator to view and modify all configurable databases.
- Read-Only Access - Allows the NMS operator to view only the configuration data. This privilege can be further specified to limit access to configuration data of one or a set of terminals.
- Restricted Access - Allows the NMS operator to read only portions of the network that have been specified.

Procedures

The procedures for maintaining the MEVA II network consist of:

- General
 - Test Equipment Setup and Use
 - Antenna Peak and POL
 - Sealing Connectors
 - Loading Boot Files in the Linkway 2100
- Preventive Maintenance
 - Monthly
 - Annual
- Corrective Maintenance
 - Fault Isolation
 - Component Replacement
 - Recovery Testing
 - Interference Testing

General

The sections below outline the procedures for setup and alignment of the earth station. Prior to the ODU alignment, the antenna should be set to the desired azimuth and elevation settings per manufacturer's instructions.



Important: The IBUC must not transmit until alignment and any necessary adjustments are complete.

TEST EQUIPMENT SETUP AND USE

The following equipment or equivalent is recommended for installation and system alignment:

Equipment	Type
Spectrum Analyzer	HP8563E
Digital Voltmeter	Fluke 8050
Adapter Waveguide to coax	C-band
RF cables	With calibrated insertion loss up to 15GHz
40 dB attenuator	High Power to match HPA output.
Assortment of cables, connectors and adapters (calibrated up to 15 GHz)	

Recommended Test Equipment



Ensure that the IBUC TX output power is disabled to prevent accidental transmission interference with adjacent satellites or transponders before attempting to align or performing any other operation involving the ODU. Before attempting any system change, carefully evaluate the possible effects of the transmitted signal.

Setting the TX and RX Frequencies

All transmit and receive frequencies are set in the modem. For a direct connection to an L-band modem follow the manufacturer's instructions on setting the transmit and receive frequencies.

Receive L-band Output Measurements

To check the Receiver, perform the following:

1. Ensure that 15-24VDC (LNB Bias) is present at the modem or IFU RX input.
2. Use a spectrum analyzer to ensure that the 10MHz signal is present at the modem or IFU RX input.



Warning: DC power will be present on the cable so the use of a DC block is recommended.

3. Connect the LNB to the demodulator RX input by attaching the coaxial cables from the RX L-band OUT (J1) on the LNB to the demodulator RX L-band input port.

ANTENNA PEAK AND POL (POLARIZATION)



Warning: When aligning the antenna, the IBUC must not transmit.

Ensure that the desired transponder is in operation. To find the satellite and peak the receive signal:

1. Apply power to the LNB.
2. Sweep the antenna through previously determined azimuth and elevation adjustments.



Note: This must be done very slowly in order to locate the satellite.

3. Simultaneously, monitor the RECEIVE signal level at the demodulator. Wideband signals such as video carriers are easiest to find and should be used when available.

Initial Alignment

The 3.8 meter offset reflector contains a 22.62° elevation offset look angle. Therefore, when the reflector aperture is perpendicular to the ground, the antenna is actually looking 22.62° in elevation.

1. Raise the antenna by turning the 2" nuts on the elevation rod assembly.
2. After the correct elevation angle is set, rotate the antenna in azimuth by loosening the 2" nut on top of the positioner and removing the 1" hardware (4 places) in the positioner plate, refer the figure on the following page.
3. Rotate the antenna in azimuth by turning the 1" nuts located at the azimuth adjustment tube. Rotate azimuth until a signal is reached.
4. Peak the antenna by fine adjustments made in both the elevation and the azimuth.
5. Adjust polarization by rotating the feed assembly in its mounting bracket.
6. Re-install the 1" hardware in the Az/EI positioner (from step# 2) and tighten all adjustment hardware securely.

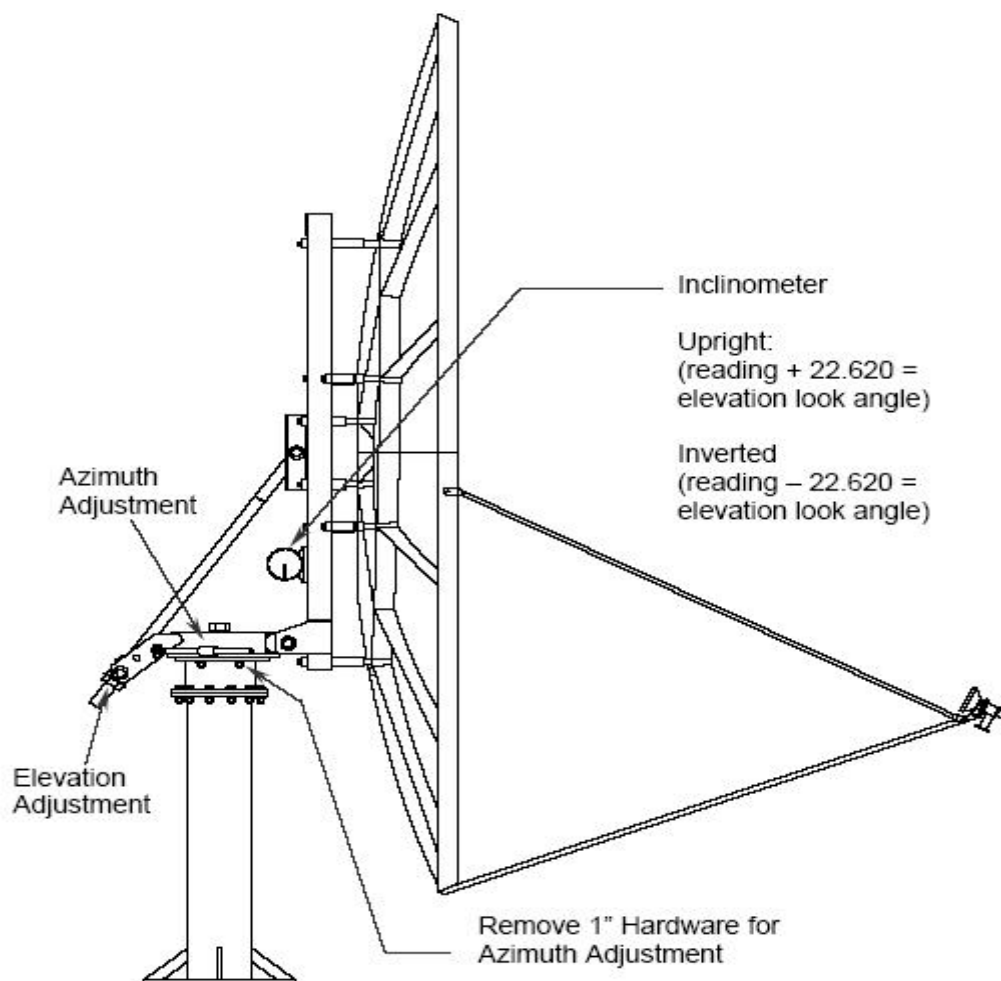

Initial Satellite Alignment

TX Power Alignment

Refer to the following procedures to align the TX (Transmit) power.

Transmit L-band Input Adjustment with Modem/Converter



Warning: DC power will be present on the cable so the use of a DC block is recommended.

To set the power level of the modulator output:

1. With a spectrum analyzer, measure the power level of the L-band signal at the output of the coaxial cable that connects to the IBUC at J1 (TX L-band).
2. Use the modem or converter level adjust to increase and decrease the power level. Adjust this for a level of -30 dBm (this will result in rated power at the IBUC output).
3. Check that the 10MHz reference signal is between +3 and -8 dBm.
4. Disconnect the spectrum analyzer from the coaxial cable.

Transmit RF Output Adjustment with Modem or Converter

To adjust the power level of the IBUC transmitter output:

1. Connect a waveguide to coax adapter and a 40dB high power attenuator to IBUC TX waveguide output.
2. Connect the TX L-band input signal to J1 (TX L-band) on the IBUC.
3. Enable the TX signals in the modem or converter and the IBUC.
4. Measure the RF output with the power meter connected at the waveguide output. For accuracy measure pure carrier.
5. With a Satellite modem: Adjust the RF output to the designated power level (provided by the satellite network operation center, or its engineering staff) with the L-band output (modem) level adjust.
6. Disable the TX signal in the modem or converter.
7. Disconnect the TX L-band input signal.
8. Remove the waveguide to coax transition and install the transmit waveguide section to the antenna transit feed.
9. Once the transmit input and output power levels have been set, begin transmitting by connecting the TX L-band input signal to J1 on the IBUC and enabling the TX in the modem or converter.
10. Under the guidance of the Network Operations Center (NOC), fine adjust the transmit power for the desired down link margin at the receiving station by adjusting the TX L-band output level adjust (modem or converter output).

To ensure optimum operation, inspect the system for crimped or pinched cabling. Make sure all connections are secure. Once the system has been aligned and is operating satisfactorily, the IBUC will require a few infrequent and simple maintenance procedures as described in under ***Fault Isolation of ODUs*** on page 86.

Site Selection

In order to achieve maximum performance of your antenna system, it is important to select the correct location for the antenna. The following guidelines should be observed when selecting a site for the installation.

1. The line of site to the satellite should be clear of any obstruction, such as trees and buildings.
2. The site should be relatively flat and level for ease of installation and access to the antenna.
3. The site should be checked for underground obstruction, such as buried cables or pipes.
4. All local building codes should be adhered to (i.e. grounding, foundation requirements, zoning rules, setbacks, etc.).

SEALING CONNECTORS

All outdoor connectors should be double wrapped with “MoCap” silicon-based sealing tape from the base of the equipment connector to at least ½ inch beyond the crimp ring on the coax connector.

LOADING BOOT FILES IN THE LINKWAY 2100

Refer to the following procedures to load boot files in the Linkway 2100.

1. Login to the Linkway 2100 as an administrator (admin password will be supplied as required).
2. From the *Transfer* drop-down menu, select *Send Text File*.
3. In the *Send Text File* window, select the drive/folder from the *Look-in* drop-down menu.
4. From the *Files of Type* drop-down, select *Text Files*.
5. Select the boot file that corresponds to the terminal and click the *Open* button (This file downloads the boot file to the terminal.) The download is complete when a checksum line appears on the screen.
6. Compare the “echo expected checksum” with the checksum that appears at the bottom of the boot file window. If they are exactly the same, the download was successful. If not, repeat the download by reopening the download file.
7. When finished, issue “hw” to reboot the terminal.

Preventive Maintenance

Preventive maintenance of the MEVA II network involves:

- Properly mounted ODUs
- Proper grounding and lightning protection of the IBUC/PSUI
- Monthly Maintenance
- Annual Maintenance

ODUs

The ODU must be mounted so that:

- Sufficient support is afforded the IBUC, the LNB and the PSUI to minimize the effects of antenna sway in strong winds.
- Air movement across the heat fins is possible.
- The fan shroud (IBUC and PSUI) is mounted so that the louvers are facing the ground.
- The fan intake and exhausts are free from any obstruction.
- The length of the PSUI cables is taken into consideration in determining the mounting location of the PSUI.

Throughout installation and during any polarization, azimuth or elevation adjustment, ensure that cables and waveguide are not crimped or pinched.

IBUC/PSUI GROUNDING RECOMMENDATIONS

Grounding and lightning protection is recommended as follows.

- Cable Shielding: The shield currents can be eliminated with proper techniques. A grounding strap at the end of the coaxial and data cables should be connected to the ground lug at the antenna base with a #4 gauge copper wire. This provides a path of least resistance prior to entering the electronic equipment.
- AC: The best way to protect the equipment is to have two protectors. The first is the power mains protector that is mounted directly across the mains in the breaker box. The second should be mounted or grounded directly at the base or hub of the antenna or at the 19 inch rack.
- Data and Control Lines: The I/O lines can deliver surge current to the equipment and should be protected.

- Electrical grounding: Grounding of the IBUC and PSU units is recommended to prevent possible damage from lightning and/or other induced electrical surges. It is recommended that 3/0 or 4/0 AWG (American Wire Gauge) stranded copper wire be used to bond the
- IBUC and the PSU to the earth ground (grounding rod), using the most direct (shortest) route.

PERIODIC INSPECTION OF THE PRODELIN ANTENNA

It is suggested that a periodic inspection be performed at least every six months.



Note: After any very severe weather condition, inspection of the antenna should be performed to determine if foreign objects have caused damage or if survival specification have been exceeded.

This inspection should include the following:

1. Check all bolting locations - all bolts should be tight.
2. Check all structural members - repair or replace if damaged.
3. Check the foundation anchor bolts - they must be secure and have no failure signs in the foundation.
4. Check for corrosion - on the reflector structure and the mount.

Reflector

Prodelin's reflector does not require any maintenance. The composite construction of the reflector prevents most damage that could be caused by weather or other atmospheric conditions. It is only necessary to inspect for any physical damage done by vandalism or very severe weather conditions. Should any damage be detected to a portion of the reflector, contact the Customer Service Department at Prodelin for recommendation involving reflector repair.

Mount and Reflector Support Structure

The mount and reflector support structure supplied with this antenna is of steel construction and has a galvanized finish with zinc w/ultraguard finish for hardware. If inspection shows any sign of structural failure, the mount members that are damaged should be repaired or replaced. Any corrosion on steel members may be repaired with a cold, n zinc rich galvanizing paint.

Feed and Feed Support

The feed support tube and feed rods should be inspected to insure that all hardware is secure. The feed and radio mounting bolts should be tight. The feed window should be inspected to insure that it is intact so that no moisture can collect inside the feed. Replace if damaged.

MONTHLY MAINTENANCE

For monthly maintenance of the MEVA II network, do the following:

- Periodic Line Testing
- Visual Inspection for dust, bee/bird's nests on ODUs.

EVERY SIX MONTHS

Every six months, do the following maintenance to the MEVA II network:

1. Grease the elevation and azimuth jacks screws (unless they are painted).
2. Grease the azimuth and elevation pivot points.
3. Remove the allen screws (one at a time) on the IBUC and PSU and apply antiseize compound.
4. On Andrew 4.5 meter antenna, remove azimuth and elevation set screws (one at a time) and apply antiseize compound to the lower half of the threaded sockets.

ANNUAL MAINTENANCE

For annual maintenance of the MEVA II network, do the following:

1. Perform six-month maintenance as described above.
2. Peak the azimuth, elevation and polarization of the antenna.
3. Clean and inspect the surface of the antenna reflector, looking for signs of deterioration in the surface gelcoat.

Corrective Maintenance

For corrective maintenance that involve outages, contact the TOC (Technical Operations Center) through the following methods:

In the event of a problem, contact the TOC through the following methods:

- MEVA II network 2400 and 2401
- Landline 1-866-244-5012
- Non-toll-free number 410-970-7700
- E-mail address nmcsupport@ses-amicom.com

Corrective maintenance of the MEVA II network also involves:

- Fault Isolation of ODUs
- Component Replacement
- Recovery Testing
- Interference Testing

FAULT ISOLATION OF ODUs

The Terrasat PSUI's and ODU's are self-contained units that require very little maintenance. In order to maintain the 120 voltage or 60Hz, refer to the following fault isolation tips.

Standard Maintenance

For optimum performance, inspect the mechanics of the system every six months. Clean the antenna feeds as necessary to keep them clear of obstructions and check the cables and connectors for signs of wear, damage or loose connections. Check all fan intakes and exhausts to ensure that they are free and clear of debris (bee or bird nest, etc.)

Transceiver Fault Isolation

The following information does not help determine whether a Terrasat PSUI or ODU is faulty. The goal is to determine a "GO" or "NO GO" situation based on alarms indicated through the M&C ports and measuring certain signals using test equipment.

AC Power Problems/Conditioning

There are many types of power-related problems that prevent proper operation of sensitive electronic equipment. Examples of these noise problems or disturbances are:

- Voltage induced by lightning
- Switching on/off high power electrical equipment
- Utility company actions such as power factor correction

Serious problems can result from transients (rapid increase/decrease in voltage) and spikes (rapid increase in voltage), such as random errors or failure of the PSUI circuitry. These problems can be avoided using the Liebert UPS.

Site-Related Problems

VSAT antennas are often fitted on top of buildings. Avoid close proximity to elevator motors, etc. Also ensure that the satellite signal path is free and clear of obstructions.

M&C Checks

The first level of troubleshooting the IBUC is to check the status through the M&C ports. Alarms and an alarm history are available in the IBUC M&C port.

Power Supply Checks

- Before starting the RF troubleshooting, verify that the proper voltages are being supplied to the IBUC.
- Verify that the values for the input DC Voltage and IBUC current consumption data are within limits. (The data is available from the IBUC M&C port.)
- IF M&C is not available, use a multimeter to verify that the appropriate voltages (24VDC or 48VDC) that are present at the IBUC. The labeling on the IBUC has the required voltage (24VDC or 48VDC). The IBUC DC supply may be through connectors J1 or J3:
 - J1 - connects to the satellite modem (L-band, 10MHZ VDC, FSK)
 - J2 - connects to the M&C port (TCP/IP, RS232)
 - J3 - connects to the power supply (VDC)

Transmit Power Setting

There have been several cases where the transmit power has been turned up to or near saturation while transmitting a digital carrier. This can result in spectral distortion, i.e., "shoulders", "ears", etc. When transmitting digital carriers, it is recommended to operate the power amplifier system with an OBO (Output Back Off) sufficient to meet the spectral density mask requirements.

TX IF Input Level Verification

If low or no TX (transmit) output power is detected, check the input to the IBUC and refer to the following procedures.



Important: DC power may be present on the cable so the use of a DC block is recommended.

1. Check the TX Input Level displayed in M&C or disconnect the cable at the IBUC J1 and use a spectrum analyzer to measure the power level of the L-band signal at the output of the coaxial cable that connects to the IBUC at J1. The L-band signal level should be between -20 and -45 dBm (decible referenced to 1 milliwatt). If it is not, check the cable and modem output.
2. If the L-band signal is good, check that the 10MHz-reference signal is between $+3$ and -8 dBm and is distortion free. If it is not, check the cable and modem output.
3. If the L-band and 10MHz signals are good, check that the DC voltage level is within range. For 10 watt and lower power units only the DC voltage may be on the L-band IFL or from a separate power supply. For higher power units, the DC voltage will be on the DC cable that is connected to the IBUC J3 (DC Input). If it is not, check the PSU1 or modem power supply outputs and cables.

4. If the L-band, 10MHz and DC voltage signals are good, proceed to the IBUC TX Output verification.
5. Disconnect the spectrum analyzer from the coaxial cable.

IBUC TX Output Verification



Note: This is on the assumption that the L-band, 10MHz and DC inputs are at the correct levels. Verify the following:

- TX Output level is monitored and displayed in the IBUC M&C. Alternatively, connect a waveguide to coax adapter and a 40dB high power attenuator to the IBUC TX waveguide output.
- Measure the TX RF output with the spectrum analyzer connected at the waveguide output. Ensure that the cable loss of the cable being used for the measurement has been taken into account.
- The RF power should be between rated power and rated power –25 dB. If it is not, the IBUC is defective and should be returned to the factory for repair.
- If the IBUC TX RF output measures good, check the waveguide, feed and antenna for proper operation.

Receive L-band Output Verification

If low or no RX output power is detected, start the troubleshooting by checking the output of the LNB. Refer to the following procedures.

1. Ensure that the 15-24VDC (LNB Bias) is present at the modem RX input using a DVM. If it is not, check the cable and modem.
2. Use a spectrum analyzer to ensure that the 10MHz signal is present at the modem RX input. If it is not, check the cable and modem.
3. Connect the LNB to the demodulator by attaching the coaxial cables from the RX L-band OUT (J1) on the LNB to the demodulator RX L-band input port. If the RX level is low check the cable, the feed and antenna for proper operation.



Important: DC power may be present on the cable so the use of a DC block is recommended.

Repair Policy

The Terrasat IBUC and PSUI are not field repairable. In the event that a failure has been detected, it may be necessary to return the defective unit to the factory.

COMPONENT REPLACEMENT

For the LNB, disconnect the RX cable from the N connector and remove the bolts that hold the LNB to the feed. Install the new LNB, ensuring that the new gasket is in between the flanges on the LNB and feed.

For the BUC, Linkway 2100, and Memotec 960e, refer to the following manuals to replace components:

Linkway 2100 Technical Manual

Memotec 960e Technical Manual

Terrasat BUC Technical Manual

RECOVERY TESTING

After each part has been repaired, call the TOC so they can verify that all services have been restored and operating within acceptable parameters.

INTERFERENCE TESTING

To determine if the noise floor has been raised and/or a rogue carrier has been introduced that is interfering with the MEVA II carrier groups:

Compare the current spectrum analyzer displays at the site (at 10, 100 and 500 MHz span centered on the primary MEVA II carrier frequency of 1311.375 MHz and on the center of the L-Band spectrum of 1200 MHz) to the captured spectrum analyzer plots saved for each site. (During annual maintenance, plots are saved for each site that are used a point of reference.)

MEVA II Acronyms, Abbreviations and Terms

ACC - Area Control Center. Also known as a Center, a facility responsible for controlling instrument flight rules that apply to aircraft en route in a particular volume of airspace at high altitudes between airport approaches and departures. In the United States, such a Center is referred to as an Air Route Traffic Control Center (ARTCC). A Center accepts traffic from, and passes traffic to, the control of a Terminal Control Center or another Center. The general operations of Centers world-wide, and the boundaries of the airspace each Center controls, are governed by the International Civil Aviation Organization (ICAO). See also *ARTCC* and *ICAO*.

ADPCM - Adaptive Differential PCM. A form of Pulse Code Modulation (PCM) that produces a digital signal with a lower bit rate than standard PCM. ADPCM produces a lower bit rate by recording only the difference between samples and adjusting the coding scale to accommodate large and small differences. See also *PCM*.

AFSS - Automated Flight Service Station (FAA). An air traffic facility which provides automated (recorded) pilot briefings about current weather and possible hazards along a flight route. A FSS may also give en route communication services and Visual flight rules (VFR) search and rescue (SAR) assistance. Other responsibilities include relaying Air traffic control (ATC) clearances, creating Notice to Airmen (NOTAMs), receive Instrument flight rules (IFR) flight plans and monitor Navigation Aids (NAVAIDs).

AFTN - Aeronautical Fixed Telecommunication Network. A worldwide system of aeronautical fixed circuits provided as part of the aeronautical fixed service, for the exchange of messages and/or digital data between aeronautical fixed stations having the same or compatible communications characteristics. AFTN comprises aviation entities including: ANS (Air Navigation Services) providers, aviation service providers, airport authorities and government agencies, to name a few. It exchanges vital information for aircraft operations such as distress messages, urgency messages, flight safety messages, meteorological messages, flight regularity messages and aeronautical administrative messages.

AFTN addresses are 8 characters long and comprise of the 4-letter ICAO station code and 4-letter facility code. ZTZX refers to Control Tower, ZPZX refers to Terminal Control Center and ZQZX refers to Area Control Center. IATA teletype addresses are 7 characters long.

Messages can be given a message priority to ensure best use of the system. SS relates to a Mayday priority, DD an Urgency priority, FF and GG a normal priority and KK a low priority.

AGC - Automatic Gain Control. An M&C feature of the IBUC that continuously monitors output. If a change in the TX (Transmit) output level is detected, the input to the IBUC is checked to see if it has changed. If the input has not changed, the IBUC adjusts the gain of the system in 0.1 dB steps to maintain a set gain value.

ALC - Automatic Level Control. Similar to the AGC system, the IBUC monitors output and adjusts gain to maintain a constant output level. See also *AGC*.

AIC - Analog Interface Controller. Provides bi-directional analog interfaces to the voice SLIM LIDs. The analog interface between the SLIM LIDs and the AICs are differential to minimize noise. See also *SLIM LIDs*.

AMRT - Alternate Master Reference Terminal. This terminal serves as the backup for the MRT in the event that the MRT goes down. The redundant AMRT is located in Woodbine, MD.

ANSI - American National Standards Institute. A private nonprofit organization that oversees the development of voluntary consensus standards for products, services, processes, systems, and personnel in the United States. The organization also coordinates U.S. standards with international standards so that American products can be used worldwide. These standards ensure that the characteristics and performance of products are consistent, that people use the same definitions and terms, and that products are tested the same way. ANSI also accredits organizations that carry out product or personnel certification in accordance with requirements defined in international standards.

ARTCC - Air Route Traffic Control Center (FAA). A facility that provides air traffic control service to aircraft operating on flight rules within controlled airspace during the en route phase of flight. An ARTCC is the U.S. equivalent of an Area Control Center (ACC).

ATC - Air traffic controllers. A service provided by ground-based controllers who direct aircraft on the ground and in the air. A controller's primary task is to separate certain aircraft — to prevent them from coming too close to each other by use of lateral, vertical and longitudinal separation. Secondary tasks include ensuring safe, orderly and expeditious flow of traffic and providing information to pilots, such as weather, navigation information and NOTAMs (Notices to Airmen).

ATN - Aeronautical Telecommunications Network. An internetwork architecture which allows ground, air-to-ground, and avionics data subnetworks to interoperate by adopting common interface services and protocols based on the International Organization for Standardization (ISO) Open Systems Interconnection (OSI) reference model.

BER - Bit error rate. The percentage of bits that have errors relative to the total number of bits received in a transmission, usually expressed as ten to a negative power. For example, a transmission might have a BER of 10 to the minus 7, meaning that, out of 1,000,000 bits transmitted, one bit was in error. The BER is an indication of how often a packet or other data unit has to be retransmitted because of an error. Too high a BER may indicate that a slower data rate would actually improve overall transmission time for a given amount of transmitted data since the BER might be reduced, lowering the number of packets that had to be resent.

BoD - Bandwidth on Demand. A temporary shared bandwidth that is used for the dial-up phone lines. The total amount of bandwidth available is 500k, and 16k is used during each phone call.

BUC - Amplifier Block-Up Converter. Used in the transmission (uplink) of satellite signals. It converts a band (or "block") of frequencies from a lower frequency to a higher frequency. Modern BUCs convert from the L band to Ku band, C band and Ka band. Older BUCs convert from the 70 MHz band to Ku band or C band. BUCs are used in conjunction with LNBS (Low-Noise Amplifier Block-Down Converter). The BUC, being an up-converting device, makes up the "transmit" side of the system, while the LNB is the down-converting device and makes up the "receive" side. An example of a system utilizing both a BUC and an LNB is a VSAT system, used for bidirectional Internet access via satellite.

Burst - A temporary transmission that makes BoD possible. See also *BoD*.

CAA - Civil Aviation Administration. Consists of global ATCs around the world. See also *ATC*.

CAR/SAM - Caribbean/South American. Caribbean and South American regions.

CBTR - Carrier and Bit Timing Recovery. A burst data pattern that aids receiving modems in obtaining carrier and symbol clock acquisition.

CCITT - ITU Consultative Committee on International Telephone and Telegraph. An organization that sets international communications standards. CCITT is now known as ITU (the parent organization). See also *ITU*.

CELP - Code Excited Linear Prediction. The most widely used speech-coding algorithm.

Co-Pol - Co-Polarization. Transmitting and receiving in the same polarization.

C/N - Carrier to Noise Ratio. A measure of signal strength relative to background noise. The ratio is usually measured in decibels (dB). The goal is to maximize the C/N ratio by:

- Using the narrowest receiving-system bandwidth consistent with the data speed desired.
- Spreading spectrum techniques.
- Providing the source with a higher level of signal output power if necessary.

C/N is also known as S/N or SNR (Signal to Noise Ratio).

CNS - Communications, Navigation and Surveillance. Often associated with air traffic management.

CODEC - Coder- Decoder. A device or program capable of performing encoding and decoding on a digital data stream or signal. For example, telephone companies use codecs to convert binary signals transmitted on their digital networks to analog signals converted on their analog networks.

COTS - Commercial-Off-The-Shelf. Technology or computer products that are ready-made and available for sale, lease, or license to the general public.

CPDLC - Controller-Pilot Data Link Communications. A method by which air traffic controllers can communicate with pilots over a datalink system. CPDLC is also referred to as Controller Pilot Data Link (CPDL).

DAMA - Demand Assigned Multiple Access. A satellite channel access protocol that provides a highly efficient means of instantaneously assigning channels in a transponder according to immediate traffic demands. DAMA matches user demands to available satellite capacity.

Data Packet - A formatted block of data carried by a computer network. When data is formatted into a packet, the network can transmit longer messages more efficiently and reliably.

DAV - Dual Analog Voice. A type of I/O card. FXS (Foreign Exchange Station) and E&M (Ear and Mouth) cards plug into LID (Line Interface Driver) sockets on the DAV I/O card. The FXS port is used to provide the switched voice while the E&M card is used at sites with voice shutdown lines. See also *FXS*, *E&M* and *LID*.

DCA - Director of Civil Aviation. The director civil aviation, which includes two major categories:

- Scheduled air transport, including all passenger and cargo flights operating on regularly-scheduled routes.
- General aviation (GA), including all other civil flights, private or commercial.

dBm - Decibel referenced to 1 milliwatt.

DCE - Data Communications Equipment. A device that communicates with a DTE (Data Terminal Equipment) device. The V.24 Serial I/O Card's port is configured as a DCE device. See also *DTE*.

DDS - Direct Digital Synthesizer. Minimizes timing error in the Linkway system. Each Linkway terminal automatically monitors and adjusts its DDS to match that of its MRT or supporting reference terminal.

DLC - Data Link Connection Identifier. Linkway performs frame switching and forwarding on a DLC basis. Multiple connections (DLCIs) can be provisioned to multiple destinations. Each connection is configured with bi-directional CIR (Committed Information Rate), committed Bc (burst size), and Be (excess burst size) as QoS (Quality of Service) parameters. See also *DCLI*.

DLCI - Data Link Connection Identifier. A channel number which is attached to frame relay data frames to tell the network how to route the data. A 10-bit field that defines the destination address of a packet. The address is local on a link-by-link basis. Frame relay is statistically multiplexed, which means that only one frame can be transmitted at a time but many logical connections can co-exist on a single physical line. The DLCI allows the data to be logically tied to one of the connections, so that once it gets to the network it knows where to send it.

DSP - Digital Signal Processor. The core of the DAV I/O card. The DSP uses fixed-point arithmetic suitable of G.729 compression. A 64k x 16 SRAM provides external memory to the DSP.

DTE - Data Terminal Equipment. Defines the two ends of the communications channel as being a DTE and DCE (Data Communications Equipment) device. The V.35 H Serial I/O Card's port is configured as a DTE device. See also *DCE*.

DTMF - Dual Tone Multi-Frequency. Touch-tone telephone service. A tone is generated as each telephone key is pressed.

Eb/No - Energy per bit divided by Noise Spectral Density. A parameter used in digital communication or data transmission. Eb/No can be recognized as a normalized SNR (Signal-to-Noise Ratio) measure. It is typically used to compare the BER (Bit Error Rate) performance of different digital modulation schemes. See also *BER*.

E&M - Ear and Mouth. Type of voice circuit. A four-wire analog voice circuit that is used for the voice shout down on the MEVA II network. The E&M I/O card plugs into the DAV (Dual Analog Voice) I/O card. See also *DAV*.

ESD - Electrostatic Discharge. The rapid discharge of static electricity from one conductor to another of a different potential. An electrostatic discharge can damage integrated circuits found in computer and communications equipment.

FAA - Federal Aviation Administration. An agency of the United States Department of Transportation which regulates and oversees all aspects of civil aviation in the U.S. The Federal Aviation Administration major roles include:

- Regulating U.S. commercial space transportation
- Encouraging and developing civil aeronautics, including new aviation technology
- Regulating civil aviation to promote safety
- Developing and operating a system of air traffic control and navigation for both civil and military aircraft
- Researching and developing the National Airspace System and civil aeronautics
- Developing and carrying out programs to control aircraft noise and other environmental effects of civil aviation

FEC - Forward Error Correction. A method of communicating data that corrects errors in transmission on the receiving end.

FRAD - Frame Relay Access Device. A device that turns data packets into Frame Relay frames that can be sent over a Frame Relay network. The FRAD turns the received Frame Relay frames into data packets. Example of a FRAD is a Memotec 960e. See also *Memotec*.

FR - Frame Relay. A wide area networking method used to send digital information quickly and cheaply in a relay of frames (data packets) to one or many destinations from one or many end-points.

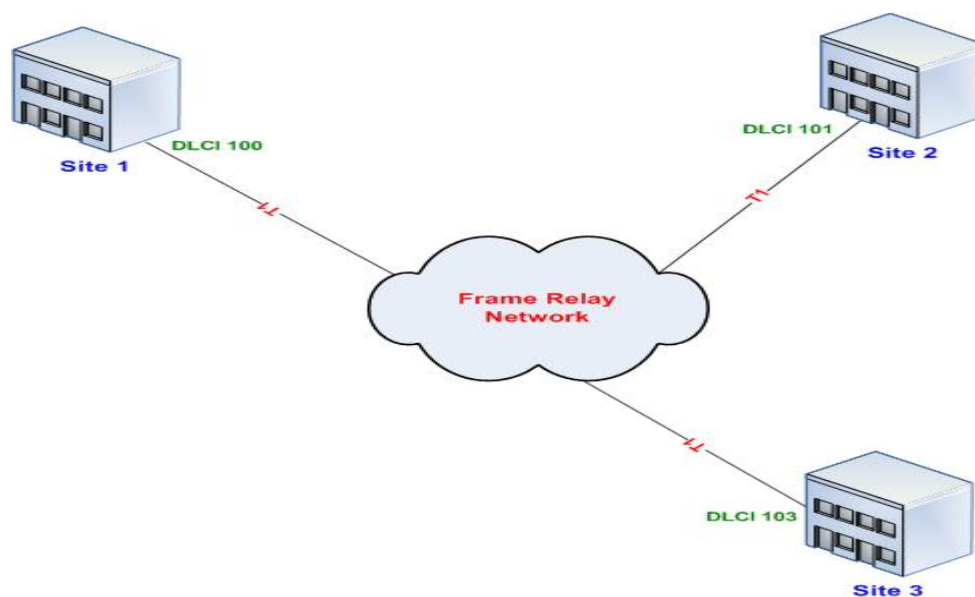

FSK - Frequency Shift Keying. A form of frequency modulation in which the modulating signal shifts the output frequency between predetermined values.

FXO - Foreign Exchange Operation. The interface device for connecting to an analog PBX extension. See Also *VoIP*.

FXS - Foreign Exchange Station. Type of voice circuit that is used for the switched voice on the MEVA II network. The FXS I/O card plugs into the DAV (Dual Analog Voice) I/O card. See also *DAV*.

GNSS - Global Navigation Satellite System. Satellite-based navigation systems that use triangulation to locate a position via calculations from multiple satellites. Each satellite transmits coded signals at precise intervals. The receiver converts signal information into position, velocity, and time estimates. Using this information, any receiver on or near the earth's surface can calculate the exact position of the transmitting satellite and the distance (from the transmission time delay) between it and the receiver. Coordinating current signal data from four or more satellites enables the receiver to determine its position. See also *triangulation*.

GREPECAS - CAR/SAM Regional Planning and Implementation Group. The planning and implementation group for both the CAR (Caribbean) and the SAM (South America) regions. It is assisted by the 2 Regional Offices ICAO has in those regions, in Mexico City (Mexico) and in Lima (Peru).

Hub - The main MEVA II site. In a hub and spoke topology, all remote sites communicate with the hub.

Hub and Spoke Topology - The data portion of MEVA II is configured as hub & spoke where Miami FL is the hub and the 13 remote sites are the spokes.

ICAO - International Civil Aviation Organization. An agency of the United Nations, codifies the principles and techniques of international air navigation and fosters the planning and development of international air transport to ensure safe and orderly growth. The ICAO Council adopts standards and recommended practices concerning air navigation, prevention of unlawful interference, and facilitation of border-crossing procedures for international civil aviation.

IDU - Indoor Unit. Any telecommunications equipment that is used indoors. Examples of IDUs include any equipment in equipment racks, such as a satellite modem or a FRAD (Frame Relay Access Device). See also *FRAD*.

IFL - Inter-facility Link. The cabling connecting a satellite dish and an LNB to the decoding equipment, such as an IRD (Integrated Receiver/Decoder). See also *LNB* and *IRD*.

IP - Internet Protocol. The computer networking protocol used on the Internet.

IRD - Integrated Receiver/Decoder. An electronic device used to pick-up a radio-frequency signal and convert digital information transmitted in it.

ITU - International Telecommunications Union. An intergovernmental organization through which public and private organizations develop telecommunications. ITU is responsible for adopting international treaties, regulations and standards governing telecommunications.

Keepalive - A message sent by one device to another to check that the link between the two is operating.

Kbps - Kilobits per second. A unit of data transfer rate equal to 1,000 bits per second.

LED (Light Emitting Diode) - A light which indicates the system status on the IBUC and Memotec960e CPU.

Link Budget - Series of calculations used to determine the antenna size and transmitter power required for a specific location.

Linkway - Satellite modem that connects advanced business networking applications that use IP and Frame Relay protocols between many remote sites. Linkway VSATs help save satellite bandwidth costs through automatic, adaptive assignment and advanced coding. MEVA II utilizes the IP (Internet Protocol) and FR (Frame Relay) functionality of the Linkway 2100 model. See also *IP*, *FR*, and *VSAT*.

LMI - Local Management Interface. A signaling standard used between routers and frame relay switches. Communication takes place between a router and the first frame relay switch in which it is connected. Information about keepalives, global addressing, IP Multicast and the status of virtual circuits is commonly exchanged using LMI. See also see *Keepalives*.

LNB - Low-Noise Amplifier Block-Down Converter. Used in communications satellite (usually broadcast satellite) reception. The LNB is usually fixed on or in the satellite dish. The purpose of the LNB is to take a wide block (or band) of relatively high frequencies, amplify and convert them to similar signals carried at a much lower frequency. These lower frequencies travel through cables with much less attenuation (reduction in amplitude and intensity) of the signal, so there is much more signal left on the satellite receiver end of the cable. It is also much easier and cheaper to design electronic circuits to operate at these lower frequencies, rather than the very high frequencies of satellite transmission.

LNB

M&C - Monitor & Control. A system that monitors and troubleshoots the MEVA II network. The M&C system may include SNMP (Simple Network Management Protocol) and COTS software. See also *COTS* and *SNMP*.

Memotec - A multiplexer that converts voice and data communication into separate components to be sent through separate ports, such as FXS, V.32 H, and V.24.

MEVA II - MEVA II is a TDMA (Time Division Multiple Access) satellite-based frame-relay network used for Air Traffic Control (ATC) in the Caribbean and Central America regions. It provides voice and data communication between control towers in the following 15 locations:

- Miami, FL (the main hub and FAA site)
- Woodbine, MD (the alternate hub)
- Georgetown, Cayman Islands
- COCESNA (Teguciagalpa, Honduras)
- Panama City, Panama
- Havana, Cuba
- Port-au-Prince, Haiti
- Kingston, Jamaica
- Santo Domingo, Dominican Republic



- Freeport, Bahamas
- Nassau, Bahamas
- San Juan (an FAA site)
- Phillipsburg, St. Maarten
- Curacao, Netherland Antilles
- Oranjestad, Aruba

Ms - Milliseconds.

MRT - Master Reference Terminal. A Linkway 2100 unit configured to be the MRT that controls timing and resource allocation of the MEVA II network. The MRT is located at the Miami hub along with the NCC. See also *Linkway*.

MTBF - Mean Time Between Failure. The average time a device will function before failing. MTBF ratings are measured in hours and indicate the sturdiness of hard disk drives and printers.

MTTR - Mean Time To Repair. The average time before an electronic component can be expected to require repair.

NACC - North American, Central American, and Caribbean (Office).

NADIN - NAS Aeronautical Digital Information Network. The old name for AFTN. See *AFTN*.

NAS - National Airspace System. An interconnected system of airports, air traffic facilities and equipment, and navigational aids and airways.

NCC - Network Control Center. Hosted on a Sun Microsystems workstation, it is the central control for the Linkway network.

NCS - Network Control System. A feedback control system where the control loops are closed through a real-time network. In the NCS, the control and feedback signals are exchanged among the system's components in the form of information packets through a network. The functionality of a typical NCS is established by the use of four basic elements:

- Sensors, to acquire information
- Controllers, to provide decision and commands
- Actuators, to perform the control commands and
- Communication network, to enable exchange of information

NMC - Old name for TOC (Technical Operations Center). See *TOC*.

NMS - Network Management System. A combination of hardware and software used to monitor and administer a network.

ODU - Outdoor Unit. Any telecommunications equipment that is used outdoors. Examples of ODUs are BUCs (Amplifier Block-Up Converters) and LNB (Low-Noise Amplifier Block-Down Converter). See also *BUC* and *LNB*.

PABX - Private Automatic Branch Exchange. A telephone exchange that serves a particular business or office, as opposed to one that a common carrier or telephone company operates for many businesses or for the general public.

PBX - Private branch exchange, a private telephone network used within a large organization. Users of the PBX share a certain number of outside lines for making telephone calls external to the PBX.

PCM - Pulse Code Modulation. A sampling technique used for digitizing analog signals, especially audio signals. PCM samples the signal 8000 times a second; each sample is represented by 8 bits for a total of 64 Kbps. PCM is used with T-1 and T-3 carrier systems. These carrier systems combine the PCM signals from many lines and transmit them over a single cable or other medium.

PLD - Programmable Logic Device. Performs three main functions:

- An interface between the motherboard
- A logic interface between the DSP and SLIM LIDs
- A clock distribution circuit for AICs and the DSP

See also *DSP*, *SLIM*, and *AIC*, *LIDs*.

PSTN - Public Switched Telephone Network. The international telephone system based on copper wires carrying analog voice data. The PSTN is based on older technology. Newer telephone networks use digital technologies, such as FDDI (Fiber Distributed Data Interface). See also *FDDI*.

PTT - Post, Telephone and Telegraph. A government agency responsible for postal mail, telegraph, and telephone services in many countries worldwide other than North America and Japan.

PVC - Permanent Virtual Circuit. A virtual circuit that is permanently available. The only difference between a PVC and a Switched Virtual Circuit (SVC) is that an SVC must be reestablished each time data is sent. Once the data has been sent, the SVC disappears. PVCs are more efficient for connections between hosts that communicate frequently. PVCs play a central role in Frame Relay networks. See also *SVC*.

QoS - Quality of Service. Parameters specifying how many packets or cells can be lost during a transmission, how long it can take for packets or cells to reach their destination, and how much the amount of time between cells can vary. These parameters are used to determine the quality of service a given virtual circuit will provide.

QPSK - Quadrature Phase Shift Keying. A digital modulation scheme that conveys data by changing or modulating the phase of a reference signal (the carrier wave). It is common to configure the traffic bursts with QPSK (Quadrature Phase Shift Keying) modulation to increase user information throughput.

QUICC - Quad Universal Integrated Communication Controller. Located in the processing section in the Motherboard of the Memotec 960e. It contains four SCC (Serial Communication Controllers) which serve I/O card slots 1 to 4. The device operates at 32.768MHz. It is located at U10. An additional QUICC is required when certain I/O cards are installed in I/O slots 5 to 8. This QUICC is located on the Serial Expansion Module (SEM) which is a plug-in card inserted into a 144-pin SODIMM (Small Outline Dual Inline Memory Module) connector on the motherboard (J11).

RIP - Routing Information Protocol. An interior gateway protocol that specifies how routers exchange routing table information.

SCC - Serial Communication Controllers. See *QUICC*.

SCPC - Single Channel Per Carrier. A VSAT satellite transmission system that uses a separate carrier for each of its channels. SCPC is used for broadcast data and full-duplex audio/video communications. In an SCPC system, transmissions are sent to the satellite continuously on a single satellite carrier. The satellite signal is received at a single location, in the case of a point-to-point system, or at many locations in a broadcast system, providing hubless connectivity among multiple sites. See also *VSAT*.

SDRAM - Synchronous Dynamic Random Access Memory. A type of dynamic random access memory that can run at much higher clock speeds than conventional memory.

SEM - Serial Expansion Module. See *QUICC*.

SLIM LIDs - SLIM Line Interface Drivers. Cards plug into the LID sockets on the DAV I/O card. The SLIM LIDs that are used for the MEVA II sites are FXS and E&M. See also *DAV*, *FXS*, and *E&M*.

SNMP - Simple Network Management Protocol. A set of protocols for managing complex networks. SNMP works by sending messages, called protocol data units (PDUs), to different parts of a network.

SODIMM - Small Outline Dual Inline Memory Module. See *QUICC*.

SOF - Start-of-Frame. A point that represents the beginning of the first symbol of a reference burst in a frame. Each carrier in a multicarrier operation transports a TDMA frame that is time aligned with all other carriers' frames on SOF, SOMF (Start of Multiframe), and SOCF (Start of Control Frame).

SSPA - Solid State Power Amplifier. A device that amplifies the signal to the proper level to sustain quality communications as calculated by the Link Budget. See also *Link Budget*.

Star Topology - A local-area network (LAN) or other communications system that is shaped like a star (see illustration below). All devices are connected to a central hub. Star networks are relatively easy to install and manage, but bottlenecks can occur because all data must pass through the hub. The VSAT uses star topology. See also *VSAT*.

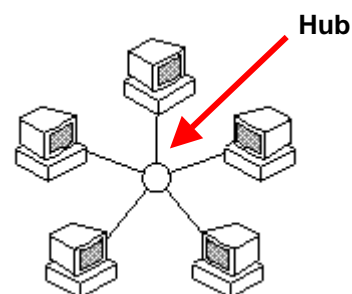

SVC - Switched Virtual Circuit. A temporary virtual circuit that is set up and used only as long as data is being transmitted. Once the communication between the two hosts is complete, the SVC disappears. In contrast, a permanent virtual circuit (PVC) remains available at all times. See also *PVC*.

TDM - Time Division Multiplexing. A type of multiplexing that combines data streams by assigning each stream a different time slot in a set. TDM repeatedly transmits a fixed sequence of time slots over a single transmission channel. Within T-Carrier systems, such as T-1 and T-3, TDM combines Pulse Code Modulated (PCM) streams created for each conversation or data stream. See also *PCM*.

TDMA - Time Division Multiple Access. A technology for delivering digital wireless service using TDM (Time-Division Multiplexing). TDMA works by dividing a radio frequency into time slots and then allocating slots to multiple calls. In this way, a single frequency can support multiple, simultaneous data channels. See also *TDM*.

TMG - Technical Management Group. This TMG is responsible for:

- Reviewing and recommending approval or rejection of Service Provider plans and schedules related to implementation and transition activities.
- Approving the number of VSAT terminal locations and types of telecommunications services to be provided by the Service Provider.
- Ensuring that the Service Provider provides regularly scheduled equipment maintenance and emergency repairs when required, system monitoring, control trouble diagnosis, repairs, and training for MEVA end-user personnel as required.
- Reviewing and approving Service Provider test plans, procedures, and test results.
- Assisting in resolving any conflicts that may arise between the Service Provider and a MEVA end-user organization during installation, testing, and cutover to service and during follow-on operations.
- Assisting in resolving conflicts and disputes arising between the Service Provider and the MEVA States/Territories/Organizations. Conflicts and disputes must first be brought to the attention of the MEVA TMG for resolution and mediation. If the TMG is unable to resolve or mediate a solution to the dispute, the matter shall then be referred to the ICAO/NACC office for resolution.

TOC - Technical Operations Center. The physical space from which the MEVA II network is managed, monitored and supervised. The TOC coordinates network troubles, provides problem management and router configuration services, manages network changes, allocates and manages domain names and IP addresses, monitors routers, switches, hubs and UPS systems that keep the network operating smoothly, manages the distribution and updating of software and coordinates with affiliated networks.

Triangulation - A process by which the location of a radio transmitter can be determined by measuring either the radial distance or the direction of the received signal from two or three different points.

TT - Traffic Terminal. A Linkway 2100 that has been configured as a traffic terminal.

UPS - Uninterruptible Power Supply. A power supply that includes a battery to maintain power in the event of a power outage. Typically, a UPS keeps a computer running for several minutes after a power outage, enabling you to save data that is in RAM and shut down the computer gradually. Many UPSs now offer a software component that enables you to automate backup and shut down procedures in case there's a power failure while you're away from the computer. There are two basic types of UPS systems:

- Standby Power Systems (SPSs) and on-line UPS systems. An SPS monitors the power line and switches to battery power as soon as it detects a problem. The switch to battery, however, can require several milliseconds, during which time the computer is not receiving any power. Standby Power Systems are sometimes called Line-interactive UPSes.
- An on-line UPS avoids momentary power lapses by constantly providing power from its own inverter, even when the power line is functioning properly. In general, on-line UPSs are much more expensive than SPSs.

UW - Unique Word. A data pattern that aids receiving modems in locating the first symbol of the first channel in the data field. The UW consists of 48 consecutive symbols. Reference bursts have a UW that differs from non-reference bursts.

VDC - Volts of Direct Current. Care must be taken not to connect DC devices (such as DC electrical motors) to alternating current (AC) sources, as DC devices can be seriously damaged by doing so. The voltage itself is also important, as a device must never be connected to a power supply generating a higher voltage than the device is rated to handle.

VoIP - Voice Over Internet Protocol. A category of hardware and software that enables people to use the Internet as the transmission medium for telephone calls by sending voice data in packets using IP rather than by traditional circuit transmissions of the PSTN (Public Switched Telephone Network). See also *PSTN*.

VSAT - Very Small Aperture Terminal. An earthbound station used in satellite communications of data, voice and video signals, excluding broadcast television. A VSAT mostly uses the Prodelin 3.8M C-band. The main components of the VSAT satellite antenna are:

- Parabolic reflector
- Co-Pol (polarization) feed
- Feed support arm
- Azimuth and elevation adjustment

The satellite sends and receives signals from a ground station computer that acts as a hub for the system. Each end user is interconnected with the hub station via the satellite, forming a star topology. The hub controls the entire operation of the network. For one end user to communicate with another, each transmission has to first go to the hub station that then retransmits it via the satellite to the other end user's VSAT. VSAT can handle up to 56 Kbps. See also *Star Topology*.

Applicable Documents

For more information about the information described in the MEVA II Basic Training course, refer to the following documents.

Equipment Manuals

Linkway 2100 Technical Manual

Memotec 960e Technical Manual

Terrasat BUC Technical Manual

AST 3100 Monitor and Control (M&C) Device Data Sheet

Safety Manuals

SES Americom procedure A20.3-1 Injury and Illness Prevention Program

SES Americom procedure A20.3-2 RF Radiation Safety Program

SES Americom procedure A20.3-3 RF Hazard Communication Program

SES Americom procedure A20.3-4 Energy Control (Lockout) Program

SES Americom Pulse Environmental, Health & Safety Audit Questionnaire and Instructions

Other Documents

Technical Management Group Document of Agreement (DOA) Annex I

APENDICE/APPENDIX B

**PUNTOS FOCALES PARA COORDINAR LA IMPLEMENTACIÓN DEL PLAN DE ACCIÓN
INTERCONEXIÓN MEVA II/REDDIG**

**FOCAL POINT FOR COORDINATING THE IMPLEMENTATION OF THE ACTION PLAN
MEVA II/REDDIG INTERCONNECTION**

ESTADO ORG./ STATE ORG.	NOMBRE-TITULO/ NAME-TITLE	DATOS DE CONTACTO/ CONTACT INFORMATION
BRASIL	Athayde Licerio Viera Frauche	Tlf 21 21016665 Fax: 21 21016209 Email tel1@4decea.gov.br
COLOMBIA	Grupo de proyectos Internacionales Sr Edgar Clavijo	Unidad Administrativa Especial de Aeronáutica Civil - UAEAC Dirección Telecomunicaciones Aeropuerto Internacional El Dorado Tel.: (571) 266-3672 Fax: (571) 222-3486
ECUADOR	Asuntos técnicos:/Technical matter Sr. Raúl Avellán Oña Asuntos administrativos /Administrative matter : Sr. Víctor Acosta Caizapanta	Aeropuerto José Joaquín Olmedo Guayaquil, Ecuador Tel.: (59342) 692829 Cel.: (59384) 362441 REDDIG: 2308 / 2309 Dirección General Aviación Civil Quito, Ecuador Tel.: (5982) 2567822 Cel.: (5939) 9664148 Mail: victor_acosta@dgac.gov.ec
PERÚ	Sr José Luis Paredes Dávila	CORPAC S.A. Tel.: (511) 708 1196 Cel.: (511) 9582 5997 Mail: jlparedes@corpac.gob.pe
VENEZUELA	Sr Jorge Magallanes Coordinador Telecomunica- ciones/Telecommunica- tion Coordinator	Instituto Nacional de Aeronáutica Civil Coordinador de Telecomunicaciones Caracas, Venezuela Tel.: (58212) 277-4403 Mail: j.magallanes@inac.gov.ve
COCESNA	Sr. Roger Perez Gerente Estación Honduras /Honduras General Manager	COCESNA Tel. + 504 234 3360 ext. 1465 Fax + 504 234 3682 E-mail rperez@cocesna.org

APENDICE / APPENDIX C
UPDATED ACTION PLAN FOR IMPLEMENTATION OF MEVA II AND REDDIG INTERCONNECTIONS
PLAN DE ACCIÓN ACTUALIZADO PARA LA IMPLANTACIÓN DE LAS INTERCONEXIONES MEVA II Y REDDIG

Date/Fecha: April/Abril2008

Item No.	Action / Acción	Responsible / Responsable	Completion Date / Fecha de Finalización	Status- Encountered Difficulties / Estado-Dificultades encontradas
1	2	3	4	5
1	RFP Completion/Finalización del RFP	COCESNA	30-Apr-07	Completed / Finalizado
2	Required connections: / Conexiones requeridas: Aruba COCESNA Ecuador Colombia Peru Venezuela Brazil / Brasil Panama United States / Estados Unidos Jamaica Curacao / Curazao	MEVA II Service Provider and REDDIG Administration / Proveedor Servicio MEVA II y Administración REDDIG	30-Apr-07 / 30-Abr-07	Completed / Finalizado
3	Identification of Current Equipment / Identificación de Equipo Actual	MEVA II Service Provider and REDDIG Administration / Proveedor Servicio MEVA II y Administración REDDIG	28 Sep-07	Completed / Finalizado
4	Completion of SLA / Finalización de SLA	MEVA II Service Provider and REDDIG Administrator / Proveedor Servicio MEVA II y Administración REDDIG	30 Nov07	
5	Review of RFP / Revisión de RFP	MEVA II and REDDIG Members / Miembros MEVA II y REDDIG	29 June -07/ 29 Junio 07	The RFP was reviewed and approved by all MEVA II / REDDIG Member Administrations. / El RFP fue revisado y aprobado por todas las Administraciones miembros de las redes MEVA II y REDDIG.

Item No.	Action / Acción		Responsible / Responsable	Completion Date / Fecha de Finalización	Status- Encountered Difficulties / Estado-Dificultades encontradas
1	2		3	4	5
6	Proposals response / Respuesta de propuestas		MEVA II Service Provider and REDDIG Administration / Proveedor Servicio MEVA II y Administración REDDIG	26 Sep.-07	The response for the RFP from the MEVA II Service Provider and REDDIG Administration was presented at the MR/5 Meeting/ Las respuestas al RFP por parte del Proveedor de Servicio MEVA II y la Administración de la REDDIG se presentó en la Reunión MR/5.
7	Proposals review / Revisión de propuestas		Coordination meeting / Reunión de coordinación	5 Oct.-07	The proposal was reviewed in the MR/5 Meeting. / La propuesta se revisó en la Reunión MR/5
8	Focal Point nomination / Nombramiento Punto Focal	Send a letter to MEVA II / REDDIG Member Administrations / Envío carta a las Administraciones miembros de las redes MEVA II y REDDIG.	ICAO Regional Offices / Oficinas Regionales OACI	15 Oct. 07	The ICAO Regional Offices sent to the States/Organization involved in the MEVAII REDDIG interconnection a letter in order to nominate focal points. Las oficinas regionales de la OACI enviaron una carta invitando los Estados/Organización involucrados en la interconexión la nominación de puntos focales .
		Focal point designation/ Designación punto focal	MEVA II and REDDIG Members involved / Miembros de MEVA II y REDDIG involucrados	30-Oct-07	All the States/Organization members of MEVA II and REDDIG network involved in the interconnection nominated focal points. Todos los Estados/Organización miembros de la REDDIG y MEVA II involucrados en la interconexión nominaron puntos focales

Item No.	Action / Acción	Responsible / Responsable	Completion Date / Fecha de Finalización	Status- Encountered Difficulties / Estado-Dificultades encontradas
1	2	3	4	5
9	Application of MoU reviewed / Aplicación del MoU revisado	MEVA II / REDDIG Member Administrations / Administraciones miembros de las redes MEVA II y REDDIG	30-Oct-07	The ICAO Regional Offices sent to the States/Organization of MEVA II and REDDIG network in order to sign the MoU reviewed.
10	Review and acceptance of equipment costs for the MEVA II / REDDIG interconnection by the REDDIG Member Administrations / Revisión y aceptación por parte de las Administraciones Miembros de la REDDIG sobre costo de equipamiento para la interconexión MEVA II / REDDIG	All the REDDIG Member States / Todos Estados miembros de REDDIG	30 Oct-07	No comments were received No se recibieron comentarios al respecto
11	Review and acceptance of equipment costs for the MEVA II / REDDIG interconnection by the MEVA II Member Administrations involved / Revisión y aceptación por parte de las Administraciones Miembros de la MEVA II involucradas sobre costo de equipamiento para la interconexión MEVA II / REDDIG	Aruba, Curaçao, Jamaica, Panama, USA (Miami and Puerto Rico) and COCESNA / Aruba, Curaçao, Jamaica Panamá, USA (Miami y Puerto Rico) y COCESNA	30 Oct -07	No comments were received No se recibieron comentarios al respecto
12	Review and acceptance of proposed recurrent costs for the MEVA II / REDDIG interconnection/ Revisión y aprobación costos recurrentes propuestos para la interconexión MEVA II REDDIG	MEVA II/ REDDIG Member Administrations involved / Administraciones Miembros de la MEVA II y REDDIG involucradas	30 Oct- 07	No comments were received No se recibieron comentarios al respecto
13	Revised MoU Signature / Firma del MoU Revisado	MEVA II and REDDIG Members / Miembros MEVA II y REDDIG	30 Nov 07	The following States sent the MoU reviewed signed/Los siguientes Estados enviaron el MoU revisado firmado: Argentina, Brasil, Chile, Cuba, COCESNA, Estados Unidos, Guyana, Peru y/and Uruguay

Item No.	Action / Acción	Responsible / Responsable	Completion Date / Fecha de Finalización	Status- Encountered Difficulties / Estado-Dificultades encontradas
1	2	3	4	5
14	Review, approval and signing of contracts or contract amendments to carry out the MEVA II / REDDIG interconnection presented by the MEVA II Service Provider / Revisión, aprobación y firma de los contratos o enmienda de los mismos para llevar a cabo la interconexión MEVA II/REDDIG presentada a través del Proveedor de Servicio de la MEVA II	MEVA II Member Administrations involved and REDDIG Administration / Administraciones Miembros de la MEVA II involucradas y Administración REDDIG	30 Nov 07 /April 2008	<p>The REDDIG members assigned REDDIG Administration the revision and signature of AGS contract. The ICAO Technical Cooperation after reviewed the AGS contract considered the necessity to separate the no recurrent and recurrent costs. The decision took long time from December 2007 to April 2008 For the no recurrent cost a bid it is necessary and the ICAO Technical Cooperation a bid process will make. For the recurrent cost they ask AGS to modify the contract in order to include only the no recurrent cost.</p> <p>Los miembros de la REDDIG asignaron a la Administración de la REDDIG la revisión y firma del contrato. La Cooperación Técnica de la OACI después de revisar el contrato de AGS consideró la necesidad de separar los costos recurrentes de los no recurrentes. La decisión fue tomada después de un largo periodo de diciembre de 2007 a abril de 2008 Para los costos recurrentes se procederá a un proceso de licitación pública y para los costos recurrentes se consideró que AGS modificara el contrato de forma tal que incluyera solamente los costos recurrentes.</p>

Item No.	Action / Acción	Responsible / Responsable	Completion Date / Fecha de Finalización	Status- Encountered Difficulties / Estado-Dificultades encontradas
1	2	3	4	5
15	To ensure that all MEVA II and REDDIG nodes work with IS-IR Satellite, using Band C transponder with US/Latin America hemispheric beam and Co-Linear Vertical polarization / Asegurar que todos los nodos de la MEVA II y REDDIG operen en el satélite IS-1R, empleando transpondedores de banda C con haz hemisférico US/Latin America y polarización co-lineal vertical.	MEVA II Service Provider and REDDIG Administration/ Proveedor Servicio MEVA II/Administración REDDIG	30 Nov 07 April 08/ Abril 08	No change of polarity was executed ,AGS is waiting the decision of the approval of the interconnection. No se ha efectuado todavía el cambio de polaridad , AGS esta esperando la aprobación de la interconexión.
16	Equipment and spare parts acquisition for MEVA II/REDDIG interconnection/ Adquisición de equipamiento y repuestos para la interconexión MEVA II / REDDIG.	REDDIG Administration and MEVA II involved Member Administrations / Administración de la REDDIG y Administraciones Miembros de la MEVA II involucradas	14 Dec 07/14 Dic 07 End of June 08/Fin de junio 08	The ICAO Technical Cooperation informed that the bid process for the acquisition of equipments through a bid process will take a duration of approximately two months. La Cooperación Técnica de la OACI informó que el proceso de licitación para la adquisición de los equipos durara dos meses aproximadamente.
17	Site survey/ Inspección sitio	MEVA II Service Provider and REDDIG Administration / Proveedor MEVA II y Administración REDDIG	15 Jan 08/15 Ene 08 End of July 08/Fin de Julio 08	
18	Site preparation for equipment installation for MEVA II / REDDIG interconnection / Preparación de los sitios para albergar equipamiento para la interconexión MEVA II / REDDIG	Colombia, Venezuela and/y COCESNA	30 Jan 08/30 Ene 08 Aug08/Ago08	
19	Delivery of purchased equipment at the required sites. / Entrega de equipamiento adquirido en los sitios requeridos	MEVA II Service Provider and REDDIG Administration / Proveedor de Servicio MEVA II y Administración REDDIG	15 Feb 08 Sep08	

Item No.	Action / Acción	Responsible / Responsable	Completion Date / Fecha de Finalización	Status- Encountered Difficulties / Estado-Dificultades encontradas
1	2	3	4	5
20	Equipment installation / Instalación equipamiento	MEVA II Service Provider and REDDIG Administration / Proveedor de Servicio MEVA II y Administración REDDIG	14 Mar 08 Oct08	
21	Satellite line-up, configuration of site equipment and NCC for the interconnection/ Line-up satelital, configuración equipamiento en sitio y NCC para interconexión	MEVA II Service Provider and REDDIG Administration / Proveedor de Servicio MEVA II y Administración REDDIG	21 Mar 08 Oct08	
22	End-to-end trials for voice and data circuits / Pruebas de extremos a extremos para los circuitos de voz y datos	MEVAII Service Provider and REDDIG Administration / Proveedor de Servicio MEVA II y Administración REDDIG	27 Mar 08 Nov 08	
23	System Performance Evaluation / Evaluación de la performance del sistema	MEVA II Service Provider and REDDIG Administration / Proveedor de Servicio MEVA II y Administración REDDIG	25 Apr 08/25 Abr 08 Dec08/Dic08	
24	Service acceptance / Aceptación de los servicios /	MEVA II / REDDIG Member Administrations / Administraciones miembros de las redes MEVA II y REDDIG	30 Apr 08/30 Abr 08 Jan09/Ene09	
25	MEVA II / REDDIG Interconnection Implementation / Implantación de la interconexión MEVA II / REDDIG	MEVA II / REDDIG Member Administrations, MEVA II Service Provider and REDDIG Administrator / Administraciones miembros de las redes MEVA II y REDDIG, Proveedor Servicio MEVA II y Administración REDDIG	May 08/ Mayo 08 Feb09	

Legend / Leyenda:

MoU: Memorandum of Understanding / Memorando de Entendimiento

RFP: Request for Tecnical and Econmic Proposal / Solicitud de Propuestas Técnicas y Económicas

SLA: Service Level Agreement / Acuerdo de Nivel de Servicio

D-1

APPENDIX D**FOLLOW-UP OF VALID CONCLUSIONS FROM PREVIOUS MEVA REDDIG COORDINATION MEETINGS**

Number	Title	Actions done	Status
MR 5/1	Review of the response from the MEVA II service provider to the MEVA II/ REDDIG RFP	The MEVA II Service Provider was issued the requested Revision; however there are still some inquiries to be answered by the MEVA II Service Provider. It is expected to have these answers during the Meeting.	Finalized
MR 5/2	Establishment of a coordinated satellite contingency for the MEVA II and REDDIG vsat networks	This topic will be discussed on agenda item 2.	Valid
MR 5/3	Adoption of the revised MoU for the MEVA II/ REDDIG interconnection	The revised MoU was sent to the members of both networks and confirmation was received of several of them.	Finalized
MR 5/4	Adoption of the updated action plan for the MEVA II/ REDDIG interconnection implementation	The referred Action Plan will be subject of review on agenda item 1 and it will be updated by the Meeting.	Replaced
MR 5/5	Request for a contract proposal between the MEVA II service provider and the REDDIG administration	The contract proposal was submitted and it is in the process of signing of the respective hiring.	Finalized