

Operations & Performance



Paul Giesman Friction Task Force – Annex 6/8 Subgroup
14/15 August 201



Effect of Runway Condition on Aircraft Performance



Effects in Performance Models

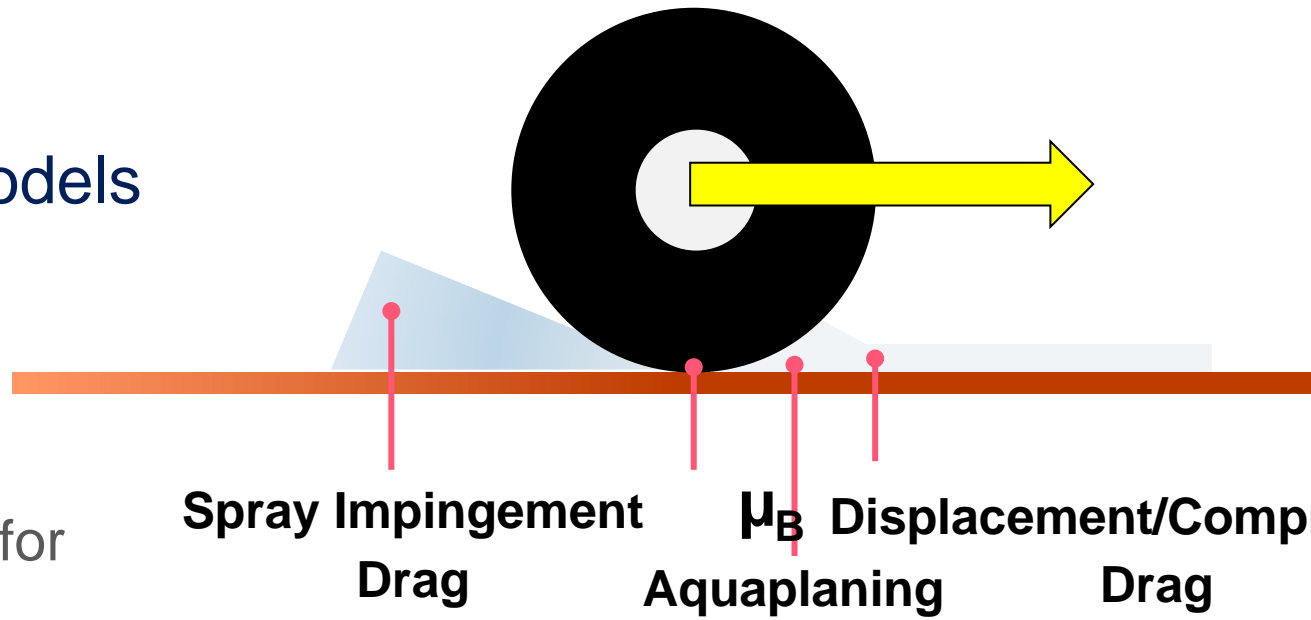

Braking Performance accounts for

Spray Impingement Drag **μ_B Aquaplaning** **Displacement/Compression Drag**

Effect	Dry/Wet	Hard Contaminants	Fluid Contaminants
Effective wheel to ground friction	Yes	Yes	Yes
Displacement Drag	-	-	Yes
Compression Drag	-	-	Yes
Impingement Drag	-	-	Yes
Aquaplaning	-	-	Yes

Current Regulatory Dispatch Requirements



IR-OPS CAT.POL. A.230(a)(1)

FAR 121.195

$RLD_{dry} = ALD / 0.6$



IR-OPS CAT.POL. A.235(a)(2)

FAR 121.195

$RLD_{wet} = 1.15 \times RLD_{dry}$

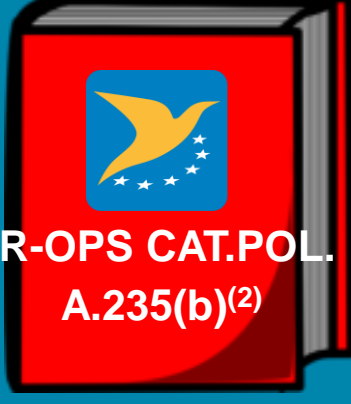

IR-OPS CAT.POL. A.235(b)(2)

Max of $\left\{ \begin{array}{l} RLD_{conta} = \\ 1.15 \times ALD_{contam} \\ RLD_{wet} \end{array} \right.$

RLD shorter than Landing Distance Available (LDA)



EASA Dispatch Requirements for contaminated runways



- Under EASA regulation CS25.1591 manufacturers may publish takeoff and landing performance for contaminated runways
- Associated AMC provides friction models for various contaminants

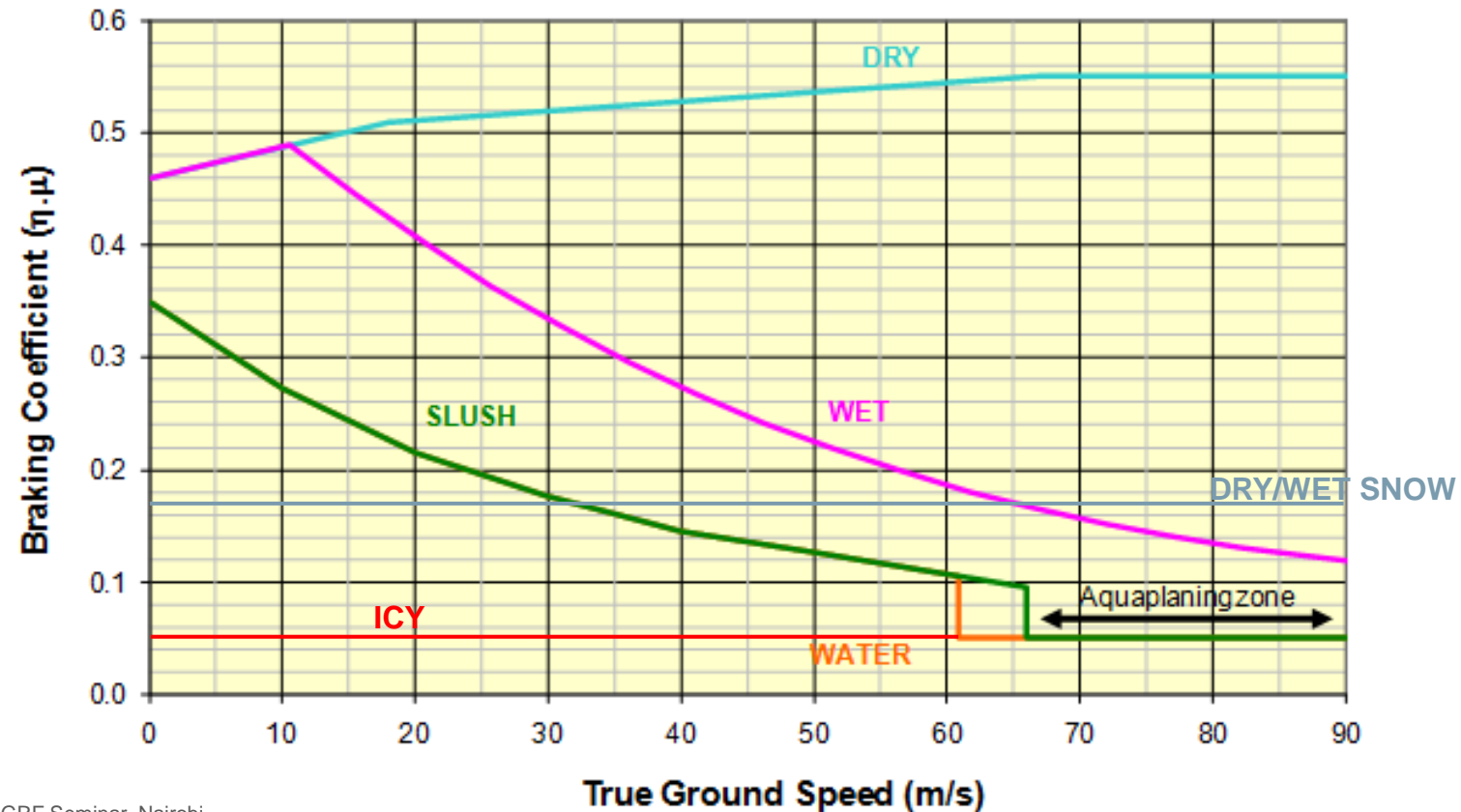

Current Regulatory In-Flight Requirements



The flight crew must check that a safe landing can be performed in the expected conditions

(1) Former EU-OPS 1.400

Accident Statistics

10 year moving average hull loss rate by accident category per million flights

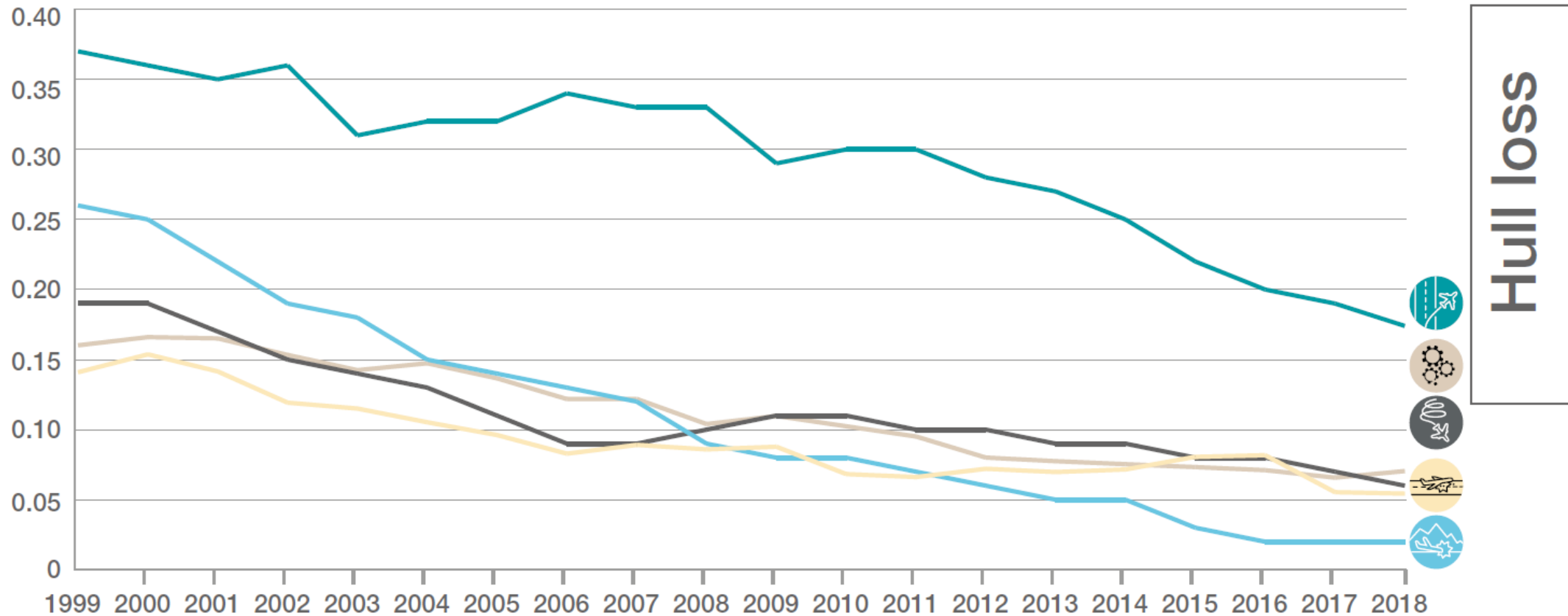

Situation of the Industry Today

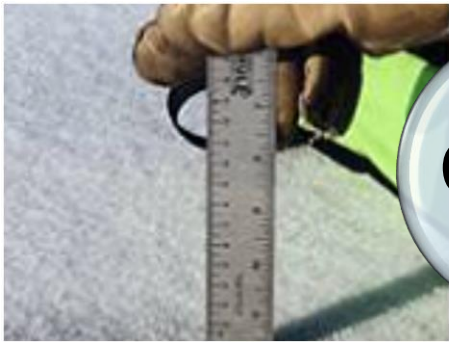

Contaminant

Different terminology

Different contaminant types

Insufficient depth accuracy



Friction

No correlation with A/C performance

Not up to date



PIREP

Not objective



Perfo.



Def.



Proc.

Reporting NOT Performance-Relevant



ICAO Friction Task Force Jobcard

PART I				
Category	Safety	Sustainability	Implementation	Reference: AP001
Title	Assessment and reporting of runway surface conditions			
Proposed by	Secretariat/WG-PDP			
Problem Statement	Runway surface conditions have contributed to many safety events and investigations have revealed shortfalls in the accuracy and timeliness of assessment and reporting methods currently provided for in ICAO provisions and guidance material			
Specific Details (including impact statements)	While techniques for the measurement of runway friction provide useful information for runway surface friction maintenance purposes, they are not suitable in all weather conditions when the runway is contaminated and the information when used in reports could be misleading to pilots. Reports used by pilots need to be performance of the runway for both airport operations and use it effectively.			

...need reports that are directly related to the performance of the aircraft.

Runway surface conditions have contributed to many safety events and investigations have revealed shortfalls in the accuracy and timeliness of assessment and reporting methods currently provided for in ICAO provisions and guidance material

Runway surface conditions have contributed to many safety events and investigations have revealed shortfalls in the accuracy and timeliness of assessment and reporting methods currently provided for in ICAO provisions and guidance material

Rationale for acceptance/rejection				
Action already in progress	Current work programme			
Interdependencies/References	AN-WP/8571.PD			
Required Action				
1	Develop provisions for the reporting of runway surface conditions	AP/PASG	Proposed amendments to Annex 14 Volume 1 and other related Annexes Proposed amendments to PANS-Aerodromes and PANS-ATM	Q2/2014 Q2/2015
2	Develop guidance material for the assessment of runway surface conditions, including friction level and where contamination exists	AP/PASG	Proposed amendments to PANS-Aerodromes Proposed amendments to Doc 9137	Q2/2015 Q1/2016
3	Develop guidance material for the measurement and maintenance of runway friction	AP/PASG	Proposed amendments to PANS-Aerodromes Proposed amendments to Doc 9137	Q2/2015 Q1/2016



End to End System



Aerodromes

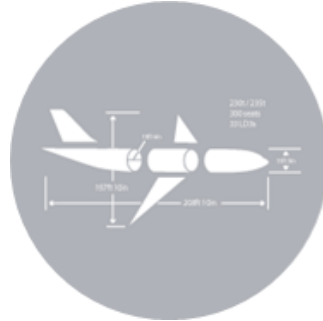

Manufacturers



Operators

Common Language

Contaminant Types

Runway Condition Codes

Direct Input to Performance Assessment

Performance Relevance

Depth Thresholds & Temperatures

Significant Changes

Airworthiness – Annex 8

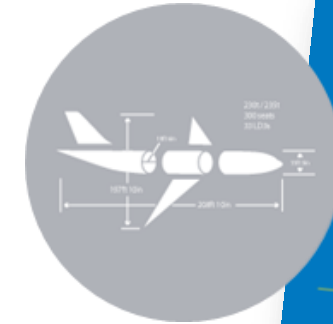

- Option for takeoff performance on contaminated runway
- Mandate split of landing performance information into
 - At Time of Takeoff data (dispatch)
 - At Time of Landing data (in-flight)
- New At Time of Landing Distances shall reflect real operating practices
- Both types of landing distances may be provided for contaminated runways



Operations - Annex 6



- For large and small airplanes
- Mandate AIREP when conditions worse than reported
- Mandate in-flight check with appropriate margin before starting approach

Aeroplane Performance Manual

- Introduction to Operations on Contaminated Runways
- 4 Flight-Phase oriented Chapters
 - Take-off
 - En-Route
 - Landing
 - Missed Approach
- **Clear Focus on GRF**
- Other information considered as non-controversial
- Based on existing national guidance and practices
- Still under Review by Ops Section

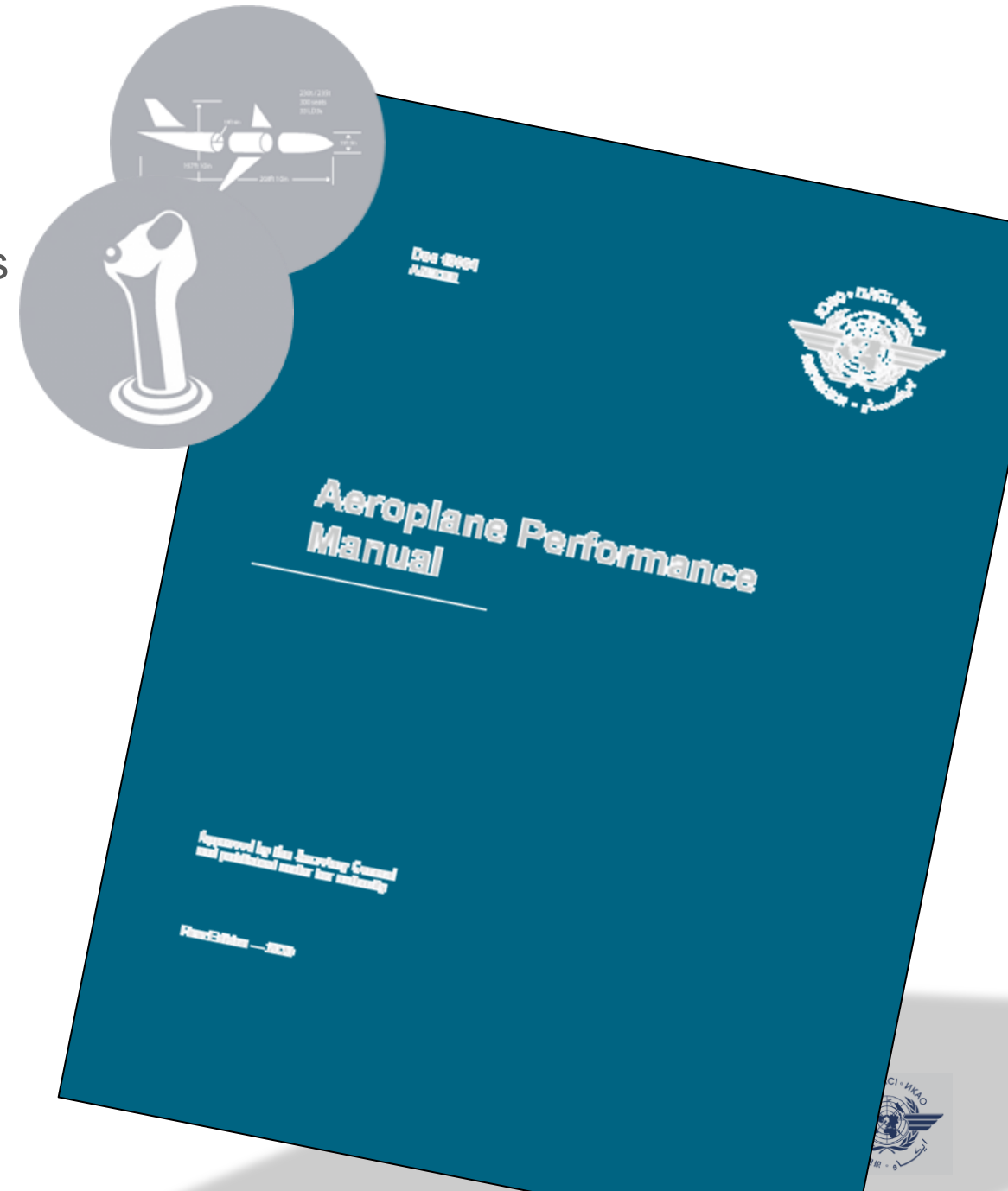

Guidance for Manufacturers

- Publish Operational Landing Distances
 - “Minimum” Compliance with principles
 - Cover all 6 friction levels
 - Introduce Accountability for
 - Temperature effect
 - Runway slope effect
 - Approach speed increment effect

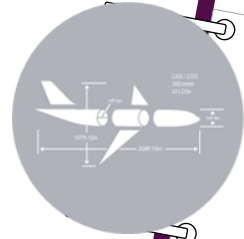

AIRBUS
OPERATIONS MANUAL

IN FLIGHT PERFORMANCE

1/4

25 JAN 11

LANDING DISTANCE - DRY

The Reference Distance (RDP DCT) considers: Sea Level (SL), ISA, no wind, no slope, no engine reverse
Thrust, manual landing, VAPP/LO without APPR COR.

CONF 1

Conditions as Landing Distance (m)

Braking Mode	RDP DCT (m) for 150m	WEIGHT		SPD	ALT	WIND	TEMP	SLOPE	REV
		For 15T BELOW 150m	For 15T ABOVE 150m						
Maximum MANUAL	1 750	-30	+140	+70	For 1000m above SL	For 5kt	For 10°C ABOVE ISA	For 1% Down Slope	For Thrust Reverse Operative
AUTOGRAZE MED	1 850	-30	+140	+70	For 1000m above SL	For 5kt	For 10°C ABOVE ISA	For 1% Down Slope	For Thrust Reverse Operative
AUTOGRAZE LOW	2 250	-30	+140	+70	For 1000m above SL	For 5kt	For 10°C ABOVE ISA	For 1% Down Slope	For Thrust Reverse Operative
Overweight Ldg prog	= 180 m								
Autoland	= 230 m								

CONF 2

Conditions as Landing Distance (m)

Braking Mode	RDP DCT (m) for 150m	WEIGHT		SPD	ALT	WIND	TEMP	SLOPE	REV
		For 15T BELOW 150m	For 15T ABOVE 150m						
Maximum MANUAL	1 750	-30	+140	+70	For 1000m above SL	For 5kt	For 10°C ABOVE ISA	For 1% Down Slope	For Thrust Reverse Operative
AUTOGRAZE MED	1 850	-30	+140	+70	For 1000m above SL	For 5kt	For 10°C ABOVE ISA	For 1% Down Slope	For Thrust Reverse Operative
AUTOGRAZE LOW	2 250	-30	+140	+70	For 1000m above SL	For 5kt	For 10°C ABOVE ISA	For 1% Down Slope	For Thrust Reverse Operative
Overweight Ldg prog	= 180 m								
Autoland	= 230 m								

CONF 3

Conditions as Landing Distance (m)

Braking Mode	RDP DCT (m) for 150m	WEIGHT		SPD	ALT	WIND	TEMP	SLOPE	REV
		For 15T BELOW 150m	For 15T ABOVE 150m						
Maximum MANUAL	1 750	-30	+140	+70	For 1000m above SL	For 5kt	For 10°C ABOVE ISA	For 1% Down Slope	For Thrust Reverse Operative
AUTOGRAZE MED	1 850	-30	+140	+70	For 1000m above SL	For 5kt	For 10°C ABOVE ISA	For 1% Down Slope	For Thrust Reverse Operative
AUTOGRAZE LOW	2 250	-30	+140	+70	For 1000m above SL	For 5kt	For 10°C ABOVE ISA	For 1% Down Slope	For Thrust Reverse Operative
Overweight Ldg prog	= 180 m								
Autoland	= 230 m								

LANDING DISTANCE - GOOD

The Reference Distance (RDP DCT) considers: Sea Level (SL), ISA, no wind, no slope, no engine reverse
Thrust, manual landing, VAPP/LO without APPR COR.

CONF 1

Conditions as Landing Distance (m)

Braking Mode	RDP DCT (m) for 150m	WEIGHT		SPD	ALT	WIND	TEMP	SLOPE	REV
		For 15T BELOW 150m	For 15T ABOVE 150m						
Maximum MANUAL	1 750	-30	+140	+70	For 1000m above SL	For 5kt	For 10°C ABOVE ISA	For 1% Down Slope	For Thrust Reverse Operative
AUTOGRAZE MED	1 850	-30	+140	+70	For 1000m above SL	For 5kt	For 10°C ABOVE ISA	For 1% Down Slope	For Thrust Reverse Operative
AUTOGRAZE LOW	2 250	-30	+140	+70	For 1000m above SL	For 5kt	For 10°C ABOVE ISA	For 1% Down Slope	For Thrust Reverse Operative
Overweight Ldg prog	= 180 m								
Autoland	= 230 m								

CONF 2

Conditions as Landing Distance (m)

Braking Mode	RDP DCT (m) for 150m	WEIGHT		SPD	ALT	WIND	TEMP	SLOPE	REV
		For 15T BELOW 150m	For 15T ABOVE 150m						
Maximum MANUAL	1 750	-30	+140	+70	For 1000m above SL	For 5kt	For 10°C ABOVE ISA	For 1% Down Slope	For Thrust Reverse Operative
AUTOGRAZE MED	1 850	-30	+140	+70	For 1000m above SL	For 5kt	For 10°C ABOVE ISA	For 1% Down Slope	For Thrust Reverse Operative
AUTOGRAZE LOW	2 250	-30	+140	+70	For 1000m above SL	For 5kt	For 10°C ABOVE ISA	For 1% Down Slope	For Thrust Reverse Operative
Overweight Ldg prog	= 180 m								
Autoland	= 230 m								

CONF 3

Conditions as Landing Distance (m)

Braking Mode	RDP DCT (m) for 150m	WEIGHT		SPD	ALT	WIND	TEMP	SLOPE	REV
		For 15T BELOW 150m	For 15T ABOVE 150m						
Maximum MANUAL	1 750	-30	+140	+70	For 1000m above SL	For 5kt	For 10°C ABOVE ISA	For 1% Down Slope	For Thrust Reverse Operative
AUTOGRAZE MED	1 850	-30	+140	+70	For 1000m above SL	For 5kt	For 10°C ABOVE ISA	For 1% Down Slope	For Thrust Reverse Operative
AUTOGRAZE LOW	2 250	-30	+140	+70	For 1000m above SL	For 5kt	For 10°C ABOVE ISA	For 1% Down Slope	For Thrust Reverse Operative
Overweight Ldg prog	= 180 m								
Autoland	= 230 m								

OPS DATA

OEB

ICAO - IATA

Chapter on Operations On Contaminated Runways

- Description of the RCR for Operators and Pilots
- Introduction to the Assessment Process applied by the Aerodrome
- Description and use of the RCAM and RWYCC
- Considerations for making AIREPs of Braking Action
- Training Syllabus



Chapter on Landing

- Derivation of Landing Performance Data for Time of Arrival
- Publication of Data and Limitations
- Fallback Generic Factors in case no Data is provided by the Manufacturer
- Regulatory background
- Considerations for Performance Assessment in Approach Preparation
- Considerations for Flight Crew
- Pilot Procedures for Landing on Length-Limited Runways

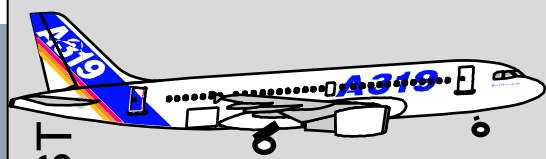

NO MARGIN

ACTUAL LDG DIST

DRY
WET
WATER
SLUSH
SNOW
ICE



ISA



IN-FLIGHT LDG DIST

15% MARGIN



Code	Weather Conditions Description	Observation and Developmental Characteristics	Decision Making Level
6	Dry		Dry
5	+ Rain in 10' layer + Fog + Ice + Snow	Wings free of ice for at least 100 ft before landing with 100 ft	Good
4	Wing + Rain in 10' layer + Fog + Ice + Snow	Wings free of ice for at least 100 ft before landing with 100 ft	Good to Medium
3	Wing + Rain in 10' layer + Fog + Ice + Snow	Wings free of ice for at least 100 ft before landing with 100 ft	Medium
2	Wing + Rain in 10' layer + Fog + Ice + Snow	Wings free of ice for at least 100 ft before landing with 100 ft	Medium to Poor
1	No wind at all		Poor
0	Wing + Rain in 10' layer + Fog + Ice + Snow	Wings free of ice for at least 100 ft before landing with 100 ft	Poor

DRY
GOOD
GOOD TO MEDIUM
MEDIUM
MEDIUM TO POOR
POOR



OAT

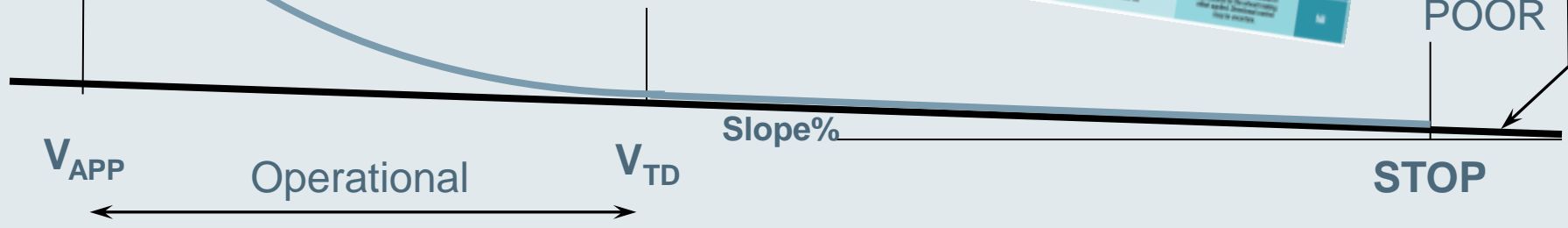

ICAO Doc 10064 Aeroplane Performance Manual

- Provides the **effective wheel to ground coefficient** for each **RWYCC**
- Not specific to an individual aeroplane
- Adaptable to the anti-skid system type
- Ensures harmonized **Landing Distances at Time for Arrival** between all types

RWYCC	Runway Surface Condition Description	Pilot-Reported Braking Action	Wheel Braking Coefficient
6	DRY	—	90 per cent of certified value used to comply with Annex 8 Part IIB 2.2.7 e) ¹ .
5	FROST WET (The runway surface is covered by any visible dampness or water up to and including 3mm deep.) SLUSH (up to and including 3mm depth) DRY SNOW (up to and including 3mm depth) WET SNOW (up to and including 3mm depth)	Good	Per method defined in Note 2 below.
4	COMPACTED SNOW (Outside air temperature minus 15 degrees Celsius or below)	Good to Medium	0.20 ³
3	WET (Slippery Wet) (except) DRY SNOW (more than 3mm depth) WET SNOW (more than 3mm depth) DRY SNOW ON TOP OF COMPACTED SNOW (Any depth) WET SNOW ON TOP OF COMPACTED SNOW (Any depth) COMPACTED SNOW (Outside air temperature above minus 15 degrees Celsius)	Medium	0.16 ³
2	STANDING WATER (more than 3mm depth) SLUSH (more than 3mm depth)	Medium to Poor	(1) For speeds below 85 per cent of the aquaplaning speed ³ ; 50 per cent of the wheel braking coefficient determined for RWYCC=5, but no greater than 0.16; and (2) For speeds at 85 per cent of the aquaplaning speed ⁴ and above: 0.05 ³ .
1	ICE	Poor	0.07 ³

ICAO Doc 10064 Aeroplane Performance Manual

- Provides the **effective wheel to ground coefficient** for each **RWYCC**
- Not specific to an individual aeroplane
- Adaptable to the anti-skid system type
- Ensures harmonized **Landing Distances at Time for Arrival** between all types
- Based on **existing** EASA guidance on contaminated runway friction from **historic** flight tests

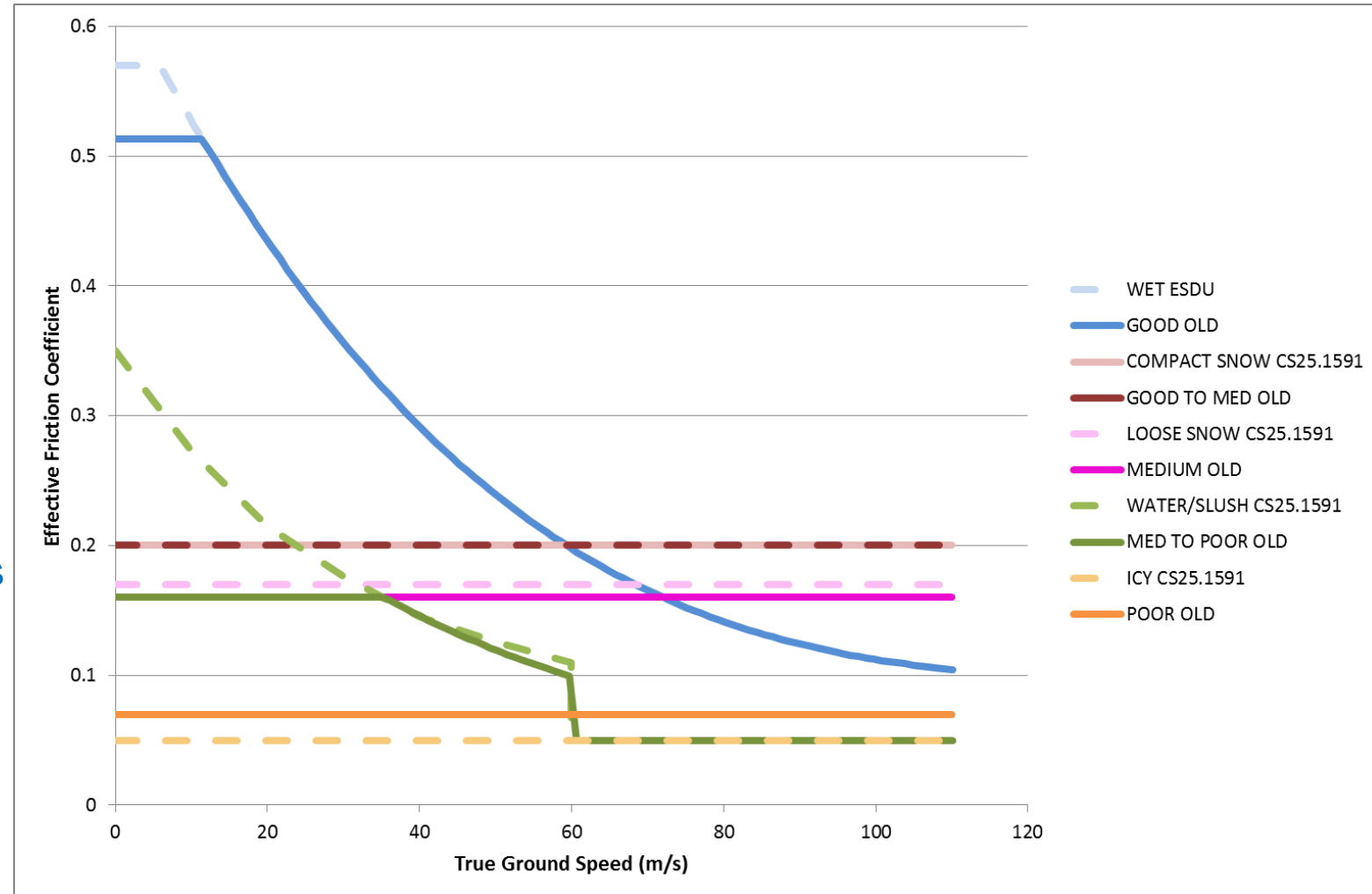

Runway Condition Code – Direct Input to Landing Distance

Computation

Runway condition code	6 - DRY	5 - GOOD	4 - GOOD TO MEDIUM	3 - MEDIUM	2 - MEDIUM TO POOR	1 - POOR																																																																													
6	<p>reverse thrust, manual landing⁽¹⁾, VAPP-VLS without APPR COR.</p> <p>3 - MEDIUM</p> <table border="1"> <thead> <tr> <th>Category</th> <th>LDG CONF</th> <th>REF DIST (ft) for 63T</th> <th>Per 1T above 63T</th> <th>Per 5kt</th> <th>Per 1000ft above SL</th> <th>Per 5kt TW</th> <th>Per 10°C above ISA</th> <th>Per 1% Down Slope</th> <th>Per Thrust Reverser Operative</th> <th>if QVV PROC applied</th> </tr> </thead> <tbody> <tr> <td>Maximum MANUAL</td> <td>FULL</td> <td>5 806</td> <td>+130</td> <td>+330</td> <td>+210</td> <td>+700</td> <td>+190</td> <td>+320</td> <td>-70</td> <td>+1 800</td> </tr> <tr> <td></td> <td>3</td> <td>6 206</td> <td>+140</td> <td>+280</td> <td>+240</td> <td>+740</td> <td>+220</td> <td>+370</td> <td>-130</td> <td>+2 400</td> </tr> <tr> <td>(MED)</td> <td>FULL</td> <td>5 850</td> <td>+120</td> <td>+350</td> <td>+220</td> <td>+710</td> <td>+190</td> <td>+330</td> <td>-110</td> <td>+1 730</td> </tr> <tr> <td></td> <td>3</td> <td>6 296</td> <td>+140</td> <td>+370</td> <td>+240</td> <td>+740</td> <td>+220</td> <td>+380</td> <td>-150</td> <td>+1 730</td> </tr> <tr> <td>AUTOBRAKE LOW</td> <td>FULL</td> <td>6 106</td> <td>+140</td> <td>+430</td> <td>+230</td> <td>+730</td> <td>+210</td> <td>+290</td> <td>-20</td> <td>+800</td> </tr> <tr> <td></td> <td>3</td> <td>6 736</td> <td>+150</td> <td>+480</td> <td>+250</td> <td>+760</td> <td>+230</td> <td>+340</td> <td>-80</td> <td>+800</td> </tr> </tbody> </table> <p>(1) Automatic Landing correction: if CONF FULL, add 60ft; if CONF 3, add 75ft. (2) Weight correction: if CONF FULL, subtract 50ft per 1T below 63T; if CONF 3, subtract 70ft per 1T below 63T.</p>						Category	LDG CONF	REF DIST (ft) for 63T	Per 1T above 63T	Per 5kt	Per 1000ft above SL	Per 5kt TW	Per 10°C above ISA	Per 1% Down Slope	Per Thrust Reverser Operative	if QVV PROC applied	Maximum MANUAL	FULL	5 806	+130	+330	+210	+700	+190	+320	-70	+1 800		3	6 206	+140	+280	+240	+740	+220	+370	-130	+2 400	(MED)	FULL	5 850	+120	+350	+220	+710	+190	+330	-110	+1 730		3	6 296	+140	+370	+240	+740	+220	+380	-150	+1 730	AUTOBRAKE LOW	FULL	6 106	+140	+430	+230	+730	+210	+290	-20	+800		3	6 736	+150	+480	+250	+760	+230	+340	-80	+800
Category	LDG CONF	REF DIST (ft) for 63T	Per 1T above 63T	Per 5kt	Per 1000ft above SL	Per 5kt TW	Per 10°C above ISA	Per 1% Down Slope	Per Thrust Reverser Operative	if QVV PROC applied																																																																									
Maximum MANUAL	FULL	5 806	+130	+330	+210	+700	+190	+320	-70	+1 800																																																																									
	3	6 206	+140	+280	+240	+740	+220	+370	-130	+2 400																																																																									
(MED)	FULL	5 850	+120	+350	+220	+710	+190	+330	-110	+1 730																																																																									
	3	6 296	+140	+370	+240	+740	+220	+380	-150	+1 730																																																																									
AUTOBRAKE LOW	FULL	6 106	+140	+430	+230	+730	+210	+290	-20	+800																																																																									
	3	6 736	+150	+480	+250	+760	+230	+340	-80	+800																																																																									
5	<p>3 - DRY</p> <table border="1"> <thead> <tr> <th>Category</th> <th>LDG CONF</th> <th>REF DIST (ft) for 63T</th> <th>Per 1T above 63T</th> <th>Per 5kt</th> <th>Per 1000ft above SL</th> <th>Per 5kt TW</th> <th>Per 10°C above ISA</th> <th>Per 1% Down Slope</th> <th>Per Thrust Reverser Operative</th> <th>if QVV PROC applied</th> </tr> </thead> <tbody> <tr> <td>Maximum MANUAL</td> <td>FULL</td> <td>3 290</td> <td>+120</td> <td>+220</td> <td>+110</td> <td>+340</td> <td>+100</td> <td>+60</td> <td>0</td> <td>+2 240</td> </tr> <tr> <td></td> <td>3</td> <td>3 570</td> <td>+150</td> <td>+220</td> <td>+120</td> <td>+370</td> <td>+110</td> <td>+60</td> <td>0</td> <td>+2 500</td> </tr> <tr> <td>AUTOBRAKE MED</td> <td>FULL</td> <td>4 120</td> <td>+90</td> <td>+290</td> <td>+140</td> <td>+410</td> <td>+130</td> <td>+30</td> <td>0</td> <td>+730</td> </tr> <tr> <td></td> <td>3</td> <td>4 470</td> <td>+100</td> <td>+300</td> <td>+150</td> <td>+430</td> <td>+130</td> <td>+30</td> <td>0</td> <td>+770</td> </tr> <tr> <td>AUTOBRAKE LOW</td> <td>FULL</td> <td>5 790</td> <td>+140</td> <td>+440</td> <td>+210</td> <td>+630</td> <td>+190</td> <td>+50</td> <td>0</td> <td>+800</td> </tr> <tr> <td></td> <td>3</td> <td>6 380</td> <td>+150</td> <td>+470</td> <td>+230</td> <td>+650</td> <td>+220</td> <td>+50</td> <td>0</td> <td>+800</td> </tr> </tbody> </table>						Category	LDG CONF	REF DIST (ft) for 63T	Per 1T above 63T	Per 5kt	Per 1000ft above SL	Per 5kt TW	Per 10°C above ISA	Per 1% Down Slope	Per Thrust Reverser Operative	if QVV PROC applied	Maximum MANUAL	FULL	3 290	+120	+220	+110	+340	+100	+60	0	+2 240		3	3 570	+150	+220	+120	+370	+110	+60	0	+2 500	AUTOBRAKE MED	FULL	4 120	+90	+290	+140	+410	+130	+30	0	+730		3	4 470	+100	+300	+150	+430	+130	+30	0	+770	AUTOBRAKE LOW	FULL	5 790	+140	+440	+210	+630	+190	+50	0	+800		3	6 380	+150	+470	+230	+650	+220	+50	0	+800
Category	LDG CONF	REF DIST (ft) for 63T	Per 1T above 63T	Per 5kt	Per 1000ft above SL	Per 5kt TW	Per 10°C above ISA	Per 1% Down Slope	Per Thrust Reverser Operative	if QVV PROC applied																																																																									
Maximum MANUAL	FULL	3 290	+120	+220	+110	+340	+100	+60	0	+2 240																																																																									
	3	3 570	+150	+220	+120	+370	+110	+60	0	+2 500																																																																									
AUTOBRAKE MED	FULL	4 120	+90	+290	+140	+410	+130	+30	0	+730																																																																									
	3	4 470	+100	+300	+150	+430	+130	+30	0	+770																																																																									
AUTOBRAKE LOW	FULL	5 790	+140	+440	+210	+630	+190	+50	0	+800																																																																									
	3	6 380	+150	+470	+230	+650	+220	+50	0	+800																																																																									
4	<p>4 - GOOD TO MEDIUM</p> <table border="1"> <thead> <tr> <th>Category</th> <th>LDG CONF</th> <th>REF DIST (ft) for 63T</th> <th>Per 1T above 63T</th> <th>Per 5kt</th> <th>Per 1000ft above SL</th> <th>Per 5kt TW</th> <th>Per 10°C above ISA</th> <th>Per 1% Down Slope</th> <th>Per Thrust Reverser Operative</th> <th>if QVV PROC applied</th> </tr> </thead> <tbody> <tr> <td>Maximum MANUAL</td> <td>FULL</td> <td>4 240</td> <td>+140</td> <td>+350</td> <td>+200</td> <td>+630</td> <td>+180</td> <td>+15</td> <td>0</td> <td>+800</td> </tr> <tr> <td></td> <td>3</td> <td>4 730</td> <td>+160</td> <td>+380</td> <td>+240</td> <td>+700</td> <td>+210</td> <td>+15</td> <td>0</td> <td>+800</td> </tr> </tbody> </table>						Category	LDG CONF	REF DIST (ft) for 63T	Per 1T above 63T	Per 5kt	Per 1000ft above SL	Per 5kt TW	Per 10°C above ISA	Per 1% Down Slope	Per Thrust Reverser Operative	if QVV PROC applied	Maximum MANUAL	FULL	4 240	+140	+350	+200	+630	+180	+15	0	+800		3	4 730	+160	+380	+240	+700	+210	+15	0	+800																																												
Category	LDG CONF	REF DIST (ft) for 63T	Per 1T above 63T	Per 5kt	Per 1000ft above SL	Per 5kt TW	Per 10°C above ISA	Per 1% Down Slope	Per Thrust Reverser Operative	if QVV PROC applied																																																																									
Maximum MANUAL	FULL	4 240	+140	+350	+200	+630	+180	+15	0	+800																																																																									
	3	4 730	+160	+380	+240	+700	+210	+15	0	+800																																																																									
3	<p>3 - MEDIUM</p> <table border="1"> <thead> <tr> <th>Category</th> <th>LDG CONF</th> <th>REF DIST (ft) for 63T</th> <th>Per 1T above 63T</th> <th>Per 5kt</th> <th>Per 1000ft above SL</th> <th>Per 5kt TW</th> <th>Per 10°C above ISA</th> <th>Per 1% Down Slope</th> <th>Per Thrust Reverser Operative</th> <th>if QVV PROC applied</th> </tr> </thead> <tbody> <tr> <td>Maximum MANUAL</td> <td>FULL</td> <td>5 540</td> <td>+130</td> <td>+330</td> <td>+210</td> <td>+630</td> <td>+190</td> <td>+20</td> <td>0</td> <td>+800</td> </tr> <tr> <td></td> <td>3</td> <td>5 690</td> <td>+110</td> <td>+320</td> <td>+190</td> <td>+600</td> <td>+170</td> <td>+20</td> <td>0</td> <td>+800</td> </tr> <tr> <td>AUTOBRAKE MED</td> <td>FULL</td> <td>5 630</td> <td>+120</td> <td>+340</td> <td>+210</td> <td>+630</td> <td>+190</td> <td>+20</td> <td>0</td> <td>+800</td> </tr> <tr> <td></td> <td>3</td> <td>5 830</td> <td>+140</td> <td>+440</td> <td>+210</td> <td>+660</td> <td>+190</td> <td>+170</td> <td>0</td> <td>+800</td> </tr> <tr> <td>AUTOBRAKE LOW</td> <td>FULL</td> <td>6 490</td> <td>+150</td> <td>+480</td> <td>+230</td> <td>+680</td> <td>+220</td> <td>+190</td> <td>0</td> <td>+800</td> </tr> <tr> <td></td> <td>3</td> <td>6 490</td> <td>+150</td> <td>+480</td> <td>+230</td> <td>+680</td> <td>+220</td> <td>+190</td> <td>0</td> <td>+800</td> </tr> </tbody> </table> <p>(1) Automatic Landing correction: if CONF FULL, add 60ft; if CONF 3, add 75ft. (2) Weight correction: if CONF FULL, subtract 50ft per 1T below 63T; if CONF 3, subtract 60ft per 1T below 63T.</p>						Category	LDG CONF	REF DIST (ft) for 63T	Per 1T above 63T	Per 5kt	Per 1000ft above SL	Per 5kt TW	Per 10°C above ISA	Per 1% Down Slope	Per Thrust Reverser Operative	if QVV PROC applied	Maximum MANUAL	FULL	5 540	+130	+330	+210	+630	+190	+20	0	+800		3	5 690	+110	+320	+190	+600	+170	+20	0	+800	AUTOBRAKE MED	FULL	5 630	+120	+340	+210	+630	+190	+20	0	+800		3	5 830	+140	+440	+210	+660	+190	+170	0	+800	AUTOBRAKE LOW	FULL	6 490	+150	+480	+230	+680	+220	+190	0	+800		3	6 490	+150	+480	+230	+680	+220	+190	0	+800
Category	LDG CONF	REF DIST (ft) for 63T	Per 1T above 63T	Per 5kt	Per 1000ft above SL	Per 5kt TW	Per 10°C above ISA	Per 1% Down Slope	Per Thrust Reverser Operative	if QVV PROC applied																																																																									
Maximum MANUAL	FULL	5 540	+130	+330	+210	+630	+190	+20	0	+800																																																																									
	3	5 690	+110	+320	+190	+600	+170	+20	0	+800																																																																									
AUTOBRAKE MED	FULL	5 630	+120	+340	+210	+630	+190	+20	0	+800																																																																									
	3	5 830	+140	+440	+210	+660	+190	+170	0	+800																																																																									
AUTOBRAKE LOW	FULL	6 490	+150	+480	+230	+680	+220	+190	0	+800																																																																									
	3	6 490	+150	+480	+230	+680	+220	+190	0	+800																																																																									
2	<p>4 - GOOD TO MEDIUM</p> <table border="1"> <thead> <tr> <th>Category</th> <th>LDG CONF</th> <th>REF DIST (ft) for 63T</th> <th>Per 1T above 63T</th> <th>Per 5kt</th> <th>Per 1000ft above SL</th> <th>Per 5kt TW</th> <th>Per 10°C above ISA</th> <th>Per 1% Down Slope</th> <th>Per Thrust Reverser Operative</th> <th>if QVV PROC applied</th> </tr> </thead> <tbody> <tr> <td>Maximum MANUAL</td> <td>FULL</td> <td>4 240</td> <td>+140</td> <td>+350</td> <td>+200</td> <td>+630</td> <td>+180</td> <td>+15</td> <td>0</td> <td>+800</td> </tr> <tr> <td></td> <td>3</td> <td>4 730</td> <td>+160</td> <td>+380</td> <td>+240</td> <td>+700</td> <td>+210</td> <td>+15</td> <td>0</td> <td>+800</td> </tr> </tbody> </table>						Category	LDG CONF	REF DIST (ft) for 63T	Per 1T above 63T	Per 5kt	Per 1000ft above SL	Per 5kt TW	Per 10°C above ISA	Per 1% Down Slope	Per Thrust Reverser Operative	if QVV PROC applied	Maximum MANUAL	FULL	4 240	+140	+350	+200	+630	+180	+15	0	+800		3	4 730	+160	+380	+240	+700	+210	+15	0	+800																																												
Category	LDG CONF	REF DIST (ft) for 63T	Per 1T above 63T	Per 5kt	Per 1000ft above SL	Per 5kt TW	Per 10°C above ISA	Per 1% Down Slope	Per Thrust Reverser Operative	if QVV PROC applied																																																																									
Maximum MANUAL	FULL	4 240	+140	+350	+200	+630	+180	+15	0	+800																																																																									
	3	4 730	+160	+380	+240	+700	+210	+15	0	+800																																																																									
1	<p>2 - MEDIUM TO POOR</p> <table border="1"> <thead> <tr> <th>Category</th> <th>LDG CONF</th> <th>REF DIST (ft) for 63T</th> <th>Per 1T above 63T</th> <th>Per 5kt</th> <th>Per 1000ft above SL</th> <th>Per 5kt TW</th> <th>Per 10°C above ISA</th> <th>Per 1% Down Slope</th> <th>Per Thrust Reverser Operative</th> <th>if QVV PROC applied</th> </tr> </thead> <tbody> <tr> <td>Maximum MANUAL</td> <td>FULL</td> <td>5 540</td> <td>+130</td> <td>+330</td> <td>+210</td> <td>+630</td> <td>+190</td> <td>+20</td> <td>0</td> <td>+800</td> </tr> <tr> <td></td> <td>3</td> <td>5 690</td> <td>+110</td> <td>+320</td> <td>+190</td> <td>+600</td> <td>+170</td> <td>+20</td> <td>0</td> <td>+800</td> </tr> <tr> <td>AUTOBRAKE MED</td> <td>FULL</td> <td>5 630</td> <td>+120</td> <td>+340</td> <td>+210</td> <td>+630</td> <td>+190</td> <td>+20</td> <td>0</td> <td>+800</td> </tr> <tr> <td></td> <td>3</td> <td>5 830</td> <td>+140</td> <td>+440</td> <td>+210</td> <td>+660</td> <td>+190</td> <td>+170</td> <td>0</td> <td>+800</td> </tr> <tr> <td>AUTOBRAKE LOW</td> <td>FULL</td> <td>6 490</td> <td>+150</td> <td>+480</td> <td>+230</td> <td>+680</td> <td>+220</td> <td>+190</td> <td>0</td> <td>+800</td> </tr> <tr> <td></td> <td>3</td> <td>6 490</td> <td>+150</td> <td>+480</td> <td>+230</td> <td>+680</td> <td>+220</td> <td>+190</td> <td>0</td> <td>+800</td> </tr> </tbody> </table> <p>(1) Automatic Landing correction: if CONF FULL, add 60ft; if CONF 3, add 75ft. (2) Weight correction: if CONF FULL, subtract 50ft per 1T below 63T; if CONF 3, subtract 60ft per 1T below 63T.</p>						Category	LDG CONF	REF DIST (ft) for 63T	Per 1T above 63T	Per 5kt	Per 1000ft above SL	Per 5kt TW	Per 10°C above ISA	Per 1% Down Slope	Per Thrust Reverser Operative	if QVV PROC applied	Maximum MANUAL	FULL	5 540	+130	+330	+210	+630	+190	+20	0	+800		3	5 690	+110	+320	+190	+600	+170	+20	0	+800	AUTOBRAKE MED	FULL	5 630	+120	+340	+210	+630	+190	+20	0	+800		3	5 830	+140	+440	+210	+660	+190	+170	0	+800	AUTOBRAKE LOW	FULL	6 490	+150	+480	+230	+680	+220	+190	0	+800		3	6 490	+150	+480	+230	+680	+220	+190	0	+800
Category	LDG CONF	REF DIST (ft) for 63T	Per 1T above 63T	Per 5kt	Per 1000ft above SL	Per 5kt TW	Per 10°C above ISA	Per 1% Down Slope	Per Thrust Reverser Operative	if QVV PROC applied																																																																									
Maximum MANUAL	FULL	5 540	+130	+330	+210	+630	+190	+20	0	+800																																																																									
	3	5 690	+110	+320	+190	+600	+170	+20	0	+800																																																																									
AUTOBRAKE MED	FULL	5 630	+120	+340	+210	+630	+190	+20	0	+800																																																																									
	3	5 830	+140	+440	+210	+660	+190	+170	0	+800																																																																									
AUTOBRAKE LOW	FULL	6 490	+150	+480	+230	+680	+220	+190	0	+800																																																																									
	3	6 490	+150	+480	+230	+680	+220	+190	0	+800																																																																									

RWY COND Cancel

Select runway condition from list

- 6-Dry
- 5-Good
- 4-Good to medium
- 3-Medium
- 2-Medium to poor
- 1-Poor



Chapter on the Situation for Takeoff

- RWYCC provides information on friction only
- At takeoff fluid contaminants generate drag
 - Displacement
 - Compression
 - Impingement
- Takeoff can be limited by
 - Distance needed to accelerate to lift-off speed
 - Distance needed to accelerate to decision speed V_1 and come to full stop on available runway
- Contaminant drag must be accounted for in takeoff computations

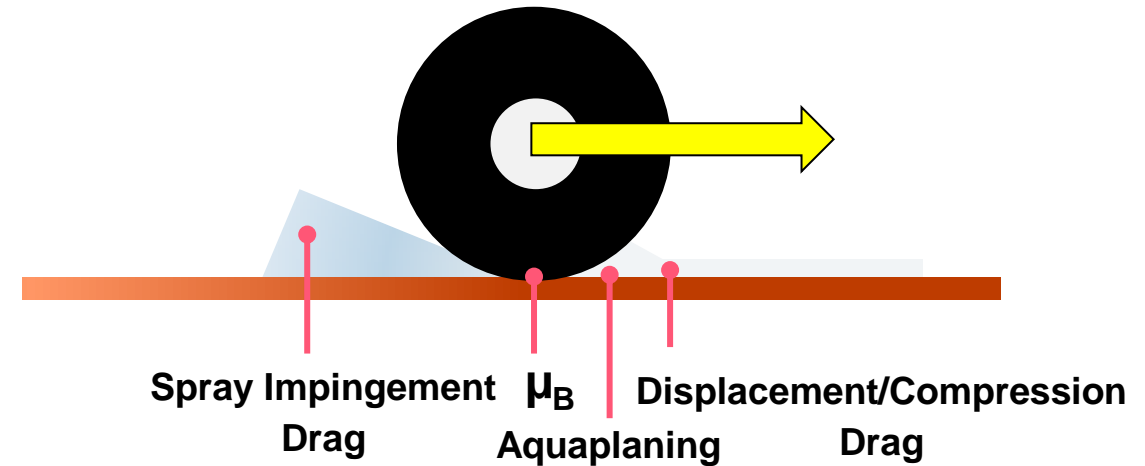

Takeoff computation must be done for prevailing contaminant!

Takeoff

Computation with Contaminant Type and Depth

- Takeoff performance presented for contaminant type and depth

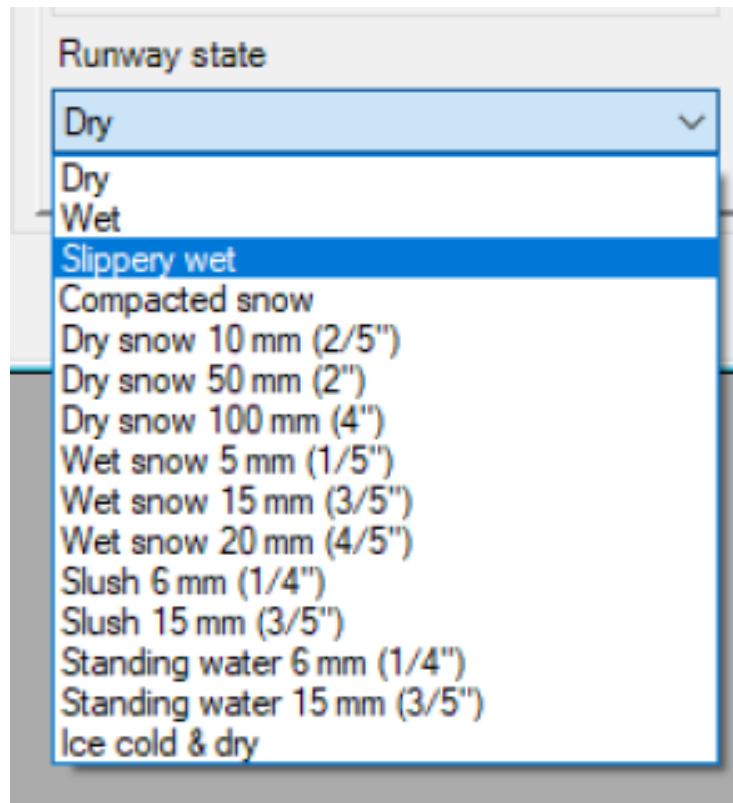

Takeoff

Computation with Contaminant Type and Depth

- Typical manufacturer data certified to CS25 pre-Amdt 2 does not cover many contaminants in the RCAM
- Missing:
 - Frost
 - Dry Snow
 - Wet Snow
 - Compacted Snow at OAT above -15°C
 - Slippery When Wet
 - Ice Cold & Dry
- **APM offers advice on how to compute for missing contaminants conservatively**

Runway condition assessment matrix (RCAM)			
Assessment criteria		Downgrade assessment criteria	
Runway condition code	Runway surface description	Aeroplane deceleration or directional control observation	Pilot report of runway braking action
6	• DRY	---	---
5	<ul style="list-style-type: none"> • FROST • WET (The runway surface is covered by any visible dampness or water less than 3 mm deep) Less than 3 mm depth: <ul style="list-style-type: none"> • SLUSH • DRY SNOW • WET SNOW 	Braking deceleration is normal for the wheel braking effort applied AND directional control is normal.	GOOD
4	-15°C and Lower outside air temperature: <ul style="list-style-type: none"> • COMPACTED SNOW 	Braking deceleration OR directional control is between Good and Medium.	GOOD TO MEDIUM
3	<ul style="list-style-type: none"> • WET ("Slippery wet" runway) • DRY SNOW or WET SNOW (Any depth) ON TOP OF COMPACTED SNOW 3 mm and more depth: <ul style="list-style-type: none"> • DRY SNOW • WET SNOW Higher than -15°C outside air temperature ¹ : <ul style="list-style-type: none"> • COMPACTED SNOW 	Braking deceleration is noticeably reduced for the wheel braking effort applied OR directional control is noticeably reduced.	MEDIUM
2	3 mm and more depth of water or slush: <ul style="list-style-type: none"> • STANDING WATER • SLUSH 	Braking deceleration OR directional control is between Medium and Poor.	MEDIUM TO POOR
1	• ICE ²	Braking deceleration is significantly reduced for the wheel braking effort applied OR directional control is significantly reduced.	POOR
0	<ul style="list-style-type: none"> • WET ICE ² • WATER ON TOP OF COMPACTED SNOW ² • DRY SNOW or WET SNOW ON TOP OF ICE ² 	Braking deceleration is minimal to non-existent for the wheel braking effort applied OR directional control is uncertain.	LESS THAN POOR

Takeoff

Computation with Downgraded RWYCC

METAR

PAMC 13^{09:53} Z AUTO 000°00^{KT} 10SM CLR M09/M12
A2972 RMK AO2 SLP073 T10891117 TSNO=

FICON

!MCG 03/104 MCG RWY 05 FICON 2/2/2 100 PCT
COMPACTED SN OBS AT 1803121907. 1803121907-
1803131907

APM recommends “to delay take-off. However, [...], it may be sufficient to determine performance in nominal conditions and to adopt appropriate operational procedures such as considering reduced crosswind limits, using the full length of available runway and avoiding rolling take-off.”

Runway condition assessment matrix (RCAM)			
Assessment criteria		Downgrade assessment criteria	
Runway condition code	Runway surface description	Aeroplane deceleration or directional control observation	Pilot report of runway braking action
6	<ul style="list-style-type: none"> • DRY 	---	---
5	<ul style="list-style-type: none"> • FROST • WET (The runway surface is covered by any visible dampness or water less than 3 mm deep) <p>Less than 3 mm depth:</p> <ul style="list-style-type: none"> • SLUSH • DRY SNOW • WET SNOW 	Braking deceleration is normal for the wheel braking effort applied AND directional control is normal.	GOOD
4	<p>-15°C and Lower outside air temperature:</p> <ul style="list-style-type: none"> • COMPACTED SNOW 	Braking deceleration OR directional control is between Good and Medium.	GOOD TO MEDIUM
3	<ul style="list-style-type: none"> • WET (“Slippery wet” runway) • DRY SNOW or WET SNOW (Any depth) ON TOP OF COMPACTED SNOW <p>3 mm and more depth:</p> <ul style="list-style-type: none"> • DRY SNOW • WET SNOW <p>Higher than -15°C outside air temperature:</p> <ul style="list-style-type: none"> • COMPACTED SNOW 	Braking deceleration is noticeably reduced for the wheel braking effort applied OR directional control is noticeably reduced.	MEDIUM
2	<p>3 mm and more depth of water or slush:</p> <ul style="list-style-type: none"> • STANDING WATER • SLUSH 	Braking deceleration OR directional control is between Medium and Poor.	MEDIUM TO POOR
1	<ul style="list-style-type: none"> • ICE ² 	Braking deceleration is significantly reduced for the wheel braking effort applied OR directional control is significantly reduced.	POOR
0	<ul style="list-style-type: none"> • WET ICE ² • WATER ON TOP OF COMPACTED SNOW ² • DRY SNOW or WET SNOW ON TOP OF ICE ² 	Braking deceleration is minimal to non-existent for the wheel braking effort applied OR directional control is uncertain.	LESS THAN POOR

Thank you

