



INTERNATIONAL CIVIL AVIATION ORGANIZATION
EASTERN AND SOUTHERN OFFICE

First Meeting of the AFI VSAT Networks Managers(AFI VSAT/1)
(Kwa-Zulu Natal, South Africa, 13 to 15 June 2011)

Agenda Item 6: Need for a regional project

DRAFT OF ATN ROUTING ARCHITECTURE PLAN

(Presented by the Secretariat)

SUMMARY

This working paper presents a draft of the ATN Regional Plan.

Action by the meeting is contained in paragraph 3.

REFERENCES

- ICAO Global Air Navigation Plan (Doc 9750)
- ICAO Doc 9880 - Manual on detailed technical specifications for the Aeronautical Telecommunication Network (ATN) using ISO/OSI Standards and Protocols
- ICAO Doc 9896 – Manual on the Aeronautical Telecommunication Network (ATN) using Internet Protocol Suite (IPS) Standards and Protocols

1. INTRODUCTION

1.1 This document provides technical guidance on the Planning and Implementing the transition to the Aeronautical Telecommunication Network (ATN) for ground communication within the ICAO AFI Region.

2. DISCUSSION

2.1 The routing architecture is based upon the need for a ground-ground infrastructure to eventually replace the existing AFTN infrastructure. For this reason, the routing architecture uses the existing AFTN infrastructure as a guideline for the positioning of ATN equipment.

2.2 The routing architecture is designed primarily for the ground-ground environment. It is intended that this architecture will be suitable as the routing architecture for the introduction of the air-ground communication requirements.

3. CONCLUSION

3.1 The meeting is invited to review the routing architecture presented in this paper and to suggest, as required, further modifications/additions to the presented architecture.

-END-

EXECUTIVE SUMMARY

This document provides technical guidance on the Planning and Implementing the transition to the Aeronautical Telecommunication Network (ATN) for ground communication within the ICAO AFI Region.

The routing architecture is based upon the need for a ground-ground infrastructure to eventually replace the existing AFTN infrastructure. For this reason, the routing architecture uses the existing AFTN infrastructure as a guideline for the positioning of ATN equipment.

The routing architecture is designed primarily for the ground-ground environment. It is intended that this architecture will be suitable as the routing architecture for the introduction of the air-ground communication requirements.

Guidance Material for ATN Router Implementation (Draft 1.0)

1 INTRODUCTION

This document presents an initial plan for the routing architecture within the AFI Region.

1.1 Terms used

Aeronautical Fixed Telecommunication Network (AFTN): a low-speed network providing the majority of ground-ground data communication services within the ICAO realm. This term is defined in ICAO Annex 10.

Boundary Intermediate Systems (BIS): a router that supports IDRP and routes PDUs to more than one routing domain. This term is defined in ICAO Doc. 9705.

Backbone Boundary Intermediate Systems (BBIS): a router that primarily routes PDUs between routing domains and does not support End Systems.

Note: This definition is similar to that found in ICAO Doc. 9705 and is meant to be consistent with that definition. This definition is made on the assumption that this version of the routing architecture is limited to the ground-ground infrastructure.

End Boundary Intermediate Systems (EBIS): a router that primarily routes PDUs between routing domains and connected End Systems.

End Systems (ES): an ATN system that supports one or more applications and that is a source and/or destination for PDUs.

Inter-Regional Boundary Intermediate Systems (IRBIS): a router that routes PDUs between systems (both End Systems and Boundary Intermediate Systems) within the Region with routers outside of the Region. These routers are the entry points into the Region and exit points from the Region for PDUs.

Network Service Access Point (NSAP) (address): a 20-octet value that uniquely identifies an interface between the Transport Layer and the Network Layer. In the ATN it provides the address of transport entity providing ATN Internet services.

1.2 Acronyms used

AFTN	-	Aeronautical Fixed Telecommunication Network
BIS	-	Boundary Intermediate Systems
BBIS	-	Backbone Boundary Intermediate Systems
CLNP	-	Connectionless Network Protocol
EBIS	-	End Boundary Intermediate Systems
ES	-	End System
IDRP	-	Inter-Domain Routing Protocol
IS	-	Intermediate System
PDU	-	Protocol Data Unit

2 ROUTING DOMAIN FUNDAMENTALS

The ATN consists of a set of End-Systems (ESs) and a set of Intermediate Systems (ISs). ESs are the source and destination of all data and are where the applications reside. ISs are better known as routers and relay PDUs from one system to another.

The ISs and ESs are organized into *Routing Domains*. Routing Domains are used to define sets of systems (that typically operate together) into clusters. These clusters have two major properties:

- they are controlled by a single administration/organization, and

 GUIDANCE MATERIAL FOR ATN ROUTER IMPLEMENTATION (DRAFT 1.0)

- a significant amount of the traffic is internal to the cluster.

The single most important characteristic is that they are controlled by a single administration or organization. This characteristic is manifested in technical terms by mutual trust between all routers in a routing domain. Routing protocols are based on the fact that the information exchanged between *intra*-domain routers can be trusted. No special reliability or trust is required to accept information about advertised routes.

The second characteristic, most traffic is internal to a routing domain, is more an artifact of proper network engineering.

Routing domains are established through the NSAP addressing conventions established for the ATN in Doc. 9705, Sub-Volume 5. All systems with NSAP addresses defined with the same address prefix are by definition in the same routing domain.

2.1 Intra-Domain Routing

Intra-domain routing is the routing of PDUs from the source to destination where both are in the same domain. Intra-domain routing implies one or more ISs capable of routing PDUs across the domain. Examples of intra-domain routing would be CLNP-capable routers exchanging PDUs between two Local Area Networks.

Since the ATN is specified across State boundaries, there are no SARPs requirements for intra-domain routing. The choice and configuration of internal routers is a local matter.

2.2 Inter-Domain Routing

The central definition of routing in the ATN is concerned with inter-domain routing. This is a particularly difficult problem since by the very nature of inter-domain routing, the information received cannot be fully trusted.

Inter-domain routing is based upon the mutual distrust of the received routing information. First, reliability mechanisms must be built-in to ensure the reliable transfer of the information. Second, the received information must be filtered to ensure that it meets the suitability constraints of the received system (in other words, can it be believed.)

After receiving the routing information, the inter-domain router must build routing tables based upon its internal policy about routing its data.

2.3 Types of Routing Domains

There are two basic types of routing domains: end routing domains, and transit routing domains.

An end routing domain routes PDUs to and from end-systems within its routing domain. Figure 1 shows an end routing domain.

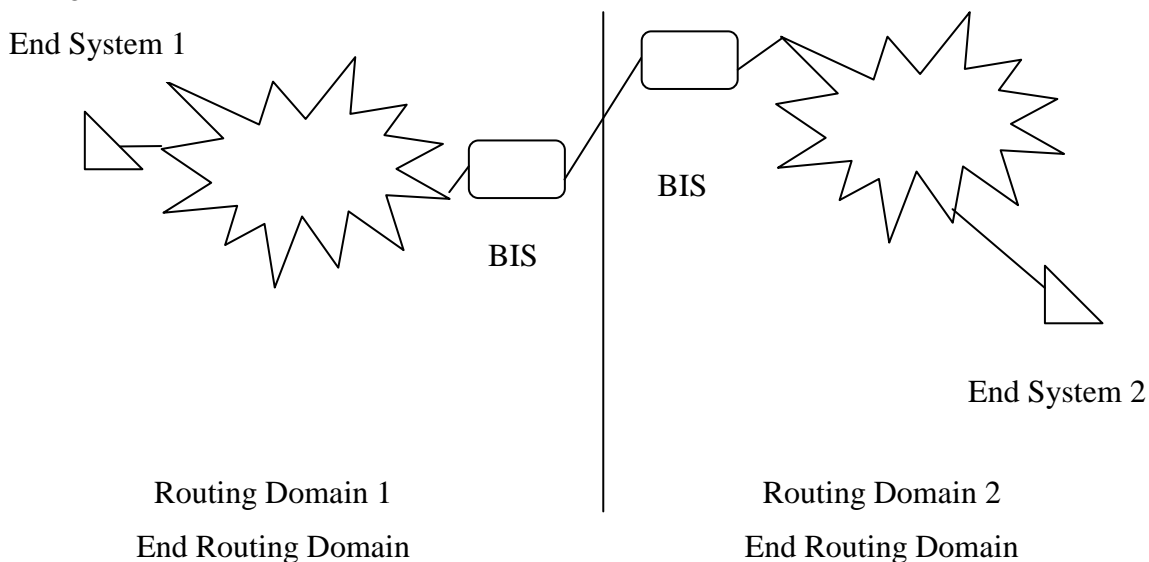

Guidance Material for ATN Router Implementation (Draft 1.0)

Figure 1 – End Routing Domains

A transit routing domain routes PDUs between two or more routing domains, and may as an option also act as an end routing domain. An example of a transit domain is where a set of backbone routers is configured in their own routing domain with all of the end systems in end routing domains attached to the backbone.

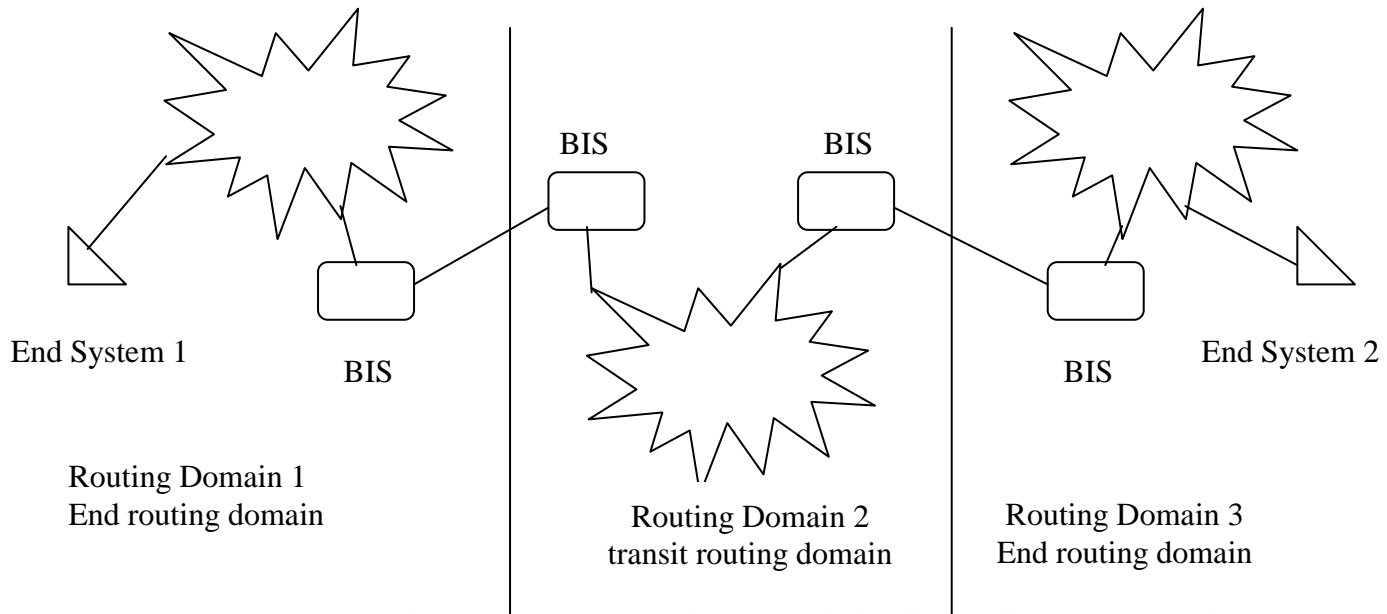

Note: A transit routing domain may or may not be part of the backbone. That is, a routing domain may consist of BISs none of which are backbone routers.

Figure 2 – Transit Routing Domains

2.4 Routing Domain Construction

Based on the above, a routing domain consists of at least one inter-domain router.

Note: There must be at least one BIS. There is no requirement for any other equipment.

Routing domains are elements of the physical structure of the ATN.

3 ROUTER FUNDAMENTALS

All routers discussed within this document are ICAO Doc. 9705 compliant Boundary Intermediate Systems (BISs).

Note: Individual States may elect to use other routers that do not comply with the ATN IDRP requirements as found in ICAO Doc. 9705 within the limits of their own States. These router are internal State issues and outside the scope of this document.

3.1 Boundary Intermediate System Overview

Boundary Intermediate Systems comprise the interfaces between networks, and in particular, between different routing domains. The term “Boundary Intermediate System” can often be replaced with the more common term “router”.

An important consideration in developing the routing architecture is the different roles that routers take within the ATN environment.

3.2 Router Types

There will be two primary types of BISs employed within the Region:

- Backbone BISs (BBISs), and

 GUIDANCE MATERIAL FOR ATN ROUTER IMPLEMENTATION (DRAFT 1.0)

- End BISs (EBISs).

3.2.1 Backbone BISs

A BBIS is a router that primarily routes PDUs between routing domains. These routers are typically higher performance routers that aid in the efficient flow of data between domains. BBISs may have End-Systems connected to them, but often are limited to only router-to-router connections.

BBISs can be further subdivided into Inter-regional BBISs and Regional BBISs. Inter-regional Backbone BBISs are those backbone routers that connect to BBISs in other regions.

Regional BBISs are backbone routers that only connect to routers within the Region.

Note 1: A single high performance router may act as both a Regional BBIS and an Inter-regional BBIS based upon meeting the requirements for performance and reliability.

Note 2: For completeness of the routing architecture, it must be mentioned that the routers out-side of the Region to which Inter-regional Backbone BISs attach are, in fact, Inter-regional Backbone BISs in the other Region.

Note 3: The interconnection of backbone BISs typically require higher capacity communication lines based on the consolidation of traffic through those backbone routers. Even though the architecture takes into account existing AFTN infrastructure facilities, the need to upgrade the communication facilities as traffic through the backbone increases may be necessary.

Note 4: It is possible for some States to provide transit routing from their routing domains to the routing domains of other States using BISs that are not backbone routers.

3.2.2 End BISs

End BISs are connected to one or more BBISs and provide routing services to a single routing domain. Further, End BISs do not act as a transit router for passing PDUs between other routing domains.

4 AFI REGIONAL ROUTING ARCHITECTURE

The AFI Regional routing architecture is based upon several concepts:

1. from a routing domain point of view, the Region can be considered an “autonomous” area, that is, there is a difference between routers located within the Region and outside the Region.
2. routing domains and confederations of routing domains may be applied to areas within the Region.
3. States will make their own implementation and transition decisions.

The routing architecture can be divided into several distinct parts:

- the definition of the backbone routing structure for passing information between routing domains within the Region;
- the definition of the routing structure for passing information from this Region to other Regions;
- the definition of the routing structure between routing domains not on the backbone; and
- the definition of the routing structure for use in end-routing domains.

The first component is the definition of the backbone routing structure that supports the exchange of data within the Region. This part defines the interconnection of the major communication facilities in the Region and how they cooperate to link all of the systems in the Region.

The second part is needed to define how data will be routed between the systems within the Region with those systems outside the Region. More importantly, the structure describes how all global ATN systems are accessible from systems in the Region.

Guidance Material for ATN Router Implementation (Draft 1.0)

The third component is the definition of the structure that allows end routing domains to exchange data across the backbone to another end routing domain. This part defines how the end routing domains connect through the backbone.

The fourth component defines the routing structure that is used within an end routing domain. This part defines how the individual routing domains may be used to pass data.

4.1 Regional Backbone

The definition of a Regional Backbone is based upon the efficiencies that may be realized by concentrating the ATN traffic at major communication centres and using the economy of scale in passing this information between major communication centres.

The rationale for defining Regional backbone sites is based upon existing and planned VSAT networks in the AFI Region and the flow of both AFTN traffic and possible future air-ground ATN traffic.

Within the Region there exist three VSAT networks (AFISNET, CAFSAT, SADC) and a planned one (NAFISAT) that can be used to simplify the definition of the backbone architecture.

However, it must be understood that the expected growth in communication traffic over the ATN could quickly exceed the capabilities of the existing communication infrastructure. Planning for the increased traffic loads will be needed as soon as ATN traffic begins to flow.

The architecture and communication requirements define a routing plan that incorporates alternate routing and communication paths so that no single router or communication failure can isolate major parts of the Region.

The initial AFI BBISs sites are defined in the following table by identifying those communication centres that are participating in more than one VSAT network as shown in **Appendix A**. Additional backbone sites will need to be identified in the future for increased reliability of the interconnections between the networks. This is done in subsequent paragraphs.

Item	ATN backbone router site	State
1	Antananarivo	Madagascar
2	Dakar	Senegal
3	Dar es Salaam	Tanzania
4	Johannesburg	South Africa
5	Kinshasa	Dem. Rep. of Congo
6	Luanda	Angola
7	Mauritius	Mauritius
8	N'djamena	Chad

Table 4.1 - Definition of initial AFI ATN Backbone router sites

At each ATN Backbone site, there should be at least one BBIS. States that are to be invited to committing to operate backbone routers are identified in the table above.

4.1.1 AFI Backbone router requirements

The definition of BBIS and the location of these routers may be affected by the requirements for backbone routers. A backbone router must meet several performance and reliability requirements:

- Availability
- Reliability
- Capacity; and

 GUIDANCE MATERIAL FOR ATN ROUTER IMPLEMENTATION (DRAFT 1.0)

- Alternate routing.

4.1.1.1 Availability

A backbone router must provide a high-level of availability (24 hours a day, 7 days a week).

4.1.1.2 Reliability

A backbone router must be very reliable system that may require redundant hardware or more than one router per site.

4.1.1.3 Capacity

As a communication concentrator site, a backbone router must be capable of supporting significantly more traffic than other ATN routers.

4.1.1.4 Alternate routing

Based upon the need for continuity of service, backbone routers will require multiple communication links with a minimum of two and preferably three or more backbone routers to guarantee alternate routing paths in case of link or router failure.

4.1.1.5 Routing policies

States providing Regional BBISs must be capable of supporting routing policies that allow for Regional transit traffic and for dynamic re-routing of traffic based upon loading or link/router failures.

4.2 Inter-Regional Backbone

The second component of the AFI Regional Routing Architecture is the definition and potential location of Inter-Regional Backbone Routers. The manner in which this architecture was developed was to ensure that the use of the existing communication infrastructure is possible to the greatest degree. The use of the existing communication infrastructure should reduce the overall cost of transitioning to the ATN.

To re-state from the previous section, the Inter-Regional BBISs provide communication from routers within the AFI Region to routers in other regions. These Inter-Regional BBISs provide vital communications across regions and therefore need to have redundant communication paths and high availability. (Note: This can be accomplished through multiple routers at different locations.)

Within the current AFTN network environment, the following locations have been identified to initially serve centres outside the AFI Region:

Entry/Exit Centre	Region served
Addis Ababa	Middle East
Algiers	Europe
Casablanca	Europe
Cairo	Europe, Middle East
Dakar	South America
Johannesburg	Asia/Pacific, South America
Nairobi	Asia
Tunis	Europe

Guidance Material for ATN Router Implementation (Draft 1.0)

Table 4.2 - Centres with circuits to other Inter- Regional Backbones

For the transition to the ATN, connectivity to the other Regions should be a priority. This is especially important as other Regions begin the transition to the ATN and begin deploying ATN BISs.

4.2.1 Long Term Implementation

The transition to a fully implemented ATN requires that connectivity amongst the ICAO regions be robust. That is, there is the need to ensure alternate paths and reliable communication. Table 4.2 presents a minimal Inter-Regional Backbone that provides a minimum of 2 circuits to other ICAO regions that communicate directly with the AFI Region. For longer term implementation of the ATN, it would be advisable to have 3 circuits to each Region.

4.2.2 Initial Implementation

Note: Information is needed on the plans of States in implementing ATN.

The initial implementation of the ATN, outside of the AFI Region, will most likely be in North America, Europe and Asia/Pacific. Therefore, initial transition planning in AFI may focus on Europe and Asia/Pacific.

For connecting to Europe, there should be four (4) Inter-Regional BBISs. For example, the following locations would be candidates for such routers:

Algiers, Cairo, Casablanca and, Tunis.

Note: The locations presented above are examples of possible router sites. The selection of actual locations will be based on implementation schedules and circuit availabilities.

For connecting to the Middle East, Inter-Regional BBISs may be located at the locations of the existing AFTN centres, Cairo and Addis Ababa. However, these routers would not be needed until such time as ATN traffic is destined for that Region and the location of the routers would be determined at that time.

For connecting to the ASIA/PAC, Inter-Regional BBISs may be located at the locations of the existing AFTN centres, Johannesburg and Nairobi. However, these routers would not be needed until such time as ATN traffic is destined for that Region and the location of the routers would be determined at that time.

For connecting to the SAM Region, Inter-Regional BBISs may be located at the locations of the existing AFTN centres, Dakar and Johannesburg. However, these routers would not be needed until such time as ATN traffic is destined for that Region and the location of the routers would be determined at that time. In the future, Luanda could be added for interface with the SAM Region.

4.3 Routing between Backbone Routers and Routing Domains

The third component of the AFI ATN routing architecture is the definition of the routing structure between end routing domains within the AFI Region through the regional ATN backbone. This is done by linking routing domains within the coverage area of each VSAT network to the ATN backbone sites on the same network. In this process additional backbones are identified.

Based upon the exiting VSAT network coverage areas, sub-regions are defined for routing efficiencies. These sub-regions are used to concentrate traffic. The goal of this architecture is to use the existing communication infrastructure and the facilities available at existing AFTN centres to the maximum degree possible.

Within the AFISNET area, six major routing domains can be identified:

- ASECNA member States, which could form a routing confederation
- Ghana
- Nigeria
- Roberts FIR
- Sal FIR; and

 GUIDANCE MATERIAL FOR ATN ROUTER IMPLEMENTATION (DRAFT 1.0)

- Sao Tome and Principe.

Within the ASECNA ensemble, two additional backbones could be located at Brazzaville and Niamey to concentrate traffic as in the current AFTN.

In the Ghana domain, Accra is being linked to Sao Tome by VSAT for VHF extension. This facility could be used in the future to link the Sao Tome domain to the ATN. Thus Accra BIS will be a transit router for Sao Tome. For added reliability, Lagos BIS should transit through Accra, while Kano BIS is linked to N'djamena and Niamey.

In the SADC VSAT coverage area, each State constitutes a routing domain that will be linked to the Johannesburg BBIS.

Concerning the area **which will** be covered by the NAFISAT, each State is also assumed to have one routing domain. The additional BBIS identified is at Khartoum. Each routing domain has at least two links to the ATN. The sub-regions are defined in Table 4.3. The table is organized with one site identified as a potential backbone router site identified above. This site is listed first and in bold text. The remainder of the sites in each sub-region follows.

Note: The identified backbone router sites are only examples. Actual backbone router sites will be determined by implementation schedules and States' willingness to implement backbone routers.

1. Location (State) of BBISs
<p>Addis Ababa (Ethiopia) Sub-Regional Sites: Asmara, Djibouti, Mogadishu Other BBIS sites: Khartoum, Nairobi Other Regions: MID</p>
<p>Algiers (Algeria) Sub-Regional Sites: None Other BBIS sites: Casablanca, Dakar, Niamey, Tunis Other Regions: EUR</p>
<p>Antananarivo (Madagascar) Sub-Regional sites: Comoros, France (Reunion) Other BBIS sites: Johannesburg, Mauritius</p>
<p>Brazzaville (Congo) Sub-Regional Sites: Bangui, Douala, Libreville, Malabo, Other Sub-Region sites: Dakar, N'djamena, Niamey Other Regions: None</p>
<p>Cairo (Egypt) Sub-Regional Sites: Asmara, Tripoli Other BBIS sites: Khartoum, Tunis Other Regions: EUR, MID</p>
<p>Casablanca (Morocco) Sub-Regional Sites: Western Sahara Other BBIS sites: Algiers, Dakar Other Regions: EUR</p>

Guidance Material for ATN Router Implementation (Draft 1.0)

1. Location (State) of BBISs
<p>Dakar (Senegal) Sub-Regional Sites: Abidjan, Bamako, Banjul, Bissau, Conakry, Nouakchott, Sal Other BBIS sites: Algiers, Brazzaville, Casablanca, Johannesburg, Niamey Other Regions: SAM</p>
<p>Dar es Salaam (Tanzania) Sub-Regional Sites: Seychelles Other BBIS sites: Kinshasa, Nairobi</p>
<p>Kinshasa (Democratic Republic of Congo) Sub-Regional sites: Entebbe Other BBIS sites: Dar es Salaam, N'djamena</p>
<p>Johannesburg (South Africa) Sub-Regional Sites: Beira, Bujumbura, Gaborone, Harare, Kigali, Lilongwe, Luanda, Lusaka, Maseru, Manzini, Windhoek Other BBIS sites: Antananarivo, Dar es Salaam, Dakar, Kinshasa, Mauritius Other Regions: ASIA/PAC, SAM</p>
<p>Khartoum (Sudan) Sub-Regional sites: Tripoli Other BBIS sites: Addis Ababa, Cairo, Nairobi, N'djamena</p>
<p>Mauritius (Mauritius) Sub-Regional sites: France (Réunion) Other BBIS sites: Antananarivo, Johannesburg, Nairobi</p>
<p>Niamey (Niger) Sub-Regional Sites: Abidjan, Accra, Kano, Ouagadougou Other BBI sites: Algiers, Brazzaville, Dakar, N'djamena</p>
<p>Nairobi (Kenya) Sub-Regional Sites: Entebbe, Mogadishu, Seychelles Other BBIS sites: Addis Ababa, Dar es Salaam, Khartoum, Mauritius Other Regions: ASIA/PAC</p>
<p>N'djamena (Chad) Sub-regional sites: Kano, Tripoli Other BBIS sites: Brazzaville, Niamey, Kinshasa</p>
<p>Tunis (Tunisia) Sub-regional sites: Tripoli Other BBIS sites: Algiers, Cairo Other Regions: EUR</p>
2. Location (State) Transit BISs

1. Location (State) of BBISs
Abidjan (Côte d’Ivoire) Transit for: Roberstfield
Accra (Ghana) Transit for : Cotonou, , Kano, Lagos, Lome, Sao Tome

Table 4.3 – Definition of AFI Geographic Sub-Regions

4.4 Routing within end domains

The fourth component of the AFI routing architecture is the definition of routing within end domains.

4.4.1 Routing Domains

Each State is expected to have one or more routing domains. Where a State chooses not to implement an ATN BIS, it may choose to incorporate its systems into a routing domain of another State.

The AFI ATN Backbone will consist of routers from the selected States. Each of these routers will be part of its State’s routing domain.

Note: This means that the backbone will not be configured with its own routing domain.

Routing to the backbone and between backbone routers will be controlled through IDRP policies.

Each State will be responsible for the designation of routing policies for its End Systems and End BISs. Individual States will also be responsible for establishing routing policies for routing to its designated BBIS.

The use of routing confederations is for further study. It should be noted that the establishment of routing confederations within the AFI Region could simplify considerably the routing architecture since a routing confederation can be viewed externally as a single routing domain.

4.4.2 End BISs

It is assumed that naming and addressing (and routing domain definition) will be done on a Regional basis. Further, for areas within the Region that may utilize an End BIS serving more than one State, the naming structure will be based on the Regional NSAP format defined in Doc. 9880. Further, States may choose to either implement the Regional (or Sub-Regional) NSAP format or the State NSAP format based on whether it installs a BIS.

4.5 AFI Regional Routing Architecture

Summarizing the information presented above, the AFI Regional Backbone network will consist of at least one BBIS router in each of the sub-regions identified above. The actual location of the routers will be based upon implementation schedules and the choices of States.

The Inter-Regional BBISs may be configured to provide both Regional routing services and Extra-Regional routing services. However, these routers must be engineered with sufficient performance capabilities to provide such services.

The chart at **Appendix B** shows the configuration of the AFI routing architecture.

4.5.1 Transition Issues

This area needs further work. Information about plans of the States is required.

5 ATN Transition

Based upon the previous sections, the implementation of the ATN within the AFI Region may require considerable planning for the transition of the AFTN.

Guidance Material for ATN Router Implementation (Draft 1.0)

5.1 Initial Regional Implementation

The very beginning of ATN implementation will be bilateral testing between States. For this scenario, each State will need at a minimum:

- an ATN-compliant router,
- a means for managing the router,
- an ATN application, and
- a circuit connecting the States.

States involved in bilateral ATN trials should consider the use of the trial infrastructure in expanding the ATN throughout the Region.

Regional ATN Implementation

At a certain time, sufficient bilateral trials will be underway to permit a region-wide ATN network based upon the plan presented above. As each State implements the ATN applications and network infrastructure, it will be added to the Regional infrastructure according to this plan.

-END-

APPENDIX A

IDENTIFICATION OF BACKBONE ROUTER SITES

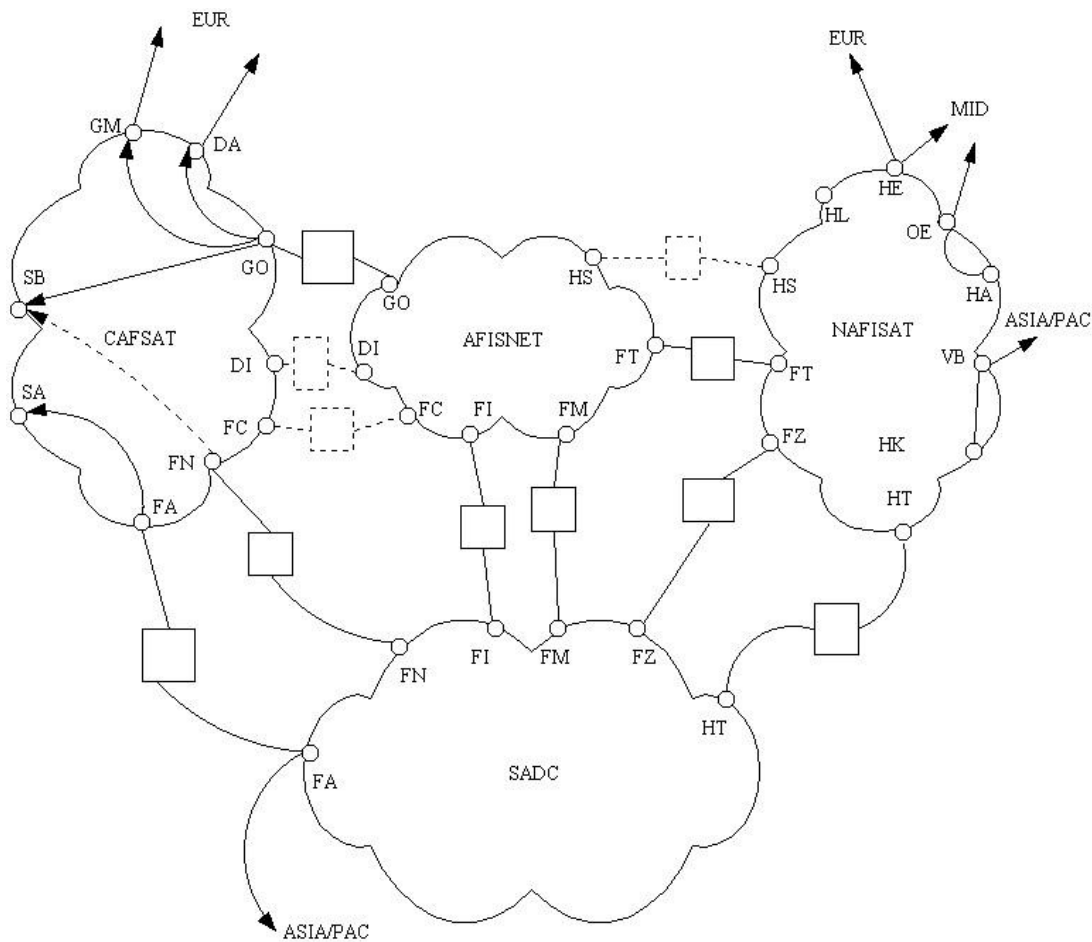

APPENDIX B

ATN BACKBONE

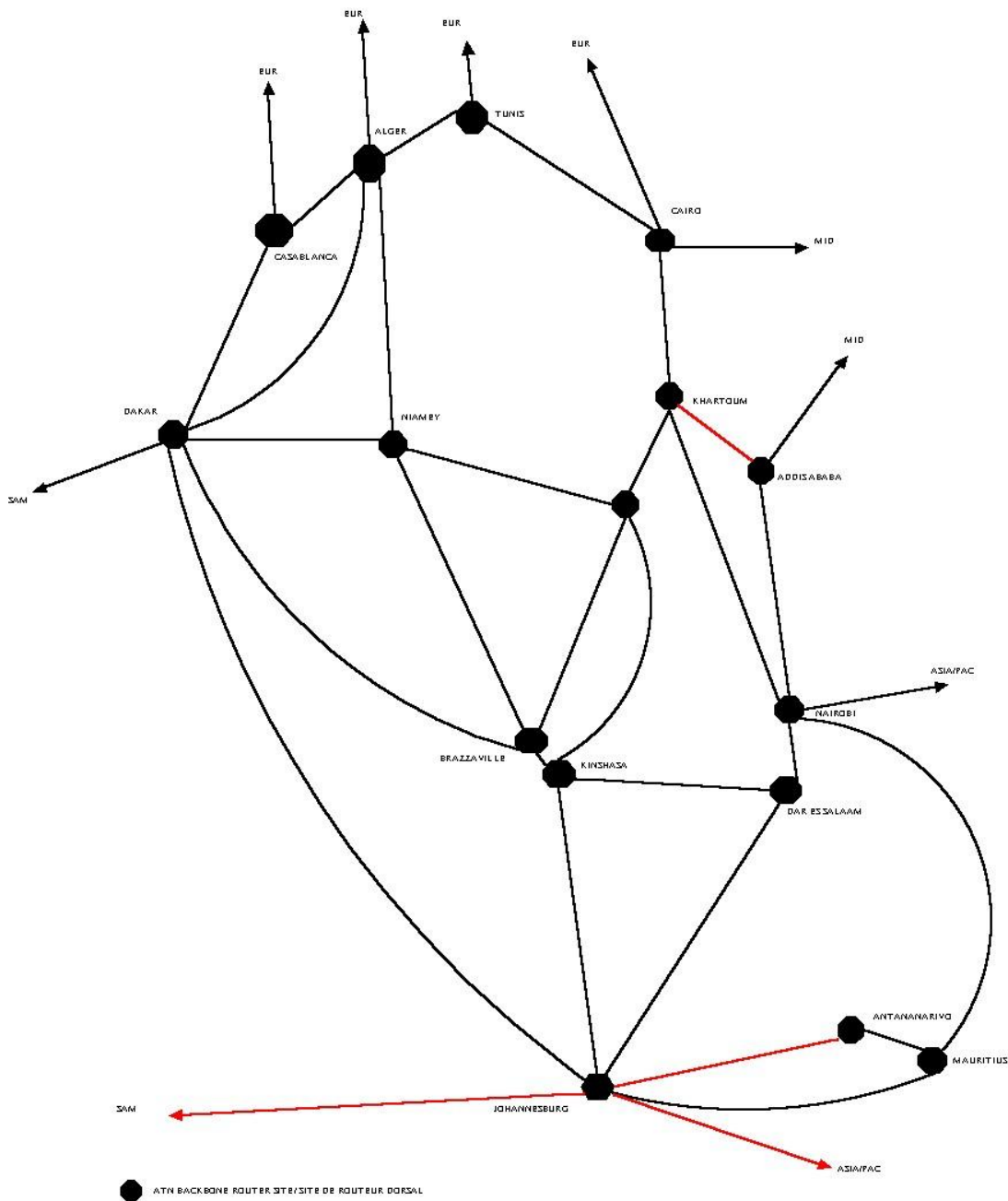

DRAFT AFI BACKBONE ROUTER INTERCONNECTION
PROJET D'INTERCONNEXION DE ROUTEURS DORSAUX DE LA REGION AFI
