



## INTERNATIONAL CIVIL AVIATION ORGANIZATION

**TWENTY-SECOND MEETING OF THE  
ASIA/PACIFIC AIR NAVIGATION PLANNING AND  
IMPLEMENTATION REGIONAL GROUP (APANPIRG/22)**

Bangkok, Thailand, 5-9 September 2011

**Agenda Item 3:  
3.1**
**Performance Framework for Regional Air Navigation Planning  
and Implementation- AOP**
**AMENDMENT PROPOSALS TO ANNEX 14, VOLUME II**

(Presented by Secretariat)

**SUMMARY**

The Air Navigation Commission at the eight meeting of its 186<sup>th</sup> Session (15 April 2011) considered the proposals developed by the second meeting of the Aerodromes Panel (AP) to amend the SARPs in Annex 14, Volume II- *Heliports*. The proposed amendment to Annex 14, Volume II is envisaged for applicability on 15 November 2012.

*Strategic Objectives:*

A: **Safety** – Enhance global civil aviation safety

C: **Environmental Protection and Sustainable Development of Air Transport** – Foster harmonized and economically viable development of international civil aviation that does not unduly harm the environment

GPI-13 Aerodrome design and management

GPI-14 Runway operations

Action by APANPIRG is at Para 3 to this paper.

**1. INTRODUCTION**

1.1 The Air Navigation Commission at the eight meeting of its 186<sup>th</sup> Session (15 April 2011) considered the proposals developed by the second meeting of the Aerodromes Panel (AP) to amend the SARPs in Annex 14, Volume II - Heliports relating to heliports. In State Letter AN 4/1.1.51-11/31 dated 20 April 2011 ICAO requested Contracting States and appropriate international organizations for comments to reach by 31 July 2011.

**2. DISCUSSION**

2.1 The amendment proposals to Annex 14, Volume II addresses the second part of a two part comprehensive review and updating of the document. As such there are multiple proposals covering various subjects, including definitions, heliport data, physical characteristics, obstacle restriction and removal and visual aids.

2.2 The proposed amendment to Annex 14, Volume II is envisaged for applicability on 15 November 2012.

**3. ACTION BY THE MEETING**

3.1 The meeting is invited to note the information provided in this paper.

-----



International  
Civil Aviation  
Organization

Organisation  
de l'aviation civile  
internationale

Organización  
de Aviación Civil  
Internacional

Международная  
организация  
гражданской  
авиации

منظمة الطيران  
المدني الدولي

国际民用  
航空组织

Tel.: +1 (514) 954-6717

Ref.: AN 4/1.1.51-11/31

20 April 2011

**Subject:** Proposal for the amendment of Annex 14,  
Volume II concerning heliports

**Action required:** Comments to reach Montréal by  
31 July 2011

Sir/Madam,

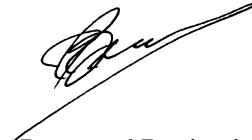
1. I have the honour to inform you that the Air Navigation Commission, at the eighth meeting of its 186th Session on 15 March 2011, considered the proposals developed by the second meeting of the Aerodromes Panel (AP) to amend the SARPs in Annex 14, Volume II – *Heliports* relating to the design of heliports and authorized their transmission to Contracting States and appropriate international organizations for comments.
2. To facilitate your review of the proposed amendment, the rationale for the proposal has been provided throughout Attachment A in the text boxes immediately following the relevant proposals.
3. The amendment proposals to Annex 14, Volume II address the second part of a two-part comprehensive review and updating of the document. As such there are multiple proposals covering various subjects, including definitions, heliport data, physical characteristics, obstacle restriction and removal and visual aids.
4. In examining the proposed amendment, you should not feel obliged to comment on editorial aspects as such matters will be addressed by the Air Navigation Commission during its final review of the draft amendment.
5. May I request that any comments you may wish to make on the proposed amendment to Annex 14, Volume II be dispatched to reach me not later than 31 July 2011. The Air Navigation Commission has asked me to specifically indicate that comments received after the due date may not be considered by the Commission and the Council. In this connection, should you anticipate a delay in the receipt of your reply, please let me know in advance of the due date.

6. For your information, the proposed amendment to Annex 14, Volume II is envisaged for applicability on 15 November 2012. Any comments you may have thereon would be appreciated.

7. The subsequent work of the Air Navigation Commission and the Council would be greatly facilitated by specific statements on the acceptability or otherwise of the amendment proposal.

8. Please note that, for the review of your comments by the Air Navigation Commission and the Council, replies are normally classified as “agreement with or without comments”, “disagreement with or without comments”, or “no indication of position”. If in your reply the expressions “no objections” or “no comments” are used, they will be taken to mean “agreement without comment” and “no indication of position”, respectively. In order to facilitate proper classification of your response, a form has been included in Attachment B, which may be completed and returned together with your comments, if any, on the proposals in Attachment A.

Accept, Sir/Madam, the assurances of my highest consideration.

A handwritten signature in black ink, appearing to read 'Raymond Benjamin', with a long, sweeping underline that extends to the right.

Raymond Benjamin  
Secretary General

**Enclosures:**

- A — Proposed amendment to Annex 14, Volume II
- B — Response Form

**ATTACHMENT A** to State letter AN 4/1.1.51-11/31

**PROPOSED AMENDMENT TO AERODROMES  
ANNEX 14, VOLUME II  
(HELIPORTS)**

**NOTES ON THE PRESENTATION OF THE PROPOSED AMENDMENT**

The text of the amendment is arranged to show deleted text with a line through it and new text highlighted with grey shading, as shown below:

1. ~~Text to be deleted is shown with a line through it.~~ text to be deleted
2. **New text to be inserted is highlighted with grey shading.** new text to be inserted
3. ~~Text to be deleted is shown with a line through it~~ followed by the **replacement text which is highlighted with grey shading.** new text to replace existing text

**ABBREVIATIONS AND SYMBOLS***(used in Annex 14, Volume II)**Abbreviations*

ASPSL	Arrays of segmented point source lighting
cd	Candela
cm	Centimetre
<del>D</del>	<del>Helicopter greatest overall dimension</del>
FATO	Final approach and take-off area
ft	Foot
GNSS	Global navigation satellite system
HAPI	Helicopter approach path indicator
HFM	Helicopter flight manual
Hz	Hertz
<del>IMC</del>	<del>Instrument meteorological conditions</del>
kg	Kilogram
km/h	Kilometre per hour
kt	Knot
L	Litre
lb	Pounds
LDAH	Landing distance available
L/min	Litre per minute
LOA	Limited obstacle area
LOS	Limited obstacle sector
LP	Luminescent panel
m	Metre
MAPt	Missed approach point
MTOM	Maximum take-off mass
OFS	Obstacle free sector
PinS	Point-in-space
<del>RD</del>	<del>Diameter of the largest rotor</del>
R/T	Radio Telephony or radio communications
RTODAH	Rejected take-off distance available
s	Second
SBAS	Satellite-based augmentation system
t	Metric tonne (1000 kg)
TLOF	Touchdown and lift-off area
TODAH	Take-off distance available
UCW	Undercarriage width
<del>VMC</del>	<del>Visual meteorological conditions</del>
VSS	Visual segment surface

*Symbols*

°	Degree
=	Equals
%	Percentage
±	Plus or minus

## INTERNATIONAL STANDARDS AND RECOMMENDED PRACTICES

### CHAPTER 1. GENERAL

*Introductory Note.— Annex 14, Volume II, contains Standards and Recommended Practices (specifications) that prescribe the physical characteristics and obstacle limitation surfaces to be provided for at heliports, and certain facilities and technical services normally provided at a heliport. It is not intended that these specifications limit or regulate the operation of an aircraft.*

*When designing a heliport, the critical design helicopter, having the largest set of dimensions and the greatest maximum take-off mass (MTOM) the heliport is intended to serve, would need to be considered.*

*It is to be noted that provisions for helicopter flight operations are contained in Annex 6, Part III.*

#### 1.1 Definitions

When the following terms are used in this volume, they have the meanings given below. Annex 14, Volume I, contains definitions for those terms which are used in both volumes.

**Accuracy.** A degree of conformance between the estimated or measured value and the true value.

*Note.— For measured positional data, the accuracy is normally expressed in terms of a distance from a stated position within which there is a defined confidence of the true position falling.*

~~**Air transit route.** A defined route for the air transiting of helicopters.~~

**Calendar.** Discrete temporal reference system that provides the basis for defining temporal position to a resolution of one day (ISO 19108<sup>\*</sup>).

**Cyclic redundancy check (CRC).** A mathematical algorithm applied to the digital expression of data that provides a level of assurance against loss or alteration of data.

**D.** The largest overall dimension of the helicopter when rotor(s) are turning measured from the most forward position of the main rotor tip path plane to the most rearward position of the tail rotor tip path plane or helicopter structure.

*Note.— “D” is sometimes referred to in the text using the terminology “D-value”.*

**Data quality.** A degree or level of confidence that the data provided meet the requirements of the data user in terms of accuracy, resolution and integrity.

---

<sup>\*</sup> ISO Standard 19108, *Geographic information — Temporal schema*

**Datum.** Any quantity or set of quantities that may serve as a reference or basis for the calculation of other quantities (ISO 19104\*\*).

**Declared distances — heliports.**

- a) *Take-off distance available (TODAH).* The length of the FATO plus the length of helicopter clearway (if provided) declared available and suitable for helicopters to complete the take-off.
- b) *Rejected take-off distance available (RTODAH).* The length of the FATO declared available and suitable for helicopters operated in performance class 1 to complete a rejected take-off.
- c) *Landing distance available (LDAH).* The length of the FATO plus any additional area declared available and suitable for helicopters to complete the landing manoeuvre from a defined height.

**Dynamic load-bearing surface.** A surface capable of supporting the loads generated by a helicopter conducting an emergency touchdown on it.

**Elevated heliport.** A heliport located on a raised structure ~~on land~~.

**Ellipsoid height (Geodetic height).** The height related to the reference ellipsoid, measured along the ellipsoidal outer normal through the point in question.

**FATO/TLOF.** Specific case where a FATO and a TLOF occupy the same space on an elevated heliport, a helideck or a shipboard heliport.

**Final approach and take-off area (FATO).** A defined area over which the final phase of the approach manoeuvre to hover or landing is completed and from which the take-off manoeuvre is commenced. Where the FATO is to be used by helicopters operated in performance class 1, the defined area includes the rejected take-off area available.

**Geodetic datum.** A minimum set of parameters required to define location and orientation of the local reference system with respect to the global reference system/frame.

**Geoid.** The equipotential surface in the gravity field of the Earth which coincides with the undisturbed mean sea level (MSL) extended continuously through the continents.

*Note.— The geoid is irregular in shape because of local gravitational disturbances (wind tides, salinity, current, etc.) and the direction of gravity is perpendicular to the geoid at every point.*

**Geoid undulation.** The distance of the geoid above (positive) or below (negative) the mathematical reference ellipsoid.

*Note.— In respect to the World Geodetic System — 1984 (WGS-84) defined ellipsoid, the difference between the WGS-84 ellipsoidal height and orthometric height represents WGS-84 geoid undulation.*

**Gregorian calendar.** Calendar in general use; first introduced in 1582 to define a year that more closely approximates the tropical year than the Julian calendar (ISO 19108\*\*\*).

---

\*\* ISO Standard 19104, *Geographic information — Terminology*

*Note.*— In the Gregorian calendar, common years have 365 days and leap years 366 days divided into twelve sequential months.

**Helicopter air taxiway.** A defined path on the surface established for the air taxiing of helicopters.

**Helicopter clearway.** A defined area on the ground or water, selected and/or prepared as a suitable area over which a helicopter operated in performance class 1 may accelerate and achieve a specific height.

**Helicopter ground taxiway.** A ground taxiway intended for the ground movement of wheeled undercarriage helicopters.

**Helicopter stand.** An aircraft stand which provides for parking a helicopter and where ground taxi operations are completed or where the helicopter touches down and lifts off for air taxi operations.

**Helicopter taxi-route.** A defined path established for the movement of helicopters from one part of a heliport to another. A taxi-route includes a helicopter air or ground taxiway which is centred on the taxi-route.

**Helideck.** A heliport located on an fixed or floating offshore structure—facility such as an exploration and/or production platform—unit used for the exploitation of oil or gas.

**Heliport.** An aerodrome or a defined area on a structure intended to be used wholly or in part for the arrival, departure and surface movement of helicopters.

**Heliport elevation.** The elevation of the highest point of the FATO expressed as the distance above mean sea level.

**Integrity (aeronautical data).** A degree of assurance that an aeronautical data and its value has not been lost nor altered since the data origination or authorized amendment.

**Obstacle.** All fixed (whether temporary or permanent) and mobile objects, or parts thereof, that:

- a) are located on an area intended for the surface movement of aircraft; or
- b) extend above a defined surface intended to protect aircraft in flight; or
- c) stand outside those defined surfaces and that have been assessed as being a hazard to air navigation.

**Orthometric height.** Height of a point related to the geoid, generally presented as an MSL elevation.

**Point-in-space approach (PinS).** The Point-in-space approach is based on GNSS or SBAS and is an approach procedure designed for helicopters only. It is aligned with a reference point located to permit subsequent flight manoeuvring or approach and landing using visual manoeuvring in adequate visual conditions to see and avoid obstacles.

**Point-in-space (PinS) visual segment.** This is the segment of a helicopter PinS approach procedure from the MAPt to the landing location for a PinS “proceed visually” procedure. The visual segment connects the Point-in-space (PinS) to the landing location.

**Protection area.** An area within a taxi-route and around a helicopter stand which provides separation from objects, the FATO, other taxi-routes and helicopter stands, for safe manoeuvring of helicopters.

**Rejected take-off area.** A defined area on a heliport suitable for helicopters operating in performance class 1 to complete a rejected take-off.

**Runway-type FATO.** A FATO having characteristics similar in shape to a runway.

**Safety area.** A defined area on a heliport surrounding the FATO which is free of obstacles, other than those required for air navigation purposes, and intended to reduce the risk of damage to helicopters accidentally diverging from the FATO.

**Shipboard heliport.** A heliport located on a ship that may be purpose or non-purpose-built. A purpose-built shipboard heliport is one designed specifically for helicopter operations. A non-purpose-built shipboard heliport is one that utilizes an area of the ship that is capable of supporting a helicopter but not designed specifically for that task.

**Static load-bearing surface.** A surface capable of supporting the mass of a helicopter situated upon it.

**Station declination.** An alignment variation between the zero degree radial of a VOR and true north, determined at the time the VOR station is calibrated.

**Surface-level heliport.** A heliport located on the ground or on a structure on the surface of the water.

~~**Taxi-route.** A defined path established for the movement of helicopters from one part of a heliport to another. A taxi route includes a helicopter air or ground taxiway which is centred on the taxi route.~~

**Touchdown and lift-off area (TLOF).** An area on which a helicopter may touch down or lift off.

**Winching area.** An area provided for the transfer by helicopter of personnel or stores to or from a ship.

## 1.2 Applicability

*Note.— The dimensions discussed in this Annex are based on consideration of single-main-rotor helicopters. For tandem-rotor helicopters the heliport design will be based on a case-by-case review of the specific models using the basic requirement for a safety area and protection areas specified in this Annex. The specifications of the main chapters of this Annex are applicable for visual heliports that may or may not incorporate the use of a Point-in-space approach. Additional specifications for instrument heliports with non-precision and/or precision approaches and instrument departures are detailed in Appendix 2. The specifications of this Annex are not applicable for water heliports.*

1.2.1 The interpretation of some of the specifications in the Annex expressly requires the exercising of discretion, the taking of a decision or the performance of a function by the appropriate authority. In other specifications, the expression appropriate authority does not actually appear although its inclusion is implied. In both cases, the responsibility for whatever determination or action is necessary shall rest with the State having jurisdiction over the heliport.

1.2.2 The specifications in Annex 14, Volume II, shall apply to all heliports intended to be used by helicopters in international civil aviation. They shall apply equally to areas for the exclusive use of helicopters at an aerodrome primarily meant for the use of aeroplanes. Where relevant, the provisions of Annex 14, Volume I, shall apply to the helicopter operations being conducted at such an aerodrome.

1.2.3 Unless otherwise specified, the specification for a colour referred to within this volume shall be that contained in Appendix 1 to Annex 14, Volume I.

## CHAPTER 2. HELIPORT DATA

### 2.3 Heliport elevation

2.3.1 The heliport elevation and geoid undulation at the heliport elevation position shall be measured and reported to the aeronautical information services authority to the accuracy of one-half metre or foot.

2.3.2 ~~For a heliport used by international civil aviation, t~~ The elevation of the TLOF and/or the elevation and geoid undulation of each threshold of the FATO (where appropriate) shall be measured and reported to the aeronautical information services authority to the accuracy of one half metre or foot;

- ~~a) one half metre or foot for non-precision approaches; and~~
- ~~b) one quarter metre or foot for precision approaches.~~

*Note.— Geoid undulation must be measured in accordance with the appropriate system of coordinates.*

### 2.4 Heliport dimensions and related information

2.4.1 The following data shall be measured or described, as appropriate, for each facility provided on a heliport:

- a) heliport type — surface-level, elevated, shipboard or helideck;
- b) TLOF — dimensions to the nearest metre or foot, slope, surface type, bearing strength in tonnes (1 000 kg);

- c) ~~FATO final approach and take-off area~~ — type of FATO, true bearing to one-hundredth of a degree, designation number (where appropriate), length, ~~and~~ width to the nearest metre or foot, slope, surface type;
- d) safety area — length, width and surface type;
- e) helicopter ground taxiway, ~~and~~ air taxiway ~~and air transit route~~ — designation, width, surface type;
- f) apron — surface type, helicopter stands;
- g) clearway — length, ground profile;
- h) visual aids for approach procedures, marking and lighting of FATO, TLOF, taxiways and ~~helicopter stands~~ ~~aprons~~; and
- i) ~~distances to the nearest metre or foot of localizer and glide path elements comprising an instrument landing system (ILS) or azimuth and elevation antenna of a microwave landing system (MLS) in relation to the associated TLOF or FATO extremities.~~

2.4.2 The geographical coordinates of the geometric centre of the TLOF and/or of each threshold of the FATO (where appropriate) shall be measured and reported to the aeronautical information services authority in degrees, minutes, seconds and hundredths of seconds.

2.4.3 The geographical coordinates of appropriate centre line points of helicopter ground taxiways, and air taxiways ~~and air transit routes~~ shall be measured and reported to the aeronautical information services authority in degrees, minutes, seconds and hundredths of seconds.

2.4.4 The geographical coordinates of each helicopter stand shall be measured and reported to the aeronautical information services authority in degrees, minutes, seconds and hundredths of seconds.

2.4.5 The geographical coordinates of obstacles in Area 2 (the part within the heliport boundary) and in Area 3 shall be measured and reported to the aeronautical information services authority in degrees, minutes, seconds and tenths of seconds. In addition, the top elevation, type, marking and lighting (if any) of obstacles shall be reported to the aeronautical information services authority.

*Note 1.— See Annex 15, Appendix 8, for graphical illustrations of obstacle data collection surfaces and criteria used to identify obstacles in Areas 2 and 3.*

*Note 2.— Appendix 1 to this Annex provides requirements for obstacle data determination in Areas 2 and 3.*

*Note 3.— Implementation of Annex 15, provision 10.6.1.2, concerning the availability, as of 18 November 2010, of obstacle data according to Area 2 and Area 3 specifications would be facilitated by appropriate advance planning for the collection and processing of such data.*

*Rationale*

Instrument heliport requirements have been moved to Appendix 2, thus only leaving non-instrument criteria which has been standardized at one half metre or foot for measurement accuracy.

### CHAPTER 3. PHYSICAL CHARACTERISTICS

#### 3.1 Surface-level heliports

*Note 1.— The following specifications are for land based heliports only. Where a water heliport is being considered, the appropriate authority may establish suitable criteria.*

*Note 2.— The dimensions of the taxi routes and helicopter stands include a protection area.*

*Note 1.— The provisions given in this section are based on the design assumption that no more than one helicopter will be in the FATO at the same time.*

*Note 2.— The design provisions given in this section assume when conducting operations to a FATO in proximity to another FATO, these operations will not be simultaneous. If simultaneous helicopter operations are required, appropriate separation distances between FATOs need to be determined, giving due regard to such issues as rotor downwash and airspace, and ensuring the flight paths for each FATO, defined in Chapter 4, do not overlap.*

*Note 3.— The specifications for ground taxi-routes and air taxi-routes are intended for the safety of simultaneous operations during the manoeuvring of helicopters. However, the wind velocity induced by the rotor downwash might have to be considered.*

#### **Final approach and take-off areas**

3.1.1 A surface-level heliport shall be provided with at least one final approach and take-off area (FATO).

*Note.— A FATO may be located on or near a runway strip or taxiway strip.*

3.1.2 A FATO shall be obstacle free.

3.1.3 The dimensions of a FATO shall be:

- a) where intended to be used by helicopters operated in performance class 1, as prescribed in the helicopter flight manual (HFM) except that, in the absence of width specifications, the width shall be not less than the greatest overall dimension (D) of the largest helicopter the FATO is intended to serve;

- b) where intended to be used by helicopters operated in performance class 2 or 3, of sufficient size and shape to contain an area within which can be drawn a circle of diameter not less than:
- 1) 1 D of the largest helicopter when the maximum take-off mass (MTOM) of helicopters the FATO is intended to serve is more than 3 175 kg;
  - 2) 0.83 D of the largest helicopter when the MTOM of helicopters the FATO is intended to serve is 3 175 kg or less.

*Note.*— Where the term FATO is not used in the HFM, the minimum landing/take-off area specified in the HFM for the appropriate flight profile is used.

**3.1.4 Recommendation.**— Where intended to be used by helicopters operated in performance class 2 or 3 with MTOM of 3 175 kg or less, the FATO should be of sufficient size and shape to contain an area within which can be drawn a circle of diameter not less than 1 D.

*Note.*— Local conditions, such as elevation and temperature, may need to be considered when determining the size of a FATO. Guidance is given in the Heliport Manual (Doc 9261).

**3.1.5** The FATO shall provide rapid drainage but the mean slope in any direction on the FATO shall not exceed 3 per cent. No portion of a FATO shall have a local slope exceeding:

- a) 5 per cent where the heliport is intended to be used by helicopters operated in performance class 1; and
- b) 7 per cent where the heliport is intended to be used by helicopters operated in performance class 2 or 3.

**3.1.6** The surface of the FATO shall:

- a) be resistant to the effects of rotor downwash;
- b) be free of irregularities that would adversely affect the take-off or landing of helicopters; and
- c) have bearing strength sufficient to accommodate a rejected take-off by helicopters operated in performance class 1.

**3.1.7** The surface of a FATO surrounding a touchdown and lift-off area (TLOF) intended for use by helicopters operated in performance classes 2 and 3 shall be static load-bearing.

**3.1.8 Recommendation.**— The FATO should provide ground effect.

**3.1.9 Recommendation.**— The FATO should be located so as to minimize the influence of the surrounding environment, including turbulence, which could have an adverse impact on helicopter operations.

*Note.*— Guidance on determining the influence of turbulence is given in the Heliport Manual (Doc 9261). If turbulence mitigating design measures are warranted but not practical, operational limitations may need to be considered under certain wind conditions.

### **Helicopter clearways**

*Note.*— A helicopter clearway would need to be considered when the heliport is intended to be used by helicopters operating in performance class 1. See Heliport Manual (Doc 9261).

3.1.9~~10~~ When a helicopter clearway is provided, it shall be located beyond the end of the rejected take-off area available FATO.

3.1.4~~11~~ **Recommendation.**— The width of a helicopter clearway should not be less than that of the associated safety area (see Figure 3-1).

3.1.4~~12~~ **Recommendation.**— The ground in a helicopter clearway should not project above a plane having an upward slope of 3 per cent, the lower limit of this plane being a horizontal line which is located on the periphery of the FATO.

3.1.4~~13~~ **Recommendation.**— An object situated ~~on~~ in a helicopter clearway, which may endanger helicopters in the air, should be regarded as an obstacle and should be removed.

### **Touchdown and lift-off areas**

3.1.4~~3~~14 At least one TLOF shall be provided at a heliport.

3.1.15 One TLOF shall be located within the FATO or one or more TLOFs shall be collocated with helicopter stands. For runway-type FATOs, additional TLOFs located in the FATO are acceptable. For further guidance see Heliport Manual (Doc 9261).

*Note 1.*— The TLOF may or may not be located within the FATO.

*Note 2.*— Additional TLOFs may be collocated with helicopter stands.

3.1.4~~4~~16 The TLOF shall be of sufficient size to contain a circle of diameter of at least 0.83 D of the largest helicopter the area is intended to serve.

*Note.*— A TLOF may be any shape.

3.1.4~~5~~17 Slopes on a TLOF shall be sufficient to prevent accumulation of water on the surface of the area, but shall not exceed 2 per cent in any direction.

3.1.4~~6~~18 Where the TLOF is within the FATO, the TLOF shall be dynamic load-bearing.

3.1.4~~7~~19 Where a TLOF is collocated with a helicopter stand, the TLOF shall be static load-bearing and be capable of withstanding the traffic of helicopters that the area is intended to serve.

3.1.4~~8~~20 Where ~~the~~ a TLOF is located within ~~the~~ a FATO which can contain a circle of diameter more than 1 D, the centre of the TLOF shall be located not less than 0.5 D from the edge of the FATO.

**Safety areas**

3.1.19~~21~~ A FATO shall be surrounded by a safety area which need not be solid.

3.1.20~~22~~ A safety area surrounding a FATO ~~intended to be used by helicopters operated in performance class 1 in visual meteorological conditions (VMC)~~ shall extend outwards from the periphery of the FATO for a distance of at least 3 m or 0.25 D, whichever is greater, of the largest helicopter the FATO is intended to serve and:

- a) each external side of the safety area shall be at least 2 D where the FATO is quadrilateral; or
- b) the outer diameter of the safety area shall be at least 2 D where the FATO is circular.

(See Figure 3-1.)

~~3.1.21 A safety area surrounding a FATO intended to be used by helicopters operated in performance class 2 or 3 in visual meteorological conditions (VMC) shall extend outwards from the periphery of the FATO for a distance of at least 3 m or 0.5 D, whichever is greater, of the largest helicopter the FATO is intended to serve and:~~

- ~~a) each external side of the safety area shall be at least 2 D where the FATO is quadrilateral; or~~
- ~~b) the outer diameter of the safety area shall be at least 2 D where the FATO is circular.~~

3.1.22~~23~~ There shall be a protected side slope rising at 45 degrees from the edge of the safety area to a distance of 10 m, whose surface shall not be penetrated by obstacles, except that when obstacles are located to one side of the FATO only, they may be permitted to penetrate the side slope surface.

*Note.— When only a single approach and take-off climb surface is provided, the need for specific protected side slopes would be addressed in the aeronautical study required in 4.2.7.*

~~3.1.23 A safety area surrounding a FATO intended to be used by helicopter operations in instrument meteorological conditions (IMC) shall extend:~~

- ~~a) laterally to a distance of at least 45 m on each side of the centre line; and~~
- ~~b) longitudinally to a distance of at least 60 m beyond the ends of the FATO.~~

(See Figure 3-1.)

3.1.24 No fixed **raised** object shall be permitted on a safety area, except for frangible objects, which, because of their function, must be located on the area. No mobile object shall be permitted on a safety area during helicopter operations.

~~3.1.25 Objects whose functions require them to be located on the safety area shall not exceed a height of 25 cm when located along the edge of the FATO nor penetrate a plane originating at a height of 25 cm above the edge of the FATO and sloping upwards and outwards from the edge of the FATO at a gradient of 5 per cent.~~

**3.1.25 Objects whose function requires them to be located on the safety area shall not:**

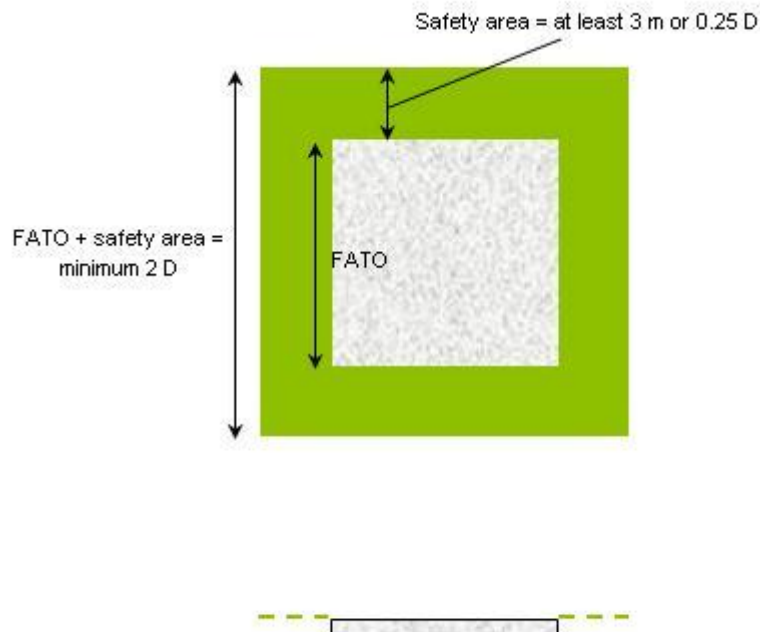
- a) if located at a distance of less than  $0.75 D$  from the centre of the FATO, penetrate a plane at a height of 5 cm above the plane of the FATO; and
- b) if located at a distance of  $0.75 D$  or more from the centre of the FATO, penetrate a plane originating at a height of 25 cm above the plane of the FATO and sloping upwards and outwards at a gradient of 5 per cent.

**3.1.26 Recommendation.** ~~In the case of a FATO of diameter less than  $1 D$ , the maximum height of the objects whose functions require them to be located on the safety area should not exceed a height of 5 cm.~~

---

*Editorial Note.*— Replace Figure 3-1 with new Figure 3-1 as follows:  
(existing Figure 3-1 is relocated to Appendix 2 Figure A3-1)

---



**Figure 3-1. FATO and associated safety area**

**3.1.2726** The surface of the safety area, when solid, shall not exceed an upward slope of 4 per cent outwards from the edge of the FATO.

3.1.2827 Where applicable, the surface of the safety area shall be treated to prevent flying debris caused by rotor downwash.

3.1.2928 When solid, the surface of the safety area abutting the FATO shall be continuous with the FATO.

### **Helicopter ground taxiways and ground taxi-routes**

*Note 1.— A helicopter ground taxiway is intended to permit the surface movement of a wheeled helicopter under its own power.*

*Note 2.— The following specifications are intended for the safety of simultaneous operations during the manoeuvring of helicopters. However, the wind velocity induced by the rotor downwash might have to be considered.*

*Note 3.— When a taxiway is intended for use by aeroplanes and helicopters, the provisions for taxiways for aeroplanes and helicopter ground taxiways will be taken into consideration and the more stringent requirements will be applied.*

3.1.3029 The width of a helicopter ground taxiway shall not be less than 1.5 times the largest width of the undercarriage (UCW) of the helicopters the ground taxiway is intended to serve (see Figure 3-2).

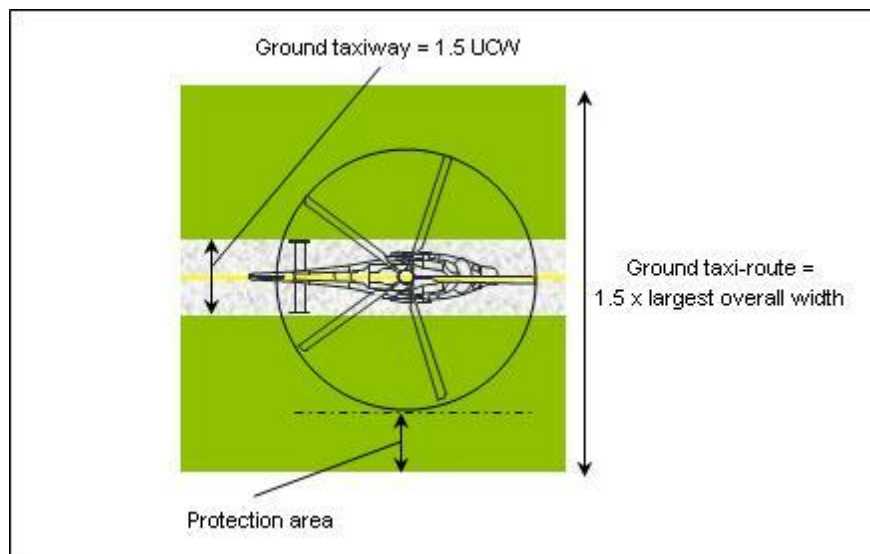
3.1.3130 The longitudinal slope of a helicopter ground taxiway shall not exceed 3 per cent.

3.1.3231 A helicopter ground taxiway shall be static load-bearing and be capable of withstanding the traffic of the helicopters the helicopter ground taxiway is intended to serve.

---

*Editorial Note.—* Replace Figure 3-2 with new Figure 3-2 as follows:

---



**Figure 3-2. Helicopter ground taxi-route/taxiway**

3.1.33~~32~~ A helicopter ground taxiway shall be centred on a ground taxi-route.

3.1.34~~33~~ A helicopter ground taxi-route shall extend symmetrically on each side of the centre line for at least 0.75 times the largest overall width of the helicopters it is intended to serve.

3.1.35~~34~~ No **fixed raised** objects shall be permitted on a helicopter ground taxi-route, except for frangible objects, which, because of their function, must be located thereon. **No mobile object shall be permitted on a ground taxi-route during helicopter movements.**

3.1.35 Objects whose function requires them to be located on a helicopter ground taxi-route shall not:

a) be located at a distance of less than 50 cm from the edge of the helicopter ground taxiway; and

b) penetrate a plane originating at a height of 25 cm above the plane of the taxiway, at a distance of 50 cm from the edge of the taxiway and sloping upwards and outwards at a gradient of 5 per cent.

3.1.36 The helicopter ground taxiway and the ground taxi-route shall provide rapid drainage but the helicopter ground taxiway transverse slope shall not exceed 2 per cent.

3.1.37 The surface of a helicopter ground taxi-route shall be resistant to the effect of rotor downwash.

3.1.38 For simultaneous operations, the helicopter ground taxi-routes shall not overlap.

### ***Helicopter air taxiways and air taxi-routes***

*Note.*— A helicopter air taxiway is intended to permit the movement of a helicopter above the surface at a height normally associated with ground effect and at ground speed less than 37km/h (20 kt).

3.1.38~~39~~ The width of a helicopter air taxiway shall be at least two times the largest width of the undercarriage (UCW) of the helicopters that the air taxiway is intended to serve (see Figure 3-3).

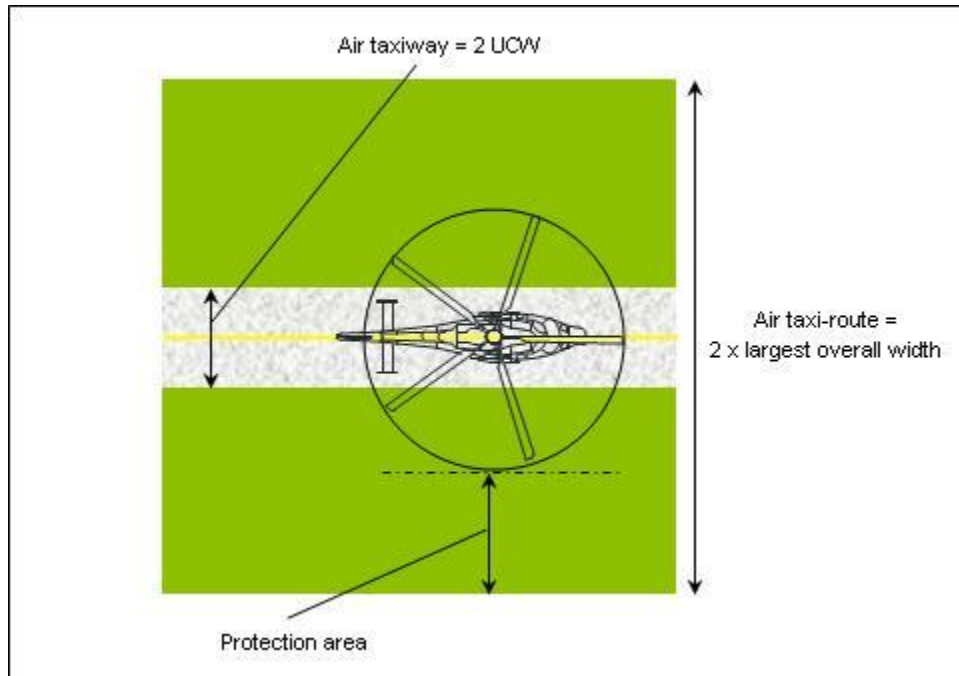
~~3.1.39—The surface of a helicopter air taxiway shall be suitable for an emergency landing.~~

3.1.40 **Recommendation.**— *The surface of a helicopter air taxiway should be static load-bearing.*

---

**Editorial Note.**— Replace Figure 3-3 with new Figure 3-3 as follows:

---



**Figure 3-3. Helicopter air taxi-route/taxiway**

3.1.41 **Recommendation.**— *The ~~transverse slopes~~ of the surface of a helicopter air taxiway should not exceed the slope landing limitations of the helicopters the air taxiway is intended to serve. In any event the transverse slope should not exceed 10 per cent and the longitudinal slope should not exceed 7 per cent. In any event, the slopes should not exceed the slope landing limitations of the helicopters the air taxiway is intended to serve.*

3.1.42 A helicopter air taxiway shall be centred on an air taxi-route.

3.1.43 A helicopter air taxi-route shall extend symmetrically on each side of the centre line for a distance at least equal to the largest overall width of the helicopters it is intended to serve.

3.1.44 No **fixed raised** objects shall be permitted on an air taxi-route, except for frangible objects, which, because of their function, must be located thereon. **No mobile object shall be permitted on an air taxi-route during helicopter movements.**

3.1.45 **Objects whose function requires them to be located on an air taxi-route shall not:**

- a) be located at a distance of less than 1 m from the edge of the air taxiway; and
- b) penetrate a plane originating at a height of 25 cm above the plane of the taxiway, at a distance of 1 m from the edge of the taxiway and sloping upwards and outwards at a gradient of 5 per cent.

3.1.46 **Recommendation.**— *Objects whose function requires them to be located on an air taxi-route should not:*

- a) be located at a distance of less than 0.5 of the largest overall width of the helicopter for which the

*air taxi-route is designed from the centre line of the air taxiway; and*

- b) *penetrate a plane originating at a height of 25 cm above the plane of the taxiway, at a distance of 0.5 of the largest overall width of the helicopter for which the air taxi-route is designed from the centre line of the taxiway, and sloping upwards and outwards at a gradient of 5 per cent.*

3.1.45<sup>47</sup> The surface of an air taxi-route shall be resistant to the effect of rotor downwash.

3.1.46<sup>48</sup> The surface of an air taxi-route shall provide ground effect.

3.1.49 For simultaneous operations, the air taxi-routes shall not overlap.

### ***Air transit route***

~~——— Note. — An air transit route is intended to permit the movement of a helicopter above the surface, normally at heights not above 30 m (100 ft) above ground level and at ground speeds exceeding 37 km/h (20 kt).~~

~~——— 3.1.47 The width of an air transit route shall not be less than:~~

- ~~—— a) 7.0 times the largest overall width of the helicopters the air transit route is intended to serve when the air transit route is intended for use by day only; and~~
- ~~—— b) 10.0 times the largest overall width of the helicopters the air transit route is intended to serve when the air transit route is intended for use at night.~~

~~——— 3.1.48 Any variation in the direction of the centre line of an air transit route shall not exceed 120 degrees and be designed so as not to necessitate a turn of radius less than 270 m.~~

~~——— Note. — It is intended that air transit routes be selected so as to permit autorotative or one-engine inoperative landings such that, as a minimum requirement, injury to persons on the ground or water, or damage to property are minimized.~~

### ***Aprons Helicopter stands***

*Note. — The provisions of this section do not specify the location for helicopter stands but allow a high degree of flexibility in the overall design of the heliport. However, it is not considered good practice to locate helicopter stands under a flight path. See Heliport Manual (Doc 9261) for further guidance.*

3.1.50 When a TLOF is collocated with a helicopter stand, the protection area of the stand shall not overlap the protection area of any other helicopter stand or associated taxi route.

3.1.49<sup>51</sup> The helicopter stand shall provide rapid drainage but the slope in any direction on a helicopter stand shall not exceed 2 per cent.

*Note. — The requirements on the dimensions of helicopter stands assume the helicopter will turn in a hover when operating over a stand.*

3.1.50~~52~~ A helicopter stand intended to be used by helicopters turning in a hover shall be of sufficient size to contain a circle of diameter of at least 1.2 D of the largest helicopter the stand is intended to serve (see Figure 3-4).

3.1.51~~53~~ ~~When~~ Where a helicopter stand is intended to be used for taxi-through and where the helicopter using the stand is not required to turn, the minimum width of the stand and associated protection area shall be that of the taxi-route (see Figure 3-4).

3.1.52~~54~~ ~~When~~ Where a helicopter stand is intended to be used for turning, the minimum dimension of the stand and protection area shall be not less than 2 D (see Figure 3-5).

3.1.53~~55~~ ~~When~~ Where a helicopter stand is intended to be used for turning, it shall be surrounded by a protection area which extends for a distance of 0.4 D from the edge of the helicopter stand.

---

*Editorial Note.*— Delete Figure 3-4.

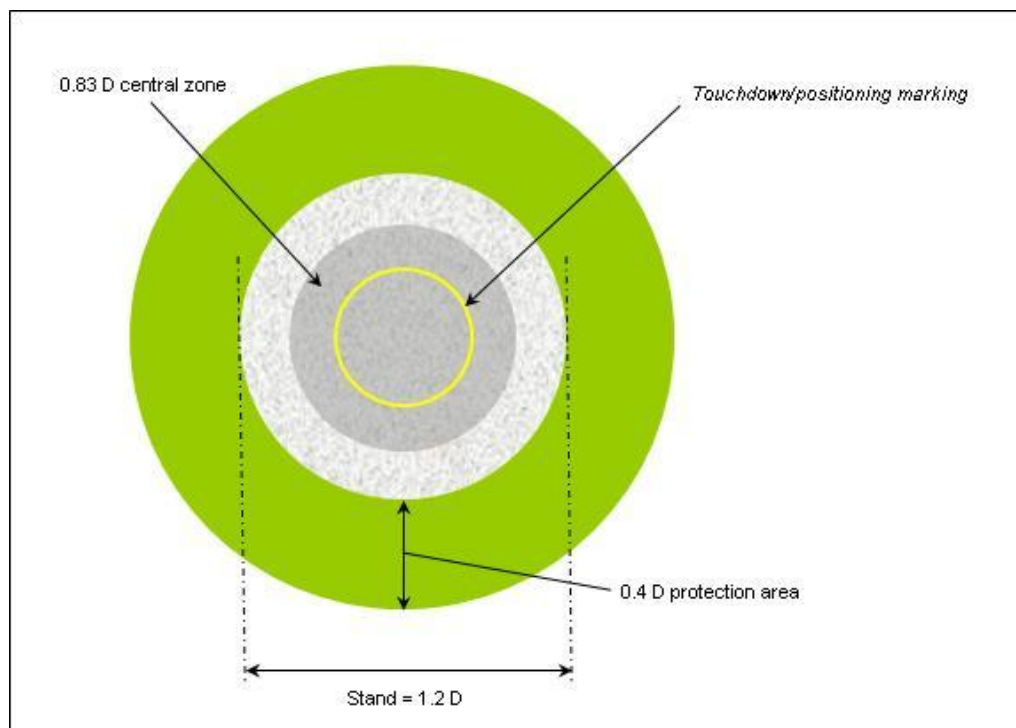
---



---

*Editorial Note.*— Replace Figure 3-5 with new Figure 3-4 as follows:

---



**Figure 3-4. Helicopter stand and associated protection area**

3.1.54~~56~~ For simultaneous operations, the protection areas of helicopter stands and their associated taxi-routes shall not overlap (see Figure 3-~~65~~).

*Note.— Where non-simultaneous operations are envisaged, the protection areas of helicopter stands and their associated taxi-routes may overlap (see Figure 3-~~76~~).*

~~3.1.55— When intended to be used for ground taxi operations by wheeled helicopters, the dimensions of a helicopter stand shall take into account the minimum turn radius of wheeled helicopters the stand is intended to serve.~~

3.1.56~~57~~ A helicopter stand and associated protection area intended to be used for air taxiing shall provide ground effect.

3.1.57~~58~~ No fixed raised objects shall be permitted on a helicopter stand and the associated protection area.

3.1.59 No fixed raised object shall be permitted in the protection area around a helicopter stand except for frangible objects, which because of their function, must be located there.

3.1.60 No mobile object shall be permitted on a helicopter stand and the associated protection area during helicopter movements.

3.1.61 Objects whose function requires them to be located in the protection area shall not:

- a) if located at a distance of less than 0.75 D from the centre of the helicopter stand, penetrate a plane at a height of 5 cm above the plane of the central zone; and
- b) if located at distance of 0.75 D or more from the centre of the helicopter stand, penetrate a plane at a height of 25 cm above the plane of the central zone and sloping upwards and outwards at a gradient of 5 per cent.

3.1.58~~62~~ The central zone of the a helicopter stand shall be capable of withstanding the traffic of helicopters that it is intended to serve and have a static load-bearing area:

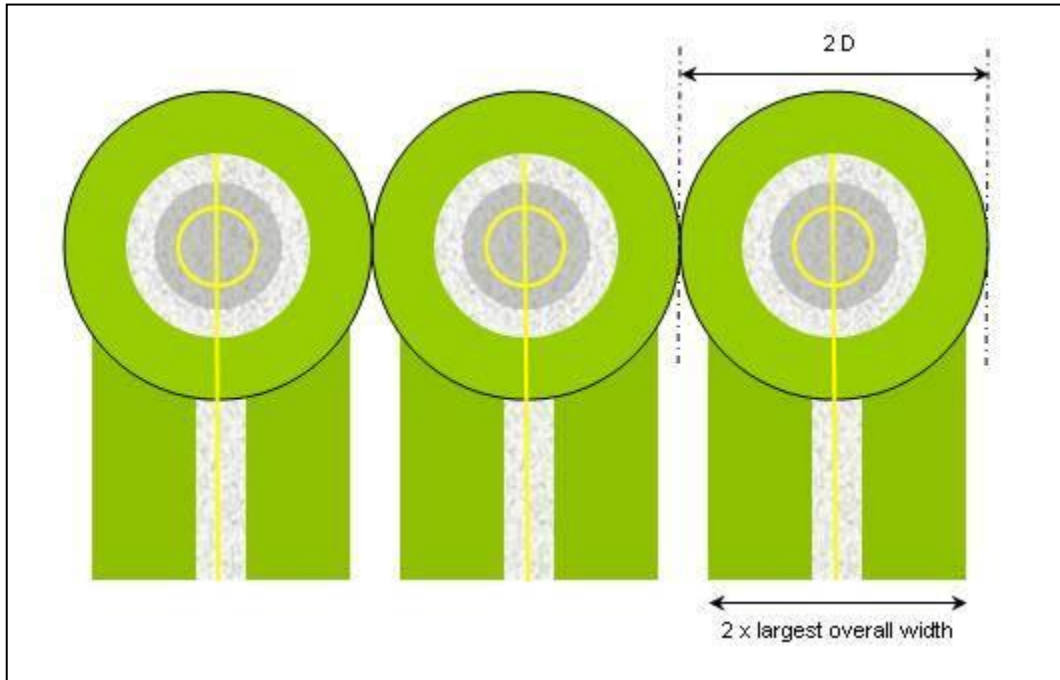
- a) of diameter not less than 0.83 D of the largest helicopter it is intended to serve; or
- b) for a helicopter stand intended to be used for ground taxi-through, and where the helicopter using the stand is not required to turn, the same width as the ground-taxiway.

*Note.— For a helicopter stand intended to be used for turning on the ground by wheeled helicopters, the dimension of the helicopter stand, including the dimension of the central zone, would may need to be significantly increased. See Heliport Manual (Doc 9261) for further guidance.*

---

*Editorial Note.— Replace Figure 3-6 with new Figure 3-5 as follows:*

---

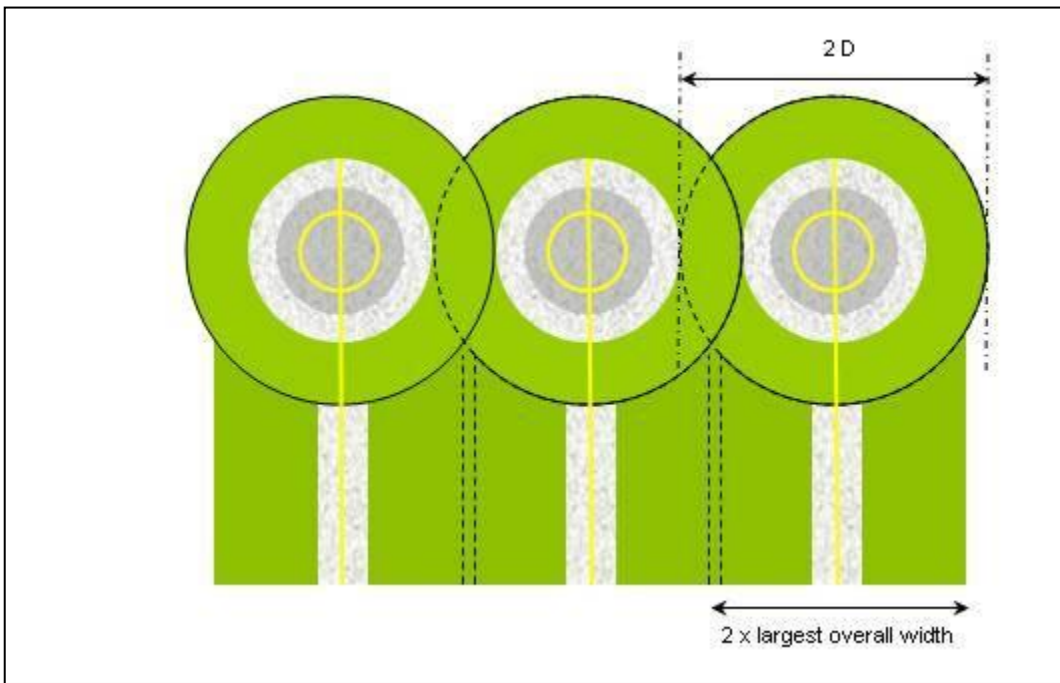


**Figure 3-5. Helicopter stands designed for hover turns with air taxi-routes/taxiways — simultaneous operations**

---

*Editorial Note.*— Replace Figure 3-7 with new Figure 3-6 as follows:

---



**Figure 3-6. Helicopter stands designed for hover turns with**

**air taxi-routes/taxiways — non-simultaneous operations*****Location of a final approach and take-off area  
in relation to a runway or taxiway***

3.1.59~~63~~ Where a FATO is located near a runway or taxiway, and ~~where~~ simultaneous ~~VMC~~ operations are planned, the separation distance between the edge of a runway or taxiway and the edge of a FATO shall not be less than the appropriate dimension in Table 3-1.

3.1.60~~64~~ **Recommendation.**— *A FATO should not be located:*

- a) *near taxiway intersections or holding points where jet engine efflux is likely to cause high turbulence; or*
- b) *near areas where aeroplane vortex wake generation is likely to exist.*

***Rationale***

A recommendation and a note are added to address the need to consider the influence of the surrounding environment, including turbulence effects. Lack of any specific location considerations in the past has sometimes led to heliport operations being restricted or limited, perhaps for the entire operating life of the facility, due to the adverse influence of the surrounding environment.

The standard relating to the height of objects permitted on the safety area is made more demanding to better ensure the safety of helicopter operations over the FATO. It is intended to better protect helicopters from the risk of inadvertent strikes with essential fixtures that may need to be so located close to the edge of the FATO, such as FATO perimeter lights; small helicopters can be specifically endangered by an obstacle strike.

The standards relating to objects on helicopter ground and air taxi-routes more precisely describe the objects permitted by taking into account their distance to the associated taxiway (edge or centre). They are intended to better protect helicopters from the risk of inadvertent strikes with essential fixtures that may need to be so located close to the edges of the taxiway, such as taxiway edge lights; small helicopters can be specifically endangered by an obstacle strike.

The standards relating to objects on helicopter stands more precisely describe the objects permitted on stands by taking into account their distance to the centre of the stand. It is consistent with a similar requirement for the height of objects permitted on the safety area and is intended to allow essential fixtures that may need to be so located on the protection area, with a combination of height and proximity to the stand that ensure the safety of helicopters.

### 3.2 Elevated heliports

*Note 1.—The dimensions of the taxi routes and helicopter stands include a protection area.*

*Note 2~~1~~.*— Guidance on structural design for elevated heliports is given in the Heliport Manual (Doc 9261).

*Note 2.— On elevated heliports it is presumed that the FATO and TLOF will be coincidental. Such an area, of which there may be one or more at an elevated heliport, is referred to as a “FATO/TLOF” in this section.*

*Note 3.— The provisions given in this section are based on the design assumption that no more than one helicopter will be in the FATO/TLOF at the same time.*

*Note 4.— The design provisions given in this section assume when conducting operations to a FATO/TLOF in proximity to another FATO/TLOF, these operations will not be simultaneous. If simultaneous helicopter operations are required, appropriate separation distances between FATO/TLOFs need to be determined, giving due regard to such issues as rotor downwash and airspace, and ensuring the flight paths for each FATO/TLOF, defined in Chapter 4, do not overlap.*

*Note 5.— The specifications for ground taxi-routes and air taxi-routes are intended for the safety of simultaneous operations during the manoeuvring of helicopters. However, the wind velocity induced by the rotor downwash might have to be considered.*

3.2.1 In the case of elevated heliports, design considerations of the different elements of the heliport shall take into account additional loading resulting from the presence of personnel, snow, freight, refuelling, fire fighting equipment, etc.

#### ***Final approach and take-off areas and touchdown and lift-off areas***

*Note.— On elevated heliports it is presumed that the FATO and one TLOF will be coincidental.*

3.2.2 An elevated heliport shall be provided with **at least** one FATO/TLOF.

3.2.3 A FATO/TLOF shall be obstacle free.

3.2.4 The dimensions of the FATO/TLOF shall be:

- a) where intended to be used by helicopters operated in performance class 1, as prescribed in the helicopter flight manual (HFM) except that, in the absence of width specifications, the width shall be not less than 1 D of the largest helicopter the FATO/TLOF is intended to serve;
- b) where intended to be used by helicopters operated in performance class 2 or 3, of sufficient size and shape to contain an area within which can be drawn a circle of diameter not less than:

- 1) 1 D of the largest helicopter when the MTOM of helicopters the FATO/TLOF is intended to serve is more than 3 175 kg;
- 2) 0.83 D of the largest helicopter when the MTOM of helicopters the FATO/TLOF is intended to serve is 3 175 kg or less.

3.2.5 **Recommendation.**— *Where intended to be used by helicopters operated in performance class 2 or 3 with MTOM of 3 175 kg or less, the FATO/TLOF should be of sufficient size and shape to contain an area within which can be drawn a circle of diameter not less than 1 D.*

*Note.*— *Local conditions, such as elevation and temperature, may need to be considered when determining the size of a FATO/TLOF. Guidance is given in the Heliport Manual (Doc 9261).*

3.2.6 Slopes on a the FATO/TLOF at an elevated heliport shall be sufficient to prevent accumulation of water on the surface of the area, but shall not exceed 2 per cent in any direction.

3.2.7 The FATO/TLOF shall be dynamic load-bearing.

3.2.8 The surface of the FATO/TLOF shall be:

- a) resistant to the effects of rotor downwash; and
- b) free of irregularities that would adversely affect the take-off or landing of helicopters.

3.2.9 **Recommendation.**— *The FATO/TLOF should provide ground effect.*

3.2.10 Safety devices such as safety nets or safety shelves shall be located around the edge of an elevated heliport but shall not exceed the FATO/TLOF height.

3.2.11 **Recommendation.**— *The FATO/TLOF should be located so as to minimize the influence of the surrounding environment, including turbulence, which could have an adverse impact on helicopter operations.*

*Note.*— *Specific guidance to determine if an air-gap under the heliport and/or some other turbulence mitigating design measure is necessary is given in the Heliport Manual (Doc 9261). If turbulence mitigating design measures are warranted but not practical, operational limitations may need to be considered under certain wind conditions.*

### ***Helicopter clearways***

a) —

~~3.2.10 When a helicopter clearway is provided, it shall be located beyond the end of the rejected take-off area available FATO/TLOF.~~

b) —

3.2.11 **Recommendation.**— *The width of a helicopter clearway should not be less than that of the associated safety area (see Figure 3-7).*

e) —

~~3.2.12 **Recommendation.** — When solid, the surface of the helicopter clearway should not project above a plane having an upward slope of 3 per cent, the lower limit of this plane being a horizontal line which is located on the periphery of the FATO/TLOF.~~

*Editorial Note.* — Move Table 3-1 after 3.1.64.

**Table 3-1. FATO minimum separation distance**

If aeroplane mass and/or helicopter mass are	Distance between FATO edge and runway edge or taxiway edge
up to but not including 3 175 kg	60 m
3 175 kg up to but not including 5 760 kg	120 m
5 760 kg up to but not including 100 000 kg	180 m
100 000 kg and over	250 m

~~3.2.13 **Recommendation.** — An object situated on in a helicopter clearway which may endanger helicopters in the air should be regarded as an obstacle and should be removed.~~

### ***Touchdown and lift-off areas***

~~3.2.14 One TLOF shall be coincidental with the FATO.~~

~~*Note.* — Additional TLOFs may be collocated with helicopter stands.~~

~~3.2.15 For a TLOF coincidental with the FATO, the dimensions and the characteristics of the TLOF shall be the same as those of the FATO.~~

~~3.2.16 When the TLOF is collocated with a helicopter stand, the TLOF shall be of sufficient size to contain a circle of diameter of at least 0.83 D of the largest helicopter the area is intended to serve.~~

~~3.2.17 Slopes on a TLOF collocated with a helicopter stand shall be sufficient to prevent accumulation of water on the surface of the area, but shall not exceed 2 per cent in any direction.~~

~~3.2.18 When the TLOF is collocated with a helicopter stand and intended to be used by ground taxiing helicopters only, the TLOF shall at least be static load bearing and be capable of withstanding the traffic of the helicopters the area is intended to serve.~~

~~3.2.19~~ When the TLOF is collocated with a helicopter stand and intended to be used by air taxiing helicopters, the TLOF shall have a dynamic load bearing area.

### Safety areas

3.2.20~~12~~ The FATO/TLOF shall be surrounded by a safety area which need not be solid.

3.2.21~~13~~ A safety area surrounding a FATO/TLOF ~~intended to be used by helicopters operated in performance class 1 in visual meteorological conditions (VMC)~~ shall extend outwards from the periphery of the FATO/TLOF for a distance of at least 3 m or 0.25 D, whichever is greater, of the largest helicopter the FATO/TLOF is intended to serve and:

- a) each external side of the safety area shall be at least 2 D where the FATO/TLOF is quadrilateral; or
- b) the outer diameter of the safety area shall be at least 2 D where the FATO/TLOF is circular.

(See Figure 3-7.)

~~3.2.22~~ A safety area surrounding a FATO intended to be used by helicopters operated in performance class 2 or 3 in visual meteorological conditions (VMC) shall extend outwards from the periphery of the FATO for a distance of at least 3 m or 0.5 D, whichever is the greater, of the largest helicopter the FATO is intended to serve and:

- ~~a) each external side of the safety area shall be at least 2 D where the FATO is quadrilateral; or~~
- ~~b) the outer diameter of the safety area shall be at least 2 D where the FATO is circular.~~

3.2.23~~14~~ There shall be a protected side slope rising at 45 degrees from the edge of the safety area to a distance of 10 m, whose surface shall not be penetrated by obstacles, except that when obstacles are located to one side of the FATO/TLOF only, they may be permitted to penetrate the side slope surface.

*Note.— When only a single approach and take-off climb surface is provided, the need for specific protected side slopes would be addressed in the aeronautical study required in 4.2.10.*

3.2.24~~15~~ No fixed raised object shall be permitted on a safety area, except for frangible objects, which, because of their function, must be located on the area. No mobile object shall be permitted on a safety area during helicopter operations.

~~3.2.25~~ Objects whose function require them to be located on the safety area shall not exceed a height of 25 cm when located along the edge of the FATO nor penetrate a plane originating at a height of 25 cm above the edge of the FATO and sloping upwards and outwards from the edge of the FATO at a gradient of 5 per cent.

3.2.16 Objects whose function requires them to be located on the safety area shall not:

- a) if located at a distance of less than 0.75 D from the centre of the FATO/TLOF, penetrate a plane

at a height of 5 cm above the plane of the FATO/TLOF; and

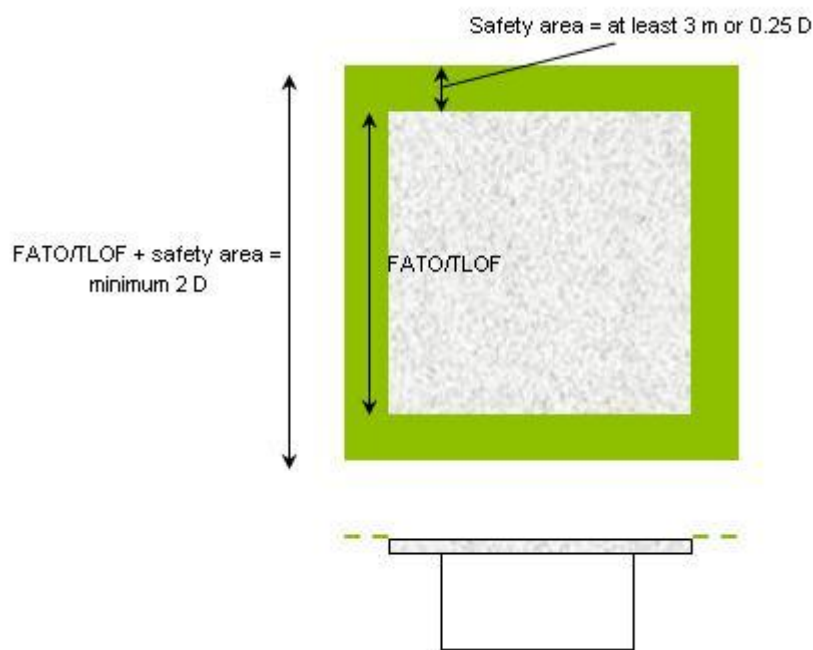
- b) if located at a distance of  $0.75 D$  or more from the centre of the FATO/TLOF, penetrate a plane originating at a height of 25 cm above the plane of the FATO/TLOF and sloping upwards and outwards at a gradient of 5 per cent.

3.2.26 **Recommendation.**— *In the case of a FATO of diameter less than  $1 D$ , the maximum height of the objects whose functions require them to be located on the safety area should not exceed a height of 5 cm.*

---

*Editorial Note.*— Insert new Figure 3-7 as follows:

---



**Figure 3-7. FATO/TLOF and associated safety area**

3.2.2717 The surface of the safety area, when solid, shall not exceed an upward slope of 4 per cent outwards from the edge of the FATO/TLOF.

3.2.2818 Where applicable, the surface of the safety area shall be prepared in a manner to prevent flying debris caused by rotor downwash.

3.2.2919 When solid, the surface of the safety area abutting the FATO/TLOF shall be continuous with the FATO/TLOF.

### ***Helicopter ground taxiways and ground taxi-routes***

*Note.— The following specifications are intended for the safety of simultaneous operations during the manoeuvring of helicopters. However, the wind velocity induced by the rotor downwash might have to be considered.*

3.2.3020 The width of a helicopter ground taxiway shall not be less than 2 times the largest width of the undercarriage (UCW) of the helicopters the ground taxiway is intended to serve (see Figure 3-8).

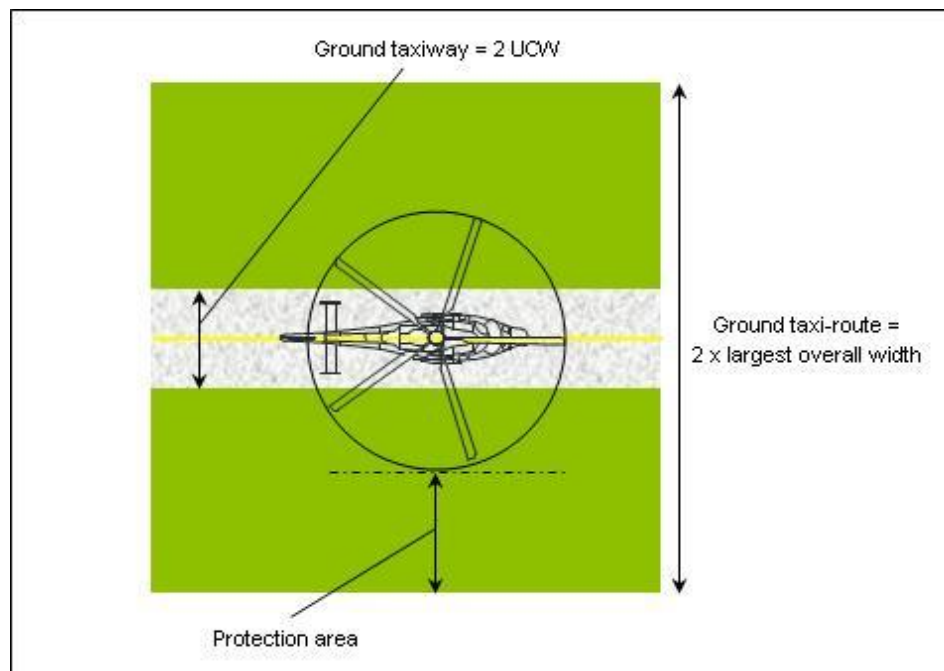
3.2.3121 The longitudinal slope of a helicopter ground taxiway shall not exceed 3 per cent.

3.2.3222 A helicopter ground taxiway shall be static load-bearing and be capable of withstanding the traffic of the helicopters the helicopter ground taxiway is intended to serve.

---

*Editorial Note.—* Insert new Figure 3-8 as follows:

---



**Figure 3-8. Helicopter ground taxi-route/taxiway**

3.2.33<sup>23</sup> A helicopter ground taxiway shall be centred on a ground taxi-route.

3.2.34<sup>24</sup> A helicopter ground taxi-route shall extend symmetrically on each side of the centre line to a distance not less than the largest overall width of the helicopters it is intended to serve.

3.2.35<sup>25</sup> No fixed raised objects shall be permitted on a helicopter ground taxi-route, except for frangible objects, which, because of their function, must be located thereon. No mobile object shall be permitted on a ground taxi-route during helicopter movements.

3.2.26 Objects whose function requires them to be located on a helicopter ground taxi-route shall not:

- a) be located at a distance of less than 50 cm from the edge of the helicopter ground taxiway; and
- b) penetrate a plane originating at a height of 25 cm above the plane of the taxiway, at a distance of 50 cm from the edge of the taxiway and sloping upwards and outwards at a gradient of 5 per cent.

3.2.36<sup>27</sup> The helicopter ground taxiway and the ground taxi-route shall provide rapid drainage but the helicopter ground taxiway transverse slope shall not exceed 2 per cent.

3.2.37<sup>28</sup> The surface of a helicopter ground taxi-route shall be resistant to the effect of rotor downwash.

3.2.29 For simultaneous operations, the helicopter ground taxi-routes shall not overlap.

***Helicopter air taxiways and air taxi-routes***

*Note.*— A helicopter air taxiway is intended to permit the movement of a helicopter above the surface at a height normally associated with ground effect and at ground speed less than 37 km/h (20 kt).

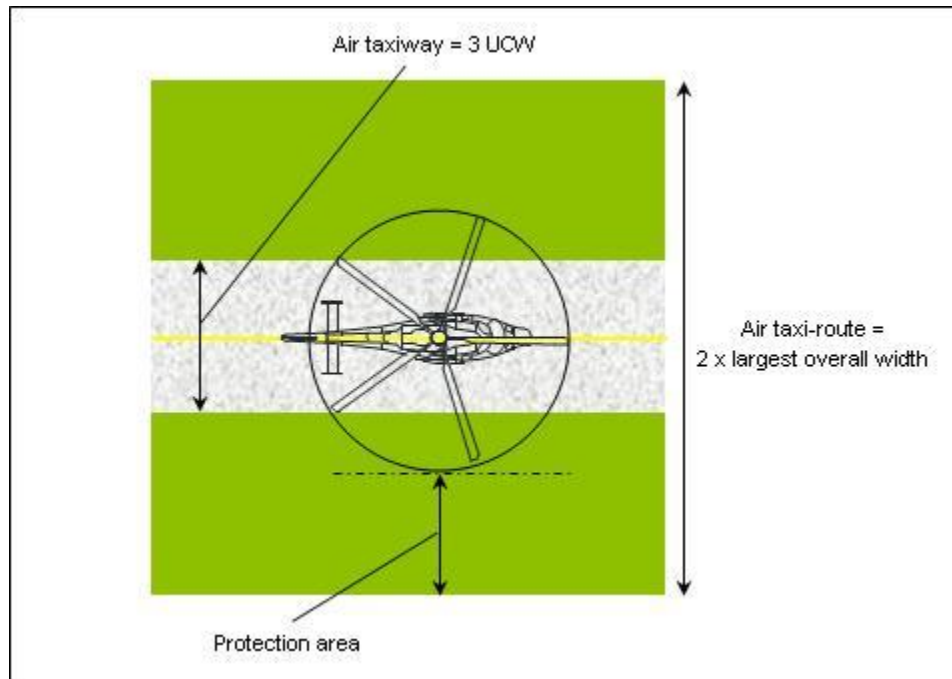
3.2.38<sup>30</sup> The width of a helicopter air taxiway shall be at least three times the largest width of the undercarriage (UCW) of the helicopters the air taxiway is intended to serve (see Figure 3-9).

3.2.39<sup>31</sup> The surface of a helicopter air taxiway shall be dynamic load-bearing.

---

*Editorial Note.*— Insert new Figure 3-9 as follows:

---



**Figure 3-9. Helicopter air taxi-route/taxiway**

3.2.4032 The transverse slopes of the surface of a helicopter air taxiway shall not exceed the slope landing limitations of the helicopters the air taxiway is intended to serve. In any event the transverse slope shall not exceed 2 per cent and the longitudinal slope shall not exceed 7 per cent. ~~In any event, the slopes shall not exceed the slope landing limitations of the helicopters the air taxiway is intended to serve.~~

3.2.4133 A helicopter air taxiway shall be centred on an air taxi-route.

3.2.4234 A helicopter air taxi-route shall extend symmetrically on each side of the centre line to a distance not less than the largest overall width of the helicopters it is intended to serve.

3.2.4335 No fixed raised objects shall be permitted on an air taxi-route, except for frangible objects, which, because of their function, must be located thereon. No mobile object shall be permitted on an air taxi-route during helicopter movements.

3.2.36 Objects whose function requires them to be located on an air taxi-route shall not:

- a) be located at a distance of less than 1 m from the edge of the air taxiway; and
- b) penetrate a plane originating at a height of 25 cm above the plane of the taxiway, at a distance of 1 m from the edge of the taxiway and sloping upwards and outwards at a gradient of 5 per cent.

3.2.37 **Recommendation.**— *Objects whose function requires them to be located on an air taxi-route should not:*

- a) *be located at a distance of less than 0.5 of the largest overall width of the helicopter for which designed from the centre line of the air taxiway; and*
- b) *penetrate a plane originating at a height of 25 cm above the plane of the taxiway, at a distance of 0.5 of the largest overall width of the helicopter for which designed from the centre line of the taxiway, and sloping upwards and outwards at a gradient of 5 per cent.*

3.2.44~~38~~ The surface of an air taxi-route shall be resistant to the effect of rotor downwash.

3.2.45~~39~~ The surface of an air taxi-route shall provide ground effect.

3.2.40 For simultaneous operations, the air taxi-routes shall not overlap.

### ***Aprons—Helicopter stands***

*Note.*— *The provisions of this section do not specify the location for helicopter stands but allow a high degree of flexibility in the overall design of the heliport. However, it is not considered good practice to locate helicopter stands under a flight path. See Heliport Manual (Doc 9261) for further guidance.*

3.2.46~~41~~ The helicopter stand shall provide rapid drainage but the slope in any direction on a helicopter stand shall not exceed 2 per cent.

*Note.*— *The requirements on the dimensions of helicopter stands assume the helicopter will turn in a hover when operating over a stand.*

3.2.47~~42~~ A helicopter stand intended to be used by helicopter turning in a hover shall be of sufficient size to contain a circle of diameter of at least 1.2 D of the largest helicopters the stand is intended to serve (see Figure 3-4).

3.2.48~~43~~ ~~If~~ ~~Where~~ a helicopter stand is intended to be used for taxi-through and where the helicopter using the stand is not required to turn, the minimum width of the stand and associated protection area shall be that of the taxi-route.

3.2.49~~44~~ ~~When~~ ~~Where~~ a helicopter stand is intended to be used for turning, the minimum dimension of the stand and protection area shall be not less than 2 D.

3.2.50~~45~~ ~~When~~ ~~Where~~ a helicopter stand is intended to be used for turning, it shall be surrounded by a protection area which extends for a distance of 0.4 D from the edge of the helicopter stand.

3.2.51~~46~~ For simultaneous operations, the protection areas of helicopter stands and their associated taxi-routes shall not overlap (see Figure 3-5).

*Note.*— *Where non-simultaneous operations are envisaged, the protection areas of helicopter stands and their associated taxi-routes may overlap (see Figure 3-6).*

~~3.2.52~~ When intended to be used for ground taxi operations by wheeled helicopters, the dimensions of a helicopter stand shall take into account the minimum turn radius of the wheeled helicopters the stand is intended to serve.

3.2.53~~47~~ A helicopter stand and associated protection area intended to be used for air taxiing shall provide ground effect.

3.2.54~~48~~ No fixed raised objects shall be permitted on a helicopter stand and the associated protection area.

3.2.49 No fixed raised object shall be permitted in the protection area around a helicopter stand except for frangible objects, which because of their function, must be located there.

3.2.50 No mobile object shall be permitted on a helicopter stand and the associated protection area during helicopter movements.

3.2.51 Objects whose function requires them to be located in the protection area shall not:

- a) if located at a distance of less than 0.75 D from the centre of the helicopter stand, penetrate a plane at a height of 5 cm above the plane of the central zone; and
- b) if located at distance of 0.75 D or more from the centre of the helicopter stand, penetrate a plane at a height of 25 cm above the plane of the central zone and sloping upwards and outwards at a gradient of 5 per cent.

3.2.55~~52~~ The central zone of the a helicopter stand shall be capable of withstanding the traffic of the helicopters it is intended to serve and have a load-bearing area:

- a) of diameter not less than 0.83 D of the largest helicopter it is intended to serve; or
- b) for a helicopter stand intended to be used for ground taxi-through, and where the helicopter using the stand is not required to turn, the same width as the ground-taxiway.

3.2.56~~53~~ The central zone of a helicopter stand intended to be used for ground taxiing only shall be static load-bearing.

3.2.57~~54~~ The central zone of a helicopter stand intended to be used for air taxiing shall be dynamic load-bearing.

*Note.— For a helicopter stand intended to be used for turning on the ground by wheeled helicopters, the dimension of the helicopter stand, including the dimension of the central zone, would need ~~might~~ have to be significantly increased. See Heliport Manual (Doc 9261) for further guidance.*

*Rationale*

On an elevated heliport it is assumed that the FATO and TLOF will always be coincidental. Editorial amendments are now made to cover this combined area referred to throughout a single section as “FATO/TLOF”.

A requirement to provide safety devices, such as safety nets or safety shelves, around the heliport perimeter for the protection of personnel is added as a standard. It is consistent with a similar requirement for safety devices already specified for helidecks and is intended to provide for the protection of personnel who might otherwise be at risk of falling straight into space.

A recommendation and a note are added to address the need to consider the influence of the surrounding environment, including turbulence. Lack of any specific location considerations in the past has sometimes led to heliport operations being restricted or limited, perhaps for the entire operating life of the facility, due to the adverse influence of the surrounding environment.

It is recognised that a helicopter clearway at ground level would not be appropriate at an elevated heliport for the case where helicopters are operating in performance class 1; indeed such operations set that the helicopter may fly (one engine inoperative) below the level of the heliport. In consideration of this the entire section relating to helicopter clearways is removed.

The standard relating to the height of objects permitted on the safety area is made more demanding to better ensure the safety of helicopter operations over the FATO. It is intended to better protect helicopters from the risk of inadvertent strikes with essential fixtures that may need to be so located close to the edge of the FATO, such as FATO perimeter lights; small helicopters can be specifically endangered by an obstacle strike.

The standards relating to objects on helicopter ground and air taxi-routes more precisely describe the objects permitted by taking into account their distance to the associated taxiway (edge or centre). They are intended to better protect helicopters from the risk of inadvertent strikes with essential fixtures that may need to be so located close to the edges of the taxiway, such as taxiway edge lights; small helicopters can be specifically endangered by an obstacle strike.

The standards relating to objects on helicopter stands more precisely describe the objects permitted on stands by taking into account their distance to the centre of the stand. It is consistent with a similar requirement for the height of objects permitted on the safety area and is intended to allow essential fixtures that may need to be so located on the protection area, with a combination of height and proximity to the stand that ensure the safety of helicopters.

### 3.3 Helidecks

*Note.— The following specifications are for helidecks located on structures engaged in such activities as mineral exploitation, research or construction. See 3.4 for shipboard heliport provisions.*

#### **Final approach and take-off area and touchdown and lift-off area**

*Note.— On helidecks it is presumed that the FATO and the TLOF will occupy the same space and have the same load bearing characteristics ~~be coincidental~~. Therefore any application Reference to FATO within the helideck section of this Annex is assumed automatically to include the TLOF so the combined term FATO/TLOF is used. Guidance on the effects of airflow direction and turbulence, prevailing wind velocity and high temperatures from gas turbine exhausts or flare-radiated heat on the location of the FATO/TLOF is given in the Heliport Manual (Doc 9261).*

3.3.1 The specifications in paragraphs 3.3.9~~13~~ and 3.3.10~~14~~ shall be applicable for helidecks completed on or after 1 January 2012.

3.3.2 A helideck shall be provided with ~~at least~~ one FATO/TLOF.

3.3.3 A FATO/TLOF may be any shape but shall be of sufficient size to contain:

a) for helicopters with a MTOM of more than 3175 kg, an area within which can be accommodated a circle of diameter of not less than 1.0 D of the largest helicopter the helideck is intended to serve; and

b) for helicopters with a MTOM of 3175 kg or less, an area within which can be accommodated a circle of diameter of not less than 0.83 D of the largest helicopter the helideck is intended to serve.

3.3.4 **Recommendation.** *For helicopters with a MTOM of 3175 kg or less, the FATO/TLOF should be of sufficient size to contain an area within which can be accommodated a circle of diameter of not less than 1.0 D of the largest helicopter the helideck is intended to serve.*

3.3.5 A helideck shall be arranged to ensure that a sufficient and unobstructed air-gap is provided which encompasses the full dimensions of the FATO/TLOF.

*Note.- Specific guidance on the characteristics of an air-gap is given in the Heliport Manual (Doc 9261). As a general rule, except for shallow superstructures of three stories or less, a sufficient air-gap will be at-least 3m.*

3.3.6 **Recommendation.** *The FATO/TLOF should be located so as to avoid, as far as is practicable, the influence of environmental effects, including turbulence, over the FATO/TLOF, which could have an adverse impact on helicopter operations.*

3.3.5~~7~~ A FATO/TLOF shall be dynamic load-bearing.

3.3.6~~8~~ A FATO/TLOF shall provide ground effect.

3.3.79 No fixed object shall be permitted around the edge of the FATO/TLOF except for frangible objects, which, because of their function, must be located thereon.

3.3.810 For any FATO/TLOF having a D-value of greater than 16.0m, ~~○~~ objects in the obstacle free sector whose function requires them to be located on the edge of the FATO/TLOF shall not exceed a height of 25 cm., ~~except that in the case of a FATO of diameter less than 1D the maximum height of such objects shall not exceed a height of 5 cm.~~

3.3.11 For any FATO/TLOF having a D-value of 16.0m or less, objects in the obstacle free sector whose function requires them to be located on the edge of the FATO/TLOF, shall not exceed a height of 5 cm.

3.3.12 For any FATO/TLOF having dimensions of less than 1D, the maximum height of such objects in the obstacle free sector whose function requires them to be located on the edge of the FATO/TLOF shall not exceed a height of 5 cm.

*Note.- Lighting that is mounted at a height of less than 25 cm is typically assessed for adequacy of visual cues before and after installation.*

3.3.913 Objects whose function requires them to be located within the FATO/TLOF (such as lighting or nets) shall not exceed a height of 2.5 cm. Such objects ~~may~~ shall only be present ~~only~~ if they do not represent a hazard to helicopters.

*Note.- Examples of potential hazards include nets or raised fittings on the deck that might induce dynamic rollover for helicopters equipped with skids.*

3.3.4014 Safety devices such as safety nets or safety shelves shall be located around the edge of a helideck but shall not exceed the helideck height of the FATO/TLOF.

3.3.415 The surface of the FATO/TLOF shall be skid-resistant to both helicopters and persons and be sloped to prevent pooling of water.

*Note.- Guidance on rendering the surface of the FATO/TLOF skid-resistant is contained in the Heliport Manual (Doc 9261).*

#### *Rationale*

On a helideck it is assumed that the FATO and TLOF will always be coincidental. Editorial amendments are now made to cover this combined area referred to throughout the section as “FATO/TLOF”.

A Standard, a Recommendation and a Note are added to address the need to consider the influence of the surrounding environment, including turbulence effects. To promote

beneficial wind flow over the helideck an unobstructed air-gap is specified. The location of the helideck relative to all aspects of the topside arrangement should take account of the need to minimise any effects of the surrounding environment on helicopter operations. Lack of any specific design considerations in the past has led to poorly designed and/or located topside arrangements, which have often led to helideck operations being restricted or limited, perhaps for the entire operating life of a fixed or floating facility, due to the adverse influence of the surrounding environment.

The standards relating to the height of objects permitted around the edge of the FATO/TLOF, in the obstacle free sector, are extended for smaller helicopter types to better ensure the safety of helicopter operations at the helideck - new standards now capture all FATO/TLOFs where the D value is 16.0m or less regardless of whether this equates to 1D, or is less than 1D, for the design helicopter. The new more demanding standards relating to objects around the edge of the FATO/TLOF, in the obstacle free sector, are intended to protect a larger range of smaller (mainly skid fitted) helicopter types from the risk of inadvertent strikes with essential fixtures that may need to be so located around the FATO/TLOF. A trawl of incidents and accidents around the world has indicated a number of obstacle strikes due to the combination of height and the proximity of essential objects to the touchdown location.

### 3.4 Shipboard heliports

3.4.1 The specifications in paragraph 3.4.11 and 3.4.16 shall be applicable to shipboard heliports completed on or after 1 January 2012 and 1 January 2015 respectively.

3.4.2 When helicopter operating areas are provided in the bow or stern of a ship or are purpose-built above the ship's structure, they shall be regarded as purpose-built shipboard heliports.

#### ***Final approach and take-off area and touchdown and lift-off area***

*Note.— On shipboard heliports it is presumed that the FATO and the TLOF will occupy the same space and have the same load bearing characteristics be coincidental. Therefore any application Reference to FATO within the shipboard heliport section of this Annex is assumed automatically to include the TLOF so the combined term FATO/TLOF is used. Guidance on the effects of airflow direction and turbulence, prevailing wind velocity and high temperature from gas turbine exhausts or flare-radiated heat on the location of the FATO/TLOF is given in the Heliport Manual (Doc 9261).*

3.4.3 A Shipboard heliports shall be provided with at least one FATO/TLOF.

3.4.4 The FATO/TLOF of a shipboard heliport shall be dynamic load-bearing.

3.4.5 The FATO/TLOF of a shipboard heliport shall provide ground effect.

3.4.6 For purpose-built shipboard heliports provided in a location other than the bow or stern, the FATO/TLOF shall be of sufficient size to contain a circle with a diameter not less than 1.0 D of the largest helicopter the heliport is intended to serve.

3.4.7 For purpose-built shipboard heliports provided in the bow or stern of a ship, the FATO/TLOF shall be of sufficient size to:

a) contain a circle with a diameter not less than 1 D of the largest helicopter the heliport is intended to serve; or

b) for operations with limited touchdown directions, contain an area within which can be accommodated two opposing arcs of a circle with a diameter of not less than 1D in the helicopter's longitudinal direction. The minimum width of the heliport shall be not less than 0.83D (See Figure 3.810).

*Note 1 — The ship will need to be manoeuvred to ensure that the relative wind is appropriate to the direction of the helicopter touchdown heading.*

*Note 2 — The touchdown heading of the helicopter is limited to the angular distance subtended by the 1 D arcs headings, minus the angular distance which corresponds to 15 degrees at each end of the arc.*

3.4.8 For non-purpose built shipboard heliports, the FATO/TLOF shall be of sufficient size to contain a circle with a diameter not less than 1D of the largest helicopter the helideck is intended to serve.

3.4.9 A shipboard heliport shall be arranged to ensure that a sufficient and unobstructed air-gap is provided which encompasses the full dimensions of the FATO/TLOF.

*Note.- Specific guidance on the characteristics of an air-gap is given in the Heliport Manual (doc 9261). As a general rule, except for shallow superstructures of three stories or less, a sufficient air-gap will be at-least 3m.*

3.4.10 **Recommendation.** *The FATO/TLOF should be located so as to avoid, as far as is practicable, the influence of environmental effects, including turbulence, over the FATO/TLOF, which could have an adverse impact on helicopter operations.*

3.4.911 No fixed object shall be permitted around the edge of the FATO/TLOF except for frangible objects, which, because of their function, must be located thereon.

3.4.1012 For any FATO/TLOF having a D-value of greater than 16.0m,  $\Theta$ -objects in the obstacle free sector whose function requires them to be located on the edge of the FATO/TLOF shall not exceed a height of 25 cm.

3.4.13 For any FATO/TLOF having a D-value of 16.0m or less, objects in the obstacle free sector, whose function requires them to be located on the edge of the FATO/TLOF, shall not exceed a height of 5 cm.

3.4.14 For any FATO/TLOF having dimensions of less than 1D, the maximum height of such objects in the obstacle free sector whose function requires them to be located on the edge of the FATO/TLOF shall not exceed a height of 5 cm.

*Note.— Lighting that is mounted at a height of less than 25 cm is typically assessed for adequacy of visual cues before and after installation.*

3.4.15 Objects whose function requires them to be located within the FATO/TLOF (such as lighting or nets) shall not exceed a height of 2.5 cm. Such objects may **shall only** be present ~~only~~ if they do not represent a hazard to helicopters.

3.4.16 Safety devices such as safety nets or safety shelves shall be located around the edge of a shipboard heliport, except where structural protection exists, but shall not exceed the height of the FATO/TLOF.

3.4.17 The surface of the FATO/TLOF shall be skid-resistant to both helicopters and persons.

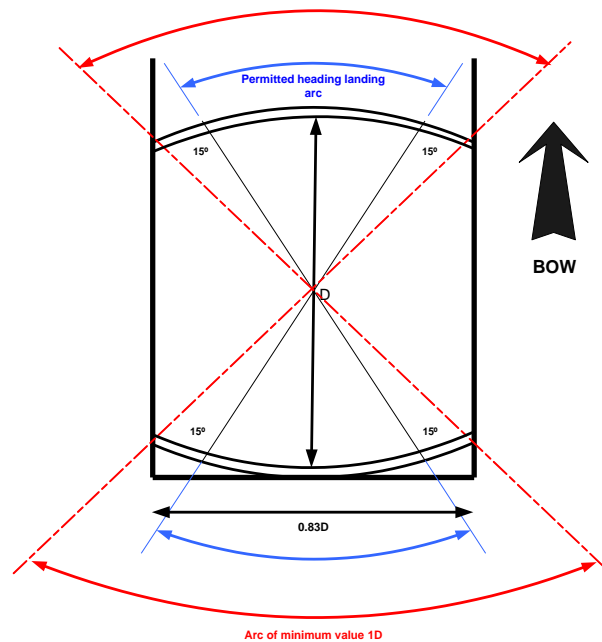


Figure 3-810. Shipboard permitted landing headings for limited heading operations

*Rationale*

On a shipboard heliport it is assumed that the FATO and TLOF will always be coincidental. Editorial amendments are now made to cover this combined area referred to throughout the section as “FATO/TLOF”.

A requirement to provide safety devices, such as safety nets or safety shelves, around the heliport perimeter, except where structural protection exists, is added as a standard; it is consistent with a similar requirement for safety devices already specified for helidecks and is intended to provide for the protection of personnel who might otherwise be at risk of slipping, tripping or a falling straight into the sea.

A Standard, a Recommendation and a Note are added to address the need to consider the influence of the surrounding environment, including turbulence effects. To promote beneficial wind flow over the shipboard heliport an unobstructed air-gap is specified. The location of the heliport relative to all aspects of a ship's topside arrangement should take account of the need to minimise any effects of the surrounding environment on helicopter operations. Lack of any specific design considerations in the past has led to poorly designed and/or poorly located shipboard heliports, which have often led to operations being restricted or limited, perhaps for the entire operating life of a ship, due to the adverse influence of the surrounding environment.

The standards relating to the height of objects permitted around the edge of the FATO/TLOF, in the obstacle free sector, are extended for smaller helicopter types to better ensure the safety of helicopter operations at a shipboard heliport - new standards now capture all FATO/TLOFs where the D value is 16.0m or less regardless of whether this equates to 1D, or is less than 1D, for the design helicopter. The new more demanding standards relating to objects around the edge of the FATO/TLOF, in the obstacle free sector, are intended to protect a larger range of smaller (mainly skid fitted) helicopter types from the risk of inadvertent strikes with essential fixtures that may need to be so located around the FATO/TLOF. A trawl of incidents and accidents around the world has indicated a number of obstacle strikes due to a combination of height and the proximity of essential objects to the touchdown location.

## CHAPTER 4. OBSTACLE ENVIRONMENT RESTRICTION AND REMOVAL

*Note.* — *The objectives of the specifications in this chapter are to ~~define~~ describe the airspace around heliports ~~to be maintained free from obstacles~~ so as to permit the intended helicopter operations ~~at the heliports~~ to be conducted safely and to prevent, where appropriate State controls exist, the heliports from becoming unusable by the growth of obstacles around them. This is achieved by establishing a series of obstacle limitation surfaces that define the limits to which objects may project into the airspace.*

### 4.1 Obstacle limitation surfaces and sectors

#### *Approach surface*

4.1.1 *Description.* An inclined plane or a combination of planes or, when a turn is involved, a complex surface sloping upwards from the end of the safety area and centred on a line passing through the centre of the FATO (see Figure 4-1) (or FATO/TLOF). There is an option for heliports intended to be used by helicopters operated in performance class 1 and when approved by an appropriate authority, to raise the origin of the inclined plane directly above the safety area.

*Note 1.- See Heliport Manual (Doc 9261) for guidance.*

*Note 2. — See Figure 4-1, 4-2, 4-3 and 4-4 for depiction of surfaces. See Table 4-1 for dimensions and slopes of surfaces.*

4.1.2 *Characteristics.* The limits of an approach surface shall comprise:

- a) an inner edge horizontal and equal in length to the minimum specified width of the FATO (or FATO/TLOF) plus the safety area, perpendicular to the centre line of the approach surface and located at the outer edge of the safety area;
- b) two side edges originating at the ends of the inner edge diverging uniformly at a specified rate from the vertical plane containing the centre line of the FATO (or FATO/TLOF); and
  - 1) ~~for other than a precision approach FATO, diverging uniformly at a specified rate from the vertical plane containing the centre line of the FATO~~
  - 2) ~~for a precision approach FATO, diverging uniformly at a specified rate from the vertical plane containing the centre line of the FATO, to a specified height above FATO, and then diverging uniformly at a specified rate to a specified final width and continuing thereafter at that width for the remaining length of the approach surface; and~~
- c) an outer edge horizontal and perpendicular to the centre line of the approach surface and at a specified height of 152 m (500 ft) above the elevation of the FATO (or FATO/TLOF) .

4.1.3 The elevation of the inner edge shall be the elevation of the safety area FATO (or FATO/TLOF) at the point on the inner edge that is intersected by the centre line of the approach surface.

4.1.4 The slope(s) of the approach surface shall be measured in the vertical plane containing the centre line of the surface.

4.1.5 In the case of an approach surface involving a turn, the surface shall be a complex surface containing the horizontal normal's to its centre line and the slope of the centre line shall be the same as that for a straight take-off climb surface.

*Note.* – See Figure 4-5

4.1.6 In the case of an approach surface involving a turn, the surface shall not contain more than one curved portion.

4.1.7 Where a curved portion of an approach surface is provided the sum of the radius of arc defining the centre line of the approach surface and the length of the straight portion originating at the inner edge shall not be less than 575 m.

4.1.8 Any variation in the direction of the centre line of an approach surface shall be designed so as not to necessitate a turn radius less than 270 m.

*Note.- For heliports intended to be used by helicopters operated in performance class 2 and 3, it is intended good practice for the that approach paths to be selected so as to permit safe forced landing or one-engine-inoperative landings such that, as a minimum requirement, injury to persons on the ground or water or damage to property are minimized. Provisions for forced landing areas are expected to minimize risk of injury to the occupants of the helicopter. The most critical helicopter type for which the heliport is intended and the ambient conditions will may be factors in determining the suitability of such areas.*

### Transitional surface

*Note.* – For a FATO (or FATO/TLOF) at a heliport without a PinS approach incorporating a visual segment surface (VSS) there is no requirement to provide transitional surfaces.

4.1.5 <sup>9</sup> *Description.* A complex surface along the side of the safety area and part of the side of the approach /take-off climb surface, that slopes upwards and outwards to the inner horizontal surface or a predetermined height of 45 m (150 ft).

*Note.* – See Figure 4-3 Transitional Surfaces. See Table 4-1 for dimensions and slopes of surfaces.

4.1.6 <sup>10</sup> *Characteristics.* The limits of a transitional surface shall comprise:

- a) a lower edge beginning at the intersection of the side of the approach /take-off climb surface with the inner horizontal surface, or beginning at a specified height above the lower edge when an inner horizontal surface is not provided, and extending down the side of the approach /take-off climb surface to the inner edge of the approach /take-off climb surface and from there along the length of the side of the safety area parallel to the centre line of the FATO (or FATO/TLOF); and
- b) an upper edge located in the plane of the inner horizontal surface, or at a specified height above the lower edge when an inner horizontal surface is not provided as set out in Table 4-1.

4.1.7 <sup>11</sup> The elevation of a point on the lower edge shall be:

- a) along the side of the approach surface - equal to the elevation of the approach surface at that point; and
- b) along the safety area - equal to the elevation of the centre line of the FATO (or FATO/TLOF) opposite that point.

*Note.* - As a result of b) the transitional surface along the safety area will be curved if the profile of the FATO is curved, or a plane if the profile is a straight line. ~~The intersection of the transitional surface with the inner horizontal surface, or upper edge when an inner horizontal surface is not provided, will also be a curved or a straight line depending on the profile of the FATO.~~

4.1.8 **12** The slope of the transitional surface shall be measured in a vertical plane at right angles to the centre line of the FATO (or FATO/TLOF).

#### Inner horizontal surface

*Note.*— ~~The intent of the inner horizontal surface is to allow safe visual manoeuvring.~~

~~4.1.9—Description. A circular surface located in a horizontal plane above a FATO and its environs.~~

~~Note.~~— ~~See Figure 4-1~~

~~4.1.10—Characteristics. The radius of the inner horizontal surface shall be measured from the mid-point of the FATO.~~

~~4.1.11—The height of the inner horizontal surface shall be measured above an elevation datum established for such purpose.~~

~~Note.~~— ~~Guidance on determining the elevation datum is contained in the Heliport Manual.~~

#### Conical surface

~~4.1.12—Description. A surface sloping upwards and outwards from the periphery of the inner horizontal surface, or from the outer limit of the transitional surface if an inner horizontal surface is not provided.~~

~~Note.~~— ~~See Figure 4-1~~

~~4.1.13—Characteristics. The limits of the conical surface shall comprise:~~

- ~~a) a lower edge coincident with the periphery of the inner horizontal surface, or outer limit of the transitional surface if an inner horizontal surface is not provided; and~~
- ~~b) an upper edge located at a specified height above the inner horizontal surface, or above the elevation of the lowest end of the FATO if an inner horizontal surface is not provided.~~

~~4.1.14—The slope of the conical surface shall be measured above the horizontal.~~

#### Take-off climb surface

4.1.15 **13** *Description.* An inclined plane, a combination of planes or, when a turn is involved, a complex surface sloping upwards from the end of the safety area and centred on a line passing through the centre of the FATO (or FATO/TLOF) (see Figure 4-1). There is an option for heliports intended to be used by helicopters operated in performance class 1 and when approved by an appropriate authority, to raise the origin of the inclined plane directly above the safety area.

*Note 1. - See Heliport Manual (Doc 9261) for guidance.*

*Note 2. - See Figure 4-1, 4-2, 4-3 and 4-4 for depiction of surfaces. See Table 4-1 for dimensions and slopes of surfaces.*

4.1.16 **14** *Characteristics.* The limits of a take-off climb surface shall comprise:

- a) an inner edge horizontal and equal in length to the minimum specified width/diameter of the FATO (or FATO/TLOF) plus the safety area, perpendicular to the centre line of the take-off climb surface and located at the outer edge of the safety area or clearway;
- b) two side edges originating at the ends of the inner edge and diverging uniformly at a specified rate from the vertical plane containing the centre line of the FATO (or FATO/TLOF); and
- c) an outer edge horizontal and perpendicular to the centre line of the take-off climb surface and at a specified height of 152 m (500 ft) above the elevation of the FATO (or FATO/TLOF).

4.1.17 **15** The elevation of the inner edge shall be the elevation of the safety area FATO (or FATO/TLOF) at the point on the inner edge that is intersected by the centre line of the take-off climb surface, ~~except that when a clearway is provided, the elevation shall be equal to the highest point on the ground on the centre line of the clearway.~~

4.1.16 Where a clearway is provided the elevation of the inner edge of the take-off climb surface shall be located at the outer edge of the clearway at the highest point on the ground based on the centre line of the clearway.

4.1.18 **17** In the case of a straight take-off climb surface, the slope shall be measured in the vertical plane containing the centre line of the surface.

4.1.19 **18** In the case of a take-off climb surface involving a turn, the surface shall be a complex surface containing the horizontal normal's to its centre line and the slope of the centre line shall be the same as that for a straight take-off climb surface. ~~That portion of the surface between the inner edge and 30 m above the inner edge shall be straight.~~

*Note. - See Figure 4-5.*

4.1.19 In the case of a take-off climb surface involving a turn, the surface shall not contain more than one curved portion.

4.1.20 Where a curved portion of a take-off climb surface is provided the sum of the radius of arc defining the centre line of the take-off climb surface and the length of the straight portion originating at the inner edge shall not be less than 575 m.

4.1.20 21 Any variation in the direction of the centre line of a take-off climb surface shall be designed so as not to necessitate a turn of radius less than 270 m.

*Note 1.— Helicopter take-off performance is reduced in a curve and as such a straight portion along the take-off climb surface prior to the start of the curve allows for acceleration.*

*Note 2.— For heliports intended to be used by helicopters operated in performance class 2 and 3 helicopters, it is intended that it is good practice for the departure paths should to be selected so as to permit safe forced landings or one-engine-inoperative landings such that, as a minimum requirement, injury to persons on the ground or water or damage to property are minimized. Provisions for forced landing areas are expected to minimize risk of injury to the occupants of the helicopter. The most critical helicopter type for which the heliport is intended and the ambient conditions will may be factors in determining the suitability of such areas.*

#### *Rationale*

Obstacle Restriction and Removal has been changed to Obstacle Environment to better reflect what the chapter stands for. Most descriptions now reference the FATO for elevation. Wording of performance operations is now consistent with Annex 6, Part 3.

Approach surfaces incorporating turns have been added, as it is just the reverse of the take-off climb surface.

Inner horizontal and conical surfaces have been removed, as they were a carry-over from fixed-wing circling criteria and do not occur in the heliport environment.

#### ***Obstacle-free sector/surface — helidecks***

4.1.212 *Description.* A complex surface originating at and extending from, a reference point on the edge of the FATO/TLOF of a helideck. In the case of a FATO/TLOF of less than 1 D, the reference point shall be located not less than 0.5D from the centre of the FATO/TLOF.

4.1.223 *Characteristics.* An obstacle-free sector/surface shall subtend an arc of specified angle.

4.1.234 A helideck obstacle-free sector shall comprise of two components, one above and one below helideck level (see Figure 4-2):

*Note: See Figure 4-7.*

a) Above helideck level: The surface shall be a horizontal plane level with the elevation of the helideck surface that subtends an arc of at least 210 degrees with the apex located on the periphery of the D reference circle extending outwards to a distance that will allow for an unobstructed departure path appropriate to the helicopter the helideck is intended to serve.

b) Below helideck level: Within the (minimum) 210-degree arc, the surface shall additionally extend downward from the edge of the FATO/TLOF below the elevation of the helideck to water level for an arc of not less than 180 degrees that passes through the centre of the FATO/TLOF and outwards to a distance that will allow for safe clearance from the obstacles below the helideck in the event of an engine failure for the type of helicopter the helideck is intended to serve.

*Note. For both the above obstacle free sectors for helicopters operated in Performance class 1 or 2 the horizontal extent of these distances from the helideck will be compatible with the one-engine inoperative capability of the helicopter type to be used.*

### Limited obstacle surface — helidecks

*Note. Where obstacles are necessarily located on the structure, a helideck may have a limited obstacle sector.*

4.1.245 *Description.* A complex surface originating at the reference point for the obstacle-free sector and extending over the arc not covered by the obstacle-free sector within which the height of obstacles above the level of the FATO/TLOF will be prescribed.

4.1.256 *Characteristics.* A limited obstacle sector shall not subtend an arc greater than 150 degrees. Its dimensions and location shall be as indicated in Figure 4-38 for a 1D FATO/TLOF and Figure 4-9 for a 0.83D FATO/TLOF.

#### *Rationale*

On a helideck it is assumed that the FATO and TLOF will always be coincidental. Editorial amendments are now made to cover this combined area referred to throughout the section as “FATO/TLOF”.

A FATO/TLOF for a helicopter with a MTOM of 3175 kg or less may accommodate a circle of diameter less than 1D, but not less than 0.83D (3.3.3b refers). Up until now there has not been a Figure presentation displaying sectors and surfaces for the 0.83D minimum size arrangement and it is considered that this information is very useful, if not essential, for designers of 0.83D helidecks. A scheme showing the sectors and surfaces for a 0.83D FATO/TLOF is presented as Figure 4-9.

## 4.2 Obstacle limitation requirements

*Note 1.- The requirements for obstacle limitation surfaces are specified on the basis of the intended use of a FATO (or FATO/TLOF), i.e. approach manoeuvre to hover or landing, or take-off manoeuvre and type of approach, and are intended to be applied when such use is made of the FATO (or FATO/TLOF). In cases where operations are conducted to or from both directions of a FATO (or FATO/TLOF), then the function of certain surfaces may be nullified because of more stringent requirements of another lower surface.*

*Note 2.— If a Visual approach slope indicator (VASI) is installed, there are additional obstacle protection surfaces, detailed in Chapter 5, that need to be considered and may be more demanding than the obstacle limitation surfaces prescribed in Table 4 -1.*

### **Surface level heliports**

4.2.1 The following obstacle limitation surfaces shall be established for a ~~precision approach FATO~~; a FATO (or FATO/TLOF) at heliports with a PinS approach procedure utilizing a visual segment surface:

- a) take-off climb surface;
- b) approach surface; and
- c) transitional surfaces;
- d) ~~Conical surface.~~

*Note 1.- See Figure 4-3 – Transitional Surfaces*

*Note 2.- Doc 8168, Volume II, Part IV – Helicopters, details further obstacle limitation surface requirements associated with a visual segment surface.*

4.2.2 ~~The following obstacle limitation surfaces shall be established for a non-precision approach FATO:~~

- a) ~~take-off climb surface;~~
- b) ~~approach surface;~~
- e) ~~transitional surfaces; and~~
- d) ~~conical surface if an inner horizontal surface is not provided.~~

4.2.3 ~~2~~ The following obstacle limitation surfaces shall be established for a ~~non-instrument~~ FATO (or FATO/TLOF) at heliports, other than specified in 4.2.1, including heliports with a PinS approach procedure where a visual segment surface is not provided:

- a) take-off climb surface; and
- b) approach surface.

4.2.4 ~~**Recommendation.** The following limitation surfaces should be established for a non-precision approach FATO~~

- a) ~~inner horizontal surface; and~~

*b) ~~conical surface.~~*

*Note. — An inner horizontal surface may not be required if a straight in non precision approach is provided at both ends.*

4.2.5 <sup>3</sup> The slopes of the obstacle limitation surfaces shall not be greater than, and their other dimensions not less than, those specified in Tables 4-1 to 4-4 and shall be located as shown in Figures 4-1, 4-2 and 4-6. 4-6-2 to and 4-10-5.

4.2.4 For heliports that utilize a 4.5% slope, objects shall be permitted to penetrate the obstacle limitation surface, if the results of an aeronautical study approved by an appropriate authority have reviewed the associated risks and mitigation measures. The identified objects may limit the heliport operation.

*Note. — Annex 6, Part 3 provides procedures that may be useful in determining the extent of obstacle penetration.*

4.2.6 <sup>5</sup> New objects or extensions of existing objects shall not be permitted above any of the surfaces in 4.2.1 to 4.2.4-<sup>2</sup> above except when, in the opinion of the appropriate authority, the new object or extension would be shielded by an existing immovable object. shielded by an existing immovable object or after an aeronautical study approved by an appropriate authority, determines that the object will not adversely affect the safety or significantly affect the regularity of operations of helicopters.

*Note. - Circumstances in which the shielding principle may reasonably be applied are described in the Airport Services Manual, Part 6.*

4.2.7 <sup>6</sup> **Recommendation.** - Existing objects above any of the surfaces in 4.2.1 to 4.2.4<sup>2</sup> should, as far as practicable, be removed except when, in the opinion the appropriate authority the object is shielded by an existing immovable object or after an aeronautical study approved by an appropriate authority ~~it is determined~~ determines that the object ~~would~~ will not adversely affect the safety or significantly affect the regularity of operations of helicopters.

*Note.- The application of curved approach or take-off climb surfaces as specified in 4.1.19 <sup>5</sup> or 4.1.18 may alleviate the problems created by objects infringing these surfaces.*

4.2.8 <sup>7</sup> A surface level heliport shall have at least two one take-off climb approach and approach take-off climb surface, s separated by not less than 150°. An aeronautical study shall be undertaken by an appropriate authority when only a single approach and take-off climb surface is provided considering as a minimum, the following factors:

- a) the area/terrain over which the flight is being conducted;
- b) the obstacle environment surrounding the heliport;
- c) the performance and operating limitations of helicopters intending to use the heliport; and
- d) the local meteorological conditions including the prevailing winds.

**4.2.8 Recommendation.** - *A surface level heliport should have at least two approach and take-off climb surfaces to avoid downwind conditions, minimize crosswind conditions and permit for a balked landing.*

*Note.* - See Heliport Manual (Doc 9261) for guidance.

~~4.2.9 **Recommendation.** *The number and orientation of take-off climb and approach surfaces should be such that the usability factor of a heliport is not less than 95 per cent for the helicopters the heliport is intended to serve.*~~

### ***Elevated heliports***

~~4.2.10~~ **9** The obstacle limitation requirements surfaces for elevated heliports shall conform to the requirements for surface level heliports specified in 4.2.1 to 4.2.7 ~~6~~.

~~4.2.11~~ **10** An elevated heliport shall have at least ~~one~~ **two** take-off climb approach and ~~approach~~ take-off climb surface.s separated by not less than 150°. An aeronautical study shall be undertaken by an appropriate authority when only a single approach and take-off climb surface is provided considering as a minimum, the following factors:

- a) the area/terrain over which the flight is being conducted;
- b) the obstacle environment surrounding the heliport;
- c) the performance and operating limitations of helicopters intending to use the heliport; and
- d) the local meteorological conditions including the prevailing winds.

**4.2.11 Recommendation.** - *An elevated heliport should have at least two approach and take-off climb surfaces to avoid downwind conditions, minimize crosswind conditions and permit for a balked landing.*

*Note.* - See Heliport Manual (Doc 9261) for guidance.

*Rationale*

Take-off climb / approach surface slopes have been simplified and have adopted angles that are consistent with world practices and actual helicopter departure or arrival profiles.

Surfaces associated with PinS approach utilizing a visual segment have been added to reflect similar surfaces detailed in PANS-OPS.

All diagrams have been updated to reflect changed (simplified) text.

*Helidecks*

*Note. The following specifications are for helidecks located on a structure and engaged in such activities as mineral exploitation, research, or construction, but excluding heliports on ships.*

4.2.12 A helideck shall have an obstacle-free sector.

*Note.- A helideck may have a limited obstacle sector (see 4.1.25).*

4.2.13 There shall be no fixed obstacles within the obstacle-free sector above the obstacle-free surface.

4.2.14 In the immediate vicinity of the helideck, obstacle protection for helicopters shall be provided below the helideck level. This protection shall extend over an arc of at least 180 degrees with the origin at the centre of the FATO/TLOF, with a descending gradient having a ratio of one unit horizontally to five units vertically from the edges of the FATO/TLOF within the 180-degree sector. This descending gradient may be reduced to a ratio of one unit horizontally to three within the 180° sector for multi-engine helicopters operated in performance class 1 or 2 (see Figure 4-27).

~~4.2.15 Where a mobile obstacle or combination of obstacles within the obstacle free sector is essential for the operation of the installation, the obstacle(s) shall not subtend an arc exceeding 30 degrees, as measured from the centre of the FATO.~~

*Note.- Where there is a requirement to position, at sea surface level, one or more offshore support vessel(s) (e.g. a Standby Vessel) essential to the operation of a fixed or floating offshore facility, but located within the proximity of the fixed or floating offshore facility, any offshore support vessel(s) would need to be positioned so as not to compromise the safety of helicopter operations during take-off departure and/or approach to landing.*

4.2.16 For a FATO/TLOF of 1D and larger, within the 150-degree limited obstacle surface/sector out to a distance of 0.62D, measured from the centre of the FATO, 0.12D measured from the point of origin of the limited obstacle sector, objects shall not exceed a height of 0.05D 25 cm above the FATO/TLOF. Beyond that arc, out to an over-all distance of 0.83D a further 0.21D measured from the end of the first sector, the limited obstacle surface rises at a rate of one unit vertically for each two units horizontally originating at a height 0.05D above the level of the FATO/TLOF (see Figure 4-38 which illustrates the surfaces/ sectors for a 1D FATO/TLOF).

---

*Editorial Note.*— Delete existing Figure 4-8.

---

*Note.- Where the area enclosed by the FATO/TLOF perimeter marking, is a shape other than circular, the extent of the LOS segments are represented as lines parallel to the perimeter of the landing area rather than arcs. Figure 4-8 has been constructed on the assumption that an octagonal helideck arrangement is provided. Further guidance for square (quadrilateral) and circular FATO/TLOF arrangements is given in the Heliport Manual.*

4.2.16 For a FATO/TLOF less than 1D, within the 150 degree limited obstacle surface/sector out to a distance of 0.62D and commencing from a distance 0.5D, both measured from the centre of the FATO/TLOF, objects shall not exceed a height of 5 cm above the FATO/TLOF.

Beyond that arc, out to an overall distance of 0.83D from the centre of the FATO/TLOF, the limited obstacle surface rises at a rate of one unit vertically for each two units horizontally originating at a height 0.05D above the level of the FATO/TLOF (see Figure 4-9 which illustrates the surfaces / sectors for a 0.83D FATO/TLOF).

*Note.- Where the area enclosed by the FATO/TLOF perimeter marking, is a shape other than circular, the extent of the LOS segments are represented as lines parallel to the perimeter of the FATO/TLOF rather than arcs. Figure 4-9 has been constructed on the assumption that an octagonal helideck arrangement is provided. Further guidance for square (quadrilateral) and circular FATO/TLOF arrangements is given in the Heliport Manual (Doc 9261).*

#### *Rationale*

In the current section of Volume II, 4.2.15 presents a ‘hard’ Standard for the control of mobile obstacles or combination of obstacles in the OFS, which effectively prohibits the siting of any essential obstacle on the sea surface within a prescribed ‘arc’. The Offshore Sub-group recognised that the Standard was too onerous and open to misinterpretation, being directed towards an installation that may have little control over mobile obstacles, in the proximity of a helideck, at sea surface level. Also the Standard makes no account for the flexibility of helicopters and the options that exist for avoiding over-flight of obstacles that may be located on the sea surface, such as ‘essential’ offshore support vessels. In consequence, the Standard is being downgraded to a more ‘realistic’ Note.

In the current section of Volume II obstacles located close to the edge of a helideck, in the first segment of the limited obstacle sector, are permitted to rise to a height of 0.05D above helideck level. For a typical 22m helicopter, this means allowable infringements in the 1<sup>st</sup> segment up to a ‘generous’ 1.1m ADL. According to the available global accident data, there have been a number of obstacle strikes, or near misses, involving a helicopter’s main rotor and obstacles legitimately located in the 1<sup>st</sup> segment of the LOS. To mitigate further obstacle strikes, an initiative is proposed which limits all obstacles in the 1<sup>st</sup> segment to 25 cm for helidecks of 1D and greater and to 5 cm for helidecks less than 1D. Accepting that the majority of new builds are either hexagonal or octagonal in shape, the two Figures reflecting the sectors and surfaces are based on a common octagonal arrangement with sectors (0.12D plus

0.21D) now measured from the origin of the OFS.
---

### *Shipboard heliports*

#### *Purpose-built heliports located forward or aft*

4.2.17 The specifications in paragraphs 4.2.20 and 4.2.22 shall be applicable for shipboard heliports completed on or after 1 January 2012.

#### *Purpose-built heliports located forward or aft*

4.2.18 When helicopter operating areas are provided in the bow or stern of a ship they shall apply the obstacle criteria given in 4.2.12, 4.2.14 and 4.2.16 above for helidecks.

#### *Amidships location – purpose built and non-purpose built*

4.2.19 Forward and aft of the minimum 1D FATO/TLOF shall be two symmetrically located sectors, each covering an arc of 150 degrees, with their apexes on the periphery of the FATO/TLOF ~~D-reference circle~~. Within the area enclosed by these two sectors, there shall be no objects rising above the level of the FATO/TLOF, except those aids essential for the safe operation of a helicopter and then only up to a maximum height of 25 cm.

4.2.20 Objects whose function requires them to be located within the FATO/TLOF (such as lighting or nets) shall not exceed a height of 2.5 cm. Such objects ~~may~~ shall only be present if they do not represent a hazard to helicopters.

*Note.- Examples of potential hazards include nets or raised fittings on the deck that might induce dynamic rollover for helicopters equipped with skids.*

4.2.21 To provide further protection from obstacles fore and aft of the FATO/TLOF, rising surfaces with gradients of one unit vertically to five units horizontally shall extend from the entire length of the edges of the two 150 degree sectors. These surfaces shall extend for a horizontal distance equal to at least 1 D of the largest helicopter the FATO/TLOF is intended to serve and shall not be penetrated by any obstacle (see Figure 4-910).

#### *Non-purpose built heliports*

##### *Ship's side location*

4.2.22 No objects shall be located within the FATO/TLOF except those aids essential for the safe operation of a helicopter (such as nets or lighting) and then only up to a maximum height of 2.5cm. Such objects shall only be present if they do not represent a hazard to helicopters.

4.2.23 From the fore and aft mid-points of the ~~D reference circle~~ in two segments outside the circle, ~~an~~ limited obstacle areas shall extend to the ship's rail to a fore and aft distance of 1.5 times the diameter of the FATO/TLOF, located symmetrically about the athwartships bisector of the ~~reference-D~~ circle. Within

~~this these areas sector there shall be no objects rising above a maximum height of 25cm above the level of the FATO/TLOF, except those aids essential to the safe operation of the helicopter and then only up to a maximum height of 25 cm (see Figure 4-101). Such objects shall only be present if they do not represent a hazard to helicopters.~~

4.2.24 A **limited obstacle sector** horizontal surface shall be provided, at least  $0.25 D$  **times** beyond the diameter of the **D reference** circle, which shall surround the inboard sides of the FATO/TLOF to the fore and aft mid-points of the D circle. The limited obstacle sector shall continue to the ship's rail to a fore and aft distance of 2.0 times the diameter of the FATO/TLOF, located symmetrically about the athwart ships bisector of the D circle. Within this sector there shall be no objects rising above a maximum height of 25cm above the level of the FATO/TLOF ~~and the obstacle free sector at a height of 0.05 times the diameter of the reference circle, which no object shall penetrate.~~

*Note. Any objects located within the areas described in 4.2.23 and 4.2.24 that exceed the height of the FATO/TLOF are notified to the helicopter operator using a ship's helicopter landing area plan. For notification purposes it may be necessary to consider immovable objects beyond the limit of the surface prescribed in 4.2.24 particularly if objects are significantly higher than 25 cm and in close proximity to the boundary of the Limited Obstacle Sector. See Heliport Manual (Doc 9261) for guidance.*

#### *Winching areas*

4.2.25 An area designated for winching on-board ships shall **be** comprised **of** a circular clear zone of diameter 5m and extending from the perimeter of the clear zone, a concentric manoeuvring zone of diameter  $2D$ . (See Figure 4-112)

4.2.26 The manoeuvring zone shall **be** comprised **of** 2 areas:

- a) The inner manoeuvring zone extending from the perimeter of the clear zone and of a circle of diameter not less than  $1.5D$ ; and
- b) The outer manoeuvring zone extending from the perimeter of the inner manoeuvring zone and of a circle of diameter of not less than  $2D$ .

4.2.27 Within the clear zone of a designated winching area, no objects shall be located above the level of its surface.

4.2.28 Objects located within the inner manoeuvring zone of a designated winching area shall not exceed a height of 3m.

4.2.29 Objects located within the outer manoeuvring zone of a designated winching area shall not exceed a height of 6m.

*Note. - See Heliport Manual (Doc 9261) for guidance.*

*Rationale*

On a shipboard heliport it is assumed that the FATO and TLOF will always be coincidental. Editorial amendments are now made to cover this combined area referred to throughout the section as “FATO/TLOF”.

For non purpose built heliports located on a ship’s side, the obstacle limitation surfaces are being extensively revised to ensure that the requirements are consistent with the corresponding (new) SARPS for helidecks (see rationale 14), maintaining appropriate levels of safety while reflecting the real life situation with a non-purpose built landing area, provided within the superstructure of a ship. A system for recording and mapping objects in the vicinity of the FATO/TLOF is introduced in a Note.

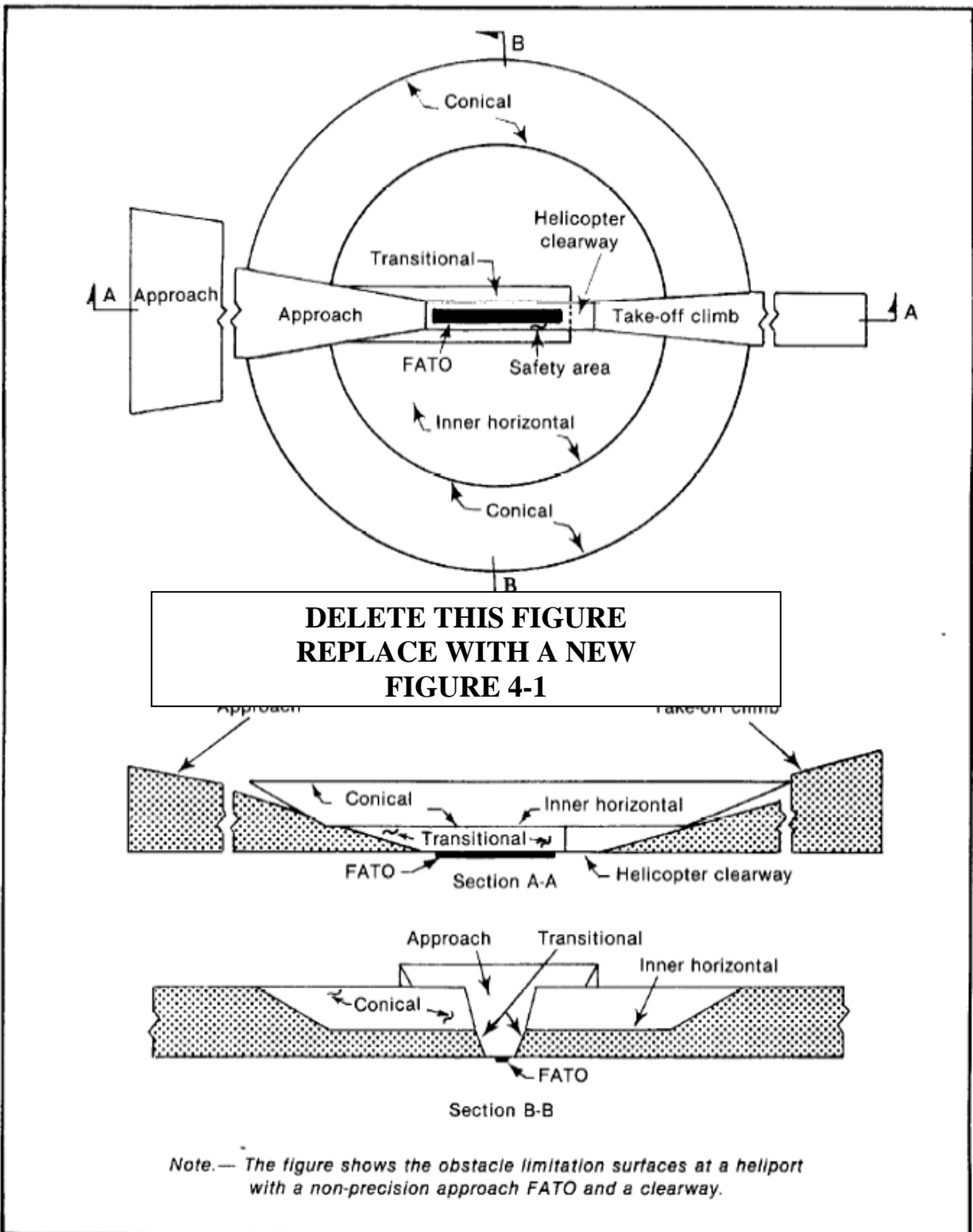


Figure 4-1. Obstacle limitation surfaces

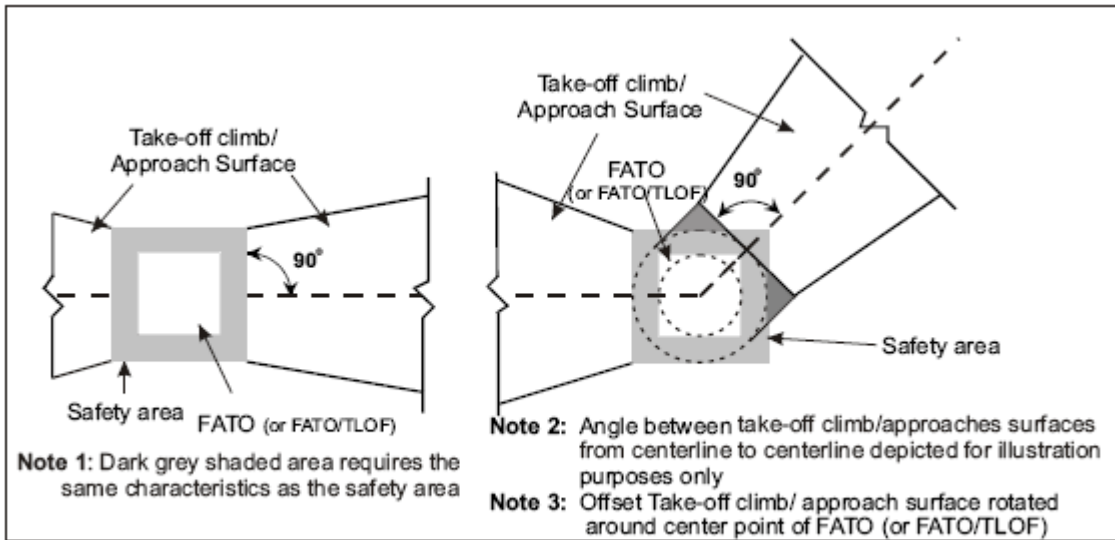


Figure 4-1. Obstacle Limitation Surfaces - Take-off Climb & Approach Surface

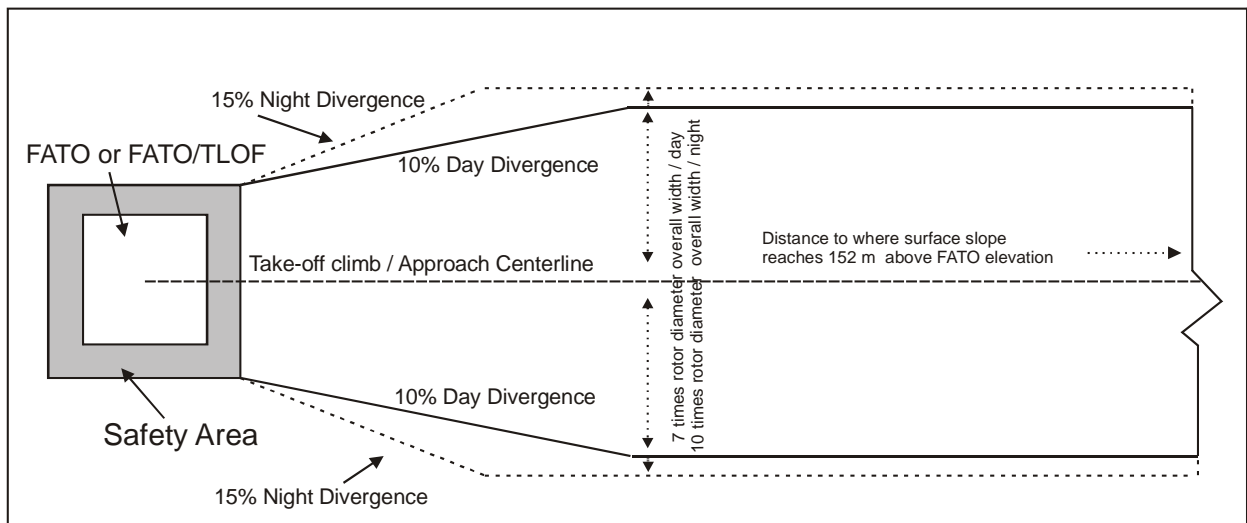
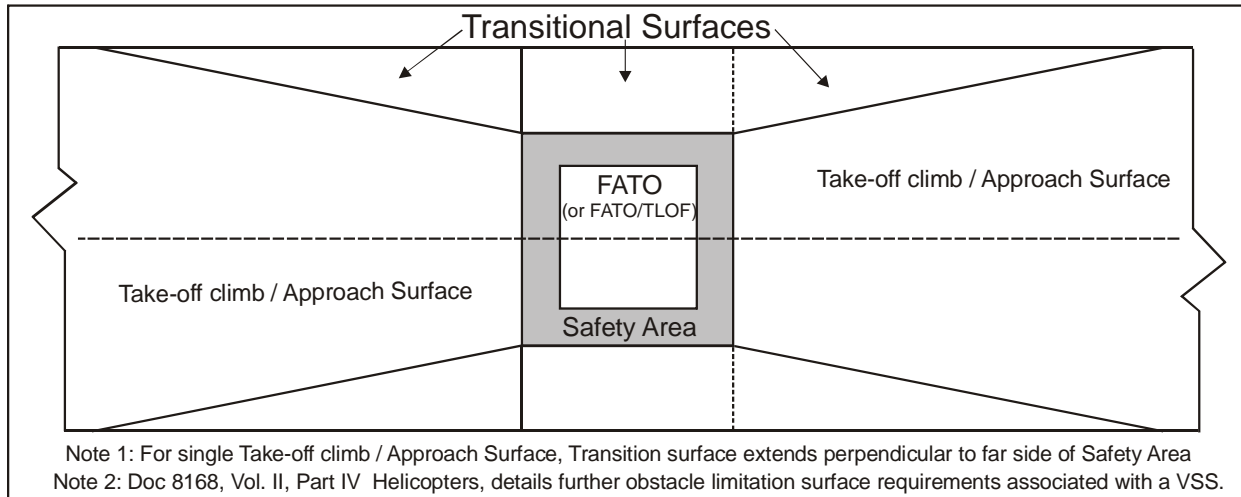
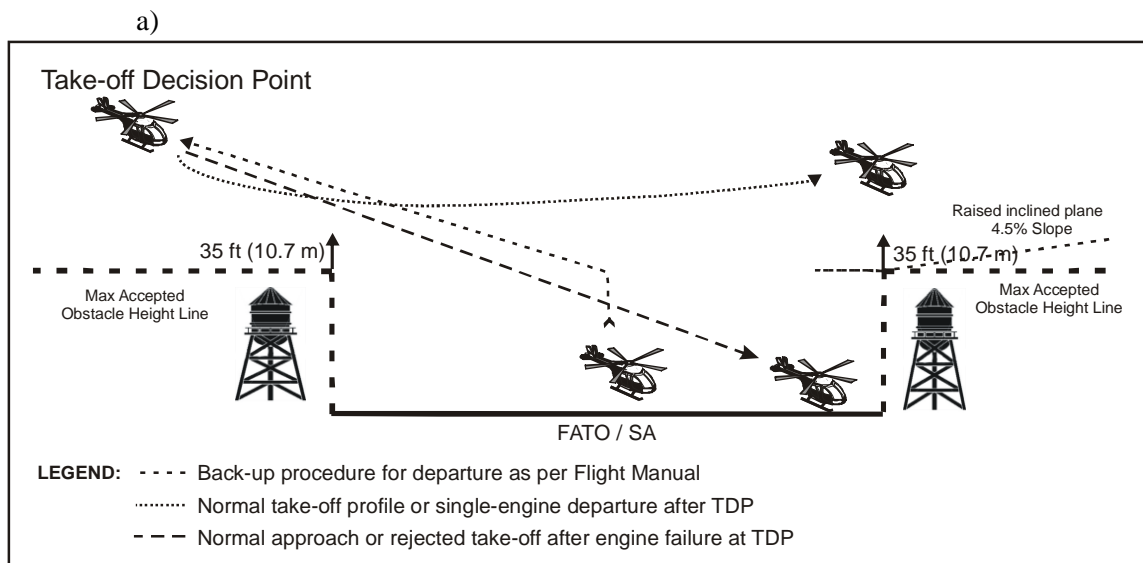


Figure 4-2 Take-off Climb / Approach Surface Width



**Figure 4-3 Transitional Surfaces for a FATO with a PinS approach procedure with a VSS**



**Figure 4-4 Example of Raised Inclined Plane During Operations in Performance Class 1**

*Note 1.- This example diagram does not represent any specific profile, technique or helicopter type and is intended to show a generic example. An approach profile and a back-up procedure for departure profile are depicted. Specific manufacturers operations in performance class 1 may be represented differently in the specific Helicopter Flight Manual. Annex 6, Part 3, Attachment A provides back-up procedures that may be useful for operations in performance class 1.*

*Note 2.- The approach / landing profile may not be the reverse of the take-off profile.*

Note 3.— Additional obstacle assessment might be required in the area that a back-up procedure is intended. Helicopter performance and the Helicopter Flight Manual limitations will determine the extent of the assessment required.

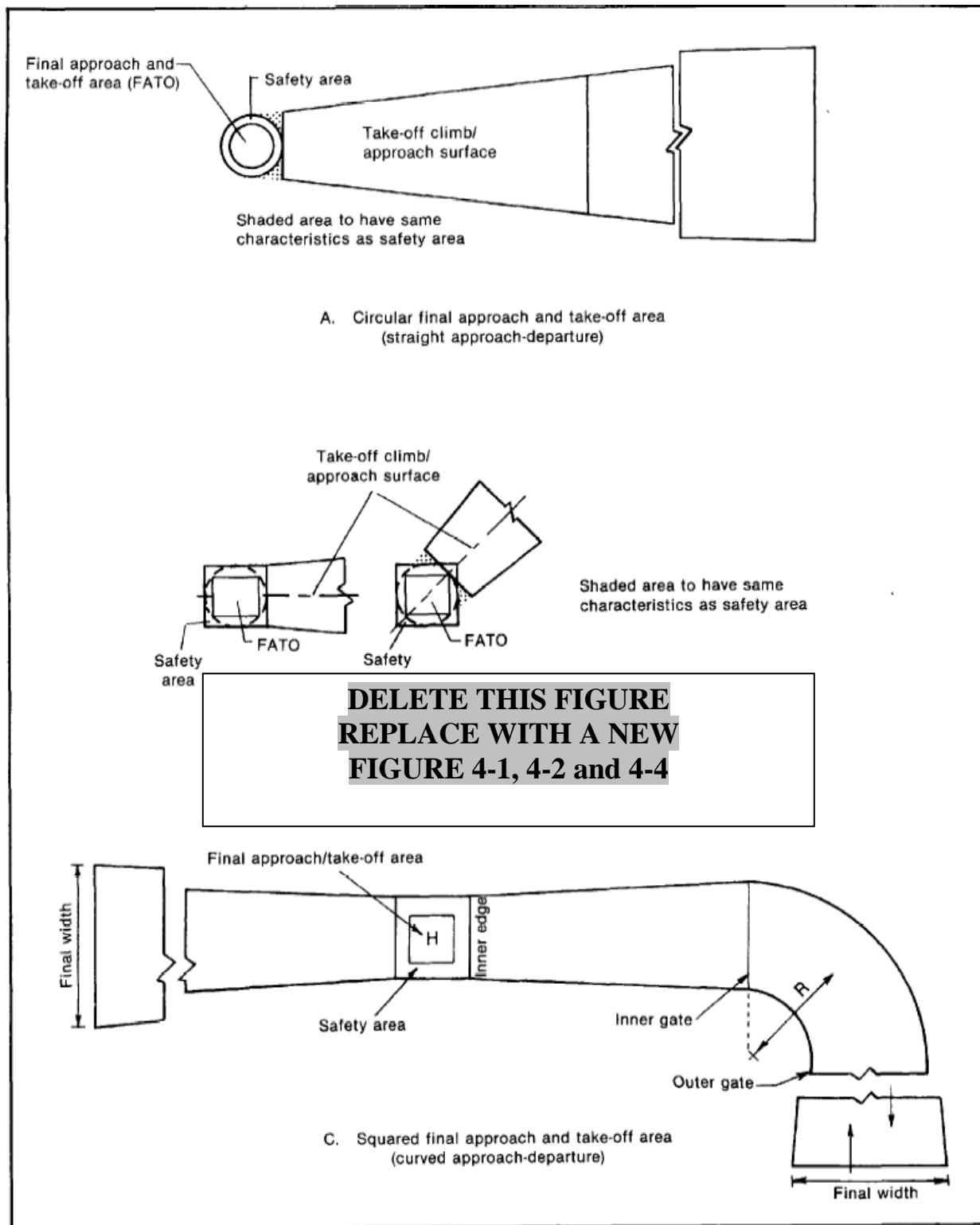


Figure 4-6. Take-off climb/approach surface (non-instrument FATO)

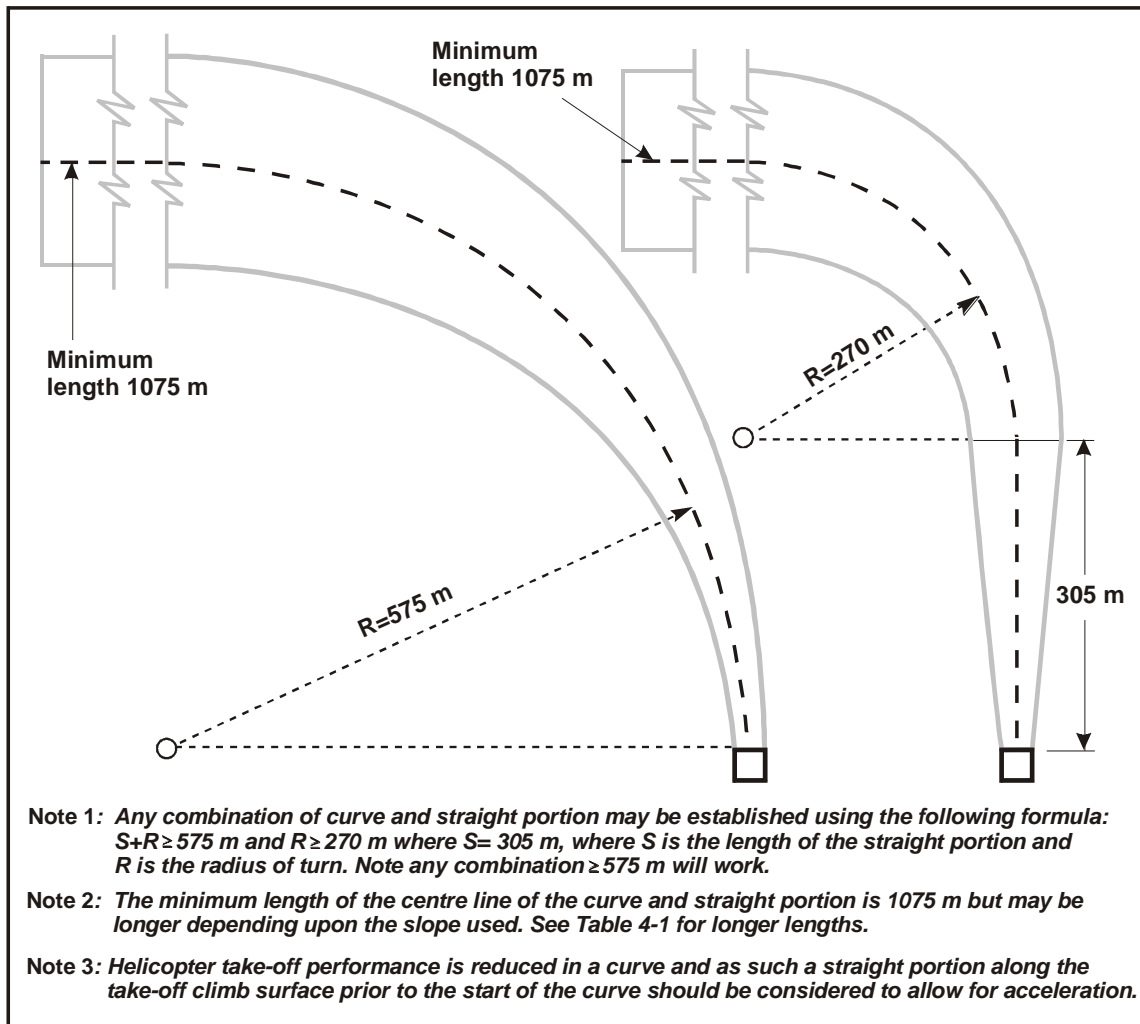


Figure 4-5. Curved approach and take-off climb surface for all FATOs including FATO/TLOFs

---

*Editorial Note.*— Existing Figure 4-5 relocated to Appendix 2, Figure A4-1.

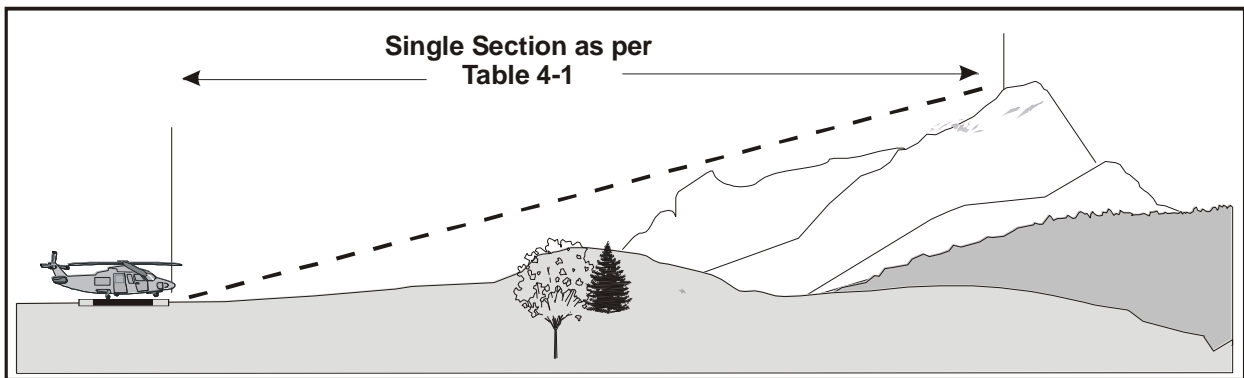
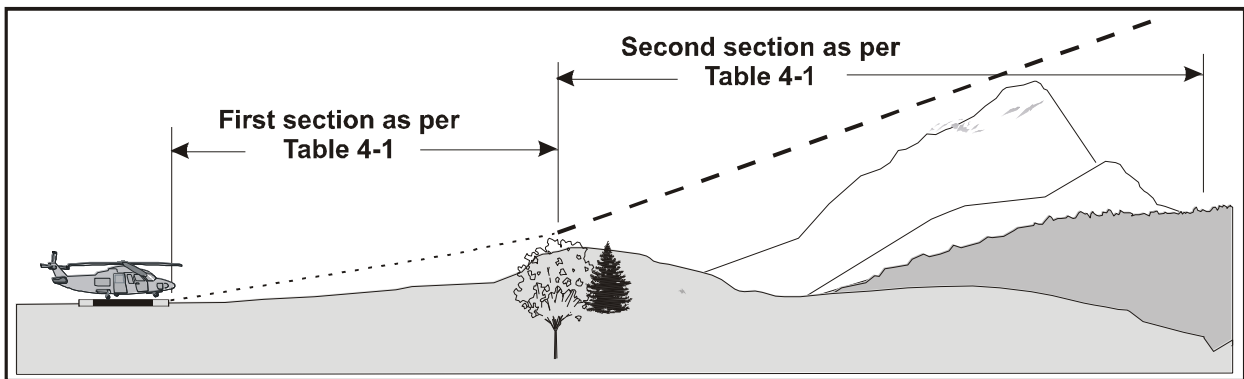
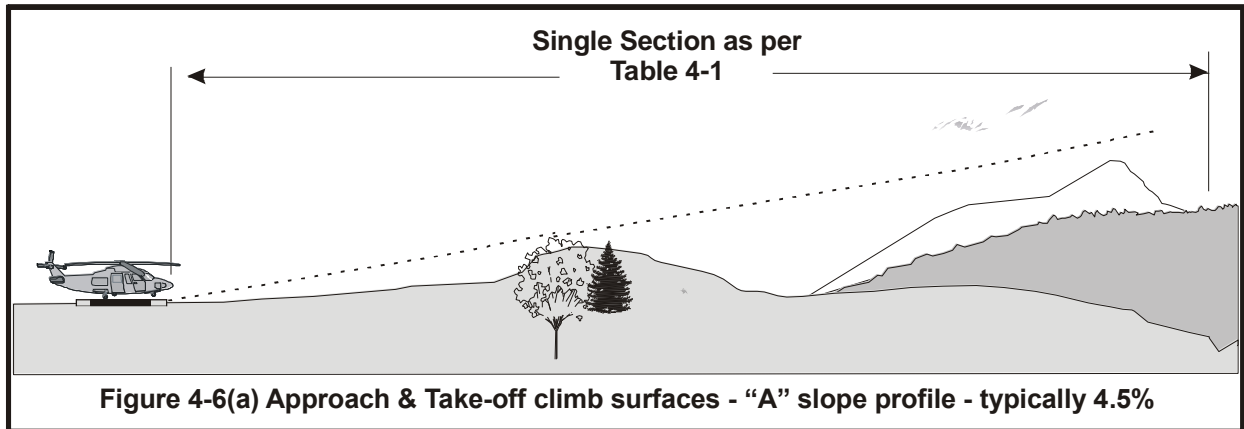
---

*Editorial Note.*— Existing Figure 4-6 relocated to Appendix 2, Figure A4-2.

---

*Editorial Note.*— Existing Figure 4-7 relocated to Appendix 2, Figure A4-3.

---



---

*Editorial Note.*— Relevant data from Tables 4-1, 4-3 and 4-4 combined into new Table 4-1.

---

---

*Editorial Note.*— Table 4-2 moved in its entirety to Table A4-2 in Appendix 2.

---

---

*Editorial Note.*— Relevant data from existing Table 4-1 also used to create new Table A4-1 in Appendix 2.

---

---

*Editorial Note.*— Relevant data from existing Table 4-3 also used to create new Table A4-3 in Appendix 2.

---

Table 4-1. Dimensions and slopes of obstacle limitation surfaces

## NON-INSTRUMENT AND NON-PRECISION FATO

Surface and dimensions		Non-instrument (visual) FATO			Non-precision (instrument approach) FATO
		Helicopter performance class			
		1	2	3	
<b>APPROACH SURFACE</b>					
Width of inner edge		Width of safety area			Width of safety area
Location of inner edge		Boundary			Boundary
<i>First section</i>					
Divergence	— day	10%	10%	10%	16%
	— night	15%	15%	15%	
Length	— day	245 m <sup>a</sup>	245 m <sup>a</sup>	245 m <sup>a</sup>	2 500 m
	— night	245 m <sup>a</sup>	245 m <sup>a</sup>	245 m <sup>a</sup>	
Outer width	— day	49 m <sup>b</sup>	49 m <sup>b</sup>	49 m <sup>b</sup>	890 m
	— night	73.5 m <sup>b</sup>	73.5 m <sup>b</sup>	73.5 m <sup>b</sup>	
Slope (maximum)		8% <sup>a</sup>	8% <sup>a</sup>	8% <sup>a</sup>	3.33%
<i>Second section</i>					
Divergence	— day	10%	10%	10%	—
	— night	15%	15%	15%	
Length	— day	c	c	c	—
	— night	c	c	c	
Outer width	— day	d	d	d	—
	— night	d	d	d	
Slope (maximum)		12.5%	12.5%	12.5%	—
<i>Third section</i>					
Divergence		parallel	parallel	parallel	—
Length	— day	e	e	e	—
	— night	e	e	e	
Outer width	— day	d	d	d	—
	— night	d	d	d	
Slope (maximum)		15%	15%	15%	—
<b>INNER HORIZONTAL</b>					
Height		—	—	—	45 m
Radius		—	—	—	2 000 m
<b>CONICAL</b>					
Slope		—	—	—	5%
Height		—	—	—	55 m
<b>TRANSITIONAL</b>					
Slope		—	—	—	20%
Height		—	—	—	45 m

a. Slope and length enables helicopters to decelerate for landing while observing "avoid" areas.

b. The width of the inner edge shall be added to this dimension.

c. Determined by the distance from the inner edge to the point where the divergence produces a width of 7 rotor diameters for day operations or 10 rotor diameters for night operations.

d. Seven rotor diameters over-all width for day operations or 10 rotor diameters over-all width for night operations.

e. Determined by the distance from inner edge to where the approach surface reaches a height of 150 m above the elevation of the inner edge.



Table 4-3. Dimensions and slopes of obstacle limitation surfaces

Surface and dimensions		Non-instrument (visual)			Instrument
		Helicopter performance class			
		1	2	3	
<b>STRAIGHT TAKE-OFF</b>					
<b>TAKE-OFF CLIMB</b>					
Width of inner edge Location of inner edge		Width of safety area Boundary or end of clearway			90 m Boundary or end of clearway
<i>First section</i>					
Divergence	— day	10%	10%	10%	30%
	— night	15%	15%	15%	
Length	— day	a	245 m <sup>b</sup>	245 m <sup>b</sup>	2 850 m
	— night	a	245 m <sup>b</sup>	245 m <sup>b</sup>	
Outer width	— day	c	49 m <sup>d</sup>	49 m <sup>d</sup>	1 800 m
	— night	c	73.5 m <sup>d</sup>	73.5 m <sup>d</sup>	
Slope (maximum)		4.5%*	8% <sup>b</sup>	8% <sup>b</sup>	3.5%
<i>Second section</i>					
Divergence	— day	parallel	10%	10%	parallel
	— night	parallel	15%	15%	
Length	— day	e	a	a	1 510 m
	— night	e	a	a	
Outer width	— day	c	c	c	1 800 m
	— night	c	c	c	
Slope (maximum)		4.5%*	15%	15%	3.5%*
<i>Third section</i>					
Divergence		—	parallel	parallel	parallel
Length	— day	—	e	e	7 640 m
	— night	—	e	e	
Outer width	— day	—	c	c	1 800 m
	— night	—	c	c	
Slope (maximum)		—	15%	15%	2%
<p>a. Determined by the distance from the inner edge to the point where the divergence produces a width of 7 rotor diameters for day operations or 10 rotor diameters for night operations.</p> <p>b. Slope and length provides helicopters with an area to accelerate and climb while observing "avoid" areas.</p> <p>c. Seven rotor diameters over-all width for day operations or 10 rotor diameters over-all width for night operations.</p> <p>d. The width of the inner edge shall be added to this dimension.</p> <p>e. Determined by the distance from the inner edge to where the surface reaches a height of 150 m above the elevation of the inner edge.</p>					
* This slope exceeds the maximum mass one-engine-inoperative climb gradient of many helicopters which are currently operating.					

Table 4-4. Criteria for curved take-off climb/approach area  
NON-INSTRUMENT FINAL APPROACH AND TAKE-OFF

Facility	Requirement
Directional change	As required (120° max).
Radius of turn on centre line	Not less than 270 m.
Distance to inner gate*	(a) For performance class 1 helicopters — not less than 305 m from the end of the safety area or helicopter clearway.  (b) For performance class 2 and 3 helicopters — not less than 370 m from the end of the FATO.
Width of inner gate — day	Width of the inner edge plus 20% of distance to inner gate.
— night	Width of the inner edge plus 30% of distance to inner gate.
Width of outer gate — day	Width of inner edge plus 20% of distance to inner gate out to minimum width of 7 rotor diameters.
— night	Width of inner edge plus 30% of distance to inner gate out to a minimum width of 10 rotor diameters.
Elevation of inner and outer gates	Determined by the distance from the inner edge and the designated gradient(s).
Slopes	As given in Tables 4-1 and 4-3.
Divergence	As given in Tables 4-1 and 4-3.
Total length of area	As given in Tables 4-1 and 4-3.

\* This is the minimum distance required prior to initiating a turn after take-off or completing a turn in the final phase.

*Note.— More than one turn may be necessary in the total length of the take-off climb/approach area. The same criteria will apply for each subsequent turn except that the widths of the inner and outer gates will normally be the maximum width of the area.*

**TABLE 4-1**  
**Dimensions and slopes of obstacle limitation surfaces**  
**For All Visual FATOs including FATO/TLOFs**

<b>SLOPE CATEGORIES</b>			
	A	B	C
<b>SURFACE and DIMENSIONS</b>			
<b>APPROACH and TAKE-OFF CLIMB SURFACE:</b>			
Length of inner edge	Width of safety area	Width of safety area	Width of safety area
Location of inner edge	Safety area boundary (Clearway boundary if provided)	Safety area boundary	Safety area boundary
<b>Divergence: (1st &amp; 2nd section)</b>			
Day use only	10%	10%	10%
Night use	15%	15%	15%
<b>First Section:</b>			
Length	(a)	245 m	1220 m
Slope	4.5% (1:22.2)	8% (1:12.5)	12.5% (1:8)
Outer Width	(c)	N/A	(c)
<b>Second Section:</b>			
Length	N/A	830 m	N/A
Slope	N/A	16% (1:6.25)	N/A
Outer Width	N/A	(c)	N/A
Total Length from inner edge (b)	(a)	1075 m	1220 m
<b>Transitional Surface:(FATOs including FATO/TLOFs with a PinS approach procedure with a VSS)</b>			
Slope	50% (1:2)	50% (1:2)	50% (1:2)
Height	45 m	45 m	45 m

(a) Determined by the distance from the inner edge to where the surface reaches a height of 152 m above the elevation of the inner edge. On level ground, this would typically be 3386 m (2.1 SM) in length.

- (b) The approach and take-off climb surface lengths of 3386 m, 1075 m and 1220 m associated with the respective slopes, brings the helicopter to 152 m (500 ft) above FATO (or FATO/TLOF) elevation. This is typically the transition elevation between non-instrument and instrument flight.
- (c) Seven rotor diameters overall width for day operations or 10 rotor diameters overall width for night operations.

*Note.— The slope categories in Table 4-1 may not be restricted to a specific performance class of operation and may be applicable to more than one performance class of operation. The slope categories depicted in Table 4-1 represent minimum design slope angles and not operational slopes. Slope category “A” generally corresponds with helicopters operated in performance class 1; slope category “B” generally corresponds with helicopters operated in performance class 3; and slope category “C” generally corresponds with helicopters operated in performance class 2. Consultation with helicopter operators will help to determine the appropriate slope category to apply according to the heliport environment and the most critical helicopter type for which the heliport is intended.*

---

*Editorial Note.* Renumber Figure 4-2 to Figure 4-7

---

Figure 4-27. Helideck obstacle-free sector

---

*Editorial Note.* Delete existing Figure 4-3. Add new Figure 4-8. Helideck obstacle limitation sectors and surfaces for a 1D FATO/TLOF.

---

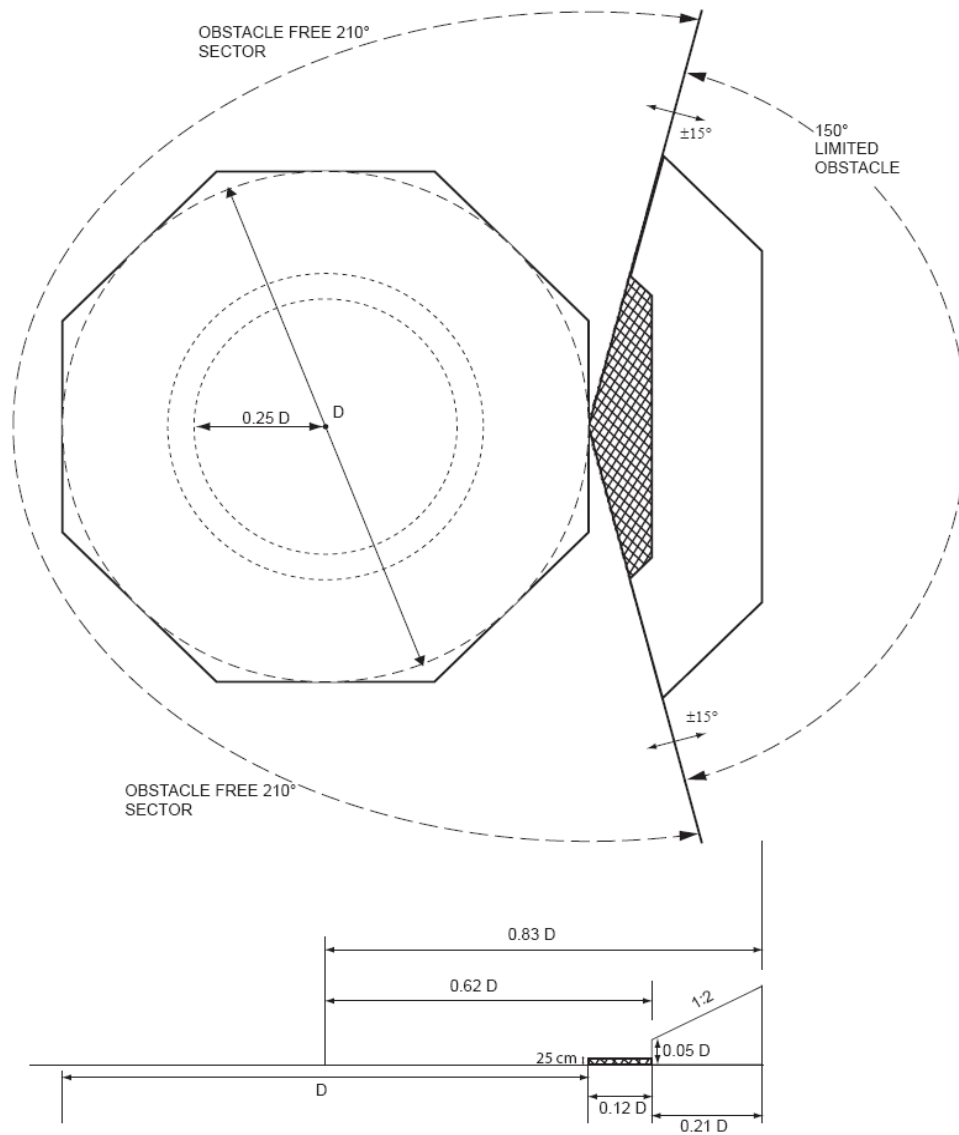


Figure 4-8. Helideck obstacle limitation sectors and surfaces for a 1D FATO/TLOF

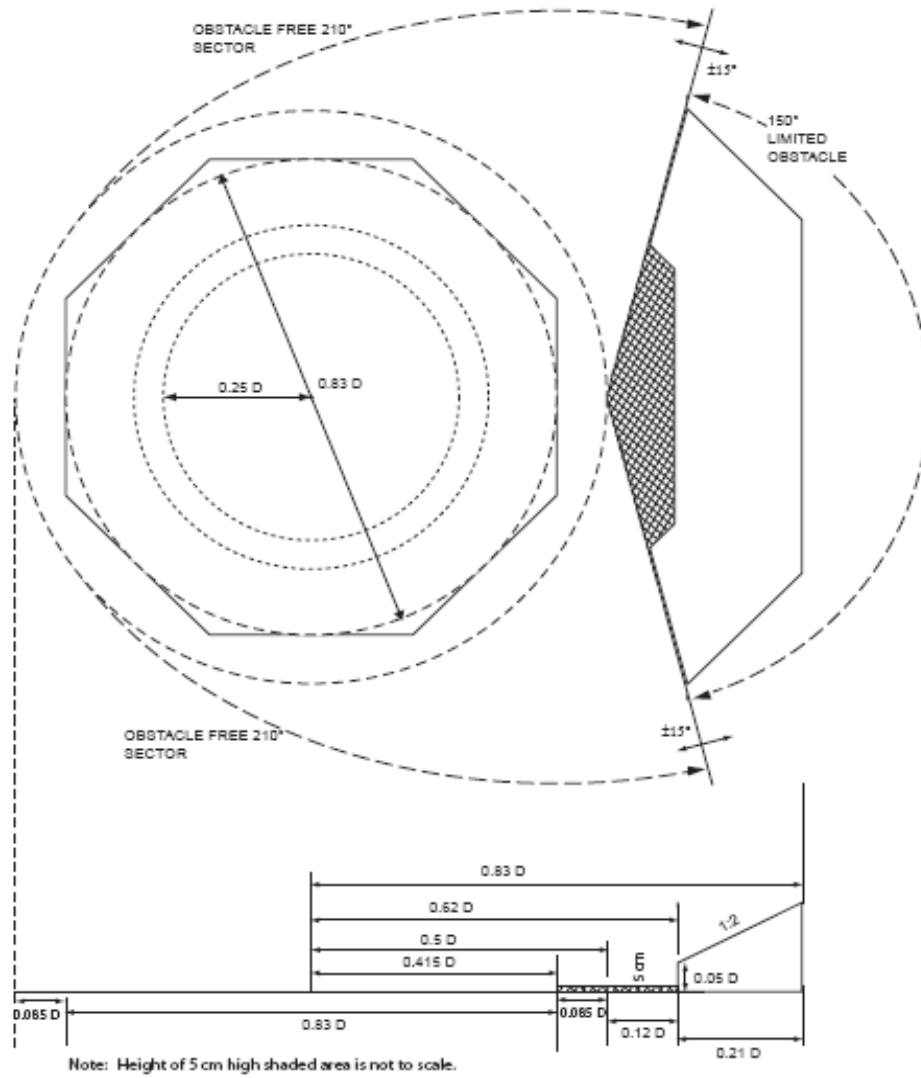


Figure 4-9. Helideck obstacle limitation sectors and surfaces for a 0.83D FATO/TLOF

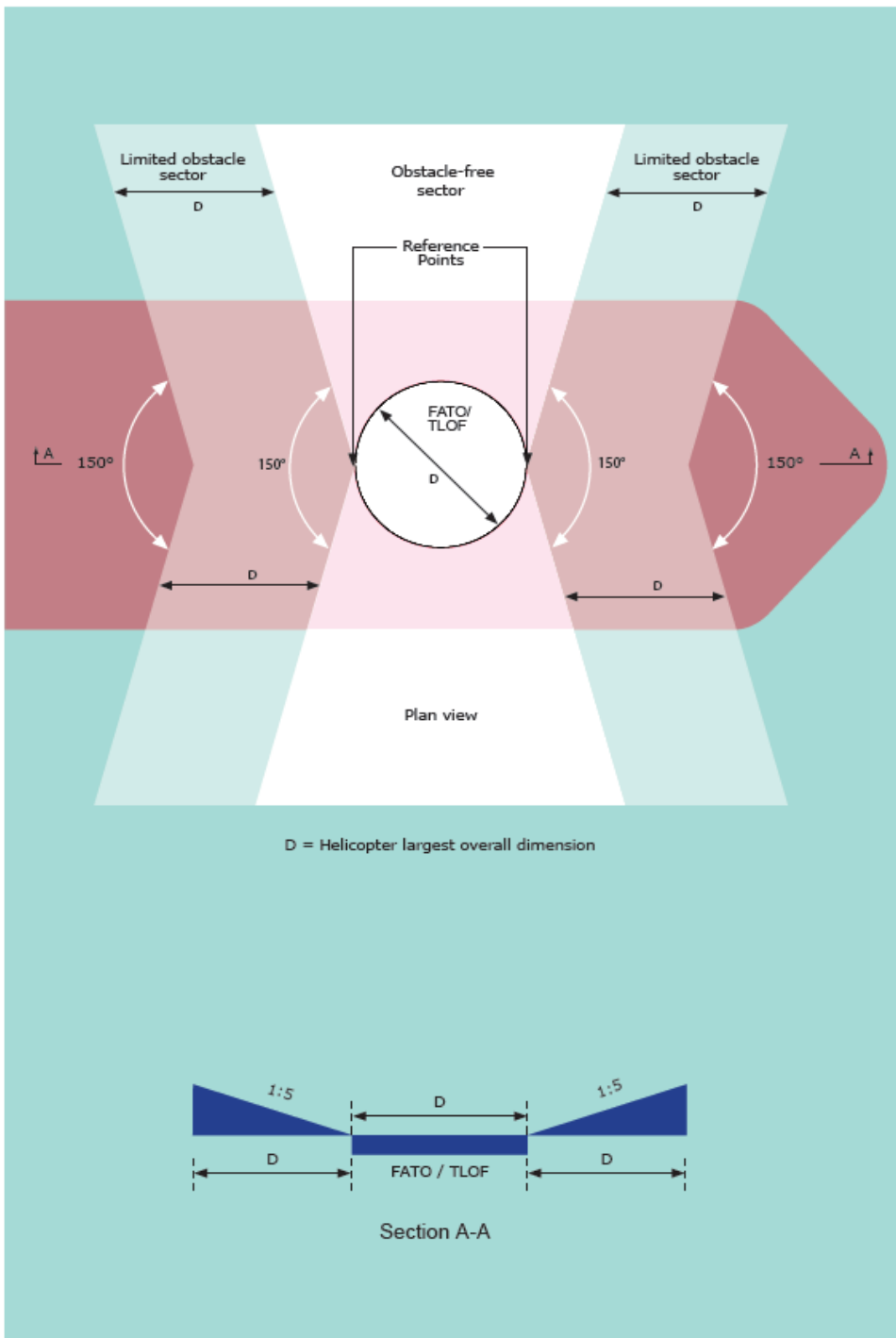


Figure 4-11 Amidships Location - Shipboard Heliport Obstacle Limitation Surfaces

*Editorial Note.* Figure 4-910. Amidships Location – Shipboard Heliport Obstacle Limitation Surfaces

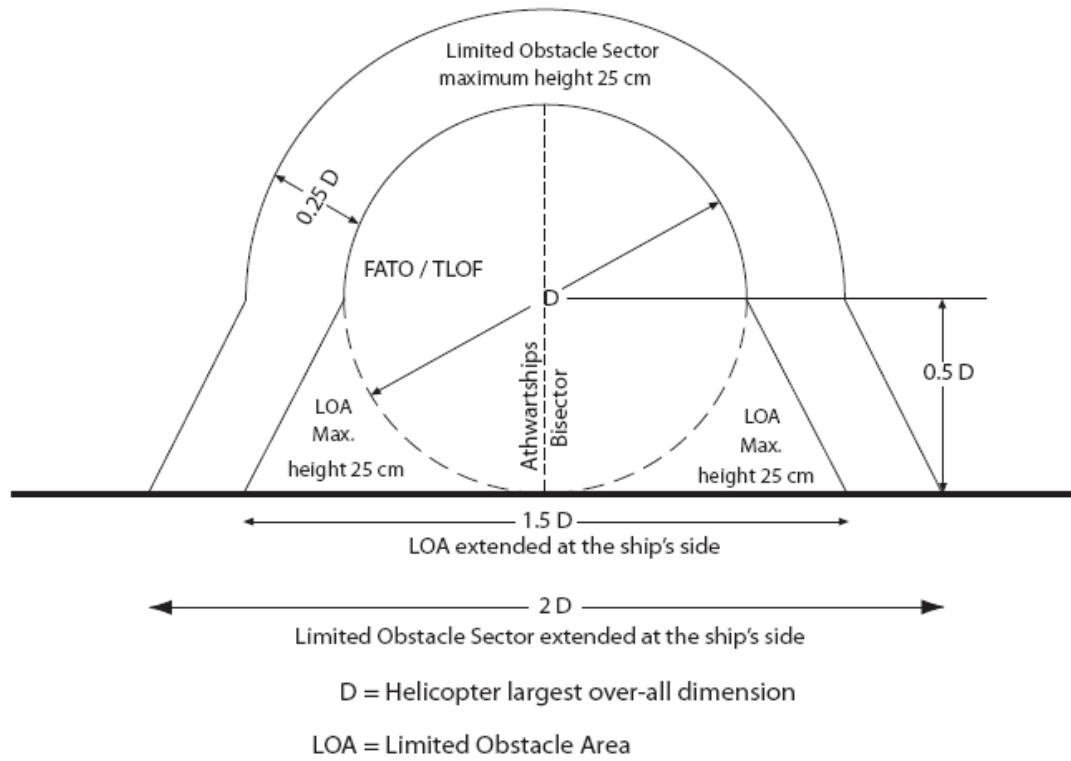


Figure 4.12A Non-Purpose-Built Landing Area: Ship's Side Location -  
Obstacle Limitation Surfaces

---

*Editorial Note.* Figure 4-1011. Ships-side non-purpose built heliport obstacle limitation sectors and surfaces

---



---

*Editorial Note.*— Retain Figure 4-11 as Figure 4-12.

---

## CHAPTER 5. VISUAL AIDS

*Note 1.— The procedures used by some helicopters require that they utilise a FATO having characteristics similar in shape to a runway for fixed wing aircraft. For the purpose of this chapter a FATO having characteristics similar in shape to a runway is considered as satisfying the concept for a "runway-type FATO". For such arrangements it is sometimes necessary to provide specific markings to enable a pilot to distinguish a runway-type FATO during an approach. Appropriate markings are contained within sub-sections entitled "Runway-type FATOs". The requirements applicable to all other types of FATOs are given within sub-sections entitled "All FATOs except runway-type FATOs" and, where indicated, include the requirements for FATO/TLOFs.*

*Note 2.— It has been found that, on surfaces of light colour, the conspicuity of white and yellow markings can be improved by outlining them in black.*

*Note 3.— Guidance is given in the Heliport Manual (doc. 9261) on marking the maximum allowable mass (5.2.3), the D-value (5.2.4) and, if required, the actual FATO Dimension(s) (5.2.5) on the heliport surface to avoid confusion between markings where metric units are used and markings where imperial units are used.*

*Note 4.— For a non-purpose built heliport located on a ship's side the surface colour of the main deck can vary from ship to ship and therefore some discretion may need to be exercised in the colour selection of heliport paint schemes; the objective being to ensure that the markings are conspicuous against the surface of the ship and the operating background.*

### 5.1 Indicators

#### 5.1.1 Wind direction indicators

##### **Application**

5.1.1.1 A heliport shall be equipped with at least one wind direction indicator.

##### **Location**

5.1.1.2 A wind direction indicator shall be located so as to indicate the wind conditions over the FATO or FATO/TLOF and in such a way as to be free from the effects of airflow disturbances caused by nearby objects or rotor downwash. It shall be visible from a helicopter in flight, in a hover or on the movement area.

5.1.1.3 **Recommendation.**— *Where a TLOF or FATO/TLOF may be subject to a disturbed airflow, then additional wind direction indicators located close to the area should be provided to indicate the surface wind on the area.*

*Note.— Guidance on the location of wind direction indicators is given in the Heliport Manual (Doc 9261).*

##### **Characteristics**

5.1.1.4 A wind direction indicator shall be constructed so that it gives a clear indication of the direction of the wind and a general indication of the wind speed.

5.1.1.5 **Recommendation.**— *An indicator should be a truncated cone made of lightweight fabric and should have the following minimum dimensions:*

	Surface level heliports	Elevated heliports and helidecks
<i>Length</i>	<i>2.4 m</i>	<i>1.2 m</i>
<i>Diameter (larger end)</i>	<i>0.6 m</i>	<i>0.3 m</i>
<i>Diameter (smaller end)</i>	<i>0.3 m</i>	<i>0.15 m</i>

5.1.1.6 **Recommendation.**— *The colour of the wind direction indicator should be so selected as to make it clearly visible and understandable from a height of at least 200 m (650 ft) above the heliport, having regard to background. Where practicable, a single colour, preferably white or orange, should be used. Where a combination of two colours is required to give adequate conspicuity against changing backgrounds, they should preferably be orange and white, red and white, or black and white, and should be arranged in five alternate bands the first and last band being the darker colour.*

5.1.1.7 A wind direction indicator at a heliport intended for use at night shall be illuminated.

## 5.2 Markings and markers

*Note.*— See Annex 14 Volume I, 5.2.1.4, Note 1 concerning improving conspicuity of markings

### 5.2.1 Winching area marking

#### **Application**

5.2.1.1 Winching area markings shall be provided at a designated winching area (see Figure 4-14~~2~~).

#### **Location**

5.2.1.2 Winching area markings shall be located so that the centre(s) coincides with the centre of the clear zone of the winching area (see Figure 4-12).

### **Characteristics**

5.2.1.3 Winching area markings shall comprise a winching area clear zone marking and a winching area manoeuvring zone marking.

5.2.1.4 A winching area clear zone marking shall consist of a solid circle of diameter not less than 5 m in diameter and of a conspicuous colour.

5.2.1.5 A winching area manoeuvring zone marking shall consist of a broken circle of line of 0.2m 30 cm in width and of a diameter not less than 2 D and be marked in a conspicuous colour. Within it “WINCH ONLY” shall be marked to be easily visible to the pilot.

### 5.2.2 Heliport identification marking

#### **Application**

5.2.2.1 A heliport identification markings shall be provided at a heliport.

#### **Location - All FATOs except runway-type FATOs**

5.2.2.2 A heliport identification marking shall be located within the FATO, at or near the centre of the area or, when used in conjunction with runway designation markings at each end of the area FATO or FATO/TLOF.

*Note 1.- If the Touchdown/positioning marking is offset on a helideck, the heliport identification marking is established in the centre of the Touchdown/positioning marking.*

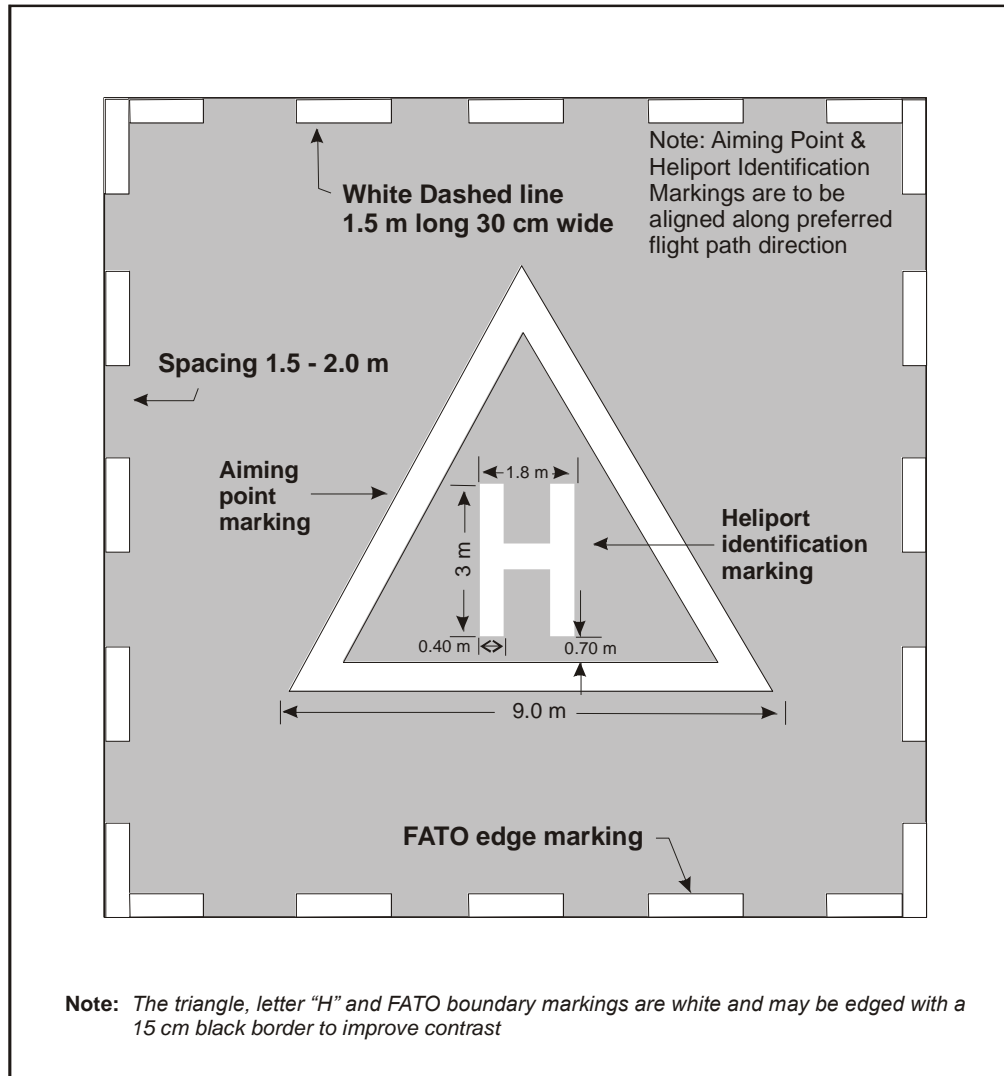
*Note 2.- On a FATO, which does not contain a TLOF and which is marked with an aiming point marking (see 5.2.8), except for a heliport at a hospital, the heliport identification marking is established in the centre of the aiming point marking as shown in Figure 5-1.*

5.2.2.3 On a FATO which contains a TLOF, a heliport identification marking shall be located in the FATO so the position of it coincides with the centre of the TLOF.

---

*Editorial Note.—* Replace figure 5-1 with new Figure 5-1 as follows:

---



**Figure 5-1. Combined heliport identification and aiming point marking**

### **Location - Runway-type FATOs**

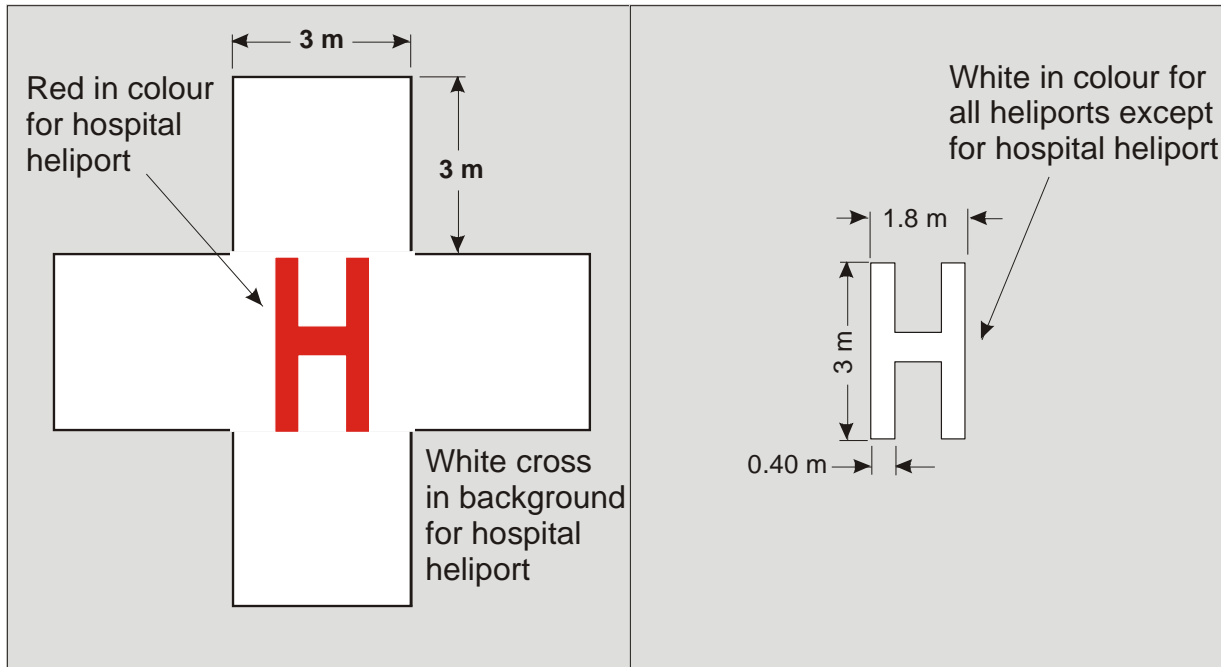
5.2.2.4 A heliport identification marking shall be located in the FATO and when used in conjunction with FATO designation markings, shall be displayed at each end of the FATO as shown in Figure 5-3.

### **Characteristics**

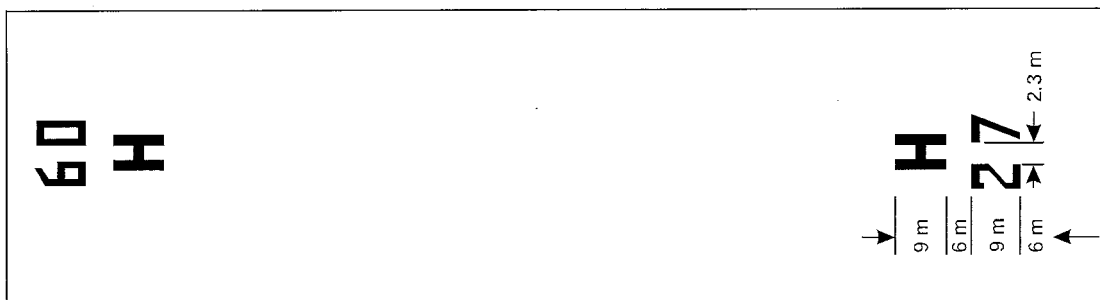
5.2.2.35 A heliport identification marking, except for a heliport at a hospital, shall consist of a letter H, white in colour. The dimensions of the H marking shall be no less than those shown in Figure 5-12 and where the marking is used for a runway-type FATO in conjunction with the FATO designation marking specified in 5.2.6, its dimensions shall be increased by a factor of 3 as shown in Figure 5-3.

5.2.2.46 A heliport identification marking for a heliport at a hospital shall consist of a letter H, red in colour, on a white cross made of squares adjacent to each of the sides of a square containing the H as shown in Figure 5-2.

*Editorial Note.*— Replace Figure 5-2 with new Figure 5-2 as follows:



**Figure 5-2. Hospital heliport identification and heliport identification marking**



**Figure 5-3. FATO designation marking and heliport identification marking for a runway-type FATO**

5.2.2.57 A heliport identification marking shall be oriented with the cross arm of the H at right angles to the preferred final approach direction. For a helideck the cross arm shall be on or parallel to the bisector of the obstacle-free sector as shown in Figure 5-1. For a non-purpose built shipboard heliport located on a ship's side the cross arm shall be parallel with the side of the ship.

5.2.2.68 **Recommendation.**— *On a helideck and shipboard heliport the size of the heliport identification “H” marking should have a height of 4 m with an overall width not exceeding 3 m and a stroke width not exceeding 0.75 m.*

### 5.2.3 Maximum allowable mass marking

#### **Application**

5.2.3.1 **Recommendation.**— *A maximum allowable mass marking should shall be displayed at an elevated heliport, and at a helideck and a shipboard heliport.*

*Note.*— *For an elevated heliport, a helideck or a shipboard heliport designed with a FATO/TLOF of less than 1 D, the maximum allowable mass may be no greater than 3175 kg or 7000 lb.*

5.2.3.2 **Recommendation.**— *A maximum allowable mass marking should be displayed at a surface level heliport.*

#### **Location**

5.2.3.23 **Recommendation.**— *A maximum allowable mass marking should be located within the TLOF FATO or FATO/TLOF and so arranged as to be readable from the preferred final approach direction.*

#### **Characteristics**

5.2.3.34 A maximum allowable mass marking shall consist of a one-, two- or three-digit number. The marking shall be expressed in tonnes (1,000 kg) rounded to the nearest 1000 kg followed by a letter “t”. Where States use mass in pounds, the maximum allowable mass marking shall indicate the allowable helicopter mass in thousands of pounds rounded to the nearest 1000 lbs.

5.2.3.5 The maximum allowable mass shall be expressed in tonnes (1,000 kg) rounded to the nearest 1000 kg followed by a letter “t”. Where States use mass in pounds, the maximum allowable mass marking shall indicate the allowable helicopter mass in thousands of pounds rounded to the nearest 1000 lbs.

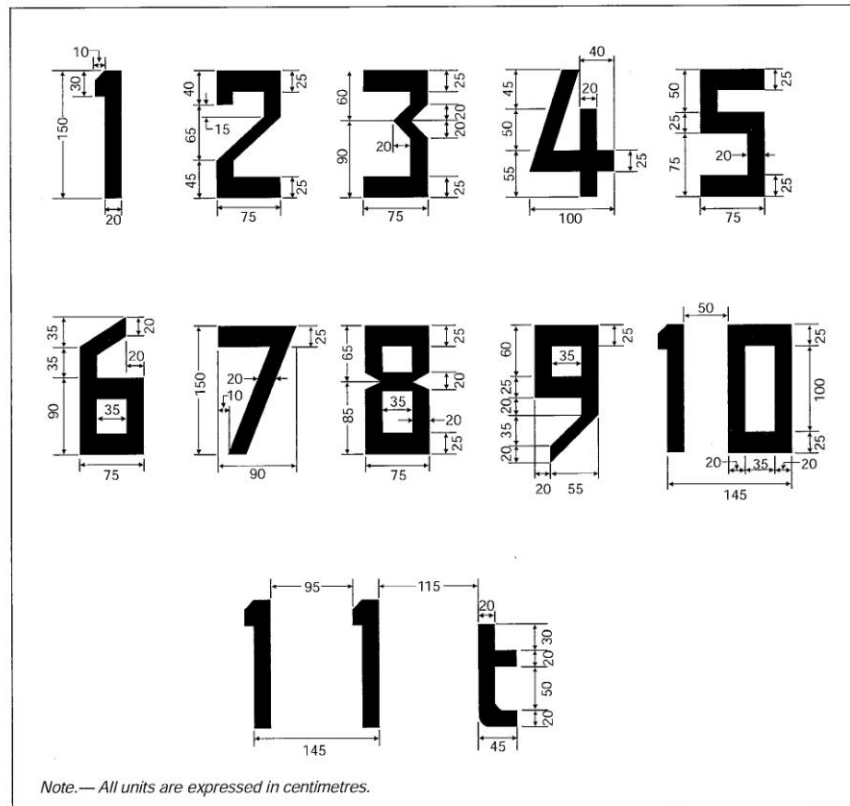
*Note.*— *Where States express the maximum allowable mass in pounds, it is not appropriate to suffix with the letter “t” which is used only to indicate metric tonnes. Guidance on markings where States use imperial units is given in the Heliport Manual (Doc 9261).*

5.2.3.46 **Recommendation.**— *The maximum allowable mass marking should be expressed to the nearest 100 kg. The marking should be presented to one decimal place and rounded to the nearest 100 kg followed by the letter “t”. Where States use mass in pounds, the maximum allowable mass marking should indicate the allowable helicopter mass in hundreds of pounds rounded to the nearest 100 lb.*

---

*Editorial Note.*— *Figure 5-2 moved and renumbered Figure 5-4 as follows:*

---



**Figure 5-24. Form and proportions of numbers and letters for maximum allowable mass marking**

**5.2.3.6A Recommendation.**— When the maximum allowable mass is expressed to 100 kg, the decimal place should be preceded with a decimal point marked with a 30 cm square.

*All FATOs except runway-type FATOs*

**5.2.3.57 Recommendation.**— The numbers and the letter of the marking should have a colour contrasting with the background and should be in the form and proportion shown in Figure 5-24, ~~except that~~ where space is limited, such as on an offshore helideck or shipboard heliport, it is permitted to reduce the size of the marking to characters with an overall height of not less than 90 cm with a corresponding reduction in the width and thickness of the figures for a FATO or FATO/TLOF with a dimension of more than 30 m. For a FATO or FATO/TLOF with a dimension of between 15 m to 30 m the height of the numbers and the letter of the marking should be a minimum of 90 cm, and for a FATO or FATO/TLOF with a dimension of less than 15 m the height of the numbers and the letter of the marking should be a minimum of 60 cm, each with a corresponding reduction in width and thickness.

*Runway-type FATOs*

5.2.3.8 **Recommendation.**— *The numbers and the letter of the marking should have a colour contrasting with the background and should be in the form and proportion shown in Figure 5-4.*

5.2.4 ~~Maximum allowable~~ D-value marking*Application*

5.2.4.1 **Recommendation.**— *The D-value marking should be displayed at an elevated heliport and at a helideck.*

*All FATOs except runway-type FATOs*

5.2.4.1 The D-value marking shall be displayed at a heliport designed for helicopters operated in performance Class 2 or 3, and at a helideck and at a shipboard heliport.

*Runway-type FATOs*

*Note.* —*The D-value is not required to be marked on a heliport with a runway-type FATO.*

*Location*

5.2.4.2 **Recommendation.**— A ~~maximum allowable~~ D-value marking ~~should~~ shall be located within the FATO or FATO/TLOF and so arranged as to be readable from the preferred final approach direction.

5.2.4.3 **Recommendation.**— *Where there is more than one approach direction, additional D-value markings should be provided such that at least one D-value marking is readable from the final approach directions. For a non-purpose built heliport located on a ship's side, D value markings should be provided on the perimeter of the D circle at the 2 o'clock, 10 o'clock and 12 o'clock positions when viewed from the side of the ship facing towards the centreline.*

*Characteristics*

5.2.4.34 The D-value shall be marked on the FATO or FATO/TLOF in a ~~contrasting colour to it,~~ preferably white. The D-value shall be rounded to the nearest whole ~~number~~ metre or foot with 0.5 rounded down. ~~e.g. 19.5 becomes 19 and 19.6 becomes 20.~~

5.2.4.5 **Recommendation.**— *The numbers of the marking should have a colour contrasting with the background and should be in the form and proportion shown in Figure 5-4 for a FATO or FATO/TLOF with a dimension of more than 30 m. For a FATO or FATO/TLOF with a dimension of between 15 m to 30 m the height of the numbers of the marking should be a minimum of 90 cm, and for a*

*FATO or FATO/TLOF with a dimension of less than 15 m the height of the numbers of the marking should be a minimum of 60 cm, each with a corresponding reduction in width and thickness.*

---

*Editorial Note.*— New sub-section on marking the actual FATO dimensions as follows:

---

### 5.2.5 Final approach and take-off dimension(s) marking

#### **Application**

**5.2.5.1 Recommendation.**—*The actual dimension(s) of the FATO or FATO/TLOF intended to be used by helicopters operated in performance class 1 should be marked on the FATO or FATO/TLOF.*

**5.2.5.2 Recommendation.**—*If the actual dimension(s) of the FATO or FATO/TLOF to be used by helicopters operated in performance class 2 or 3 is less than 1D, the dimension(s) should be marked on the FATO or FATO/TLOF.*

#### **Location**

**5.2.5.3** A FATO or FATO/TLOF size marking shall be located within the FATO and so arranged as to be readable from the preferred final approach direction.

#### **Characteristics**

**5.2.5.4** The dimension(s) shall be rounded to the nearest metre or foot.

*Note.*— *If the FATO or FATO/TLOF is square or rectangular both the length and width of the FATO or FATO/TLOF relative to the preferred final approach direction is indicated.*

#### **All FATOs except runway-type FATOs**

**5.2.5.5 Recommendation.**— *The numbers of the marking should have a colour contrasting with the background and should be in the form and proportion shown in Figure 5-4 for a FATO or FATO/TLOF with a dimension of more than 30 m. For a FATO or FATO/TLOF with a dimension between 15 m to 30 m the height of the numbers of the marking should be a minimum of 90 cm, and for a FATO or FATO/TLOF with a dimension of less than 15 m the height of the numbers of the marking should be a minimum of 60 cm, each with a corresponding reduction in width and thickness.*

#### **Runway-type FATOs**

**5.2.5.6 Recommendation.**— *The numbers of the marking should have a colour contrasting with the background and should be in the form and proportion shown in Figure 5-4.*

### 5.2.56 Final approach and take-off area perimeter marking or markers for surface level heliports

#### *Application*

5.2.56.1 FATO perimeter marking or markers shall be provided at a surface level heliport ~~on ground~~ where the extent of the FATO is not self-evident.

#### *Location*

5.2.56.2 The FATO perimeter marking or markers shall be located on the boundary edge of the FATO.

#### *Characteristics - Runway-type FATOs*

5.2.56.3 The perimeter of the FATO shall be defined with markings or markers ~~shall be spaced:~~

- a) ~~for a square or rectangular area, at equal intervals of not more than 50 m with at least three markings or markers on each side including a marking or marker at each corner; and~~
- b) ~~for any other shaped area, including a circular area, markings or markers shall be spaced at equal intervals of not more than 10 m with a minimum number of five markings or markers.~~

5.2.56.4 A FATO perimeter marking shall be a rectangular stripe with a length of 9 m or one-fifth of the side of the FATO which it defines and a width of 1 m. ~~Where a marker is used its characteristics shall conform to those specified in Annex 14, Volume I, 5.5.8.3 except that the height of the marker shall not exceed 25 cm above ground or snow level.~~

5.2.56.5 A FATO perimeter markings shall be white.

5.2.6.6 A FATO perimeter marker shall have dimensional characteristics as shown in Figure 5-5.

5.2.6.7 FATO perimeter markers shall be of colour(s) that contrast effectively against the operating background.

5.2.6.8 **Recommendation.**— FATO perimeter markers should be a single colour, orange or red, or two contrasting colours, orange and white or alternatively red and white should be used except where such colours would merge with the background.

#### *Characteristics - All FATOs except runway-type FATOs*

5.2.6.9 For an unpaved FATO the perimeter shall be defined with flush in-ground markers. The FATO perimeter markers shall be 30 cm in width, 1.5 m in length, and with end-to-end spacing of not less than 1.5 m and not more than 2 m. The corners of a square or rectangular FATO shall be defined.

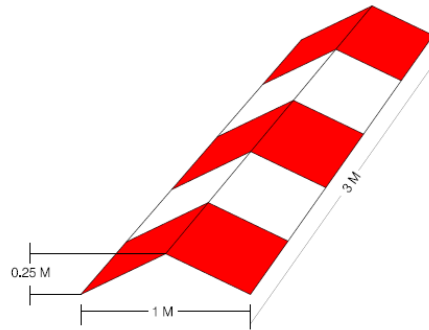
5.2.6.10 For a paved FATO the perimeter shall be defined with a dashed line. The FATO perimeter marking segments shall be 30 cm in width, 1.5 m in length, and with end-to-end spacing of not less than 1.5 m and not more than 2 m. The corners of the square or rectangular FATO shall be defined.

5.2.6.11 FATO perimeter markings and flush in-ground markers shall be white.

---

*Editorial Note.— New Figure 5-5:*

---



**Figure 5-5 Runway-type FATO edge marker**

5.2.67 Final approach and take-off area designation markings for runway-type FATO

#### **Application**

5.2.67.1 **Recommendation.**— A FATO designation marking should be provided at a heliport where it is necessary to designate the FATO to the pilot.

#### **Location**

5.2.67.2 A FATO designation marking shall be located at the beginning of the FATO as shown in Figure 5-3.

#### **Characteristics**

5.2.67.3 A FATO designation marking shall consist of a ~~runway designation marking described in Annex 14, Volume I, 5.2.2.4 and 5.2.2.5,~~ two-digit number. The two-digit number shall be the whole number nearest the one-tenth of the magnetic North when viewed from the direction of approach. When the above rule would give a single digit number, it shall be preceded by a zero. The marking as shown in Figure 5-3, shall be supplemented by an H, specified in 5.2.2.5 above, and as shown in Figure 5-3.

## 5.2.78 Aiming point marking

**Application**

5.2.78.1 **Recommendation.**— An aiming point marking should be provided at a heliport where it is necessary for a pilot to make an approach to a particular point above a FATO before proceeding to the TLOF.

**Location - Runway-type FATOs**

5.2.78.2 The aiming point marking shall be located within the FATO.

**Location - All FATOs except runway-type FATOs**

5.2.8.3 The aiming point marking shall be located at the centre of the FATO as shown in Figure 5-1.

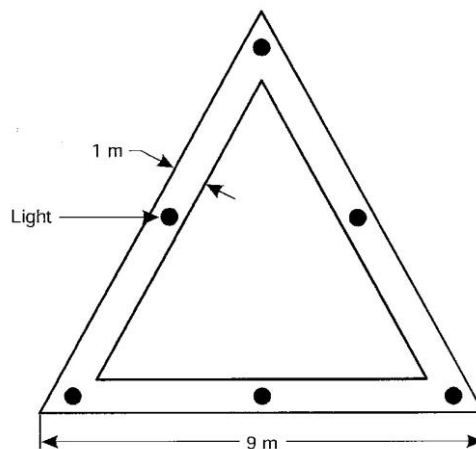
**Characteristics**

5.2.78.3.4 The aiming point marking shall be an equilateral triangle with the bisector of one of the angles aligned with the preferred approach direction. The marking shall consist of continuous white lines, and the dimensions of the marking shall conform to those shown in Figure 5-46.

---

*Editorial Note.*— Figure 5-4 renumbered Figure 5-6 as follows:

---



**Figure 5-46. Aiming point marking**

## 5.2.89 Touchdown and lift-off area perimeter marking

**Application**

5.2.8.1—TLOF marking shall be provided on a heliport if the perimeter of the TLOF is not self-evident.

5.2.9.1 A TLOF perimeter marking shall be displayed on a TLOF located in a FATO at a surface level heliport if the perimeter of the TLOF is not self-evident.

5.2.9.2 A TLOF perimeter marking shall be displayed on an elevated heliport, a helideck and a shipboard heliport.

5.2.9.3 **Recommendation.**— A TLOF perimeter marking should be provided on each TLOF collocated with a helicopter stand at a surface level heliport.

**Location**

5.2.89.24 The TLOF perimeter marking shall be located along the perimeter edge of the TLOF or FATO/TLOF.

**Characteristics**

5.2.89.35 A TLOF perimeter marking shall consist of a continuous white line with a width of at least 30 cm.

## 5.2.910 Touchdown/positioning marking

**Application**

5.2.910.1 A touchdown/positioning marking shall be provided where it is necessary for a helicopter to touch down ~~or~~ and/or be accurately ~~placed~~ positioned by the pilot ~~in a specific position~~. A touchdown/positioning marking shall be provided on a helicopter stand designed for turning.

**Location**

5.2.910.2 A touchdown/positioning marking shall be located so that when the pilot's seat is over the marking, the whole of the undercarriage will be ~~inside~~ within the ~~load-bearing area~~, TLOF or FATO/TLOF and all parts of the helicopter will be clear of any obstacle by a safe margin.

5.2.10.3 On a heliport the centre of the touchdown/positioning marking shall be located at the centre of the TLOF or FATO/TLOF, except the centre of the touchdown/positioning marking may be offset away from the centre of the TLOF or FATO/TLOF where an aeronautical study indicates such offsetting to be necessary and providing that a marking so offset would not adversely affect safety. For a

helicopter stand designed for hover turning, the touchdown/positioning marking shall be located in the centre of the central zone (see Figure 3-4).

5.2.910.34 On a helideck the centre of the touchdown/positioning marking shall be located at the centre of the FATO/TLOF, except that the marking centre may be offset away from the origin of the obstacle-free sector by no more than 0.1 D on helidecks with a FATO/TLOF of 1 D or greater where an aeronautical study indicates such offsetting to be necessary and providing that a marking so offset would not adversely affect the safety. For heliports located on the bow of a vessel, and for any helideck or shipboard heliport where the D value is 16.0m or less, the touchdown/positioning marking shall be located at the centre of the FATO/TLOF.

*Note. See Heliport Manual (Doc 9261) for guidance.*

~~*Note.— It is not considered appropriate to offset a touchdown marking on a heliport located on the bow of a vessel, or for any helideck where the D value is 16 m or less.*~~

### Characteristics

5.2.910.45 A touchdown/positioning marking shall be a yellow circle and have a line width of at least 0.5 m. For a helideck and a purpose built shipboard heliport the line width shall be at least 1 m.

5.2.910.56 The inner diameter of the circle touchdown/positioning marking shall be 0.5 D of the largest helicopter the TLOF and/or FATO/TLOF and/or the helicopter stand is intended to serve.

~~5.2.9.6 When a net is located on the surface of a FATO, it shall be large enough to cover the whole of the touchdown/positioning marking and shall not obscure other essential markings.~~

## 5.2.4011 Heliport name marking

### Application

5.2.4011.1 **Recommendation.**— A heliport name marking should be provided at a heliport and helideck where there is insufficient alternative means of visual identification.

### Location

5.2.4011.2 **Recommendation.**— The heliport name marking should be placed displayed on the heliport so as to be visible, as far as practicable, at all angles above the horizontal. Where an obstacle sector exists on a helideck the marking should be located on the obstacle side of the H identification marking. For a non-purpose built heliport located on a ship's side the marking should be located on the inboard side of the H identification marking in the area between the continuous line TLOF perimeter marking and the broken line indicating the boundary of the LOS.

### Characteristics

5.2.4011.3 A heliport name marking shall consist of the name or the alphanumeric designator of the heliport as used in the radiotelephony (R/T) communications.

---

*Editorial Note.*— 5.2.10.4 has been relocated to new 5.2.11.5 below.

---

5.2.10.4 ~~5.2.11.5~~ **Recommendation.**— *A heliport name marking intended for use at night or during conditions of poor visibility shall should be illuminated, either internally or externally.*

#### *Runway-type FATOs*

5.2.10.4 ~~5.2.11.5~~ **Recommendation.**— *The characters of the marking should be not less than 3 m in height at surface level heliports and not less than 1.2 m on elevated heliports and helidecks. The colour of the marking should contrast with the background.*

#### *All FATOs except runway-type FATOs*

5.2.11.6 **Recommendation.**— *The characters of the marking should be not less than 1.5 m in height at surface level heliports and not less than 1.2 m on elevated heliports, helidecks and shipboard heliports. The colour of the marking should contrast with the background and preferably be white.*

#### 5.2.11.12 Helideck obstacle-free sector (chevron) marking

##### ***Application***

5.2.11.12.1 **Recommendation.**— *A helideck obstacle-free sector marking should be provided at a helideck. A helideck with adjacent obstacles that penetrate above the level of the helideck shall have an obstacle free sector marking.*

##### ***Location***

5.2.11.12.2 A helideck obstacle-free sector marking shall be located, where practicable, at a distance from the centre of the FATO/TLOF equal to the radius of the largest circle that can be drawn in the FATO/TLOF on the FATO perimeter or on the TLOF marking or 0.5D, whichever is greater.

*Note.*— *Where the Point of Origin is outside the FATO/TLOF, and it is not practicable to physically paint the chevron, the chevron is relocated to the perimeter on the bisector of the OFS. In this case the distance and direction of displacement, along with the attention getting “WARNING DISPLACED CHEVRON”, with the distance and direction of displacement, is marked in a box beneath the chevron in black characters not less than 10cm high – an example Figure is given in the Heliport Manual.*

**Characteristics**

5.2.12.3 The helideck obstacle-free sector marking shall indicate the origin location of the obstacle-free sector and the directions of the limits of the sector. Example figures are given in the Heliport Manual (Doc 9261).

*Note. Example figures are given in the Heliport Manual (Doc 9261).*

5.2.12.4 The height of the chevron shall equal the width of the TLOF marking but shall be not be less than 30 cm.

5.2.12.5 The chevron shall be marked in a conspicuous colour.

**5.2.12.6 Recommendation.** — *The colour of the Chevron should be black.*

### 5.2.13 Helideck and shipboard heliport surface marking

**Application**

**5.2.13.1 Recommendation.**— *A surface marking should be provided to assist the pilot to identify the location of the helideck or shipboard heliport during an approach by day.*

**Location**

**5.2.13.2 Recommendation.**— *A surface marking should be applied to the dynamic load bearing area bounded by the TLOF perimeter marking.*

**Characteristics**

**5.2.13.3 Recommendation.**— *The helideck or shipboard heliport surface bounded by the FATO/TLOF perimeter marking should be of a dark colour green using a high friction coating. Where the surface coating may have a degrading effect on friction qualities, it may be necessary to leave the helideck surface untreated. In such cases, the conspicuity of the markings should be enhanced by outlining the deck markings with a contrasting colour.*

*Note.*— *Where the application of a surface coating may have a degrading effect on friction qualities it may be necessary to leave the surface unpainted. In such cases the conspicuity of markings will need to be enhanced by outlining deck markings with a contrasting colour.*

### 5.2.14 Helideck prohibited landing sector markings

**Application**

**5.2.14.1 Recommendation.**— *Helideck prohibited landing sector markings should be provided where it is necessary to prevent the helicopter from landing within specified headings.*

**Location**

5.2.13 5.2.14.2 **Recommendation.**— The prohibited landing sector markings should shall be located on the touchdown/positioning marking to the edge of the FATO/TLOF, within the relevant headings as shown in Figure 5-5.

**Characteristics**

5.2.13 5.2.14.3 The prohibited landing sector markings shall be indicated by white and red hatched markings as shown in Figure 5-57.



Figure 5.57 Helideck prohibited landing sector markings

*Note.*— Prohibited landing sector markings, where deemed necessary, are applied to indicate a range of helicopter headings that are not to be used by a helicopter when landing. This is to ensure that the nose of the helicopter is kept clear of the hatched markings during the manoeuvre to land.

#### 5.2.14 — Markings and markers for helicopter taxiways

*Note.*— ~~The specifications for taxiway centre line marking and taxi holding position markings in Annex 14, Volume I, 5.2.8 and 5.2.9 are equally applicable to taxiways intended for ground taxiing of helicopters.~~

#### 5.2.15 Helicopter ground taxiway markings and markers

*Note 1.*— ~~The specifications for taxi-holding position markings in Annex 14, Volume I, 5.2.10 are equally applicable to taxiways intended for ground taxiing of helicopters.~~

*Note 2.- Ground taxi-routes are not required to be marked.*

### ***Application***

5.2.15.1. **Recommendation.** -- *The centre line of a ground taxiway should be identified with a marking and the edges of a ground taxiway, if not self evident, should be identified with markers or markings.*

### ***Location***

5.2.15.2 Ground taxiway markings shall be along the centre line and, if required, along the edges of a ground taxiway.

5.2.15.3 Ground taxiway edge markers shall be located at a distance of 0.5m to 3m beyond the edge of the taxiway.

5.2.15.4 Ground taxiway edge markers, where provided, shall be spaced at intervals of not more than 15 m on each side of straight sections and 7.5 m on each side of curved sections with a minimum of four equally spaced markers per section.

### ***Characteristics***

5.2.15.5 A ground taxiway centre line marking shall be a continuous yellow line 15 cm in width.

5.2.15.6 Ground taxiway edge markings shall be a continuous double yellow line, each 15 cm in width, and spaced 15 cm apart (nearest edge to nearest edge).

*Note.- Signage may be required on an aerodrome where it is necessary to indicate that a ground taxiway is suitable only for the use of helicopters.*

5.2.15.7 A ground taxiway edge marker shall be frangible.

5.2.15.8 A ground taxiway edge marker shall not exceed a plane originating at a height of 25 cm above the plane of the ground taxiway, at a distance of 0.5m from the edge of the taxiway and sloping upwards and outwards at a gradient of 5 per cent to a distance of 3m beyond the edge of the ground taxiway.

5.2.15.9 A ground taxiway edge marker shall be blue.

*Note 1.- Guidance on suitable edge markers is given in the Heliport Manual (Doc 9261).*

*Note 2.- If blue markers are used on an aerodrome, signage may be required to indicate that the ground taxiway is suitable only for helicopters.*

5.2.15.10 If the ground taxiway is to be used at night, the edge markers shall be internally illuminated or retro-reflective.

5.2.1516 Helicopter Air taxiway markings and markers

*Note.- Air taxi-routes are not required to be marked.*

**Application**

~~5.2.15.1 **Recommendation.**— An air taxiway should be marked with air taxiway markers.~~

5.2.16.1. **Recommendation.** -- *The centre line of an air taxiway or, if not self evident, the edges of an air taxiway should be identified with markers or markings.*

*Note.— These markers are not meant to be used on helicopter ground taxiways.*

**Location**

~~5.2.15.2.2 An Air taxiway centre line marking or flush in-ground centreline markers shall be located along the centre line of the air taxiway and shall be spaced at intervals of not more than 30 m on straight sections and 15 m on curves.~~

5.2.16.3 Air taxiway edge markers shall be located at a distance of 1 m to 3m beyond the edge of the air taxiway.

5.2.16.4 **Recommendation.**— *Air taxiway edge markers should not be located at a distance of less than 0.5 of the largest overall width of the helicopter for which designed from the centre line of the air taxiway.*

**Characteristics**

5.2.16.5 An air taxiway centre line, when on a paved surface, shall be marked with a continuous yellow line 15 cm in width

5.2.16.6 The edges of an air taxiway, when on a paved surface, shall be marked with continuous double yellow lines each 15 cm in width, and spaced 15 cm apart (nearest edge to nearest edge).

*Note.- Where there is potential for an air taxiway to be confused with a ground taxiway, signage may be required to indicate the mode of taxi operations that are permitted.*

5.2.16.7 An air taxiway centre line, when on an unpaved surface that will not accommodate painted markings, shall be marked with flush in-ground 15 cm wide and approximately 1.5 m in length yellow markers, spaced at intervals of not more than 30 m on straight sections and not more than 15 m on curves, with a minimum of four equally spaced markers per section.

5.2.16.8 Air taxiway edge markers, where provided, shall be spaced at intervals of not more than 30 m on each side of straight sections and not more than 15 m on each side of curves, with a minimum of four equally spaced markers per section.

5.2.16.9 Air taxiway edge markers shall be frangible.

5.2.16.10 Air taxiway edge markers shall not penetrate a plane originating at a height of 25 cm above the plane of the taxiway, at a distance of 1 m from the edge of the taxiway and sloping upwards and outwards at a gradient of 5 per cent to a distance of 3m beyond the edge of the air taxiway.

5.2.16.11 **Recommendation.**— *Air taxiway edge markers should not penetrate a plane originating at a height of 25 cm above the plane of the taxiway, at a distance of 0.5 of largest overall width of the helicopter for which designed from the centre line of the taxiway, and sloping upwards and outwards at a gradient of 5 per cent.*

~~5.2.15.3~~ An air taxiway marker shall be frangible and when installed shall not exceed 35 cm above ground or snow level. The surface of the marker as viewed by the pilot shall be a rectangle with a height to width ratio of approximately 3 to 1 and shall have a minimum area of 150 cm<sup>2</sup> as shown in Figure 5-6.

~~5.2.15.4~~ 5.2.16.412 An air taxiway edge marker shall be divided into three equal, horizontal bands coloured yellow, green and yellow, respectively. If the air taxiway is to be used at night, the markers shall be internally illuminated or retro-reflective of colour(s) that contrast effectively against the operating background. The colour red shall not be used for markers.

*Note.- Guidance for suitable edge markers is given in the Heliport Manual (Doc 9261).*

5.2.16.13 If the air taxiway is to be used at night, air taxiway edge markers shall be either internally illuminated or retro-reflective.

---

*Editorial Note.*— Current Figure 5-6 to be deleted.

---

## 5.2.16 Air transit route markers.

### ***Application***

~~5.2.16.1~~ **Recommendation.**— *When established an air transit route should be marked with air transit route markers.*

### ***Location***

5.2.16.2 Air transit route markers shall be located along the centre line of the air transit route and shall be spaced at intervals of not more than 60 m on straight sections and 15 m on curves.

### ***Characteristics***

~~5.2.16.3~~ An air transit route marker shall be frangible and when installed shall not exceed 1m above ground or snow level. The surface of the marker as viewed by the pilot shall be a rectangle with a height to width ratio of approximately 1 to 3 and shall have a minimum area of 1500 cm<sup>2</sup> as shown in the examples in Figure 5-7.

~~5.2.16.4—An air transit route marker shall be divided into three equal, vertical bands coloured yellow, green blue and yellow, respectively. If the air transit route is to be used by night, the marker shall be internally illuminated or retro reflective.~~

---

*Editorial Note.*— Current Figure 5-7 to be deleted.

---

---

*Editorial Note.*— New sub-section on marking a Helicopter Stand

---

### 5.2.17 Helicopter stand markings

#### ***Application***

5.2.17.1 A helicopter stand perimeter marking shall be provided on a helicopter stand designed for turning. If a helicopter stand perimeter marking is not practicable, a central zone perimeter marking shall be provided instead if the perimeter of the central zone is not self-evident.

5.2.17.2 For a helicopter stand intended to be used for taxi-through and which does not allow the helicopter to turn, a stop line shall be provided.

5.2.17.3 **Recommendation.** - *Alignment lines and lead-in/lead-out lines should be provided on a helicopter stand.*

*Note 1.— See Figure 5-8.*

*Note 2.- Helicopter stand identification markings may be provided where there is a need to identify individual stands.*

*Note 3.- Additional markings relating to stand size may be provided. See Heliport Manual (Doc 9261).*

#### ***Location***

5.2.17.4 A helicopter stand perimeter marking on a helicopter stand designed for turning or, a central zone perimeter marking, shall be concentric with the central zone of the stand.

5.2.17.5 For a helicopter stand intended to be used for taxi-through and which does not allow the helicopter to turn, a stop line shall be located on the taxiway axis at right angles to the centreline.

5.2.17.6 Alignment lines and lead-in/lead-out lines shall be located as shown in Figure 5-8.

**Characteristics**

5.2.17.7 A helicopter stand perimeter marking shall be a yellow circle and have a line width of 15 cm.

5.2.17.8 A central zone perimeter marking shall be a yellow circle and have a line width of 15 cm, except when the TLOF is collocated with a helicopter stand, the characteristics of the TLOF perimeter markings shall apply.

5.2.17.9 *For a helicopter stand intended to be used for taxi-through and which does not allow the helicopter to turn, a yellow stop line shall not be less than the width of the taxiway and have a line thickness of 50 cm.*

5.2.17.10 Alignment lines and lead-in/lead-out lines shall be continuous yellow lines and have a width of 15 cm.

5.2.17.11 Curved portions of alignment lines and lead-in/lead-out lines shall have radii appropriate to the most demanding helicopter type the helicopter stand is intended to serve.

5.2.17.12. Stand identification markings shall be marked in a contrasting colour so as to be easily readable.

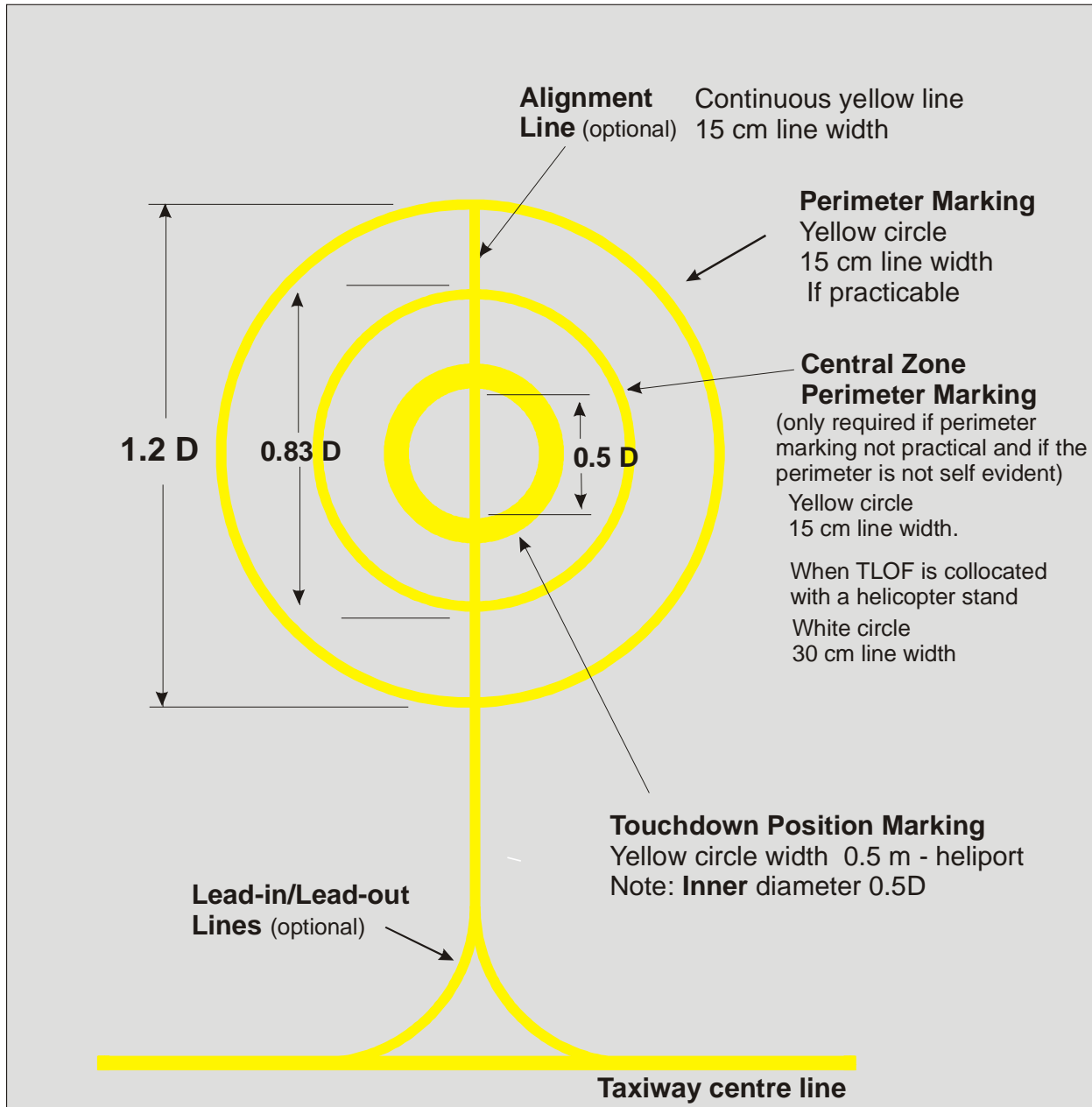
*Note 1.- Where it is intended that helicopters proceed in one direction only, arrows indicating the direction to be followed may be added as part of the alignment lines.*

*Note 2.- The characteristics of markings related to the stand size, and alignment and lead-in/lead-out lines are illustrated in Figure 5-8.*

---

*Editorial Note.— New Figure 5-8:*

---



**Figure 5-8 Helicopter stand designed for hover-turning markings**

*Editorial Note.*— New sub-section on flight path alignment guidance marking

## 5.2.18 Flight path alignment guidance marking

### **Application**

5.2.18.1 **Recommendation.**— *Flight path alignment guidance marking(s) should be provided at a heliport where it is desirable and practicable to indicate available approach and/or take-off flight path direction(s).*

*Note.*— *The flight path alignment guidance marking can be combined with a flight path alignment guidance lighting system described in 5.3.3A.*

### **Location**

5.2.18.2 The flight path alignment guidance marking shall be located in a straight line along the direction of approach and/or take-off flight path on one or more of the TLOF, FATO, FATO/TLOF, safety area or any suitable surface in the immediate vicinity of the FATO or safety area.

### **Characteristics**

5.2.18.3 A flight path alignment guidance marking shall consist of one or more arrows marked on the TLOF, FATO or FATO/TLOF and/or safety area surface as shown in Figure 5-9. The stroke of the arrow(s) shall be 50 cm in width and at least 3 m in length. When combined with a flight path alignment guidance lighting system it shall take the form shown in Figure 5-9 which includes scheme for marking 'heads of the arrows' which are constant regardless of stroke length.

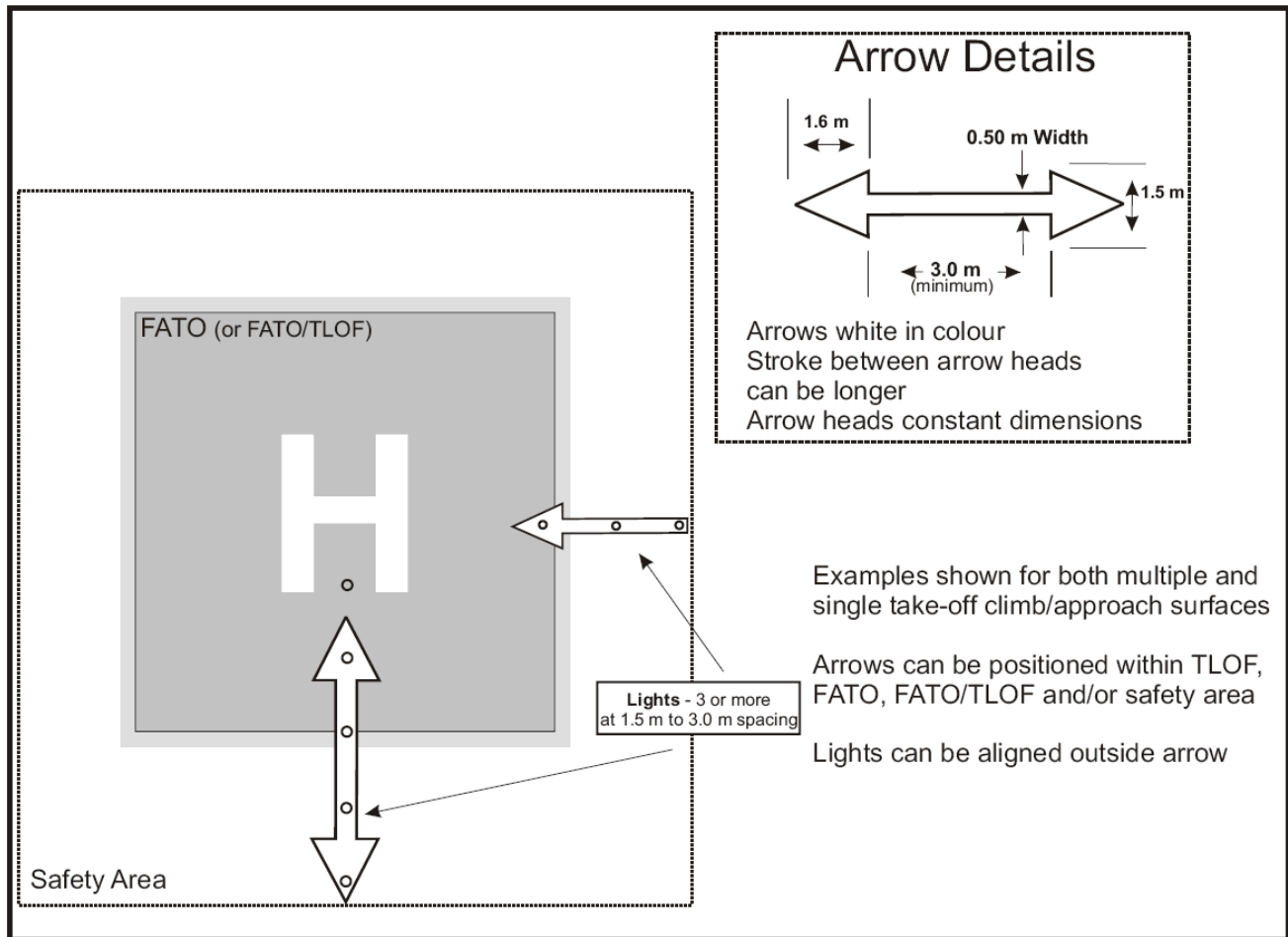
*Note.* — *In the case of a flight path limited to a single approach direction or single take-off direction, the arrow marking may be uni-directional. In the case of a heliport with only a single approach /take-off flight path available, one bi-directional arrow is marked.*

5.2.18.4 **Recommendation.**— *The markings should be in a colour which provides good contrast against the background colour of the surface on which they are marked.*

---

*Editorial Note.*— *New Figure 5-9:*

---



**Figure 5-9 Flight path alignment guidance markings and lights**

*Rationale*

For surface level, elevated heliports, helidecks and shipboard heliports minor editorial changes made to bring the text in line with the introduction in Chapter 3 of a FATO/TLOF designation and separate requirements for "runway-type FATO" and "All FATOs except runway-type FATOs."

Three Notes have been introduced following the main Chapter 5 heading to stress (i) the conspicuity of white and yellow markings can be improved by outlining them in black, (ii) guidance is given in the Heliport Manual to avoid confusion between markings where metric units are used and markings where imperial units are use, and (iii) for non-purpose built heliports located on a ship's side the surface colour of the main deck can vary from ship to ship, meaning some discretion may be needed in the colour selection of the heliport paint schemes.

A complete new sub-section to cover helicopter stand markings, not addressed in the current annex, and for surface level and elevated heliports a new section on flight path alignment guidance marking, to allow marking of the 'flight path' direction(s) with one or more arrows, has been added.

### 5.3 Lights

*Note 4. — The following specifications have been developed for systems intended for use in conjunction with a non-instrument or non-precision FATO.*

*Note 4 — Specifications in sections 5.3.4, 5.3.6, 5.3.7, and 5.3.8 are designed to provide effective lighting systems based on night conditions. Where lights are to be used in conditions other than night (i.e. - day or twilight) it may be necessary to increase the intensity of the lighting to maintain effective visual cues by use of a suitable brilliancy control. Guidance is provided in the Aerodrome Design Manual (Doc 9157), Part 4 Visual Aids, Chapter 5 Light Intensity Settings.*

.....

---

*Editorial Note.— Delete Figure 5-7 from this section [New Figure 5.7 in section 5.2].*

---

...

---

*Editorial Note.— Renumber existing Figure 5-8 as new Figure 5-10, and change reference in text.*

---

.....

---

*Editorial Note.— Figure 5-9: renumber to Figure 5-11 and change title as indicated and change title of Illustration 6 and Note under Illustration 6 to that indicated below. Add white light.*

---

#### **Title - Illustration 6 of Figure 5-9 renumbered to Figure 5-11.**

Illustration 6 - ~~Touchdown and lift-off area~~ TLOF perimeter lights, FATO/TLOF perimeter lights and flight path alignment guidance lighting system

#### **Note and colour addition under Illustration 6.**

(green or white light)

*Note - Additional values may be required in the case of installations requiring identification by means of the lights at an elevation of less than two degrees*

**Amended title for existing Figure 5-9**

**Figure 5-911. Isocandela diagrams of lights meant for  
Helicopter non-instrument and non-precision approaches**

...

---

*Editorial Note.*— Renumber existing Figure 5-10 as Figure 5-12.

---

...

---

*Editorial Note.*— 5.3.3.4 and 5.3.3.6 are deleted here and transferred to Appendix 2. Renumber 5.3.3.5 to 5.3.3.4, 5.3.3.7 to 5.3.3.5, 5.3.3.8 to 5.3.3.6 and 5.3.3.9 to 5.3.3.7.

---

.....

~~5.3.3.4 **Recommendation.**— Where an approach lighting system is provided for a non-precision FATO, the system should not be less than 210 m in length~~

.....

~~5.3.3.6 **Recommendation.**— The light distribution of steady lights should be as indicated in Figure 5-9, Illustration 2 except that the intensity should be increased by a factor of 3 for a non-precision FATO.~~

.....

---

*Editorial Note.*— Insert new Section 5.3.4. Renumber all subsequent subsections: existing 5.3.4 to 5.3.5, etc.

---

**5.3.4 Flight path alignment guidance lighting system**

***Application***

**5.3.4.1 *Recommendation.***— *Flight path alignment guidance lighting system(s) should be provided at a heliport where it is desirable and practicable to indicate available approach and/or take-off flight path direction(s).*

*Note.*— *The flight path alignment guidance lighting can be combined with a flight path alignment guidance marking(s) described in 5.2.18.*

**Location**

5.3.4.2 The flight path alignment guidance lighting system shall be in a straight line along the direction(s) of approach and/or take-off flight path on one or more of the TLOF, FATO, FATO/TLOF safety area or any suitable surface in the immediate vicinity of the FATO, FATO/TLOF or safety area.

5.3.4.3 **Recommendation.**— *If combined with a flight path alignment guidance marking, as far as is practicable the lights should be located inside the ‘arrow’ markings.*

**Characteristics**

5.3.4.4 **Recommendation**—*A flight path alignment guidance lighting system should consist of a row of three or more lights spaced uniformly a total minimum distance of 6 m. Intervals between lights should not be less than 1.5 m and should not exceed 3 m. Where space permits there should be 5 lights. See Figure 5-9.*

Note.— The number of lights and spacing between these lights may be adjusted to reflect the space available. If more than one flight path alignment system is used to indicate available approach and/or take-off flight path direction(s), the characteristics for each system are typically kept the same. See Figure 5-9.

5.3.4.5 The lights shall be steady omnidirectional inset white lights.

5.3.4.6 **Recommendation.** *The distribution of the lights should be as indicated in Figure 5-11, Illustration 6.*

5.3.4.7 **Recommendation.**— *A suitable control should be incorporated to allow for adjustment of light intensity to meet the prevailing conditions and to balance the flight path alignment guidance lighting system with other heliport lights and general lighting that may be present around the heliport*

.....

---

*Editorial Note.*— Again, renumber subsequent subsections: existing 5.3.4 to 5.3.5, etc.

---

...

---

*Editorial Note.*— Renumber existing Figure 5-11 as Figure 5-13.

---

.....

---

*Editorial Note.*— Replace Table 5-1 with new Table 5-1 as follows: information in Table 5-1 related to non-precision FATO transferred to Table A5-1 in Appendix 2.

---

**Table 5-1. Dimensions and slopes of the obstacle protection surface**

<b>SURFACE AND DIMENSIONS</b>	<b>NON-INSTRUMENT FATO</b>		<b>NON-PRECISION FATO</b>
Length of inner edge	Width of safety area		Width of safety area
Distance from end of FATO	3 m minimum		60 m
Divergence	10%		15%
Total length	2 500 m		2 500 m
Slope	PAPI	A <sup>a</sup> - 0.57°	A <sup>a</sup> - 0.57°
	HAPI	A <sup>b</sup> - 0.65°	A <sup>b</sup> - 0.65°
	APAPI	A <sup>a</sup> - 0.9°	A <sup>a</sup> - 0.9°
a.As indicated in Annex 14, Volume I, Figure 5-1219.			
b.The angle of the upper boundary of the “below slope” signal.			

.....

---

*Editorial Note.*— Renumber existing Figure 5-12 as Figure 5-14.

---

...

---

*Editorial Note.*— Renumber existing Figure 5-13 as Figure 5-15.

---

...

5.3.67 Final approach and take-off area lights lighting systems for surface level heliports

.....

5.3.89 Touchdown and lift-off area lighting system

*Note.*- This subsection also applies to a FATO/TLOF lighting system

.....

## APPENDIX 1. AERONAUTICAL DATA QUALITY REQUIREMENTS

**Table A1-1. Latitude and longitude**

Latitude and longitude	Accuracy Data type	Integrity Classification
Heliport reference point .....	30 m surveyed/calculated	$1 \times 10^{-3}$ routine
Nav aids located at the heliport .....	3 m surveyed	$1 \times 10^{-5}$ essential
Obstacles in Area 3 .....	0.5 m surveyed	$1 \times 10^{-5}$ essential
Obstacles in Area 2 (the part within the heliport boundary) .....	5 m surveyed	$1 \times 10^{-5}$ essential
Geometric centre of TLOF or FATO thresholds .....	1 m surveyed	$1 \times 10^{-8}$ critical
Ground taxiway centre line points, <del>and</del> air taxiway <del>and transit route</del> points .....	0.5 m surveyed/calculated	$1 \times 10^{-5}$ essential
Ground taxiway intersection marking line .....	0.5 m surveyed	$1 \times 10^{-5}$ essential
Ground exit guidance line .....	0.5 m surveyed	$1 \times 10^{-5}$ essential
Apron boundaries (polygon) .....	1 m surveyed	$1 \times 10^{-3}$ routine
De-icing/anti-icing facility (polygon) .....	1 m surveyed	$1 \times 10^{-3}$ routine
Helicopter standpoints/INS checkpoints .....	0.5 m surveyed	$1 \times 10^{-3}$ routine

*Note 1.— See Annex 15, Appendix 8, for graphical illustrations of obstacle data collection surfaces and criteria used to identify obstacles in the defined areas.*

*Note 2.— Implementation of Annex 15, provision 10.6.1.2, concerning the availability, as of 18 November 2010, of obstacle data according to Area 2 and Area 3 specifications would be facilitated by appropriate advance planning for the collection and processing of such data.*

**Table A1-2. Elevation/altitude/height**

Elevation/altitude/height	Accuracy Data type	Integrity Classification
Heliport elevation .....	0.5 m surveyed	1 × 10 <sup>-5</sup> essential
WGS-84 geoid undulation at heliport elevation position .....	0.5 m surveyed	1 × 10 <sup>-5</sup> essential
FATO threshold, <del>non-precision approaches</del> For heliports with or without a PinS approach .....	0.5 m surveyed	1 × 10 <sup>-5</sup> essential
WGS-84 geoid undulation at FATO threshold, TLOF geometric centre, <del>non-precision approaches</del> for heliports with or without a PinS approach .....	0.5 m surveyed	1 × 10 <sup>-5</sup> essential
FATO threshold, <del>precision approaches</del> for heliports intended to be operated in accordance with Appendix 2 .....	0.25 m surveyed	1 × 10 <sup>-8</sup> critical
WGS-84 geoid undulation at FATO threshold, TLOF geometric centre, <del>precision approaches</del> for heliports intended to be operated in accordance with Appendix 2 .....	0.25 m surveyed	1 × 10 <sup>-8</sup> critical
Ground taxiway centre line points, <del>and</del> air taxiway <del>and transit route</del> points .....	1 m surveyed	1 × 10 <sup>-5</sup> essential
Obstacles in Area 2 (the part within the heliport boundary) .....	3 m surveyed	1 × 10 <sup>-5</sup> essential
Obstacles in Area 3 .....	0.5 m surveyed	1 × 10 <sup>-5</sup> essential
Distance measuring equipment/precision (DME/P) .....	3 m surveyed	1 × 10 <sup>-5</sup> essential

*Note 1.— See Annex 15, Appendix 8, for graphical illustrations of obstacle data collection surfaces and criteria used to identify obstacles in the defined areas.*

*Note 2.— Implementation of Annex 15, provision 10.6.1.2, concerning the availability, as of 18 November 2010, of obstacle data according to Area 2 and Area 3 specifications would be facilitated by appropriate advance planning for the collection and processing of such data.*

**Table A1-3. Declination and magnetic variation**

Declination/variation	Accuracy Data type	Integrity Classification
Helipoint magnetic variation .....	1 degree surveyed	$1 \times 10^{-5}$ essential
ILS localizer antenna magnetic variation .....	1 degree surveyed	$1 \times 10^{-5}$ essential
MLS azimuth antenna magnetic variation .....	1 degree surveyed	$1 \times 10^{-5}$ essential

**Table A1-4. Bearing**

Bearing	Accuracy Data type	Integrity Classification
ILS localizer alignment .....	1/100 degree surveyed	$1 \times 10^{-5}$ essential
MLS zero azimuth alignment .....	1/100 degree surveyed	$1 \times 10^{-5}$ essential
FATO bearing (true) .....	1/100 degree surveyed	$1 \times 10^{-3}$ routine

**Table A1-5. Length/distance/dimension**

Length/distance/dimension	Accuracy Data type	Integrity Classification
FATO length, TLOF dimensions .....	1 m surveyed	$1 \times 10^{-8}$ critical
Clearway length and width .....	1 m surveyed	$1 \times 10^{-5}$ essential
Landing distance available .....	1 m surveyed	$1 \times 10^{-8}$ critical
Take-off distance available .....	1 m surveyed	$1 \times 10^{-8}$ critical
Rejected take-off distance available .....	1 m surveyed	$1 \times 10^{-8}$ critical
Taxiway/ <u>taxi-route</u> width .....	1 m surveyed	$1 \times 10^{-5}$ essential
ILS localizer antenna-FATO end, distance .....	3 m calculated	$1 \times 10^{-3}$ routine
ILS glide slope antenna-threshold, distance along centre line .....	3 m calculated	$1 \times 10^{-3}$ routine
ILS marker-threshold distance .....	3 m calculated	$1 \times 10^{-5}$ essential
ILS DME antenna-threshold, distance along centre line .....	3 m calculated	$1 \times 10^{-5}$ essential
MLS azimuth antenna-FATO end, distance .....	3 m calculated	$1 \times 10^{-3}$ routine
MLS elevation antenna-threshold, distance along centre line.....	3 m calculated	$1 \times 10^{-3}$ routine
MLS DME/P antenna-threshold, distance along centre line .....	3 m calculated	$1 \times 10^{-5}$ essential

## **APPENDIX 2**

# **INTERNATIONAL STANDARDS AND RECOMMENDED PRACTICES FOR INSTRUMENT HELIPORTS WITH NON-PRECISION AND/OR PRECISION APPROACHES AND INSTRUMENT DEPARTURES**

## **CHAPTER 1. GENERAL**

*Introductory Note.- Annex 14, Volume II, contains Standards and Recommended Practices (specifications) that prescribe the physical characteristics and obstacle limitation surfaces to be provided for at heliports, and certain facilities and technical services normally provided at a heliport. It is not intended that these specifications limit or regulate the operation of an aircraft.*

*Note 1.- The specifications in this appendix describe additional conditions beyond those found in the main sections of Annex 14, Volume II, that apply to instrument heliports with non-precision and/or precision approaches. All specifications contained within the main chapters of Annex 14, Volume II are equally applicable to instrument heliports, but with reference to further provisions described in this Appendix.*

## **CHAPTER 2. HELIPORT DATA**

### **2.3 Heliport Elevation**

2.3.1 The elevation of the TLOF and/or the elevation and geoid undulation of each threshold of the FATO or FATO/TLOF (where appropriate) shall be measured and reported to the aeronautical information services authority to the accuracy of:

- a) one-half metre or foot for non-precision approaches; and
- b) one-quarter metre or foot for precision approaches.

*Note.— Geoid undulation must be measured in accordance with the appropriate system of coordinates.*

### **2.4 Heliport dimensions and related information**

2.4.1 The following additional data shall be measured or described, as appropriate, for each facility provided on an instrument heliport:

- a) distances to the nearest metre or foot of localizer and glide path elements comprising an instrument landing system (ILS) or azimuth and elevation antenna of a microwave landing system (MLS) in relation to the associated TLOF or FATO extremities.

## CHAPTER 3. PHYSICAL CHARACTERISTICS

### 3.1 Surface-level and elevated heliports

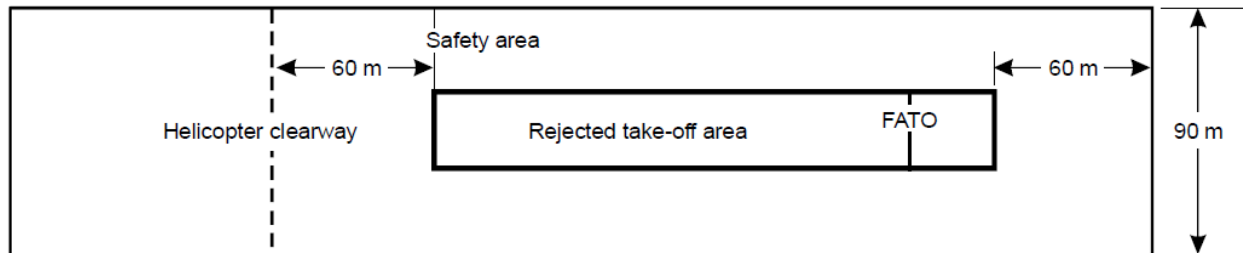
#### Safety Areas

3.1.1 A safety area surrounding an instrument FATO or FATO/TLOF shall extend:

- a) laterally to a distance of at least 45 m on each side of the centre line; and  
 b) longitudinally to a distance of at least 60 m beyond the ends of the FATO.

Note.- See Figure A3-1.

*Editorial Note.*— This is existing Figure 3-1 relocated to Appendix 2.



**Figure A3-1. Safety Area for Instrument FATO**

## CHAPTER 4. OBSTACLE ENVIRONMENT

### 4.1 Obstacle limitation surfaces and sectors

#### Approach surface

4.1.1 *Characteristics.* The limits of an approach surface shall comprise:

- a) an inner edge horizontal and equal in length to the minimum specified width of the FATO plus the safety area, perpendicular to the centre line of the approach surface and located at the outer edge of the safety area;
- b) two side edges originating at the ends of the inner edge;
  - i) for an instrument FATO with a non-precision approach, diverging uniformly at a specified rate from the vertical plane containing the centre line of the FATO
  - ii) for an instrument FATO with a precision approach, diverging uniformly at a specified rate from the vertical plane containing the centre line of the FATO, to a specified height above FATO, and then diverging uniformly at a specified rate to a specified final width and continuing thereafter at that width for the remaining length of the approach surface; and
- c) an outer edge horizontal and perpendicular to the centre line of the approach surface and at a specified height above the elevation of the FATO.

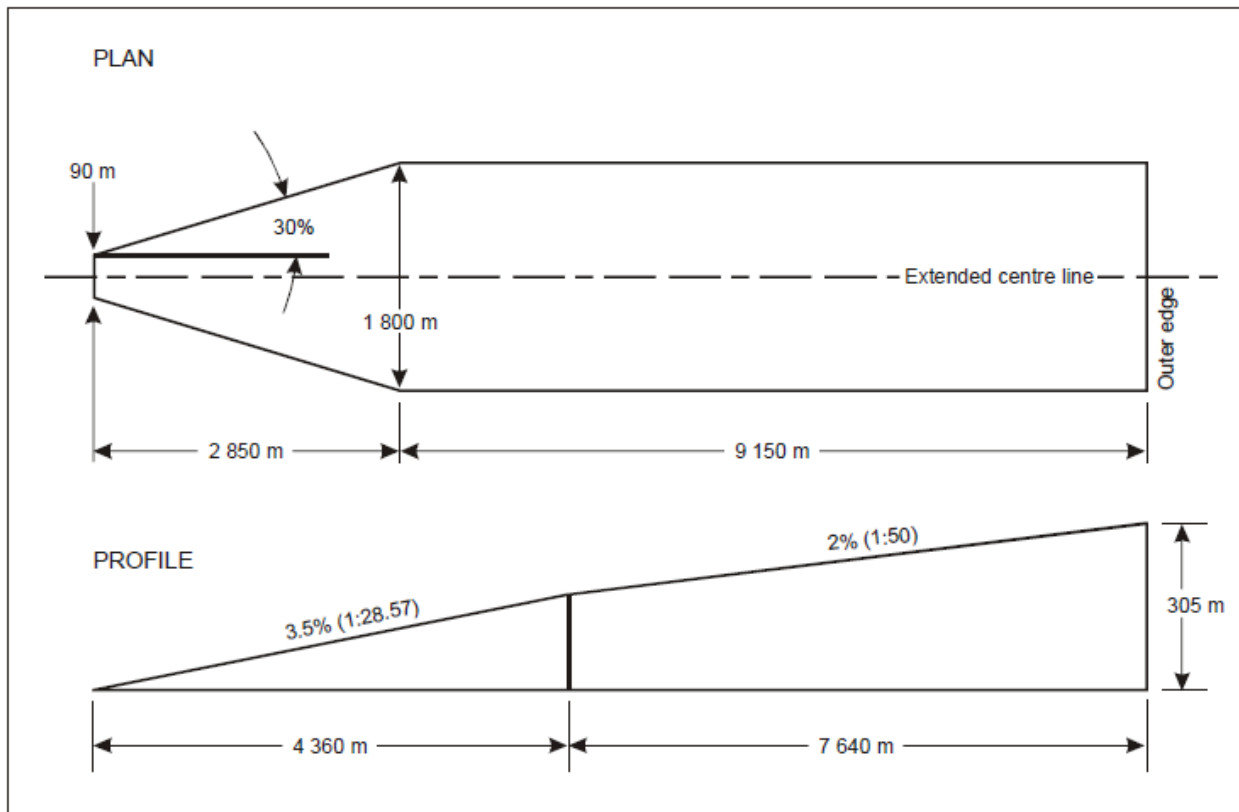
### 4.2 Obstacle Limitation Requirements

4.2.1 The following obstacle limitation surfaces shall be established for an instrument FATO with a non-precision and/or precision approach:

- a) take-off climb surface;
- b) approach surface; and
- c) transitional surfaces.

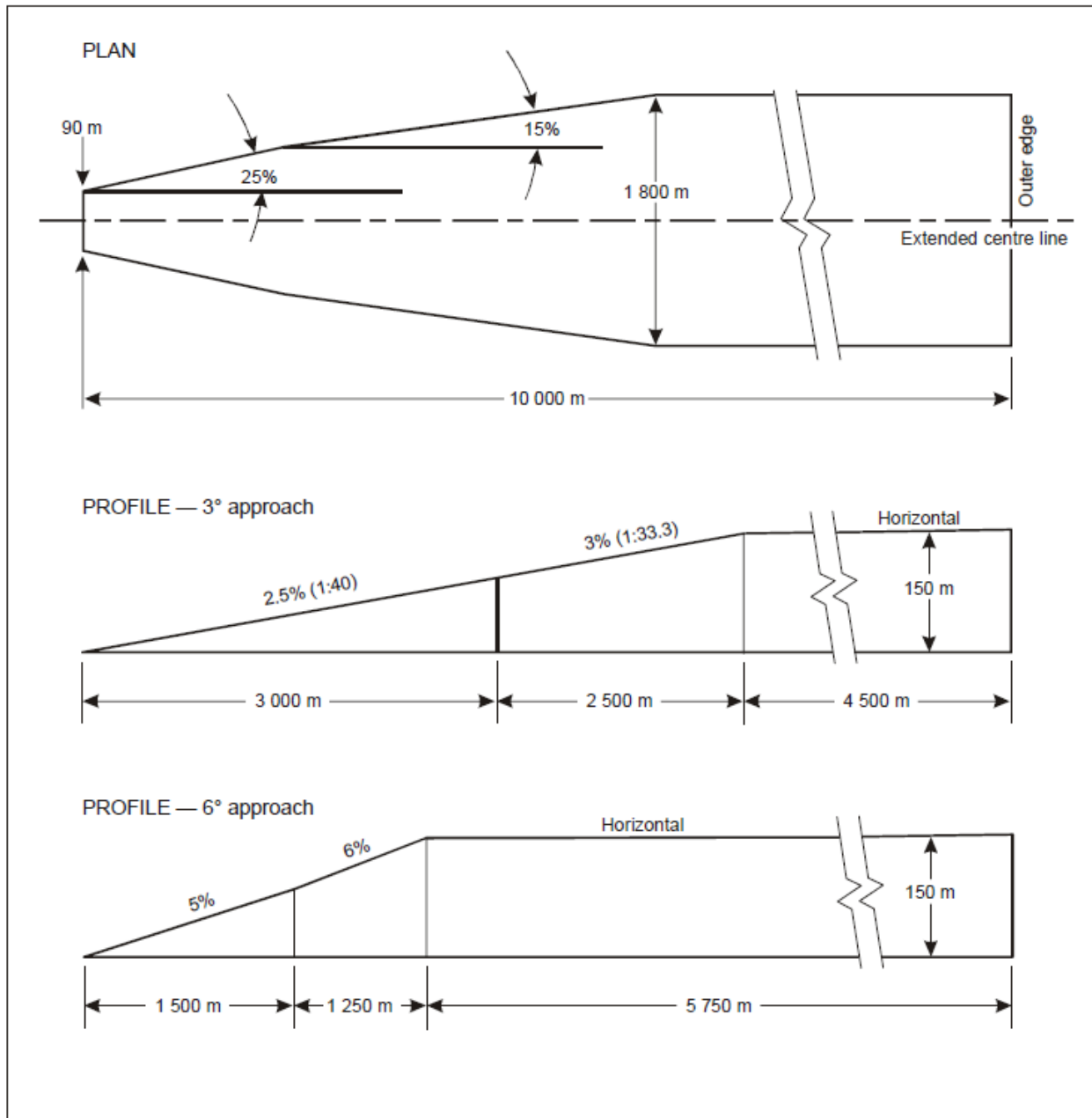
*Note.* - See Figure A4-1 to A4-4

*Editorial Note.*— This is existing Figure 4-5 relocated to Appendix 2.



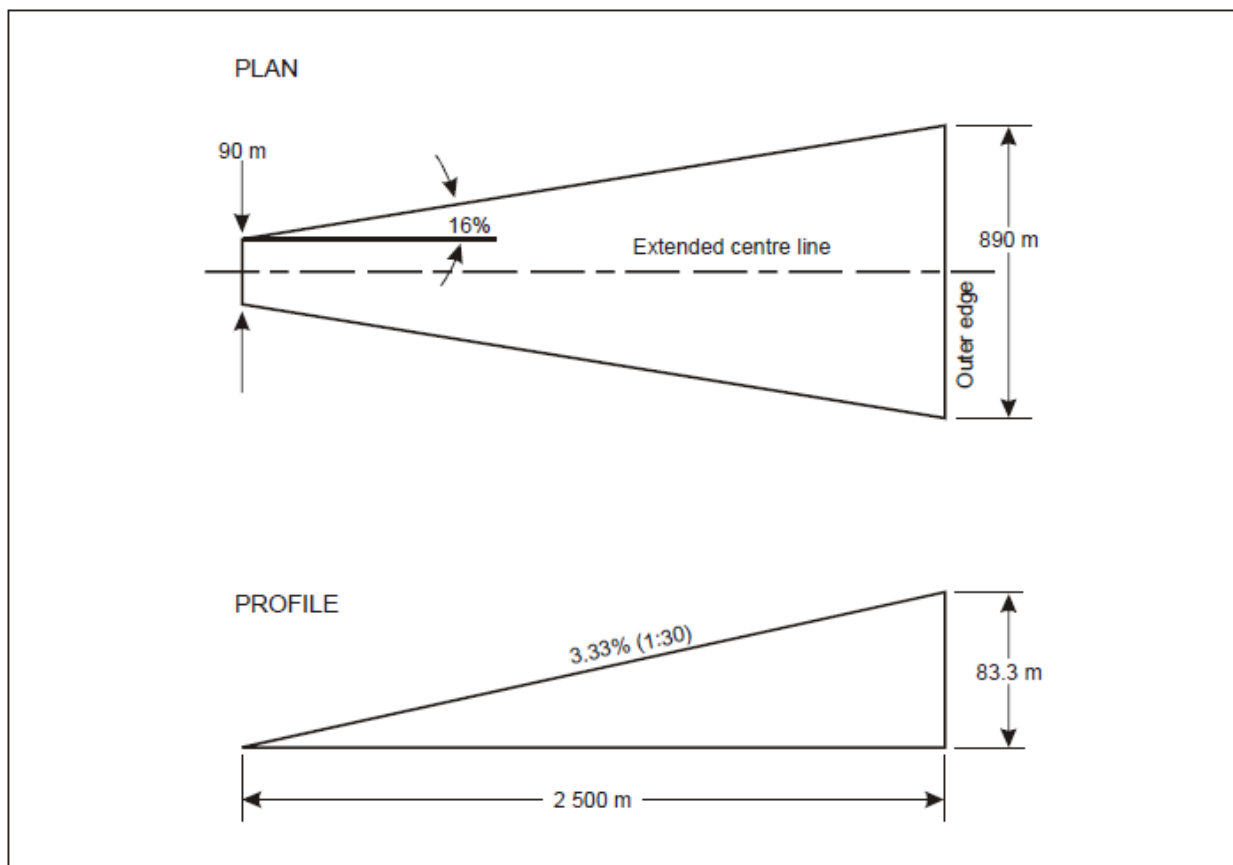
**Figure A4-1. Take-off climb Surface for Instrument FATO**

*Editorial Note.*— This is existing Figure 4-6 relocated to Appendix 2.

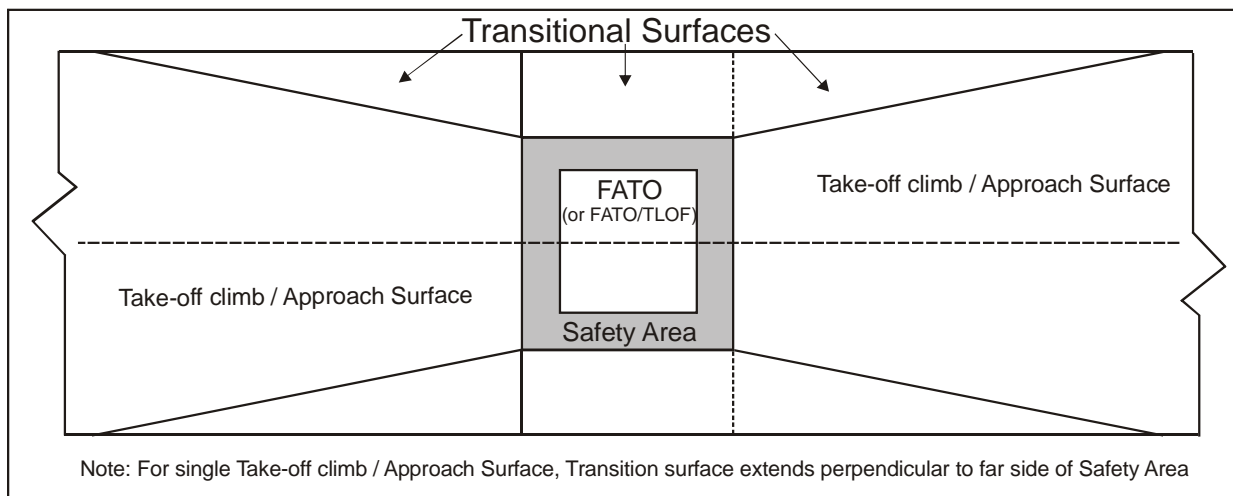


**Figure A4-2. Approach surface for Precision Approach FATO**

*Editorial Note.*— This is existing Figure 4-7 relocated to Appendix 2.



**Figure A4-3. Approach surface for Non-precision Approach FATO**



**Figure A4-4 Transitional Surfaces for an instrument FATO with a non-precision and/or precision approach**

4.2.2 The slopes of the obstacle limitation surfaces shall not be greater than, and their other dimensions not less than, those specified in Tables A4-1 to A4-3.

**Table A4-1. Dimensions and slopes of Obstacle Limitation Surfaces**

**Instrument (Non-precision) FATO**

Surface and dimensions		
APPROACH SURFACE		
Width of inner edge		Width of safety area
Location of inner edge		Boundary
<i>First section</i>		
Divergence	— day	16%
	— night	
Length	— day	2 500 m
	— night	
Outer width	— day	890 m
	— night	
Slope (maximum)		3.33%
<i>Second section</i>		
Divergence	— day	—
	— night	
Length	— day	—
	— night	
Outer width	— day	—
	— night	
Slope (maximum)		—
<i>Third section</i>		
Divergence		—
Length	— day	—
	— night	
Outer width	— day	—
	— night	
Slope (maximum)		—
TRANSITIONAL		
Slope		20%
Height		45 m



**Table A4-3. Dimensions and slopes of Obstacle Limitation Surfaces****STRAIGHT TAKE-OFF**

Surface and dimensions		Instrument
<b>TAKE-OFF CLIMB</b>		
Width of inner edge		90 m
Location of inner edge		Boundary or end of clearway
<i>First section</i>		
Divergence	— day	30%
	— night	
Length	— day	2 850 m
	— night	
Outer width	— day	1 800 m
	— night	
Slope (maximum)		3.5%
<i>Second section</i>		
Divergence	— day	parallel
	— night	
Length	— day	1 510 m
	— night	
Outer width	— day	1 800 m
	— night	
Slope (maximum)		3.5%*
<i>Third section</i>		
Divergence		parallel
Length	— day	7 640 m
	— night	
Outer width	— day	1 800 m
	— night	
Slope (maximum)		2%

\* This slope exceeds the maximum mass one-engine-inoperative climb gradient of many helicopters which are currently operating.

**CHAPTER 5. VISUAL AIDS****5.3 Lights****5.3.3 Approach Lighting Systems**

**5.3.3.1 Recommendation.**— *Where an approach lighting system is provided for a non-precision FATO, the system should not be less than 210 m in length.*

**5.3.3.2 Recommendation.**— *The light distribution of steady lights should be as indicated in Figure 5-11, Illustration 2 except that the intensity should be increased by a factor of 3 for a non-precision FATO.*

**Table A5-1. Dimensions and slopes of the obstacle protection surface**

<b>SURFACE AND DIMENSIONS</b>	<b>NON-PRECISION FATO</b>	
Length of inner edge	Width of safety area	
Distance from end of FATO	60 m	
Divergence	15%	
Total length	2 500 m	
Slope	PAPI	A <sup>a</sup> - 0.57°
	HAPI	A <sup>b</sup> - 0.65°
	APAPI	A <sup>a</sup> - 0.9°
a.As indicated in Annex 14, Volume I, Figure 5-19.		
b.The angle of the upper boundary of the “below slope” signal.		

*Rationale*

Although PinS approaches (with or without a visual segment) are the most common means of instrument approach to a (visual) heliport, there are still some examples of instrument (non-precision or precision) heliports and some states have indicated that future instrument (non-precision or precision) heliports may be built. As a result, non-precision and precision heliport has been retained for future review and revision, however to provide for better flow of the document, this section has been moved to an appendix.

...

-----

ATTACHMENT B to State letter AN 4/1.1.51-11/31

**RESPONSE FORM TO BE COMPLETED AND RETURNED TO ICAO TOGETHER  
WITH ANY COMMENTS YOU MAY HAVE ON THE PROPOSED AMENDMENTS**

To: The Secretary General  
International Civil Aviation Organization  
999 University Street  
Montréal, Quebec  
Canada, H3C 5H7

(State) \_\_\_\_\_

Please make a checkmark (✓) against one option for each amendment. If you choose options “agreement with comments” or “disagreement with comments”, **please provide your comments on separate sheets.**

	<i>Agreement without comments</i>	<i>Agreement with comments*</i>	<i>Disagreement without comments</i>	<i>Disagreement with comments</i>	<i>No position</i>
Amendment to Annex 14, Volume II – <i>Heliports</i> (Attachment A refers)					

\*“Agreement with comments” indicates that your State or organization agrees with the intent and overall thrust of the amendment proposal; the comments themselves may include, as necessary, your reservations concerning certain parts of the proposal and/or offer an alternative proposal in this regard.

Signature: \_\_\_\_\_ Date: \_\_\_\_\_

— END —