



International Civil Aviation Organization

**THE FIFTH MEETING OF AERONAUTICAL
TELECOMMUNICATION NETWORK (ATN)
IMPLEMENTATION CO-ORDINATION GROUP
OF APANPIRG (ATNICG/5)**



Kuala Lumpur, Malaysia, 31 May – 4 June 2010

**Agenda Item 11: Review ATN/AMHS Implementation Related Regional Guidance
Material**

**PROPOSED ENHANCEMENTS TO ANNEX C OF
ASIA/PACIFIC AMHS MANUAL**

(Presented by Singapore on behalf of the ATNICG Task 3 Group)

SUMMARY

This paper presents the proposed enhancements to Annex C of the Asia/Pacific AMHS Manual that were presented by the United States in the Seventh ATNICG WG (ATNICG WG/7) Meeting held in Bangkok on 29 January 2010 for review by the meeting. The enhancements include additional test cases and procedures to ensure sufficient scope for interoperability testing of ATN routers, as well as modification of the NSAP addresses to ensure consistency with Version 3.1 of the IDRP Routing Policy.

1 Introduction

1.1 The enhancement to Annex C of the Asia/Pacific AMHS Manual was initially proposed by the United States at the ATNICG WG/6 meeting in September 2009 and was reviewed through WP/05 at the ATNICG WG/7 meeting in January 2010. The Working Group Meeting agreed that a comprehensive amendment to the document should be developed so as to ensure that the scope of interoperability testing is sufficient to meet the requirements of network complexities.

1.2 This paper serves to review the proposed enhancements which consist of the additional test cases and procedures as well as the proposed modifications that were developed subsequent to the meetings.

2 Additional Test Cases

2.1 The current test cases provided in Annex C of the Asia/Pacific AMHS Manual were identified to be somewhat limited in the scope of verifying routing capabilities of ATN routers in multiple domains. Therefore, it is proposed that the following two additional test cases be included in the document:

- i. Test Case 5
 - a. Three ATN routers in a fully connected test network (“or loop”)
 - b. This test would place all three routers in different domains; and

- ii. Test Case 6
 - a. Four ATN routers in a fully connected test network (“or loop”)
 - b. This test would place all four routers in different domains.

2.2 The inclusion of test case 5 and 6 would be able to verify the following scenarios, under normal operational scenarios as well as during scenarios involving circuit failure:

- i. Expansion of the routers/domains in a test network, to three and then four domains
- ii. Removal and restoration of routers from these expanded networks, and verifications of the following elements:
 - a. Updates to routing tables
 - b. Correct route selection from new routing list
 - c. Successful transmission of re-routed messages
 - d. Verification that routing loops are not present
 - e. Verification of network and IDRP parameters

3 Modification of NSAP Addresses

3.1 It is also proposed that the addressing information in Annex C of the Asia/Pacific AMHS Manual be modified to utilize a common 5-byte NSAP prefix rather than differing prefixes within the region; so as to ensure consistency with Version 3.1 of the Asia/Pacific IDRP Routing Policy.

4 Action by the Meeting

4.1 The meeting is invited to review the attached proposed modifications to Annex C of the Asia/Pacific AMHS Manual and provide comments.

ANNEX C

Test Procedure

for

ATN Router Connection Test

ANNEX C
of
AMHS Manual

Document Control Log

Edition	Date	Comments	Section/pages affected
1.0	11/04/2007	Creation of the document.	all
1.0	September 2007	Document is endorsed by APANPIRG/18	all
2.0	22/09/2008	Editorial updates – change of document version number	all
3.0	September 2009	Editorial updates – change of document version number	all
3.1	2010	Proposed amendments (Draft)	

Table of Contents

1. Introduction	1
2. References	1
3. Test Overview and Scope	2
4. Communication Parameters.....	4
5. Schedule and Test Item Overview	4
6. Test Cases	14
6.1. Test Case 1: Router Connection Establishment and Maintenance.....	15
6.2. Test Case 2 : NPDU Relay.....	19
6.3. Test Case 3: Router End-to-End Tests	30
6.4. Test Case 4: ATN Router Tests (This cover additional tests for subnetwork).....	41
6.5. Test Case 5: ATN Router Network Test	66
6.6. Test Case 6: ATN Router Network Test	82

1. Introduction

- 1.1 This document describes the test procedure for the Ground-Ground (G/G) Aeronautical Telecommunication Network (ATN) router connection.

2. References

- [1] Asia/Pacific Regional ATN G/G Router ICD for ISO/IEC 8202 Sub-Network.
- [2] ASIA/PAC Interface Control Document (ICD) for ATN G/G Router
- [3] Test Plan for AMHS Technical Trial between Hong Kong, China and Japan.
- [4] “Technical Memorandum of Cooperation between Engineering & Systems Division, Civil Aviation Department, Hong Kong China and Operations and Flight Inspection Division, Civil Aviation Bureau, Ministry of Land, Infrastructure and Transport, Japan: AMHS Trials and Service between Japan and Hong Kong, China”, February 2003. (Amended 24 August 2004)

3. Test Overview and Scope

- 3.1 A joint ATN Router Connection Test between AMHSLAND1 and AMHSLAND2 using a 9.6kbps X.25 PSDN (packet-switched data network) circuit.
- 3.2 An ATN Router Connection Test is scheduled to verify the connectivity, interoperability, data relaying/routing and redundancy capabilities (where applicable) of the ATN Ground-Ground routers in AMHSLAND1 and AMHSLAND2.
- 3.3 The ATN Router Connection Test will also confirm that the functions of the AMHSLAND1 and AMHSLAND2 ATN routers were configured in preparation for more than 2 routers tests.
- 3.4 The system configuration for the test is shown in Figure 1. Routers in AMHSLAND1 and AMHSLAND2 are linked by an X.25 virtual circuit (VC) over a leased line connection (e.g.64 kbps).

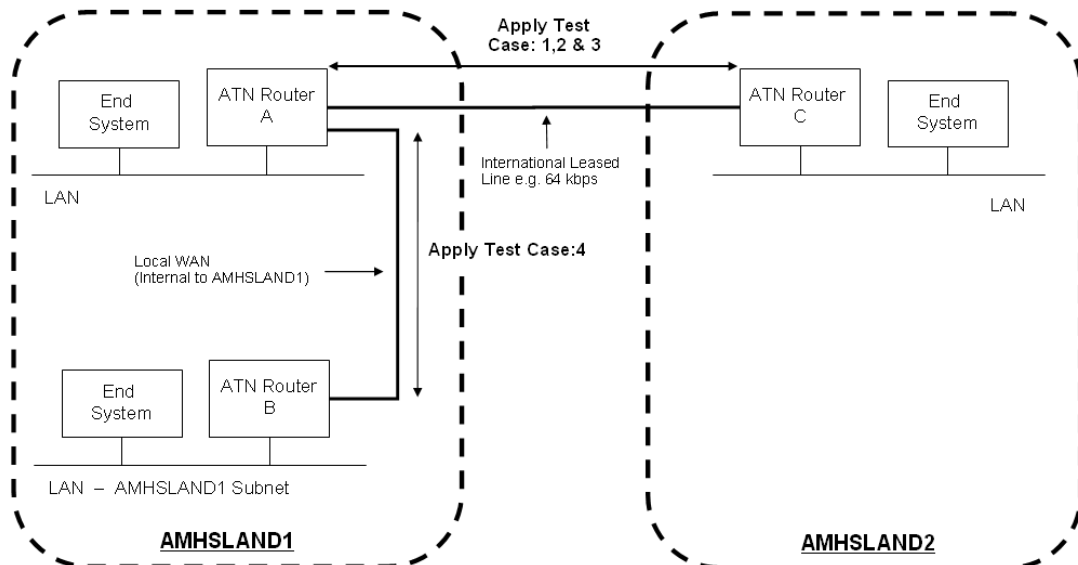

Figure 1 ATN Router Connection Test Configuration

- 3.5 To test data relay and routing functions, CLNP Echo Request (ERQ) Network Protocol Data Units (NPDU) will be generated by the routers and End Systems. To support these tests, all Intermediate Systems shall be capable of generating CLNP ERQ PDUs, and all Intermediate Systems and End Systems shall be capable of transmitting CLNP Echo Response (ERP) PDUs in response to the receipt of ERQ PDUs. Further, it is desirable that End Systems be capable of generating CLNP ERQ PDUs. Execution of some test items is contingent on End Systems' capabilities.
- 3.6 Since both AMHSLAND1 and AMHSLAND2 are ATN backbone sites, the proper updating of their routing tables should be tested in detail. This will ensure that the router could relay the data received from its counterpart to another router either within or outside its own domain/ATN site.
- 3.7 The ATN router network test is to verify the connectivity, interoperability, data relaying/routing and redundancy capabilities (where applicable) of the ATN Ground-Ground routers when expanded to a three and then four domains configuration. The system test configuration is as shown in Figure 2.

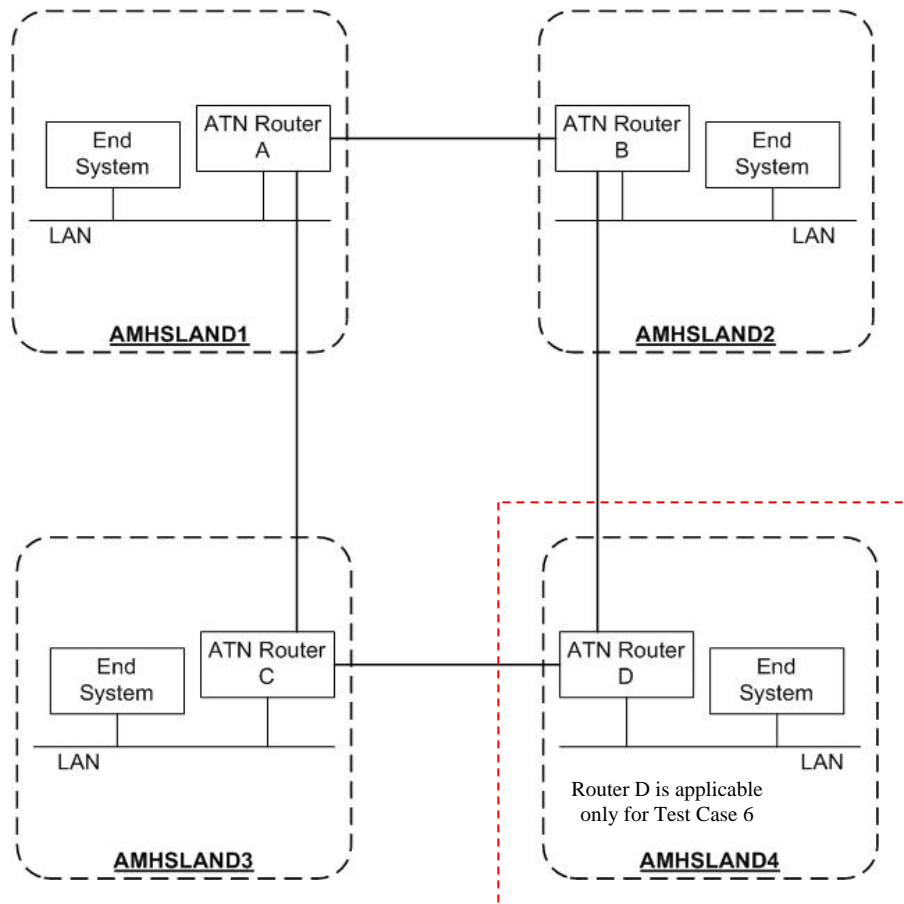

Figure 2 ATN Routers Connection (Multiple Domains) Test Configuration

3.8 A summary of test items for the ATN Router Connection Test is shown in Table 1.

Table 1 Summary of Test Items for ATN Router Connection Test

No.	Test Item	Details
1	Router Connection Establishment and Maintenance	Establish LAPB, X.25 VC and IDRPs connections between routers. Exchange of KEEPALIVE PDUs to maintain IDRPs connection.
2	NPDUs Relay	Tests to confirm CLNP Echo function of routers, correct NPDU relay, and validation of handling of PDUs with invalid security option parameter.
3	Router end-to-end tests	IDRP route addition/deletion, carrier medium failure/restoration and router failure/recovery.
4	ATN router environment tests	Multiple router route addition/deletion, carrier medium failure/restoration and router failure/recovery.
5	ATN router network tests	Multiple router route addition/deletion, carrier medium failure/restoration and router failure/recovery in three-domain configurations. Confirm routing table updates and automatic re-route.
6	ATN router network tests	Multiple router route addition/deletion, carrier medium failure/restoration and router failure/recovery in four-domain configurations. Confirm routing table updates and automatic re-route.

4. Communication Parameters

- 4.1 The proposed communication parameters for the connection between the routers of AMHSLAND1 and AMHSLAND2 for test case 1 to 4 are listed in Table 2.
- 4.2 The proposed CLNP communication parameters for the End Systems are listed in Table 5. It is proposed to use the NSAP addresses of the AMHS systems that will be used in actual operation for the ES NSAP addresses.
- 4.3 The proposed communications parameters for the connection between the routers of AMHSLAND1, AMHSLAND2, AMHSLAND3 and AMHSLAND4 for test case 5 and 6 are listed in Table 6.

5. Schedule and Test Item Overview

- 5.1 The test items and planned schedule are shown in Table 7.

Table 2 Router Communication Parameters

Protocol	Item No.	Item	Parameter		Note
			Router (AMHSLAND1)	Router (AMHSLAND2)	
	1.1	NSAP/NET	ROUTER A: 47.0027.81.91524A.00.010101.0302.000000000000.00 ROUTER B (simulated third domain): 47.0027.81.914b00.00.010101.0302.000000000000.00	ROUTER C: 47.0027.81.915648.00.010101.0202.0202.012A.0100.00	1
CLNP (RPDU)	2.1	Priority	14	14	2
IDRP	3.1	NLRI	ROUTER A: 47.0027.81.91524A.00.010101 ROUTER B: 47.0027.81.914b00.00.010101	ROUTER C: 47.0027.81.915648.00.010101	
	3.2	RDI	ROUTER A: 47.0027.81.91524A.00.010101 ROUTER B: 47.0027.81.914b00.00.010101	ROUTER C: 47.0027.81.915648.00.010101	
	3.3	SecurityRegistrationID	06 04 2B 1B 00 00	06 04 2B 1B 00 00	2
	3.4	Tag Set Name	07 (ATSC Class Security Tag Set)	07 (ATSC Class Security Tag Set)	2
	3.5	ATSC Class	Class C	Class C	2
	3.6	Holding Time	180 sec	180 sec	2
	3.7	KEEPALIVE Send Timer	60 sec	60 sec	2, 3
	3.8	OPEN PDU Transmission	ROUTER A: AMHSLAND1-AMHSLAND2 : OPEN-PDU send ROUTER A: local circuit: OPEN-PDU send ROUTER B: OPEN-PDU receive	ROUTER C: AMHSLAND2 -AMHSLAND1: OPEN-PDU receive ROUTER C: local circuit: OPEN-PDU send	

Note 1: Compliant with Asia/Pacific ATN addressing plan.

Note 2: For all routers used in tests.

Note 3: The value of the KEEPALIVE send timer is the holding timer value divided by 3.

Table 3 Router Communication Parameters (continued)

Protocol	Item No.	Item	Parameter		Note
			Router (AMHSLAND1)	Router (AMHSLAND2)	
X.25	4.1	DTE Address	ROUTER A AMHSLAND1-AMHSLAND2 : 44442000023903 ROUTER A local circuit: 44442000023903 ROUTER B local circuit: 44440110110202	ROUTER C AMHSLAND1-AMHSLAND2 : 48404701021800 ROUTER C local circuit: local matter	
	4.2	LCGN	0	0	4
	4.3	LCN	10	10	4
	4.4	Packet Size	1024	1024	4
	4.5	Window Size	7	7	4
	4.6	Window Size Negotiation	Yes	Yes	4
	4.7	CR Packet Transmission	ROUTER A AMHSLAND1-AMHSLAND2 : Caller (CR send) ROUTER A local circuit: Caller (CR send) ROUTER B local circuit: Called (CR receive)	ROUTER C AMHSLAND1-AMHSLAND2 : Called (CR receive) ROUTER C local circuit: Caller (CR send)	
	4.8	Use of SQ	Yes	Yes	4
	4.9	Packet Sequence	Modulo 8	Modulo 8	4
	4.10	Packet Negotiation	Yes	Yes	4
	4.11	D Bit	OFF	OFF	4
	4.12	M Bit	Yes	Yes	4
	4.13	Restart Request Retransmission Count (R20)	1	1	4
	4.14	Reset Request Retransmission (R22)	1	1	4
	4.15	Clear Request Retransmission Count (R23)	1	1	4
	4.16	Restart Request Timer (T20)	180 sec	180 sec	4
	4.17	DTE Call Request timer (T21)	200 sec	200 sec	4
	4.18	Reset Confirmation Timer (T22)	180 sec	180 sec	4
	4.19	DTE Clear Confirmation Timer (T23)	180 sec	180 sec	4

Note 4: For AMHSLAND1-AMHSLAND2 circuit. Parameters for local circuits used in more than 2 routers tests are a local matter.

Table 4 Router Communication Parameter (continued)

Protocol	Item No.	Item	Parameter		Note
			Router (AMHSLAND1)	Router (AMHSLAND2)	
LAPB	5.1	Address	ROUTER A AMHSLAND1-AMHSLAND2 : 03 ROUTER A local circuit: 03 ROUTER B local circuit: 01	ROUTER C AMHSLAND1-AMHSLAND2 : 01 ROUTER C local circuit: local matter	
	5.2	Max Outstanding Number	7	7	5
	5.3	Idle Channel State Timer (T3)	60 sec	60 sec	5, 6
	5.4	ACK Receipt Timer (T1)	3 sec	3 sec	5, 7
	5.5	Frame Retransmission Count	5	5	5
	5.6	Maximum Number of bits in I-Frame (N1)	8248	8248	5, 8
	5.7	Frame Sequence	Modulo 8	Modulo 8	5
Physical	6.1	Interface	X.21/V.11 (Line Speed: 64 kbps)	V.11 (Line Speed: 64 kbps)	5
	6.2	Clock	Local Matter	Local Matter	5

Note 5: For AMHSLAND1-AMHSLAND2 circuit. Parameters for local circuits used in more than 2 routers tests are a local matter.

Note 6: APAC ROUTER ICD (ref. [1]) specifies router A: 18–60 seconds, router B: 12–60 seconds.

Note 7: APAC ROUTER ICD (ref. [1]) specifies 6 sec, based on 9,600bps line speed and 256 byte packets.

Note 8: Value depends on the max. X.25 packet size. $N1 = \text{packet header size (3)} + \text{packet size (bytes)} + \text{LAPB address part (1)} + \text{LAPB control part (1)} + \text{LAPB FCS part (2)}$ in BITS. So if the packet size is 1024 bytes, then $N1$ is $(3 + 1024 + 1 + 1 + 2) * 8 = 8248$ bits.

Table 5 End System CLNP Communication Parameters

Protocol	Item No.	Item	Parameter	
			Router (AMHSLAND1)	Router (AMHSLAND2)
	7.1	NSAP	AMHSLAND1 ES: 470027.81.91524A.00.010101.0302.128001091001.01 Third domain ES: 470027.81.914b00.00.010101.0302.000000010051.01	AMHSLAND2 ES: 47.0027.81.915648.00.010101.0202.0202.8002.0100.01
CLNP	7.1	Traffic Type	1 (ATSC/No Traffic Type Policy Preference)	1 (ATSC/No Traffic Type Policy Preference)
	7.2	Security Class	1 (Unclassified)	1 (Unclassified)
	7.3	Priority	8	8
	7.4	Partial Route Recording	No	No

Table 6 Router Communication Parameters (continued)

Protocol	Item No.	Item	Parameter		Note
			Router (AMHSLAND1 & AMHSLAND3)	Router (AMHSLAND2 & AMHSLAND4)	
	8.1	NSAP/NET	ROUTER A (AMHSLAND1): 47.0027.81.91524A.00.010101.0302.000000000000.00 ROUTER C (AMHSLAND3): 47.0027.81.915654.00.010101.0302.000000000000.00	ROUTER B (AMHSLAND2): 47.0027.81.915648.00.010101.0202.0202.012A.0100.00 ROUTER D (AMHSLAND4): 47.0027.81.915753.00.010101.0202.0202.012A.0100.00	1
CLNP (RPDU)	9.1	Priority	14	14	2
IDRP	10.1	NLRI	ROUTER A: 47.0027.81.91524A.00.010101 ROUTER C: 47.0027.81.915654.00.010101	ROUTER B: 47.0027.81.915648.00.010101 ROUTER D: 47.0027.81.915753.00.010101	
	10.2	RDI	ROUTER A: 47.0027.81.91524A.00.010101 ROUTER C: 47.0027.81.915654.00.010101	ROUTER B: 47.0027.81.915648.00.010101 ROUTER D: 47.0027.81.915753.00.010101	
	10.3	SecurityRegistrationID	06 04 2B 1B 00 00	06 04 2B 1B 00 00	2
	10.4	Tag Set Name	07 (ATSC Class Security Tag Set)	07 (ATSC Class Security Tag Set)	2
	10.5	ATSC Class	Class C	Class C	2
	10.6	Holding Time	180 sec	180 sec	2
	10.7	KEEPALIVE Send Timer	60 sec	60 sec	2, 3
	11.1	NSAP	AMHSLAND1 ES: 470027.81.91524A.00.010101.0302.128001091001.01 AMHSLAND3 ES: 470027.81.915654.00.010102.0302.000000010051.01	AMHSLAND2 ES: 47.0027.81.915648.00.010101.0202.0202.8002.0100.01 AMHSLAND4 ES: 47.0027.81.915753.00.010101.0202.0202.8002.0100.01	

Note 1: Compliant with Asia/Pacific ATN addressing plan.

Note 2: For all routers used in tests.

Note 3: The value of the KEEPALIVE send timer is the holding timer value divided by 3.

Table 7 Test Items and Schedule

Schedule (UTC)		Test Item No.		Description
Day	Time			
		1		Router Connection Establishment and Maintenance
			1 ~ 2	Data link establishment
			1 ~ 4	X.25 VC establishment
			1 ~ 2	IDRP connection establishment
			1 ~ 2	Exchange of routing information (UPDATE PDU transmission)
			1 ~ 2	Maintenance of IDRP connection (KEEPALIVE PDU transmission)
		2		NPDU Relay
			1 ~ 3	ERQ/ERP NPDU transmission /reply from AMHSLAND1 router to AMHSLAND2 router
			1 ~ 3	ERQ/ERP NPDU transmission /reply from AMHSLAND2 router to AMHSLAND1 router
			1 ~ 3	ERQ/ERP NPDU transmission/reply from AMHSLAND1 ES to valid destination in AMHSLAND2 domain
			1 ~ 3	ERQ/ERP NPDU transmission from AMHSLAND2 ES to valid destination in AMHSLAND1 domain (Subject to AMHSLAND2 ES ERQ NDU transmission capability.)
			1 ~ 2	ERQ NPDU transmission from AMHSLAND1 ES to unreachable ES in AMHSLAND2 domain
			1 ~ 2	ERQ NPDU transmission from AMHSLAND2 ES to unreachable ES in AMHSLAND1 domain (Subject to AMHSLAND2 ES ERQ NDU transmission capability.)
			1 ~ 2	Routing process in AMHSLAND1 router for NPDU with invalid security option parameter
			1 ~ 2	Routing process in AMHSLAND2 router for NPDU with invalid security option parameter (Subject to AMHSLAND2 ES ERQ NDU transmission capability.)
		3		Router end-to-end tests
			1 ~ 5	Manual router disconnection at AMHSLAND1 router and route deletion
			1	Route activation from AMHSLAND1 router
			1 ~ 5	Manual router disconnection at AMHSLAND2 router and route deletion
			1	Route activation from AMHSLAND2 router
			1 ~ 3	Carrier medium failure and route deletion at AMHSLAND1 router
			1	Carrier medium restoration and route addition at AMHSLAND1 router

Schedule (UTC)		Test Item No.		Description
Day	Time			
		7	1 ~ 3	Carrier medium failure and route deletion at AMHSLAND2 router
		8	1	Carrier medium restoration and route addition at AMHSLAND2 router
		9	1 ~ 2	Failure and recovery of AMHSLAND1 router (redundant configuration)
		10	1 ~ 2	Failure and recovery of AMHSLAND2 router
		4		ATN Router Tests: Third Domain connected to AMHSLAND1
		1	1 ~ 5	Router connection of ROUTER B to ROUTER A (ROUTER A-ROUTER C connection already established)
		2	1 ~ 5	Manual router disconnection at ROUTER A of ROUTER A-ROUTER B route
		3	1 ~ 4	Re-activation at ROUTER A of ROUTER A-ROUTER B route
		4	1 ~ 5	Manual router disconnection at ROUTER B of ROUTER A-ROUTER B route
		5	1 ~ 4	Re-activation at ROUTER B of ROUTER A-ROUTER B route
		6	1 ~ 5	Router connection of ROUTER C to ROUTER A (ROUTER A-ROUTER B connection already established)
		7	1 ~ 5	Manual router disconnection at ROUTER C of ROUTER C-ROUTER A route
		8	1 ~ 4	Re-activation at ROUTER C of ROUTER C-ROUTER A route
		9	1 ~ 5	Manual router disconnection at ROUTER A of ROUTER C-ROUTER A route
		10	1 ~ 4	Re-activation at ROUTER A of ROUTER C-ROUTER A route
		11	1 ~ 3	Carrier medium failure of ROUTER A-ROUTER B circuit
		12	1 ~ 4	Carrier medium recovery of ROUTER A-ROUTER B circuit
		13	1 ~ 3	Carrier medium failure of ROUTER C-ROUTER A circuit
		14	1 ~ 4	Carrier medium recovery of ROUTER C-ROUTER A circuit
		15	1 ~ 2	Failure and recovery of ROUTER C
		16	1 ~ 2	Failure and recovery of ROUTER A
		17	1 ~ 2	Failure and recovery of ROUTER B
		18	1 ~ 6	End-to-End CLNP Echo Test between end systems in ROUTER C and ROUTER B domains (Subject to AMHSLAND2 ES ERQ NDU transmission capability.)

Schedule (UTC)		Test Item No.		Description
Day	Time			
		5		ATN Router Network Test: Three Domain Configuration
			1 ~ 4	Router Connection of ROUTER A to ROUTER B (ROUTER A – ROUTER C and ROUTER B – ROUTER C established)
			1 ~ 3	CLNP echo test between routers
			1 ~ 6	Manual router disconnection at ROUTER A of ROUTER A – ROUTER B route
			1 ~ 3	Router re-activation from ROUTER A
			1 ~ 6	ROUTER B – ROUTER C route
			1 ~ 3	Route re-activation from ROUTER B
			1 ~ 6	Manual router disconnection at ROUTER C of ROUTER C – ROUTER A route
			1 ~ 3	Route re-activation from ROUTER C
			1 ~ 4	Carrier media failure of ROUTER A – ROUTER B circuit and route deletion
			1 ~ 3	Carrier media restoration of ROUTER A – ROUTER B circuit and router addition
			1 ~ 4	Carrier media failure of ROUTER B – ROUTER C circuit and route deletion
			1 ~ 3	Carrier media restoration of ROUTER B – ROUTER C circuit and router addition
			1 ~ 4	Carrier media failure of ROUTER C – ROUTER A circuit and route deletion
			1 ~ 3	Carrier media restoration of ROUTER C – ROUTER A circuit and router addition
			1 ~ 2	Failure and recovery of ROUTER A
			1 ~ 2	Failure and recovery of ROUTER B
			1 ~ 2	Failure and recovery of ROUTER C
			1 ~ 3	CLNP echo test between routers

Schedule (UTC)		Test Item No.	Description
Day	Time		
		6	ATN Router Network Test: Four Domain Configuration
		1	1 ~ 6 Router Connection of ROUTER A to ROUTER B (ROUTER A – ROUTER C and ROUTER B – ROUTER D established)
		2	1 ~ 3 Router connection of ROUTER C to ROUTER D
		3	1 ~ 4 CLNP echo test between routers
		4	1 ~ 4 Manual router disconnection at ROUTER A of ROUTER A – ROUTER B route
		5	1 ~ 3 Route re-activation from ROUTER A
		6	1 ~ 4 Manual router disconnection at ROUTER B of ROUTER B – ROUTER D route
		7	1 ~ 3 Route re-activation from ROUTER B
		8	1 ~ 4 Manual router disconnection at ROUTER D of ROUTER D – ROUTER C route
		9	1 ~ 3 Route re-activation from ROUTER D
		10	1 ~ 4 Manual router disconnection at ROUTER C of ROUTER C – ROUTER A route
		11	1 ~ 3 Route re-activation from ROUTER C
		12	1 ~ 4 Carrier media failure of ROUTER A – ROUTER B circuit
		13	1 ~ 3 Carrier media restoration of ROUTER A – ROUTER B circuit and router addition
		14	1 ~ 4 Carrier media failure of ROUTER B – ROUTER D circuit
		15	1 ~ 3 Carrier media restoration of ROUTER B – ROUTER D circuit and router addition
		16	1 ~ 4 Carrier media failure of ROUTER D – ROUTER C circuit
		17	1 ~ 3 Carrier media restoration of ROUTER D – ROUTER C circuit and router addition
		18	1 ~ 4 Carrier media failure of ROUTER C – ROUTER A circuit
		19	1 ~ 3 Carrier media restoration of ROUTER C – ROUTER A circuit and router addition
		20	1 ~ 2 Failure and recovery of ROUTER A
		21	1 ~ 2 Failure and recovery of ROUTER B
		22	1 ~ 2 Failure and recovery of ROUTER C
		23	1 ~ 2 Failure and recovery of ROUTER D
		24	1 ~ 3 CLNP echo test between routers

6. Test Cases

The table below shows the protocol abbreviations used in sequence diagrams.

Table 8 Protocol Abbreviations

Abbreviation	Protocol	Name
SABM	LAPB	Set Asynchronous Balanced Mode
UA	LAPB	Acknowledgement frame
SQ	X.25	Restart Request
SI	X.25	Restart Indication
SF	X.25	Restart Confirmation
CR	X.25	Call Request
CC	X.25	Call Connected
CQ	X.25	Clear Request
CF	X.25	Clear Confirmation
OPEN PDU	IDRP	OPEN Protocol Data Unit
UPDATE PDU	IDRP	UPDATE Protocol Data Unit
KEEPALIVE PDU	IDRP	KEEPALIVE Protocol Data Unit
CEASE PDU	IDRP	CEASE Protocol Data Unit
ERQ NPDU	CLNP	Echo request Network PDU
ERP NPDU	CLNP	Echo response Network PDU
ER NPDU	CLNP	Error report Network PDU

6.1. Test Case 1: Router Connection Establishment and Maintenance

a) Objective

This test is to verify the establishment of LAPB data link, X.25 Virtual Circuit and IDRP connections between the AMHSLAND2 and AMHSLAND1 routers, the exchange of routing information by UPDATE PDUs, and the maintenance of the IDRP connection by the periodic exchange of KEEPALIVE PDUs. The test configuration is shown in Figure 3.

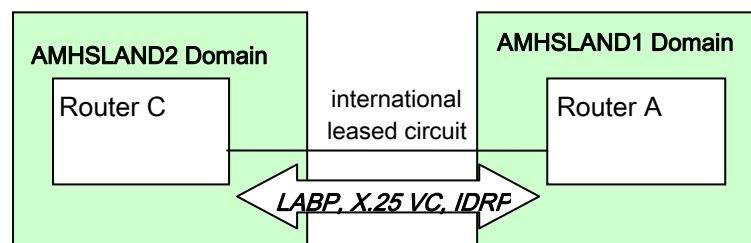

Figure 3 Configuration for router Connection & Maintenance Test

b) Test Items

- 1-1: Data link (LAPB) establishment
- 1-2: X.25 Virtual Circuit establishment
- 1-3: IDRP connection establishment (exchange of OPEN PDUs)
- 1-4: Exchange of routing information (exchange of UPDATE PDUs)
- 1-5: Maintenance of IDRP connection (exchange of KEEPALIVE PDUs)

Table 9 Router Connection Establishment & Maintenance Test Procedure

1. Router Connection Establishment & Maintenance		Test Item	Procedure	Result	Date/Time
Data link establishment	SABM transmission	1-1-1	Send SABM frame (address: 01) from ROUTER A and confirm ROUTER C receives it.	OK / NG	/ /
	UA transmission	1-1-2	Send UA frame (address: 03) from ROUTER C and confirm ROUTER A receives it and data link is established.	OK / NG	/ /
VC establishment	SQ transmission	1-2-1	Confirm ROUTER A sends SQ packet and ROUTER C receives it. (ROUTER C may send SQ packet, depending on the situation.)	OK / NG	/ /
	SI transmission	1-2-2	After receiving SQ packet from ROUTER A, confirm ROUTER C sends SI packet and ROUTER A receives it. (ROUTER C may send SQ packet, depending on the situation.)	OK / NG	/ /
	CR transmission	1-2-3	Confirm ROUTER A sends CR packet (packet size: 1024, LCGN: 0, LCN: 10, calling DTE address: ROUTER A DTE address, called DTE address: ROUTER C DTE address). Confirm ROUTER C receives it.	OK / NG	/ /
	CC transmission	1-2-4	Confirm ROUTER C sends CC packet (packet size: 1024, LCGN: 0, LCN: 10, calling DTE address: ROUTER A DTE address, called DTE address: ROUTER C DTE address). Confirm ROUTER A receives it, and VC is established.	OK / NG	/ /
IDRP connection establishment	OPEN PDU transmission from ROUTER A	1-3-1	After VC establishment, confirm ROUTER A sends an OPEN PDU. Confirm ROUTER C receives it.	OK / NG	/ /
	OPEN PDU transmission from ROUTER C	1-3-2	After receiving OPEN PDU from ROUTER A, confirm ROUTER C sends an OPEN PDU. Confirm that ROUTER A receives it, and IDRP connection is established.	OK / NG	/ /

1. Router Connection Establishment & Maintenance		Test Item	Procedure	Result	Date/Time
UPDATE PDU transmission	UPDATE PDU transmission from ROUTER A	1-4-1	After IDRIP connection established, confirm ROUTER A sends an UPDATE PDU (security registration ID: 06042B1B0000, tag set name: 07, ATSC Class: ATSC Class C, holding timer: 180 sec) to ROUTER C. At ROUTER C, confirm UPDATE PDU is received, and routing information for ROUTER A is added.	OK / NG	/ /
	UPDATE PDU transmission from ROUTER C	1-4-2	After IDRIP connection established, confirm ROUTER C sends an UPDATE PDU (security registration ID: 06042B1B0000, tag set name: 07, ATSC Class: ATSC Class C, holding timer: 180 sec) to ROUTER A. At ROUTER A, confirm UPDATE PDU is received, and routing information for ROUTER C is added.	OK / NG	/ /
IDRIP connection maintenance	KEEPALIVE PDU transmission from ROUTER A	1-5-1	After IDRIP connection established, confirm ROUTER A sends a KEEPALIVE PDU to ROUTER C every 60 seconds. At ROUTER C, confirm routing information received from ROUTER A is not deleted by receiving KEEPALIVE PDU continuously.	OK / NG	/ /
	KEEPALIVE PDU transmission from ROUTER C	1-5-2	After IDRIP connection established, confirm ROUTER C sends a KEEPALIVE PDU to ROUTER A every 60 seconds. At ROUTER A, confirm routing information received from ROUTER C is not deleted by receiving KEEPALIVE PDU continuously.	OK / NG	/ /

6.2. Test Case 2 : NPDU Relay

a) Overview

This test uses the CLNP Echo function to test correct relay and routing of CLNP NPDU's by the AMHSLAND2 and AMHSLAND1 routers. End Systems in both domains are used to verify end-to-end transmission of CLNP PDUs via the routers. The test configuration is shown in Figure 5. The test verifies the following:

- (i) CLNP Echo Request/Echo Response function of both routers.
- (ii) Relay of CLNP NPDU's by routers to the peer domain.
- (iii) ER-PDU returned by peer router when sending a CLNP NPDU to an unknown address in the peer domain.
- (iv) Non-relay of CLNP PDUs with incorrect security parameter by own domain router.

Figure 5 NPDU Transmission and Relay Test Configuration

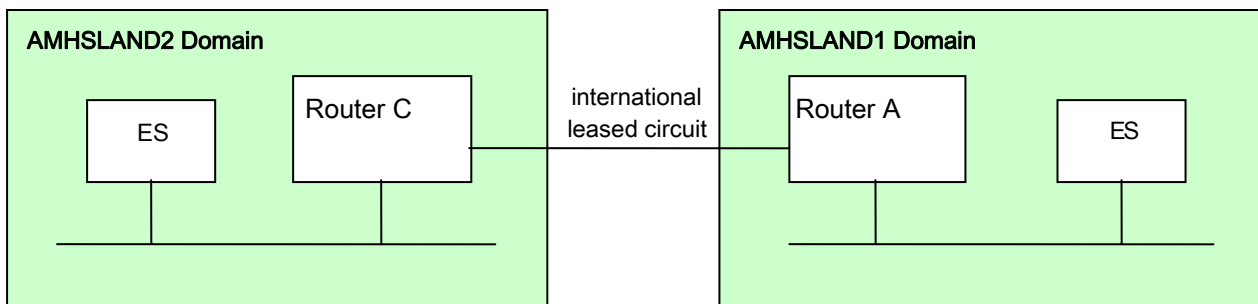

b) Test Items

Note: Some of these test items may not be carried out, depending on the capability of End Systems in each domain in to transmit ERQ-PDUs.

- 2-1: CLNP Echo from AMHSLAND1 router to AMHSLAND2 router.

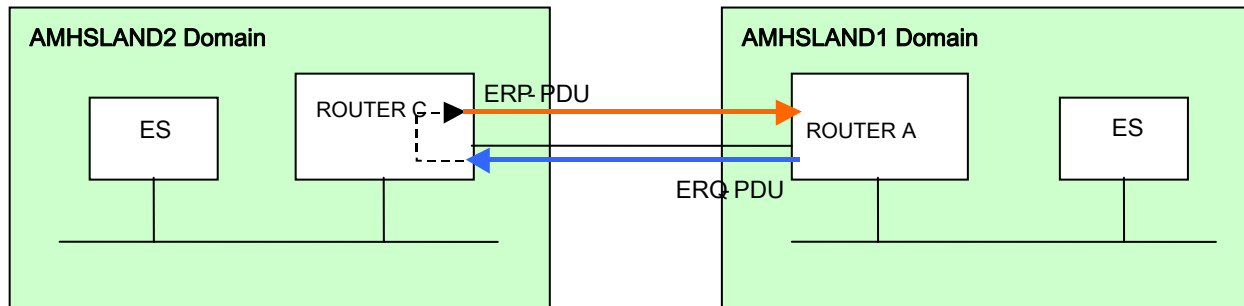

- 2-2: CLNP Echo from AMHSLAND2 router to AMHSLAND1 router.

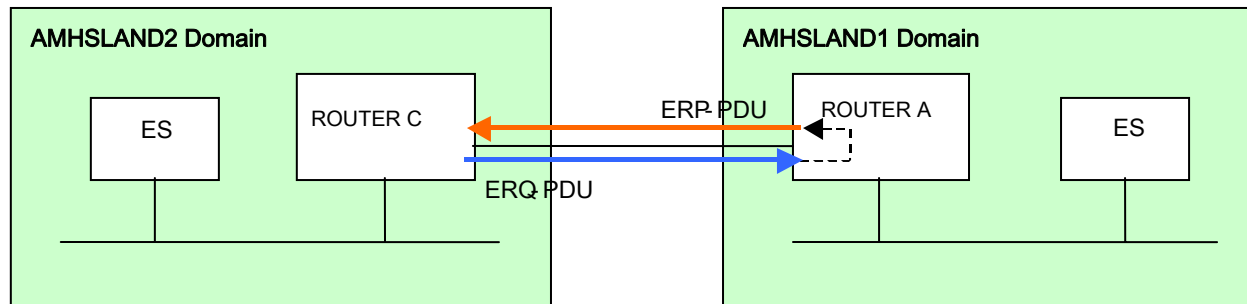

- 2-3: CLNP Echo from AMHSLAND1 End System to valid destination at AMHSLAND2.

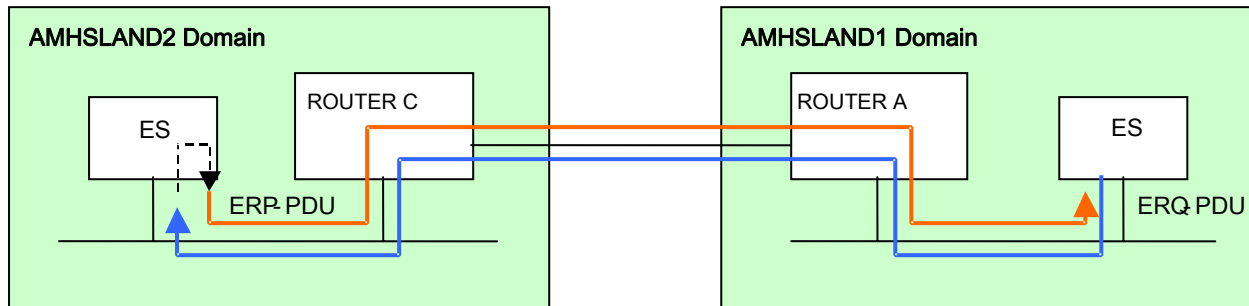

- 2-4: CLNP Echo from AMHSLAND2 End System to valid destination at AMHSLAND1.

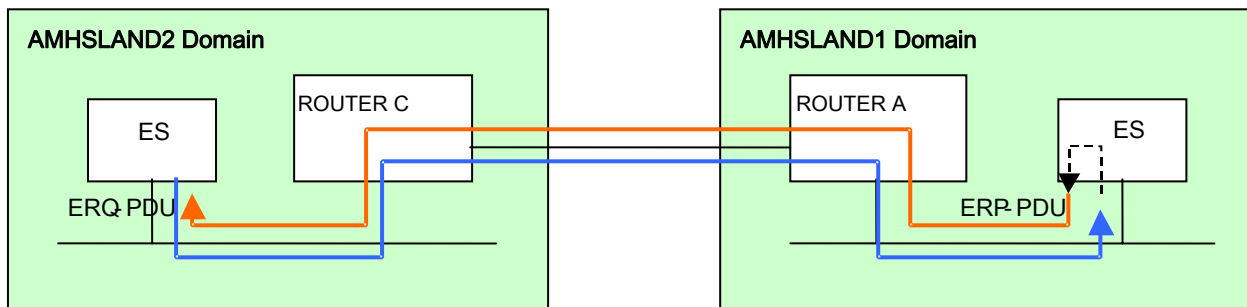

- 2-5: CLNP Echo from AMHSLAND1 End System to unreachable AMHSLAND2 End System.

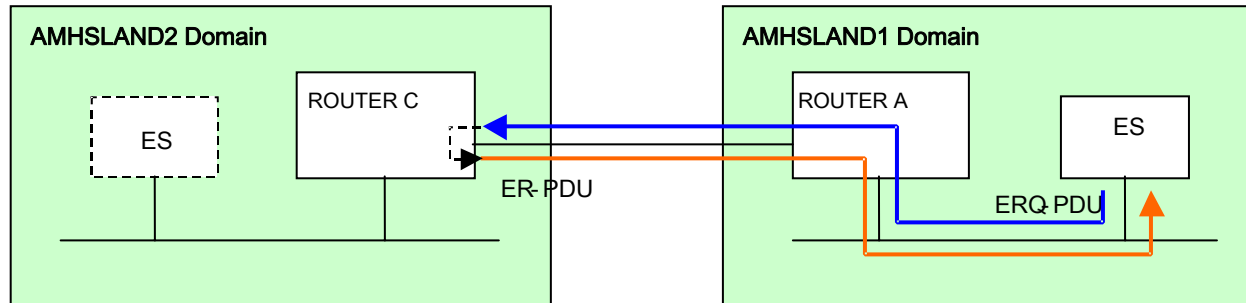

- 2-6: CLNP Echo from AMHSLAND2 End System to unreachable AMHSLAND1 End System.

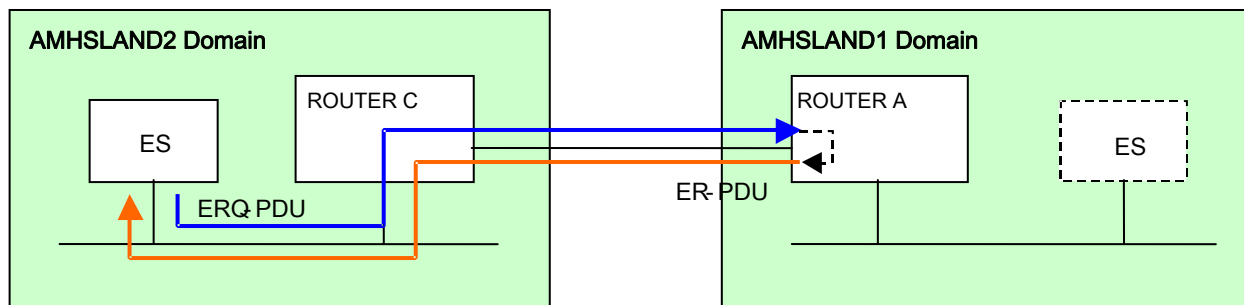

- 2-7: Routing process in AMHSLAND1 router for NPDU with invalid security parameter.

Note: Transmission of ER NPDU depends on a value in the ERQ NPDU header.

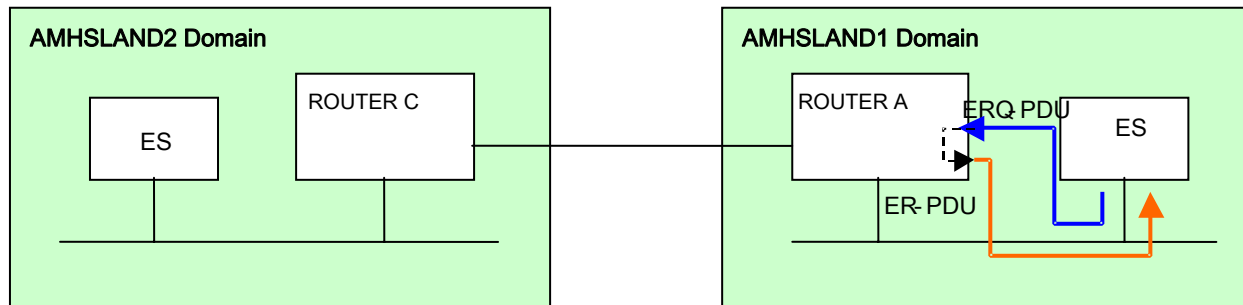

- 2-8: Routing process in AMHSLAND2 router for NPDU with invalid security parameter.

Note: Transmission of ER NPDU depends on a value in the ERQ NPDU header.

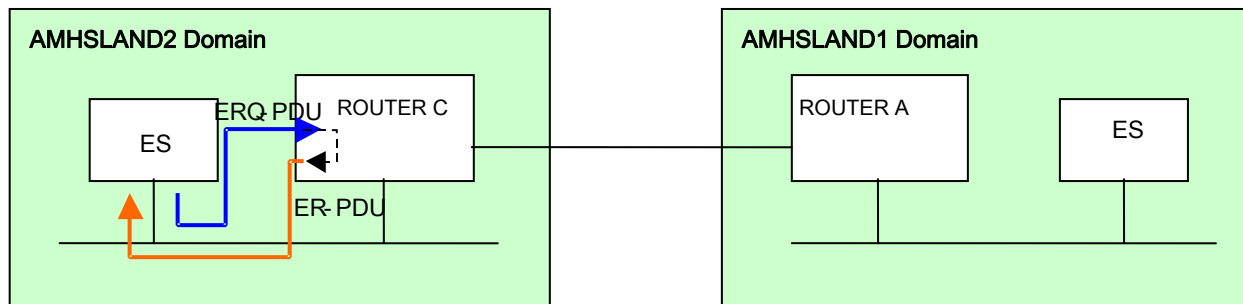

Table 10 NPDU Relay Test Procedure

2. NPDU Relay		Test Item	Procedure	Result	Date/Time
ERQ NPDU transmission from AMHSLAND1 router	ERQ NPDU transmission	2-1-1	Send ERQ NPDU from ROUTER A to ROUTER C. Confirm ROUTER C receives it.	OK / NG	/ /
	ERP NPDU transmission	2-1-2	After receiving ERQ NPDU, ROUTER C sends ERP NPDU to ROUTER A. Confirm ROUTER A receives it.	OK / NG	/ /
	Continuous ERQ/ERP NPDU transmission	2-1-3	Repeat from 2-1-1 to 2-1-2 ten times and confirm there is no problem with ERQ/ERP transmission.	OK / NG	/ /
ERQ NPDU transmission from AMHSLAND2 router	ERQ NPDU transmission	2-2-1	Send ERQ NPDU from ROUTER C to ROUTER A. Confirm ROUTER A receives it.	OK / NG	/ /
	ERP NPDU transmission	2-2-2	After receiving ERQ NPDU, ROUTER A sends an ERP NPDU to ROUTER C. Confirm ROUTER C receives it.	OK / NG	/ /
	Continuous ERQ/ERP NPDU transmission	2-2-3	Repeat from 2-2-1 to 2-2-2 ten times and confirm there is no problem with ERQ/ERP transmission.	OK / NG	/ /
ERQ NPDU transmission from AMHSLAND1 ES	ERQ NPDU transmission	2-3-1	Send ERQ NPDU from AMHSLAND1 ES to AMHSLAND2 ES. Confirm the AMHSLAND2 ES receives it.	OK / NG	/ /
	ERP NPDU transmission	2-3-2	After receiving ERQ NPDU, the AMHSLAND2 ES sends an ERP NPDU to the AMHSLAND1 ES. Confirm the AMHSLAND1 ES receives it.	OK / NG	/ /
	Continuous ERQ/ERP transmission	2-3-3	Repeat from 2-3-1 to 2-3-2 ten times and confirm there is no problem with ERQ/ERP transmission.	OK / NG	/ /
ERQ NPDU transmission from AMHSLAND2 ES	ERQ NPDU transmission	2-4-1	Send ERQ NPDU from the AMHSLAND2 ES to the AMHSLAND1 ES. Confirm the AMHSLAND1 ES receives it.	OK / NG	/ /
	ERP NPDU transmission	2-4-2	After receiving ERQ NPDU, the AMHSLAND1 ES sends an ERP NPDU to the AMHSLAND2 ES. Confirm the AMHSLAND2 ES receives it.	OK / NG	/ /
	Continuous ERQ/ERP transmission	2-4-3	Repeat from 2-4-1 to 2-4-2 ten times and confirm there is no problem with ERQ/ERP transmission.	OK / NG	/ /

2. NPDU Relay		Test Item	Procedure	Result	Date/Time
ERQ NPDU transmission from AMHSLAND1 ES to unreachable system in AMHSLAND2 domain	ERQ NPDU transmission from AMHSLAND1 ES	2-5-1	AMHSLAND1 ES sends an ERQ NPDU with destination NSAP address set to an unreachable address in AMHSLAND2 domain. Confirm ROUTER C receives it.	OK / NG	/ /
	ERQ NPDU handling in AMHSLAND2 router	2-5-2	Confirm that ROUTER C discards the ERQ NPDU from AMHSLAND1 ES. Confirm that ROUTER C sends an ER NPDU to the AMHSLAND1 ES, and that the AMHSLAND1 ES receives it.	OK / NG	/ /
ERQ NPDU transmission from AMHSLAND2 ES to unreachable system in AMHSLAND1 domain	ERQ NPDU transmission from AMHSLAND2 ES	2-6-1	AMHSLAND2 ES sends an ERQ NPDU with destination NSAP address set to an unreachable address in AMHSLAND1 domain. Confirm ROUTER A receives it.	OK / NG	/ /
	ERQ NPDU handling in AMHSLAND1 router	2-6-2	Confirm that ROUTER A discards the ERQ NPDU. Confirm that ROUTER A sends an ER NPDU to the AMHSLAND2 ES, and that the AMHSLAND2 ES receives it.	OK / NG	/ /
Routing process in AMHSLAND1 router for NPDU with invalid security option parameter	ERQ NPDU transmission from AMHSLAND1 ES	2-7-1	AMHSLAND1 ES sends an ERQ NPDU with an invalid security option parameter (ATN Systems Management Communications/No Traffic Policy Preference) addressed to the AMHSLAND2 ES. Confirm ROUTER A receives it.	OK / NG	/ /
	ERQ NPDU processing in AMHSLAND1 router	2-7-2	Confirm ROUTER A discards ERQ NPDU and sends an ER NPDU to AMHSLAND1 ES. Confirm the AMHSLAND1 ES receives the ER NPDU.	OK / NG	/ /

2. NPDU Relay		Test Item	Procedure	Result	Date/Time
Routing process in AMHSLAND2 router for NPDU with invalid security option parameter	ERQ NPDU transmission from AMHSLAND2 ES	2-8-1	AMHSLAND2 ES sends ERQ NPDU with an invalid security option parameter (ATN Systems Management Communications/No Traffic Policy Preference) addressed to the AMHSLAND1 ES. Confirm ROUTER C receives it.	OK / NG	/ /
	ERQ NPDU processing in AMHSLAND2 router	2-8-2	Confirm ROUTER C discards ERQ NPDU and ROUTER C sends an ER NPDU to the AMHSLAND2 ES. Confirm the AMHSLAND2 ES receives the ER NPDU.	OK / NG	/ /

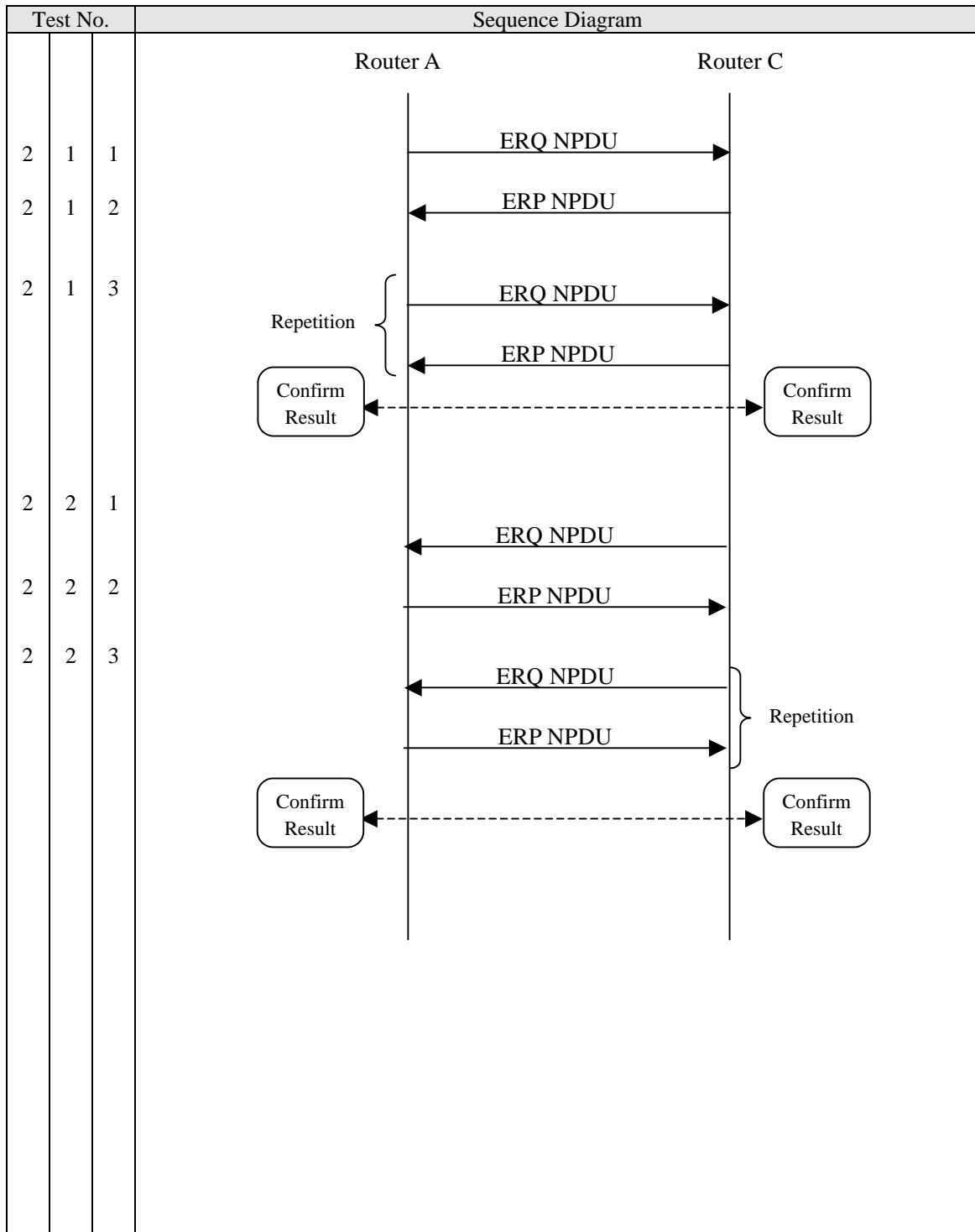

Figure 6 Sequence: NPDU Transmission between Routers

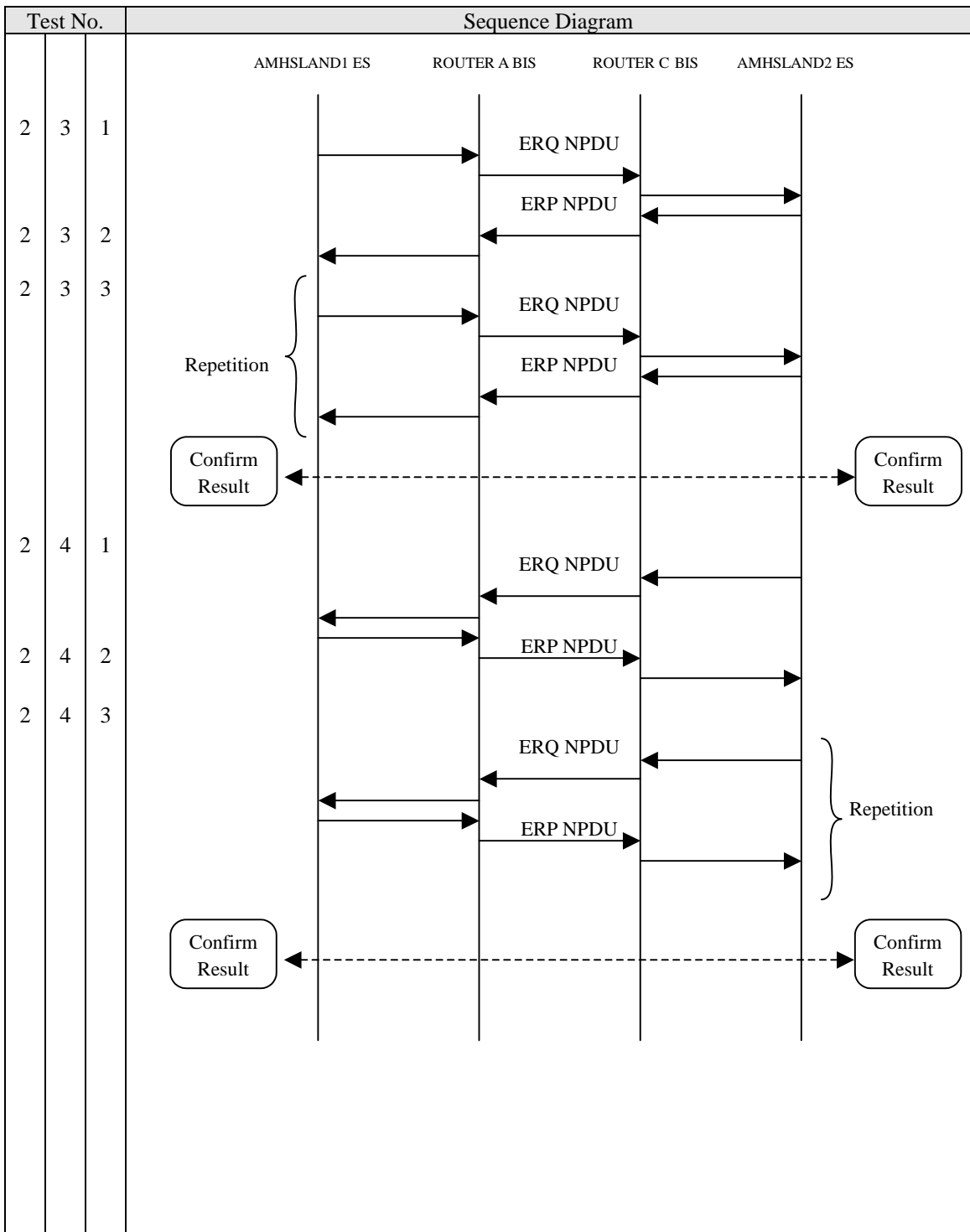

Figure 7 Sequence: NPDU Transmission between End Systems

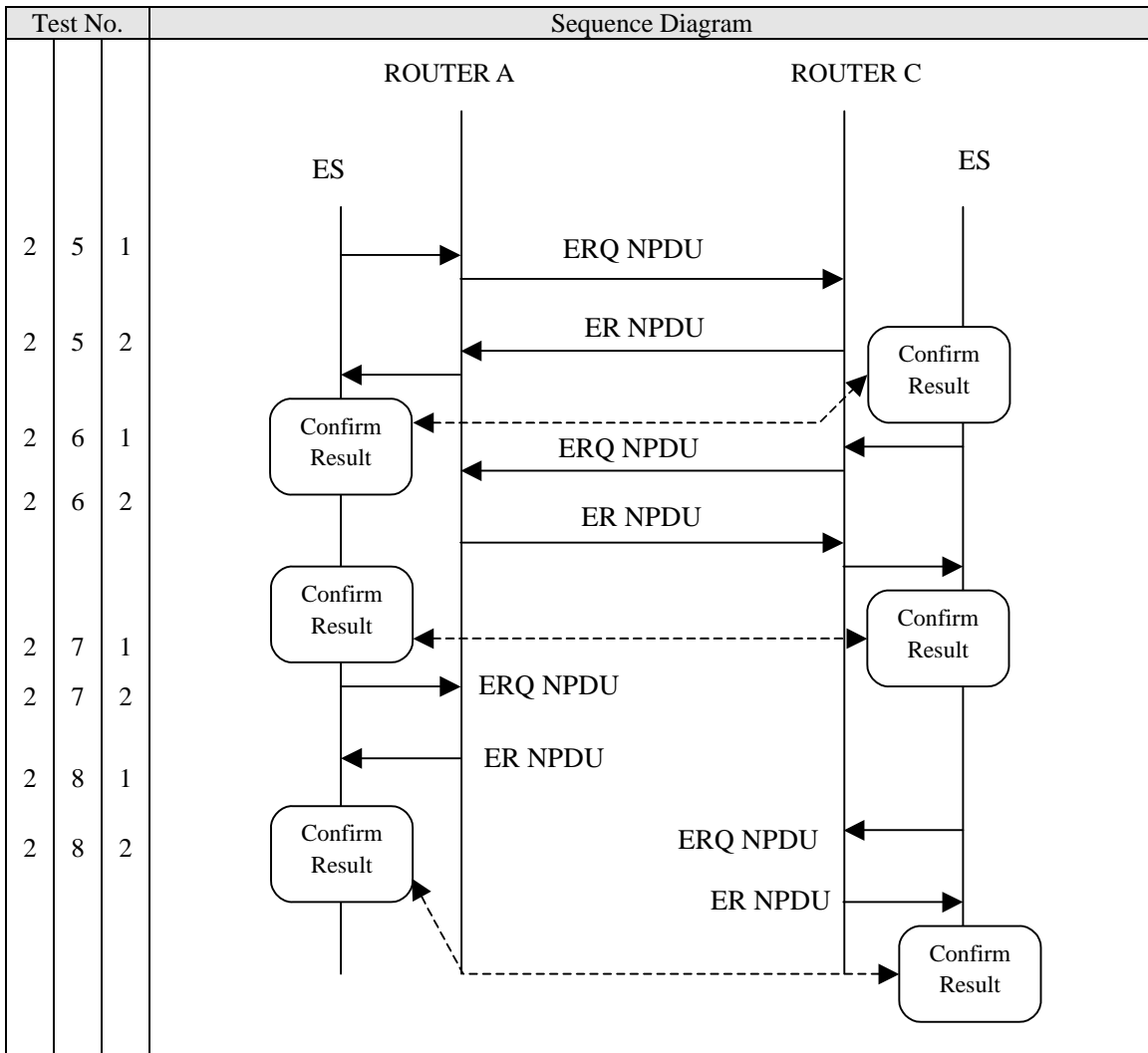

Figure 8 Sequence: NPDU Transmission to Unreachable ES and Handling of NPDU with Invalid Security Parameter

6.3. Test Case 3: Router End-to-End Tests

a) Objective

Technical trial to verify the automatic updating of routing tables in the ATN routers through IDRP protocol with routers connecting in end-to-end configuration between AMHSLAND1 and AMHSLAND2.

b) Test Configuration

The configuration for this test is shown in Figure 9.

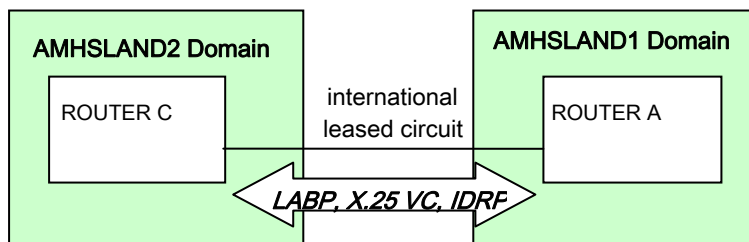

Figure 9 Router End-to-End Test Configuration

c) Test Item Overview

- 3-1: Manual router disconnection at AMHSLAND1 router and route deletion
- 3-2: Route addition (re-activation of connection) from AMHSLAND1 router
- 3-3: Manual router disconnection at AMHSLAND2 router and route deletion
- 3-4: Route addition (re-activation of connection) from AMHSLAND2 router
- 3-5: Carrier medium failure and route deletion at AMHSLAND1 router
- 3-6: Carrier medium restoration and route addition at AMHSLAND1 router
- 3-7: Carrier medium failure and route deletion at AMHSLAND2 router
- 3-8: Carrier medium restoration and route addition at AMHSLAND2 router
- 3-9: Failure and recovery of AMHSLAND1 router (redundant configuration)
- 3-10: Failure and recovery of AMHSLAND2 router

Note:

A detailed test of normal router connection (LABP, X.25 VC and IDRP) is carried out in Test Items 1-1 through 1-5, and so is not repeated here.

Table 11 Router End-to-End Tests Test Procedure

3. Router End-to-End Tests		Test Item	Procedure	Result	Date/Time
Manual router disconnection at AMHSLAND1 router and route deletion	CEASE PDU transmission from AMHSLAND1 router	3-1-1	At ROUTER A, manually close the router connection to ROUTER C. Confirm ROUTER A sends CEASE PDU.	OK / NG	/ /
	CEASE PDU transmission from AMHSLAND2 router and route deletion	3-1-2	Confirm ROUTER C receives CEASE PDU. After receiving CEASE PDU, confirm that ROUTER C sends CEASE PDU to ROUTER A, and that routing information for ROUTER A is deleted.	OK / NG	/ /
	Route deletion at AMHSLAND1 router	3-1-3	Confirm that ROUTER A receives CEASE PDU from ROUTER C, and that routing information for ROUTER C is deleted.	OK / NG	/ /
	CQ transmission	3-1-4	After IDRIP disconnected, confirm ROUTER A sends CQ packet to ROUTER C. Confirm ROUTER C receives it.	OK / NG	/ /
	CF transmission	3-1-5	After receiving CQ packet, confirm ROUTER C sends CF packet to ROUTER A. Confirm ROUTER A receives CF packet, and VC is closed.	OK / NG	/ /
Route addition (re-activation of connection) from AMHSLAND1 router	Router connection restoration after disconnection	3-2-1	At ROUTER A, manually initiate router connection with ROUTER C. (VC call: originate, OPEN PDU: send.) Confirm the router connection is re-established.	OK / NG	/ /

3. Router End-to-End Tests		Test Item	Procedure	Result	Date/Time
Manual router disconnection at AMHSLAND2 router and route deletion	CEASE PDU transmission from AMHSLAND2 router	3-3-1	At ROUTER C, manually close the router connection to ROUTER A. Confirm ROUTER C sends CEASE PDU.	OK / NG	/ /
	CEASE PDU transmission from AMHSLAND1 router and route deletion	3-3-2	Confirm ROUTER A receives CEASE PDU. After receiving CEASE PDU, confirm that ROUTER A sends CEASE PDU to ROUTER C, and that routing information for ROUTER C is deleted.	OK / NG	/ /
	Route deletion at AMHSLAND2 router	3-3-3	Confirm that ROUTER C receives CEASE PDU from ROUTER A, and that routing information for ROUTER A is deleted.	OK / NG	/ /
	CQ transmission	3-3-4	After IDRPs disconnected, confirm ROUTER C sends CQ packet to ROUTER A. Confirm ROUTER A receives it.	OK / NG	/ /
	CF transmission	3-3-5	After receiving CQ packet, confirm ROUTER A sends CF packet to ROUTER C. Confirm ROUTER C receives CF packet, and VC is closed.	OK / NG	/ /
Route addition (re-activation of connection) from AMHSLAND2 router	Router connection restoration after disconnection	3-4-1	At ROUTER C, manually initiate router connection to ROUTER A. (VC call: receive, OPEN PDU: receive.) Confirm the router connection is re-established.	OK / NG	/ /
Carrier medium failure and route deletion at AMHSLAND1 router	Data link and VC disconnection	3-5-1	At ROUTER A, simulate a circuit failure by physically disconnecting ROUTER A from the DSU/modem. Confirm that the data link and VC are disconnected between ROUTER A and ROUTER C.	OK / NG	/ /
	IDRP disconnection at AMHSLAND1	3-5-2	After circuit failure, confirm IDRPs connection at ROUTER A is closed.	OK / NG	/ /
	IDRP disconnection at AMHSLAND2	3-5-3	After circuit failure, confirm IDRPs connection at ROUTER C is closed when the IDRPs holding timer expires.	OK / NG	/ /

3. Router End-to-End Tests		Test Item	Procedure	Result	Date/Time
Carrier medium restoration and route addition at AMHSLAND1 router	Data link, VC, and router connection re-establishment	3-6-1	At ROUTER A, restore the circuit by re-connecting ROUTER A to the DSU/modem. Confirm router connection is re-established between ROUTER A and ROUTER C.	OK / NG	/ /
Carrier medium failure and route deletion at AMHSLAND2 router	Data link and VC disconnection	3-7-1	At ROUTER C, simulate a circuit failure by disconnecting the leased line circuit from the modem. Confirm data link and VC are disconnected between ROUTER A and ROUTER C.	OK / NG	/ /
	IDRP disconnection at AMHSLAND2	3-7-2	After circuit failure, confirm IDRP connection at ROUTER C is closed when the IDRP holding timer expires.	OK / NG	/ /
	IDRP disconnection at AMHSLAND1	3-7-3	After circuit failure, confirm IDRP connection at ROUTER A is closed.	OK / NG	/ /
Carrier medium restoration and route addition at AMHSLAND2 router	Data link, VC, and router connection re-establishment	3-8-1	At ROUTER C, restore circuit. Confirm the router connection is re-established between ROUTER A and ROUTER C.	OK / NG	/ /
Failure and recovery of AMHSLAND1 router	Failover from active to standby node	3-9-1	At ROUTER A, force failover from active node (#1) to standby node (#2) by rebooting active node. At ROUTER A, confirm WAN line switches from active to standby node. Confirm that router connection is closed and then re-established.	OK / NG	/ /
	Failover back to previous active node	3-9-2	At ROUTER A, force failover from active node (#2) to standby node (#1) by rebooting active node. At ROUTER A, confirm WAN line switches from active to standby node. Confirm that router connection is closed and then re-established.	OK / NG	/ /

3. Router End-to-End Tests		Test Item	Procedure	Result	Date/Time
Failure and recovery of AMHSLAND2 router	Failover from active to standby node	3-10-1	At ROUTER C, force failover from active node (#1) to standby node (#2). At ROUTER C, confirm WAN line switches from active to standby node. Confirm that router connection is closed and then re-established.	OK / NG	/ /
	Failover back to previous active node	3-10-2	At ROUTER C, force failover from active node (#2) to standby node (#1). At ROUTER C, confirm WAN line switches from active to standby node. Confirm that router connection is closed and then re-established.	OK / NG	/ /

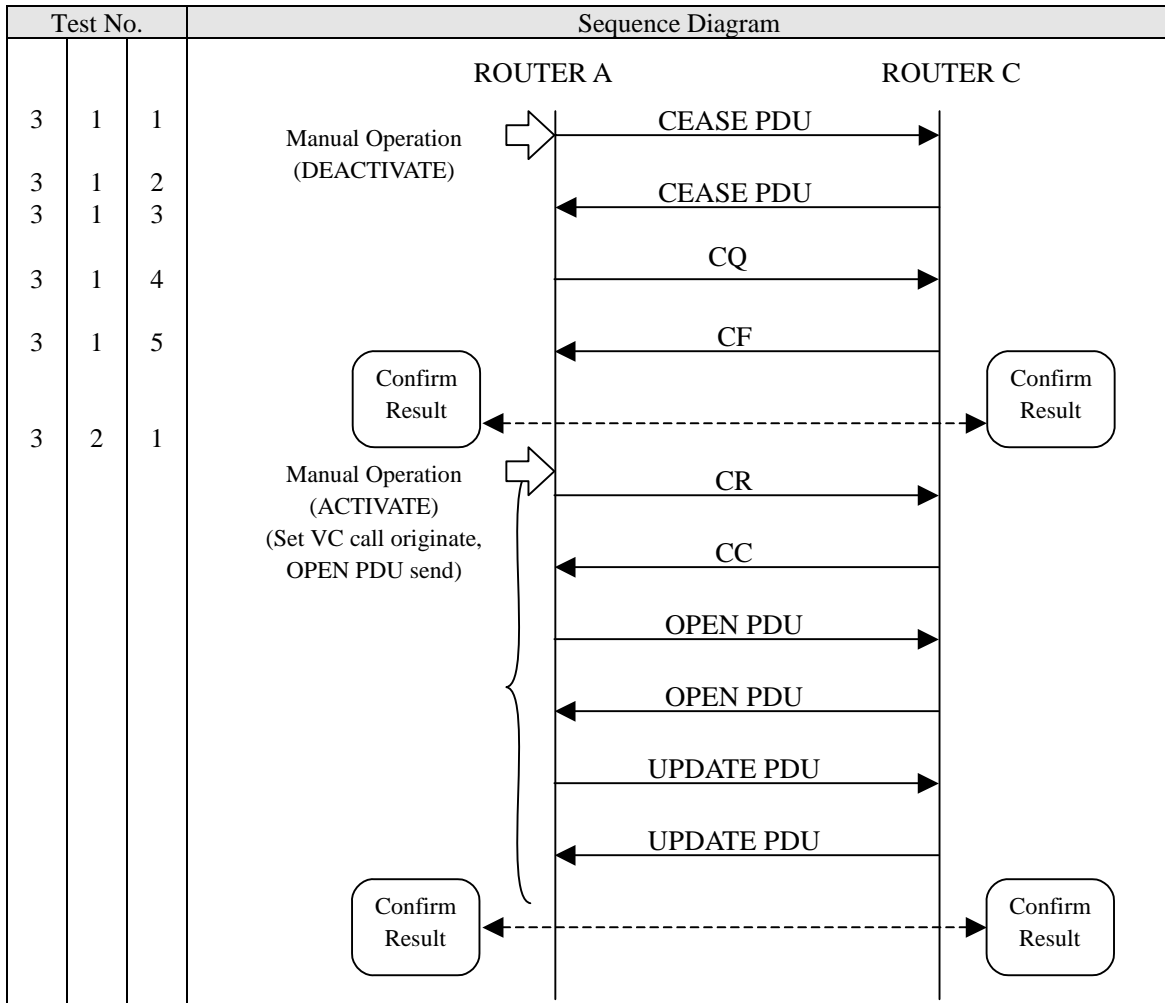

Figure 10 Sequence: Manual router Disconnection and Re-connection at AMHSLAND1 router

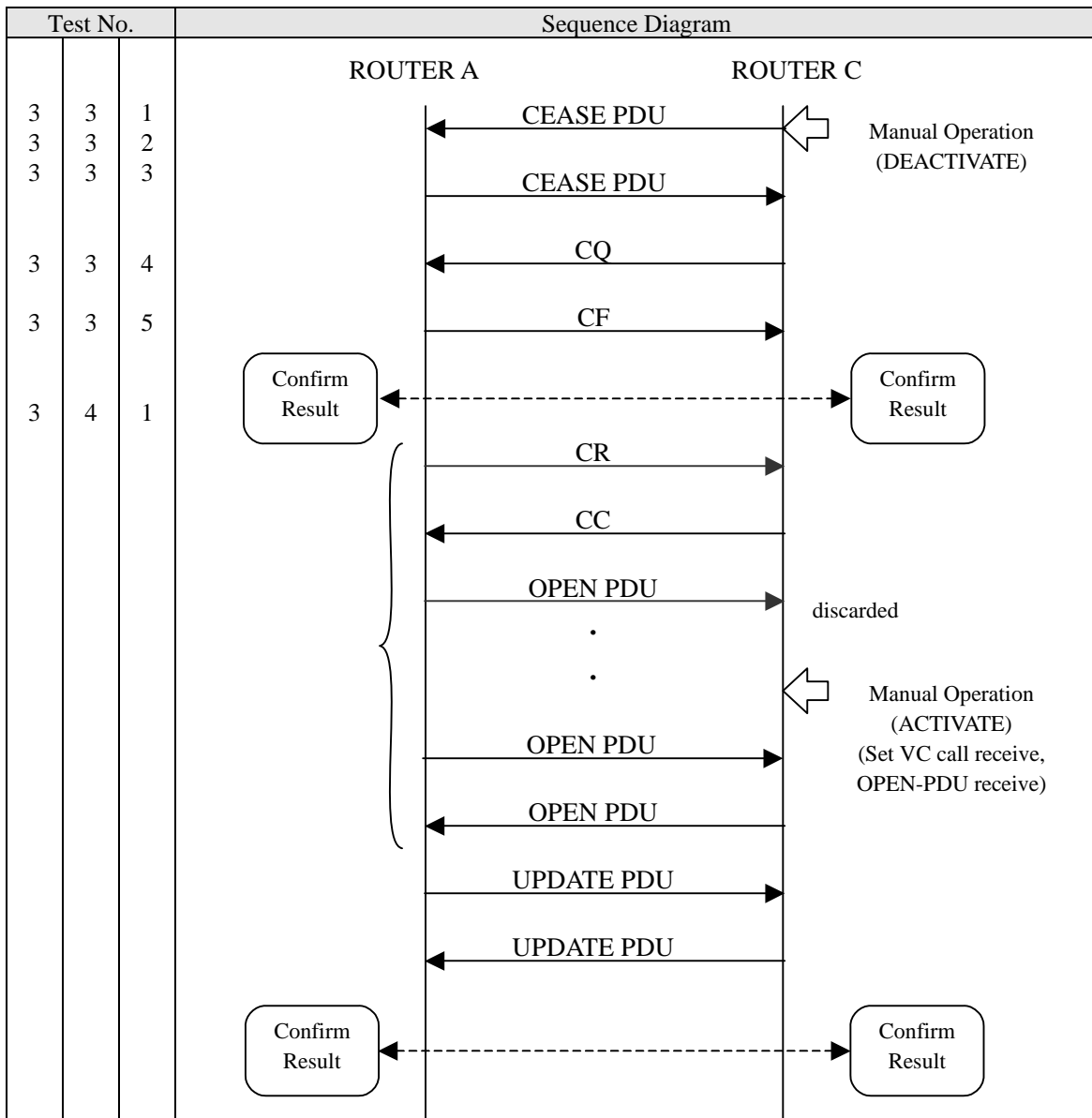

Figure 11 Sequence: Manual router Disconnection and Re-connection at AMHSLAND2 router

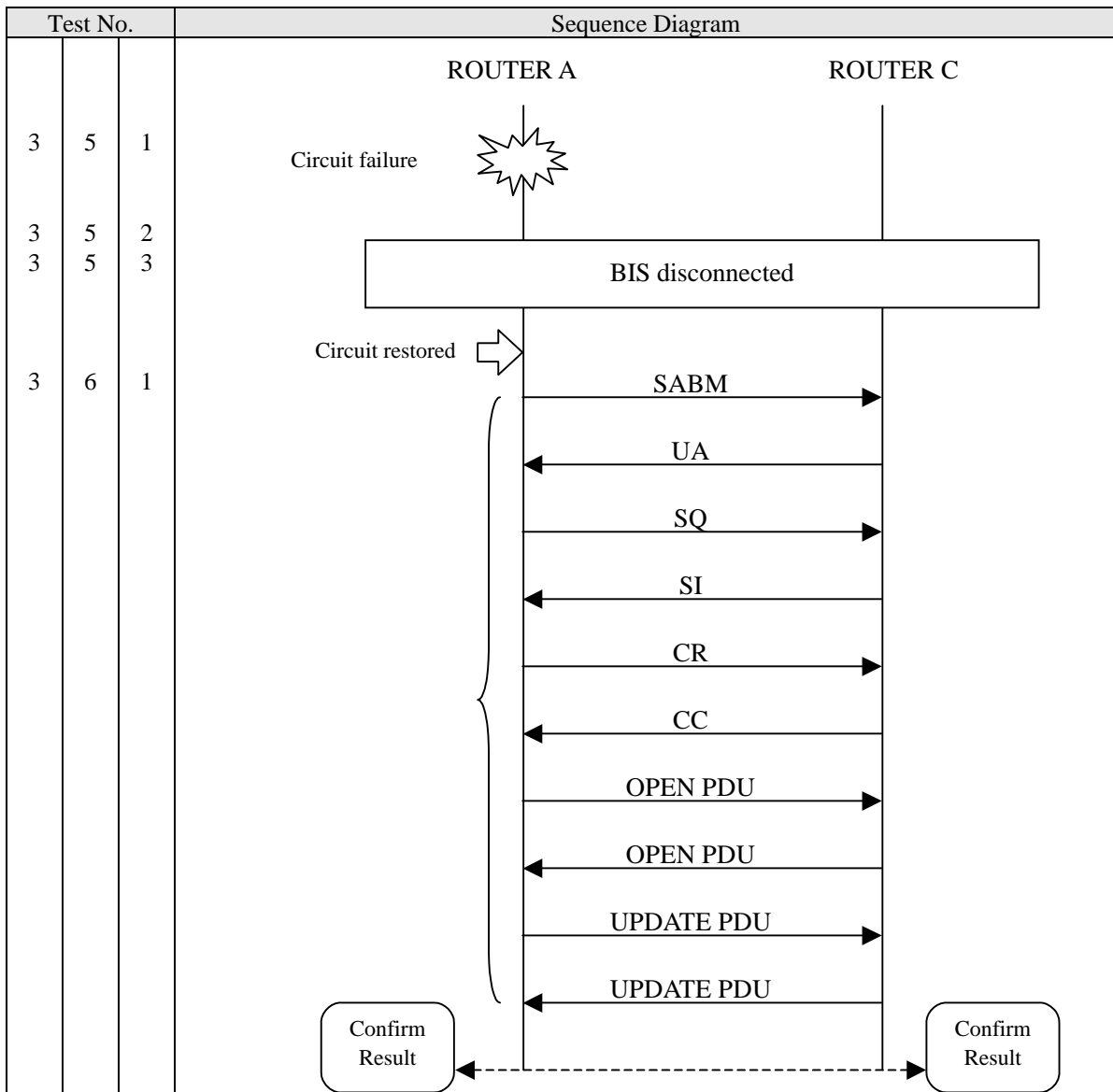

Figure 12 Sequence: Carrier medium failure and recovery at AMHSLAND1 router

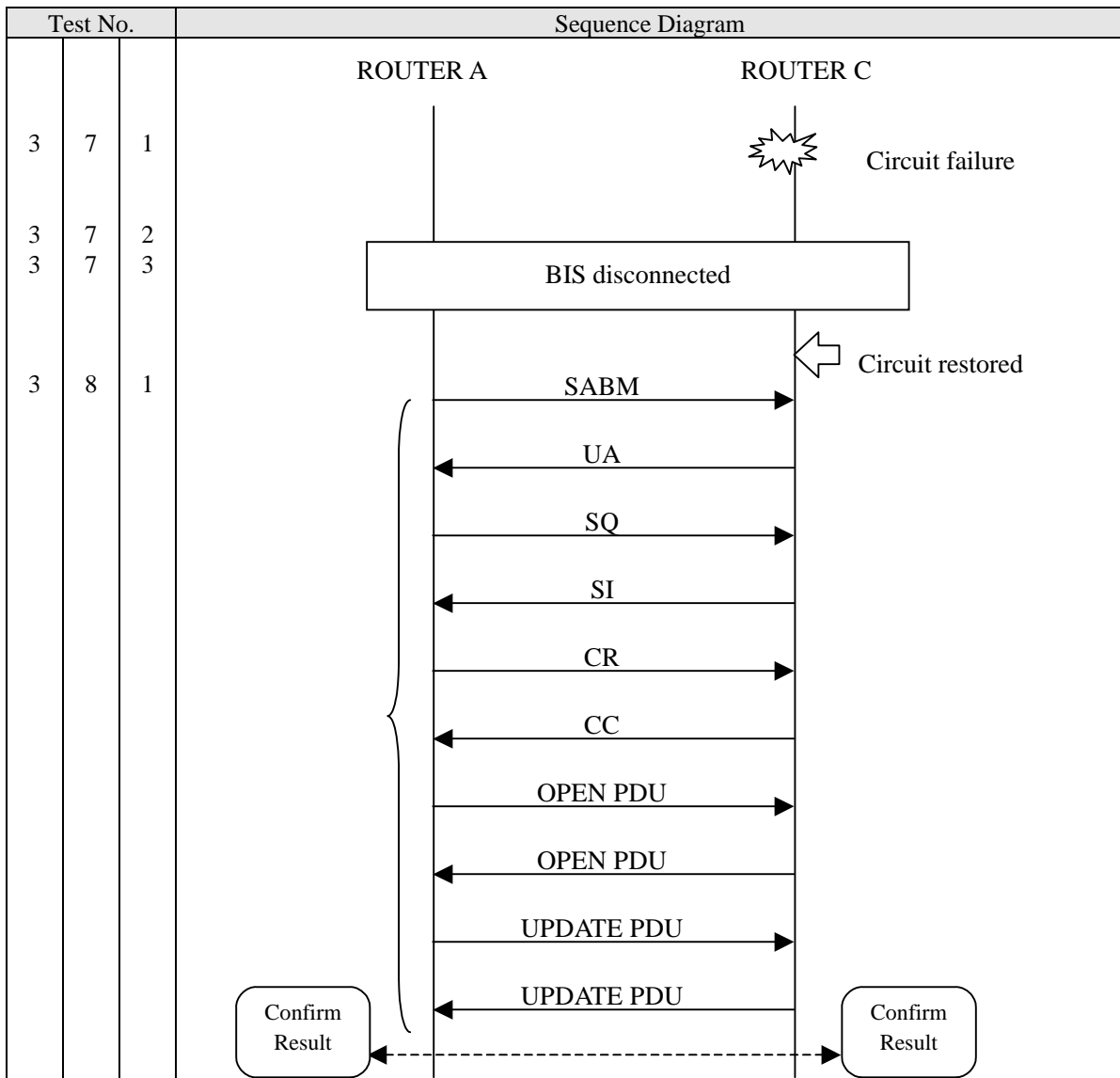

Figure 13 Sequence: Carrier medium failure and recovery at AMHSLAND2 router

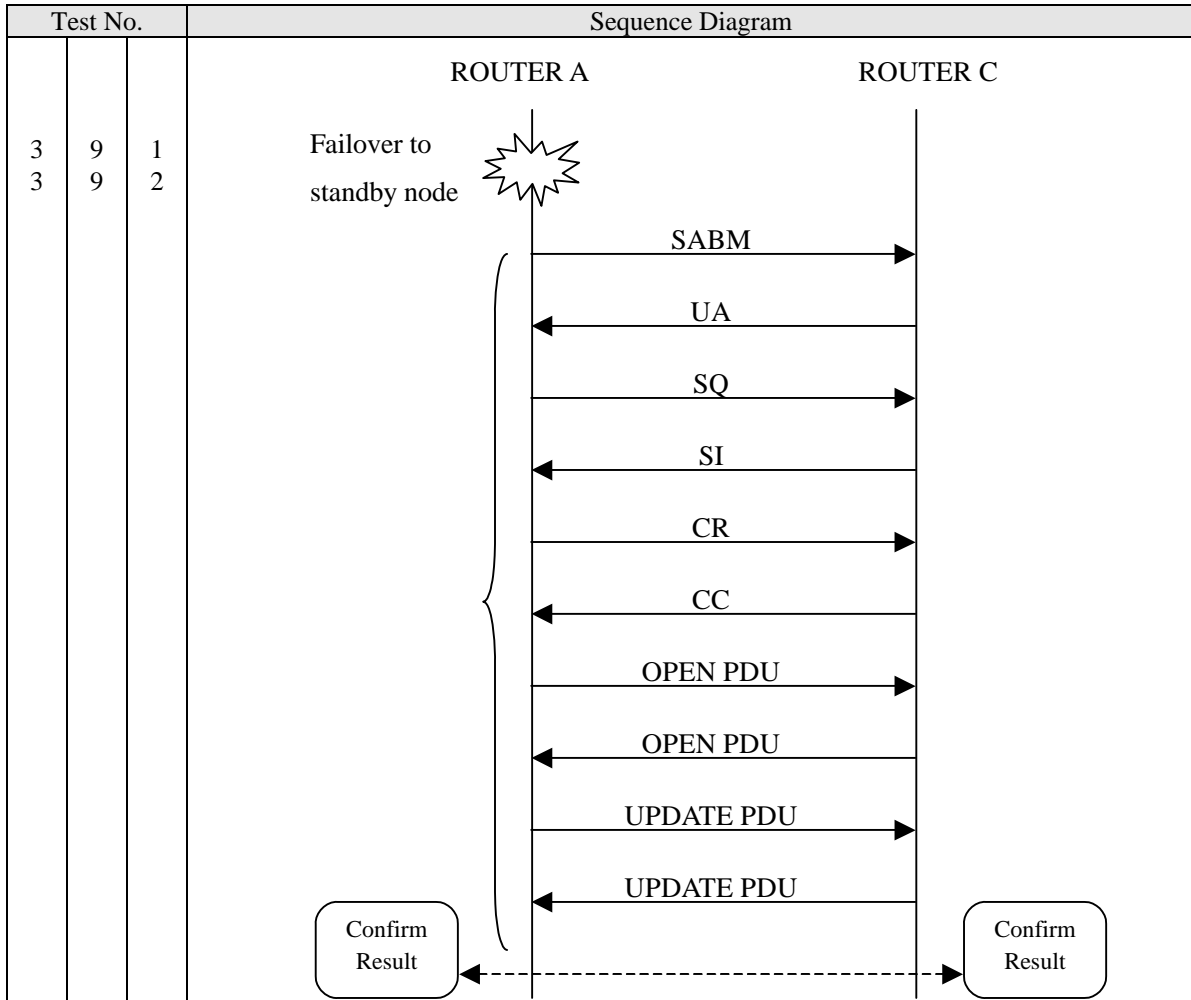

Figure 14 Sequence: AMHSLAND1 router Failure and Recovery

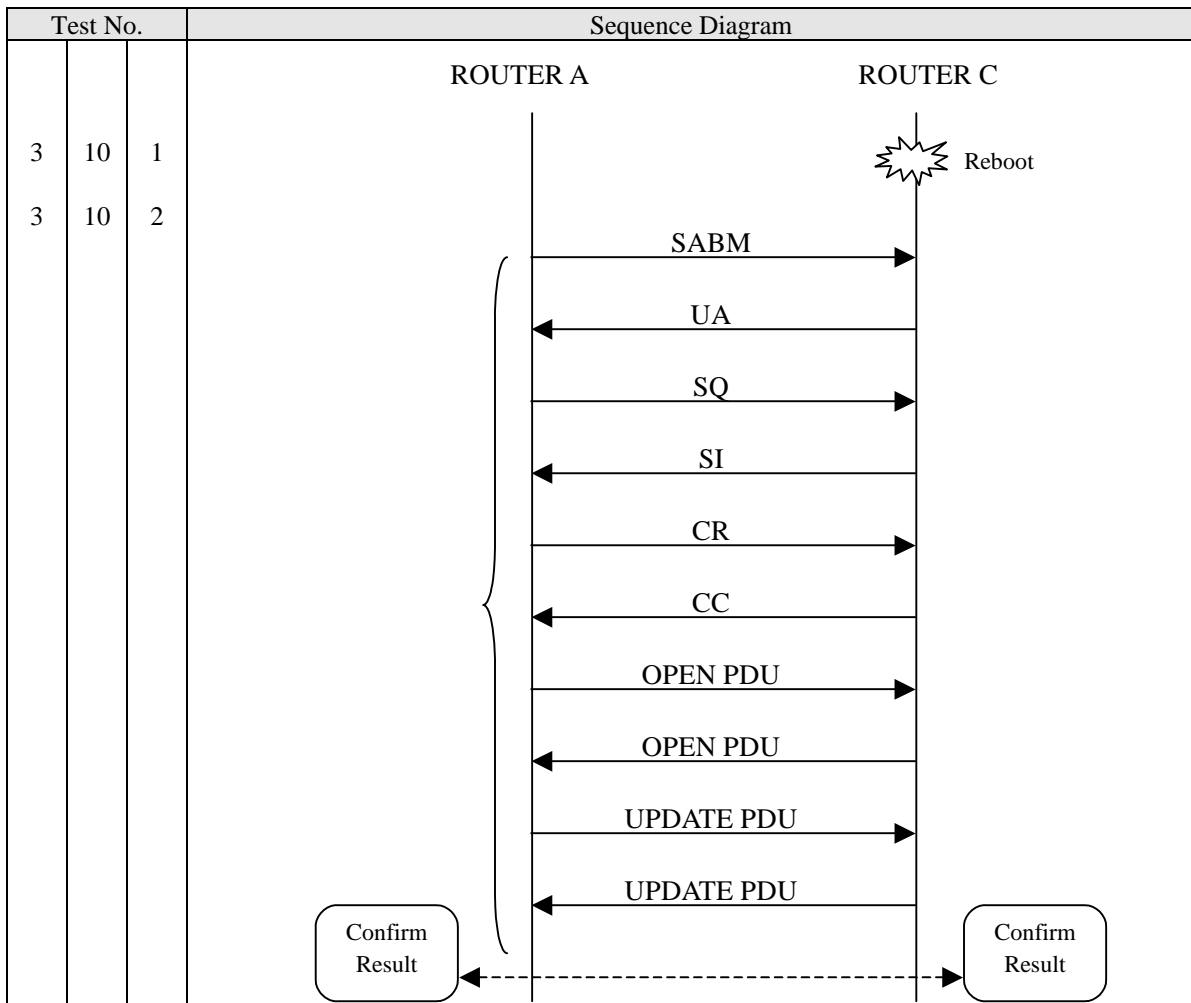

Figure 15 Sequence: AMHSLAND2 router Failure and Recovery

6.4. Test Case 4: ATN Router Tests (This cover additional tests for subnetwork)

a) Objective

Technical trial to verify the automatic updating of routing tables in ATN routers through the IDRIP protocol with routers connected in 3routers configurations between AMHSLAND1, AMHSLAND2 and simulated third domains connected to AMHSLAND1 and AMHSLAND2. The test configurations are shown below.

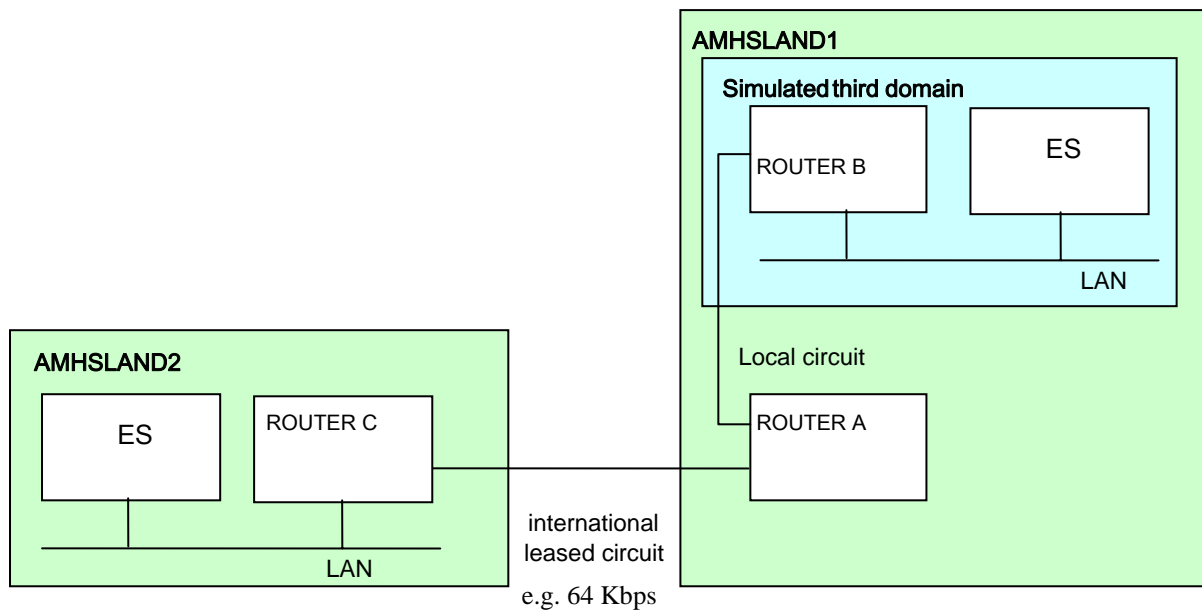

Figure 16 Test Configuration: Simulated Third Domain connected to AMHSLAND1

b) Test Overview**(i) Simulated third domain connected to AMHSLAND1.*****ROUTER CONNECTION, DISCONNECTION AND RE-ACTIVATION***

- 4-1: Router connection of ROUTER B to ROUTER A (ROUTER A-ROUTER C already established).
- 4-2, 4-3: Manual router disconnection at ROUTER A of ROUTER A-ROUTER B route and re-activation.
- 4-4, 4-5: Manual router disconnection at ROUTER B of ROUTER A-ROUTER B route and re-activation.
- 4-6: Router connection of ROUTER C to ROUTER A (ROUTER B-ROUTER A already established).
- 4-7, 4-8: Manual router disconnection at ROUTER C of ROUTER C-ROUTER A route and re-activation.
- 4-9, 4-10: Manual router disconnection at ROUTER A of ROUTER C-ROUTER A route and re-activation.

COMMUNICATION CIRCUIT FAILURE AND RECOVERY

- 4-11, 4-12: Failure and recovery of ROUTER A-ROUTER B circuit.
- 4-13, 4-14: Failure and recovery of ROUTER C-ROUTER A circuit.

ROUTER FAILURE AND RECOVERY

- 4-15: Failure and recovery of ROUTER C.
- 4-16: Failure and recovery of ROUTER A.
- 4-17: Failure and recovery of ROUTER B.

END-TO-END DATA RELAY

- 4-18: End-to-End CLNP Echo Test between End Systems in ROUTER C and ROUTER B domains.
(Subject to End System ERQ-PDU transmission capabilities.)

Table 12 Router Connection, Disconnection and Re-activation Test Procedure: Router A – Router B

4. ATN Router Tests		Test Item	Procedure	Result	Date/Time
Router connection of ROUTER B to ROUTER A	Data link establishment between ROUTER A and ROUTER B	4-1-1	With VC and IDRP connections established between ROUTER C and ROUTER A, switch on ROUTER B to initiate router connection. Check and confirm data link and VC are established between ROUTER A and ROUTER B.	OK / NG	/ /
	IDRP connection establishment between ROUTER A and ROUTER B	4-1-2	After VC establishment, check and confirm IDRP connection established between ROUTER A and ROUTER B by exchange of OPEN PDUs. (First OPEN PDU sent by ROUTER A.)	OK / NG	/ /
	UPDATE PDU transmission from ROUTER A to ROUTER B	4-1-3	After IDRP connection established, confirm ROUTER A sends an UPDATE PDU to ROUTER B. At ROUTER B, after receiving UPDATE PDU from ROUTER A, check that route information on ROUTER A and ROUTER C are added.	OK / NG	/ /
	UPDATE PDU transmission from ROUTER B to ROUTER A	4-1-4	After IDRP connection established, confirm ROUTER B sends an UPDATE PDU to ROUTER A. At ROUTER A, after receiving UPDATE PDU from ROUTER B, check and confirm route information of ROUTER B is updated correctly.	OK / NG	/ /
	UPDATE PDU transmission from ROUTER A to ROUTER C	4-1-5	At ROUTER A, after receiving UPDATE PDU from ROUTER B, confirm ROUTER A sends an UPDATE PDU to ROUTER C. At ROUTER C, confirm that UPDATE PDU is received, and that route information of ROUTER B is added.	OK / NG	/ /
Manual router disconnection at ROUTER A of ROUTER A-ROUTER B route	CEASE PDU transmission from ROUTER A	4-2-1	At ROUTER A, manually close the router connection to ROUTER B. Confirm ROUTER A sends a CEASE PDU to ROUTER B.	OK / NG	/ /
	CEASE PDU transmission from ROUTER B and route deletion	4-2-2	At ROUTER B, confirm receipt of CEASE PDU from ROUTER A. Confirm ROUTER B sends a CEASE PDU to ROUTER A, and that route information for ROUTER A and ROUTER C are deleted.	OK / NG	/ /
	Route deletion at ROUTER A	4-2-3	At ROUTER A, confirm receipt of CEASE PDU from ROUTER B, and that route information for ROUTER B is deleted.	OK / NG	/ /

4. ATN Router Tests		Test Item	Procedure	Result	Date/Time
	VC disconnection between ROUTER A and ROUTER B	4-2-4	Confirm that the VC between ROUTER A and ROUTER B is closed normally.	OK / NG	/ /
	UPDATE PDU transmission from ROUTER A to ROUTER C, and route deletion	4-2-5	Confirm that ROUTER A sends an UPDATE PDU to ROUTER C. At ROUTER C, confirm that UPDATE PDU is received from ROUTER A, and that route information for ROUTER B is deleted.	OK / NG	/ /
Route re-activation from ROUTER A	Router connection re-activation from ROUTER A	4-3-1	At ROUTER A, manually initiate router connection to ROUTER B (VC call: caller, OPEN PDU: send). Confirm the X.25 VC and IDRP connection are established.	OK / NG	/ /
	UPDATE PDU transmission from ROUTER A to ROUTER B	4-3-2	Confirm that ROUTER A sends an UPDATE PDU to ROUTER B. At ROUTER B, check that route information to ROUTER A and ROUTER C are added.	OK / NG	/ /
	UPDATE PDU transmission from ROUTER B to ROUTER A	4-3-3	Confirm that ROUTER B sends an UPDATE PDU to ROUTER A. At ROUTER A, check that route information to ROUTER B is added.	OK / NG	/ /
	UPDATE PDU transmission from ROUTER A to ROUTER C and route addition	4-3-4	Confirm that ROUTER A sends an UPDATE PDU to ROUTER C. At ROUTER C, check that route information to ROUTER B is added.	OK / NG	/ /
Manual router disconnection at ROUTER B of ROUTER A-ROUTER B route	CEASE PDU transmission from ROUTER B	4-4-1	At ROUTER B, manually close the router connection to ROUTER A. Confirm ROUTER B sends a CEASE PDU to ROUTER A.	OK / NG	/ /
	CEASE PDU transmission from ROUTER A and route deletion	4-4-2	At ROUTER A, confirm receipt of CEASE PDU from ROUTER B. Confirm ROUTER A sends CEASE PDU to ROUTER B, and that route information for ROUTER B is deleted.	OK / NG	/ /

4. ATN Router Tests		Test Item	Procedure	Result	Date/Time
	Route deletion at ROUTER B	4-4-3	At ROUTER B, confirm receipt of CEASE PDU from ROUTER A, and that route information for ROUTER A and ROUTER C are deleted.	OK / NG	/ /
	VC disconnection between ROUTER A and ROUTER B	4-4-4	Confirm that the VC between ROUTER A and ROUTER B is closed normally.	OK / NG	/ /
	UPDATE PDU transmission from ROUTER A to ROUTER C, and route deletion	4-4-5	Confirm that ROUTER A sends an UPDATE PDU to ROUTER C. At ROUTER C, confirm that an UPDATE PDU is received from ROUTER A, and that route information for ROUTER B is deleted.	OK / NG	/ /
Route re-activation from ROUTER B	Router connection re-activation from ROUTER B	4-5-1	At ROUTER B, manually initiate router connection to ROUTER A (VC call: called, OPEN PDU: receive). Confirm the X.25 VC and IDRP connection are established.	OK / NG	/ /
	UPDATE PDU transmission from ROUTER A to ROUTER B	4-5-2	Confirm that ROUTER A sends an UPDATE PDU to ROUTER B. At ROUTER B, confirm UPDATE PDU is received, and that route information to ROUTER A and ROUTER C are added.	OK / NG	/ /
	UPDATE PDU transmission from ROUTER B to ROUTER A	4-5-3	Confirm that ROUTER B sends an UPDATE PDU to ROUTER A. At ROUTER A, confirm UPDATE PDU is received, and that route information to ROUTER B is added.	OK / NG	/ /
	UPDATE PDU transmission from ROUTER A to ROUTER C and route addition	4-5-4	Confirm that ROUTER A sends an UPDATE PDU to ROUTER C. At ROUTER C, confirm UPDATE PDU is received, and that route information to ROUTER B is added.	OK / NG	/ /

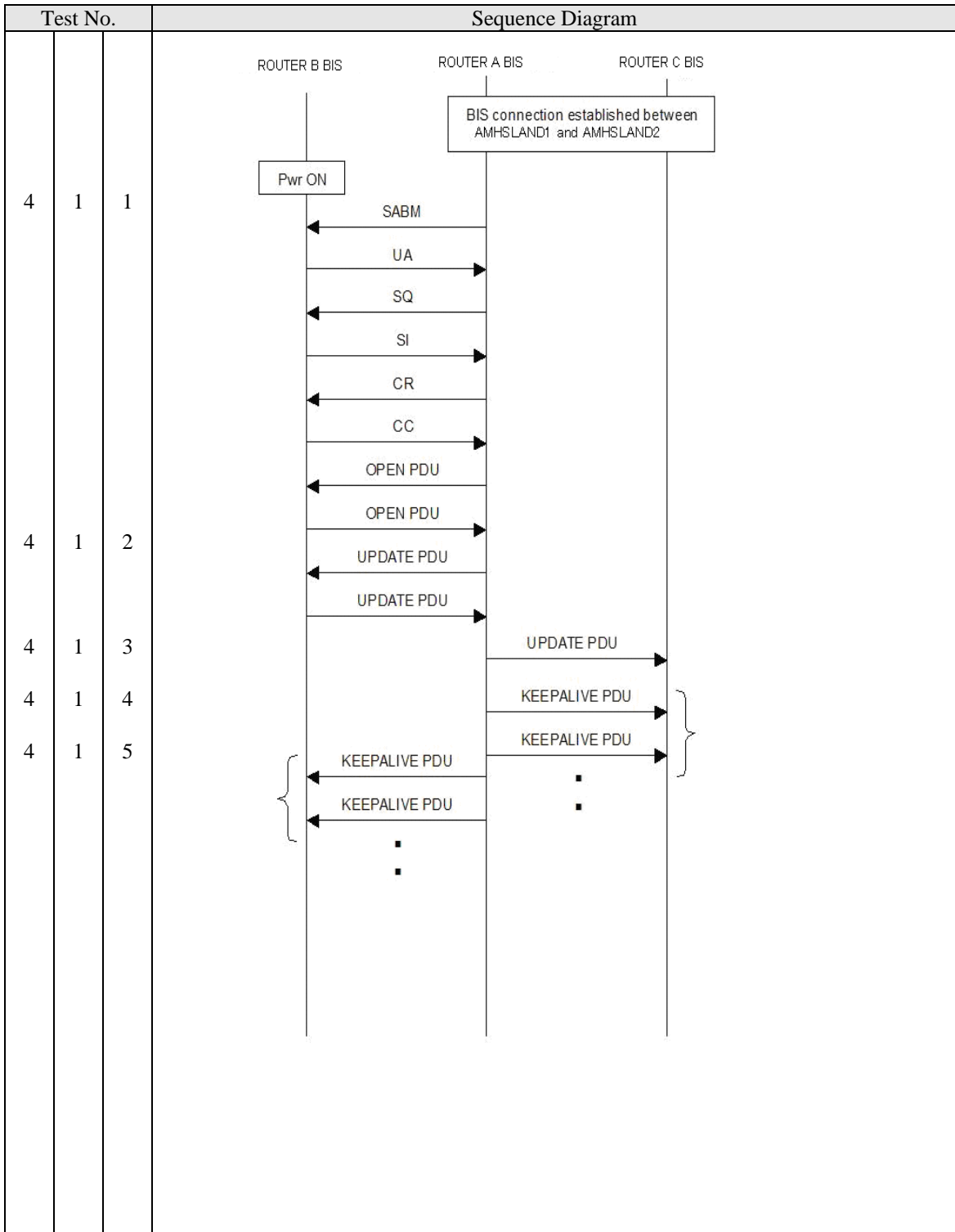

Figure 17 Sequence: router connection of ROUTER B to ROUTER A (ROUTER A-ROUTER C already established)

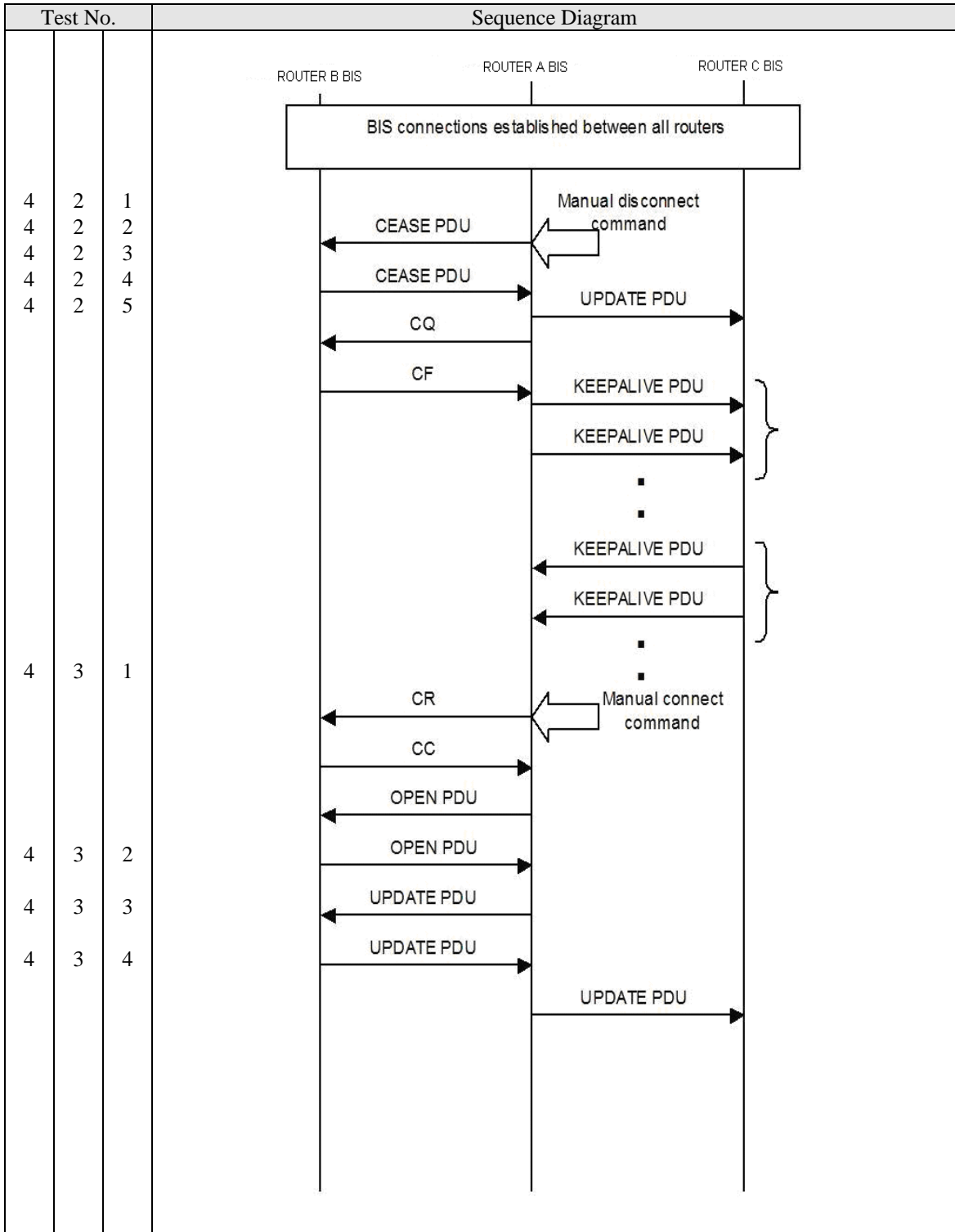

Figure 18 Sequence: Manual router disconnection at ROUTER A of ROUTER A-ROUTER B route and re-activation.

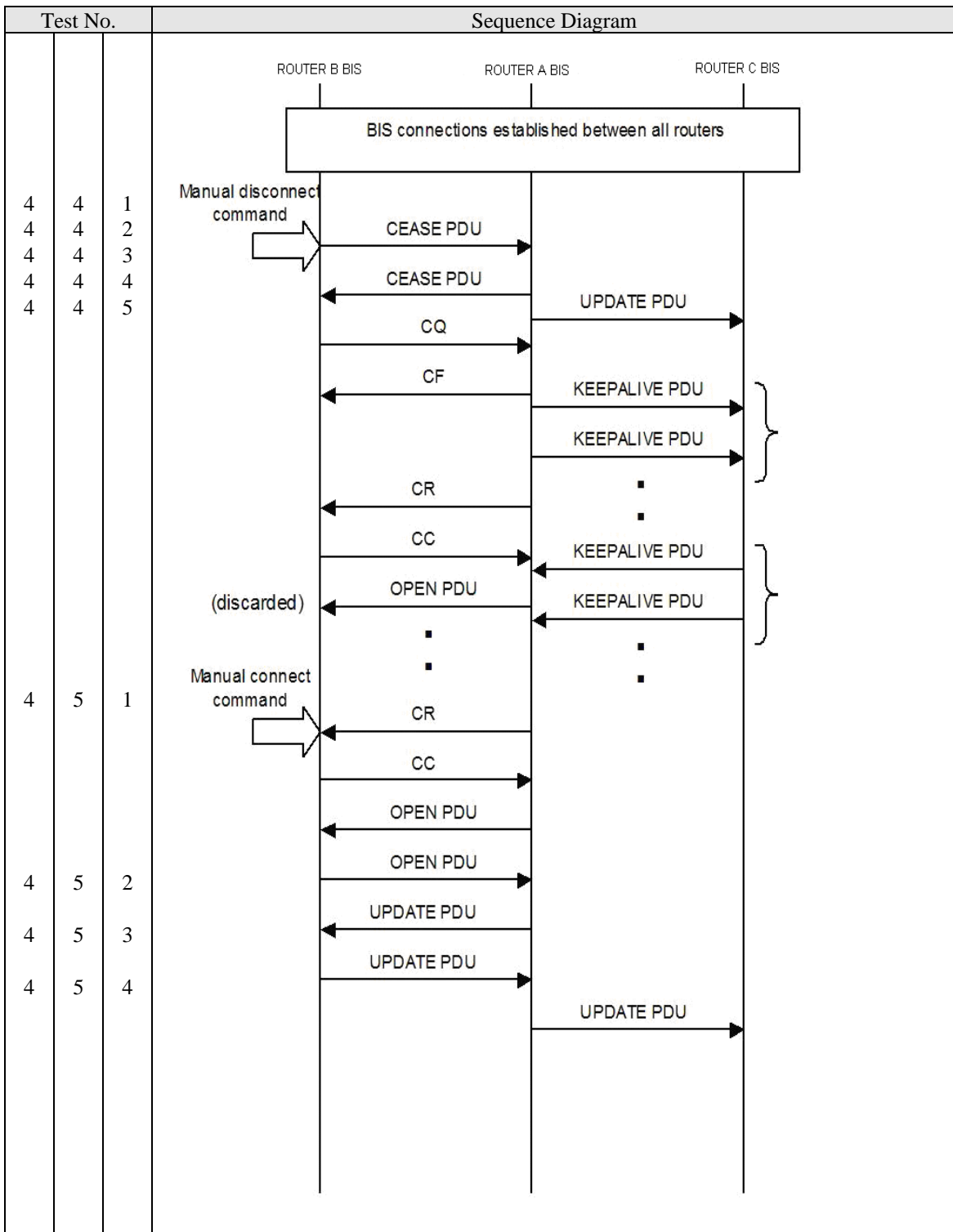

Figure 19 Sequence: Manual router disconnection at ROUTER B of ROUTER A-ROUTER B route and re-activation.

Table 13 Router Connection, Disconnection and Re-activation Test Procedure: ROUTER C-ROUTER A

4. ATN Router Tests		Test Item	Procedure	Result	Date/Time
Router connection of ROUTER C to ROUTER A	Data link establishment between ROUTER C and ROUTER A	4-6-1	With VC and IDRP connections established between ROUTER A and ROUTER B, at ROUTER A, initiate router connection to ROUTER C. Check and confirm data link and VC are established between ROUTER C and ROUTER A.	OK / NG	/ /
	IDRP connection establishment between ROUTER C and ROUTER A	4-6-2	After VC establishment, check and confirm IDRP connection established between ROUTER C and ROUTER A by exchange of OPEN PDUs. (First OPEN PDU sent by ROUTER A.)	OK / NG	/ /
	UPDATE PDU transmission from ROUTER A to ROUTER C	4-6-3	After IDRP connection established, confirm ROUTER A sends an UPDATE PDU to ROUTER C. At ROUTER C, after receiving UPDATE PDU from ROUTER A, check that route information on ROUTER A and ROUTER B are added.	OK / NG	/ /
	UPDATE PDU transmission from ROUTER C to ROUTER A	4-6-4	After IDRP connection established, confirm ROUTER C sends an UPDATE PDU to ROUTER A. At ROUTER A, after receiving UPDATE PDU from ROUTER C, confirm route information of ROUTER C is added.	OK / NG	/ /
	UPDATE PDU transmission from ROUTER A to ROUTER B	4-6-5	At ROUTER A, after receiving UPDATE PDU from ROUTER C, confirm ROUTER A sends an UPDATE PDU to ROUTER B. At ROUTER B, after receiving UPDATE PDU from ROUTER A, confirm that route information of ROUTER C is added.	OK / NG	/ /
Manual router disconnection at ROUTER C of ROUTER C-ROUTER A route	CEASE PDU transmission from ROUTER C	4-7-1	At ROUTER C, manually close the router connection to ROUTER A. Confirm ROUTER C sends a CEASE PDU to ROUTER A.	OK / NG	/ /
	CEASE PDU transmission from ROUTER A and route deletion	4-7-2	At ROUTER A, confirm receipt of CEASE PDU from ROUTER C. Confirm ROUTER A sends CEASE PDU to ROUTER C, and that route information for ROUTER C is deleted.	OK / NG	/ /

4. ATN Router Tests		Test Item	Procedure	Result	Date/Time
	Route deletion at ROUTER C	4-7-3	At ROUTER C, confirm receipt of CEASE PDU from ROUTER A, and that route information for ROUTER A and ROUTER B are deleted.	OK / NG	/ /
	VC disconnection between ROUTER C and ROUTER A	4-7-4	Confirm that the VC between ROUTER C and ROUTER A is closed normally.	OK / NG	/ /
	UPDATE PDU transmission from ROUTER A to ROUTER B, and route deletion	4-7-5	Confirm that ROUTER A sends an UPDATE PDU to ROUTER B. At ROUTER B, confirm that UPDATE PDU is received from ROUTER A, and that route information for ROUTER C is deleted.	OK / NG	/ /
Route re-activation from ROUTER C	Router connection re-activation from ROUTER C	4-8-1	At ROUTER C, manually initiate router connection to ROUTER A (VC call: called, OPEN PDU: receive). Confirm the X.25 VC and IDRP connection are established.	OK / NG	/ /
	UPDATE PDU transmission from ROUTER A to ROUTER C	4-8-2	Confirm that ROUTER A sends an UPDATE PDU to ROUTER C. At ROUTER C, confirm UPDATE PDU is received, and that route information to ROUTER A and ROUTER B are added.	OK / NG	/ /
	UPDATE PDU transmission from ROUTER C to ROUTER A	4-8-3	Confirm that ROUTER C sends an UPDATE PDU to ROUTER A. At ROUTER A, confirm UPDATE PDU is received, and that route information to ROUTER C is added.	OK / NG	/ /
	UPDATE PDU transmission from ROUTER A to ROUTER B and route addition	4-8-4	Confirm that ROUTER A sends an UPDATE PDU to ROUTER B. At ROUTER B, confirm that UPDATE PDU is received, and that route information to ROUTER C is added.	OK / NG	/ /
Manual router disconnection at ROUTER A of ROUTER C-ROUTER A route	CEASE PDU transmission from ROUTER A	4-9-1	At ROUTER A, manually close the router connection to ROUTER C. Confirm ROUTER A sends a CEASE PDU to ROUTER C.	OK / NG	/ /

4. ATN Router Tests		Test Item	Procedure	Result	Date/Time
	CEASE PDU transmission from ROUTER C and route deletion	4-9-2	At ROUTER C, confirm receipt of CEASE PDU from ROUTER A, and that route information for ROUTER A and ROUTER B are deleted.	OK / NG	/ /
	Route deletion at ROUTER A	4-9-3	At ROUTER A, confirm receipt of CEASE PDU from ROUTER C, and that route information for ROUTER C is deleted.	OK / NG	/ /
	VC disconnection between ROUTER C and ROUTER A	4-9-4	Confirm that the VC between ROUTER C and ROUTER A is closed normally.	OK / NG	/ /
	UPDATE PDU transmission from ROUTER A to ROUTER B, and route deletion	4-9-5	Confirm that ROUTER A sends an UPDATE PDU to ROUTER B. At ROUTER B, confirm UPDATE PDU is received from ROUTER A, and that route information for ROUTER C is deleted.	OK / NG	/ /
Route re-activation from ROUTER A	Router connection re-activation from ROUTER A	4-10-1	At ROUTER A, manually initiate router connection to ROUTER C (VC call: caller, OPEN PDU: send). Confirm the X.25 VC and IDRP connection are established.	OK / NG	/ /
	UPDATE PDU transmission from ROUTER A to ROUTER C	4-10-2	Confirm that ROUTER A sends an UPDATE PDU to ROUTER C. At ROUTER C, confirm UPDATE PDU is received, and that route information to ROUTER A and ROUTER B are added.	OK / NG	/ /
	UPDATE PDU transmission from ROUTER C to ROUTER A	4-10-3	Confirm that ROUTER C sends an UPDATE PDU to ROUTER A. At ROUTER A, confirm UPDATE PDU is received, and that route information to ROUTER C is added.	OK / NG	/ /
	UPDATE PDU transmission from ROUTER A to ROUTER B and route addition	4-10-4	Confirm that ROUTER A sends an UPDATE PDU to ROUTER B. At ROUTER B, confirm UPDATE PDU is received, and that route information to ROUTER C is added.	OK / NG	/ /

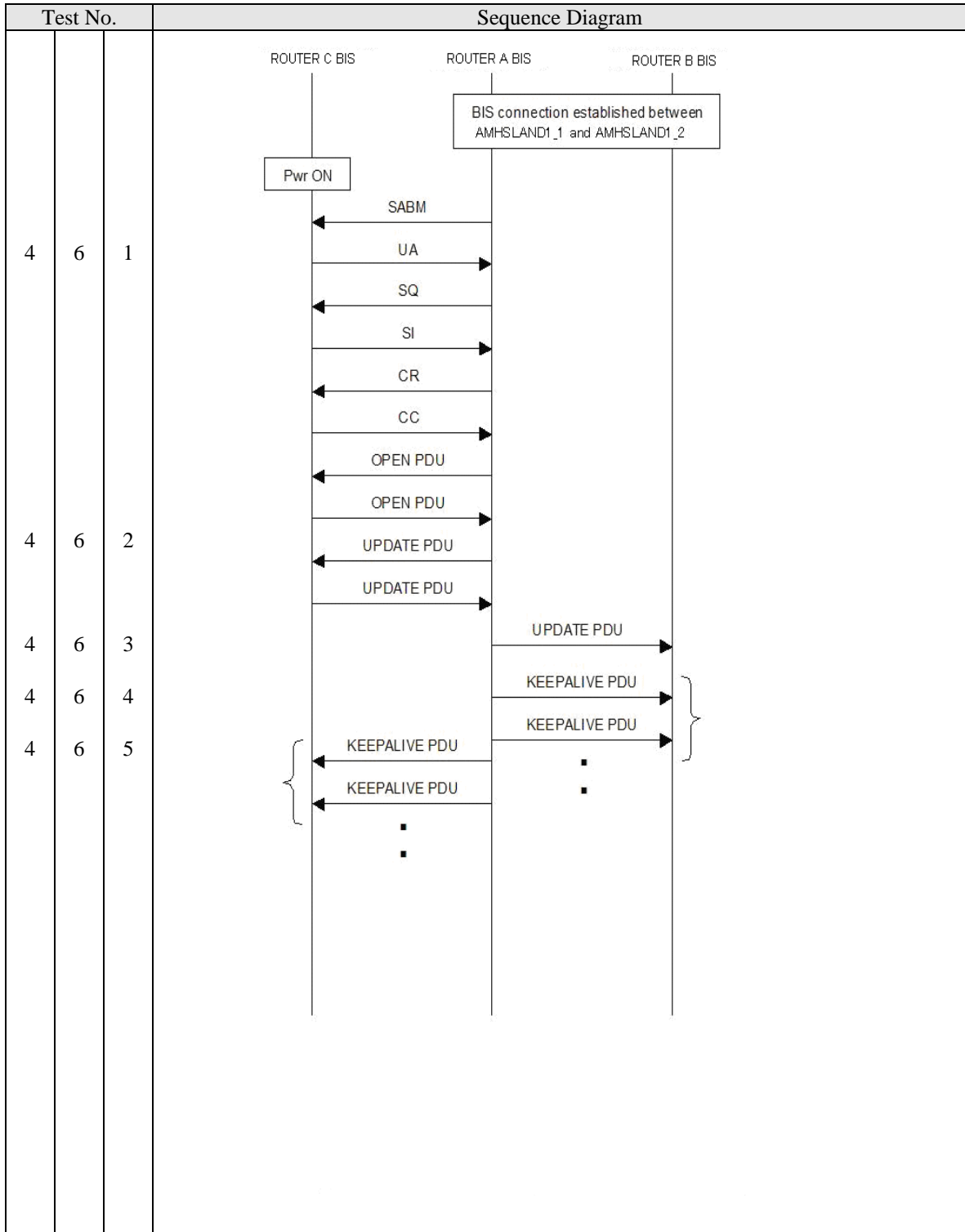

Figure 20 Sequence: Router connection of ROUTER C to ROUTER A (ROUTER B-ROUTER A already established)

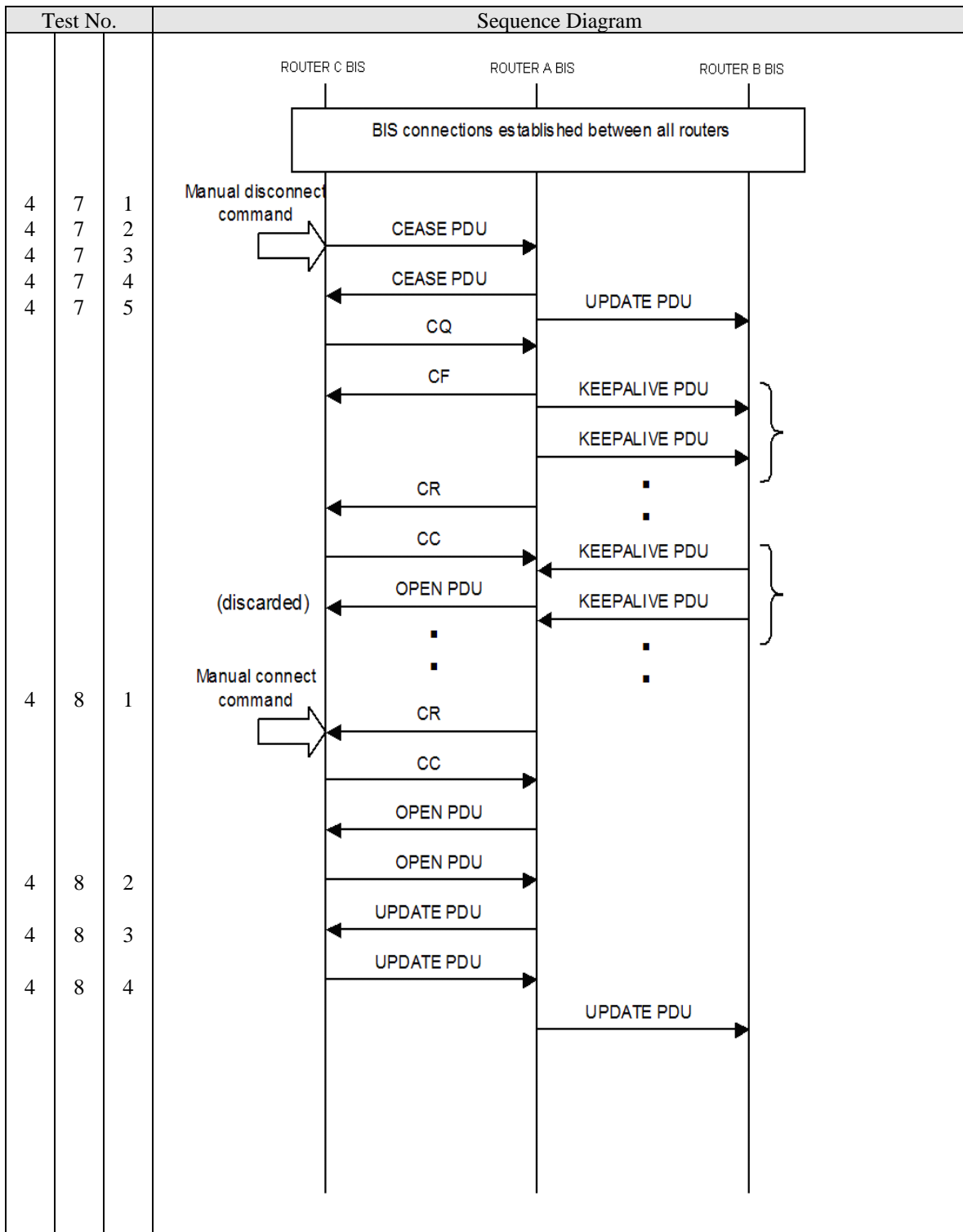

Figure 21 Sequence: Manual router disconnection at ROUTER C of ROUTER C-ROUTER A route and re-activation

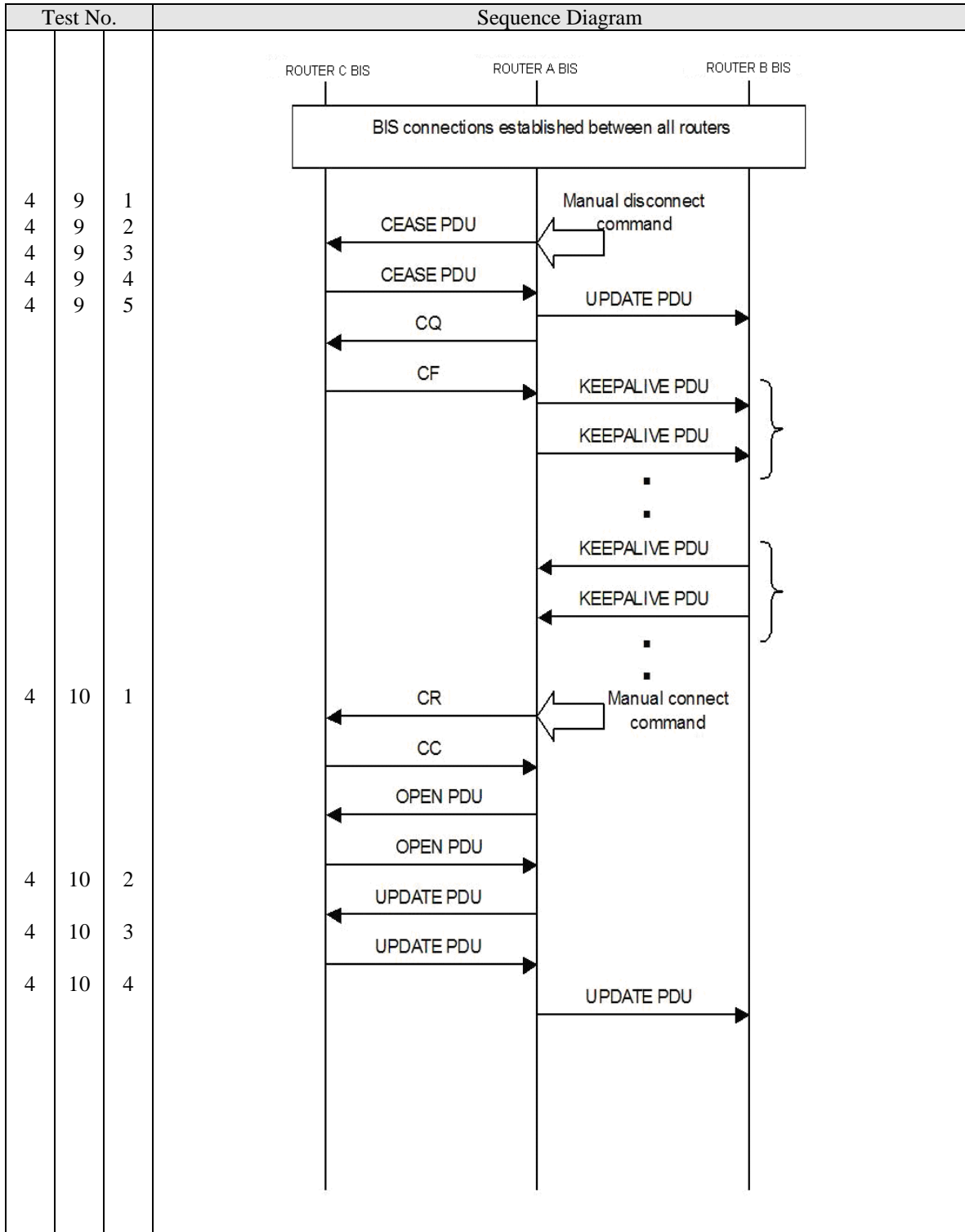

Figure 22 Sequence: Manual router disconnection at ROUTER A of ROUTER C-ROUTER A route and re-activation

Table 14 Communication Circuit Failure and Recovery Test Procedure: Third Domain connected to AMHSLAND1

4. ATN Router Tests		Test Item	Procedure	Result	Date/Time
Carrier media failure of ROUTER A-ROUTER B circuit and route deletion	Data link and VC disconnection	4-11-1	Simulate carrier medium failure between ROUTER A and ROUTER B by disconnecting WAN cable from ROUTER B. Check and confirm data link and VC are disconnected between ROUTER A and ROUTER B.	OK / NG	/ /
	IDRP disconnection and route update	4-11-2	Check and confirm that IDRP connection between ROUTER A and ROUTER B is closed. At ROUTER A, check that route information for ROUTER B is deleted. At ROUTER B, check that route information for ROUTER A and ROUTER C is deleted.	OK / NG	/ /
	UPDATE PDU transmission from ROUTER A and route update	4-11-3	Check that ROUTER A sends an UPDATE PDU to ROUTER C. At ROUTER C, check UPDATE PDU is received from ROUTER A, and that route information for ROUTER B is deleted.	OK / NG	/ /
Carrier media restoration of ROUTER A-ROUTER B circuit and route addition	Data link, VC, and router connection re-establishment	4-12-1	Restore the ROUTER A-ROUTER B router connection. Confirm router connection is re-established between ROUTER A and ROUTER B.	OK / NG	/ /
	UPDATE PDU transmission from ROUTER A	4-12-2	After IDRP connection is established, confirm that ROUTER A sends an UPDATE PDU to ROUTER B. At ROUTER B, check that an UPDATE PDU is received from ROUTER A, and that route information for ROUTER A and ROUTER C are added.	OK / NG	/ /
	UPDATE PDU transmission from ROUTER B	4-12-3	After receiving UPDATE PDU from ROUTER A, check that ROUTER B sends an UPDATE PDU to ROUTER A. At ROUTER A, after receiving UPDATE PDU from ROUTER B, check that route information is added for ROUTER B.	OK / NG	/ /
	UPDATE PDU transmission from ROUTER A	4-12-4	Check that ROUTER A sends an UPDATE PDU to ROUTER C. At ROUTER C, check that an UPDATE PDU is received from ROUTER A, and that route information is added for ROUTER B.	OK / NG	/ /

4. ATN Router Tests		Test Item	Procedure	Result	Date/Time
Carrier media failure of ROUTER C-ROUTER A circuit and route deletion	Data link and VC disconnection	4-13-1	Simulate carrier medium failure between ROUTER C and ROUTER A by disconnecting WAN cable from ROUTER C. Check and confirm data link and VC are disconnected between ROUTER C and ROUTER A.	OK / NG	/ /
	IDRP disconnection and route update	4-13-2	Check and confirm that IDRP connection between ROUTER C and ROUTER A is closed. At ROUTER C, check that route information for ROUTER A and ROUTER B are deleted. At ROUTER A, check that route information for ROUTER C is deleted.	OK / NG	/ /
	UPDATE PDU transmission from ROUTER A and route update	4-13-3	Check that ROUTER A sends an UPDATE PDU to ROUTER B. At ROUTER B, check that UPDATE PDU is received from ROUTER A, and that route information for ROUTER C is deleted.	OK / NG	/ /
Carrier media restoration of ROUTER C-ROUTER A circuit and route addition	Data link, VC, and Router connection re-establishment	4-14-1	Restore the ROUTER C-ROUTER A router connection. Confirm router connection is re-established between ROUTER C and ROUTER A.	OK / NG	/ /
	UPDATE PDU transmission from ROUTER A	4-14-2	After IDRP connection is established, confirm that ROUTER A sends an UPDATE PDU to ROUTER C. At ROUTER C, check that an UPDATE PDU is received from ROUTER A, and that route information for ROUTER A and ROUTER B are added.	OK / NG	/ /
	UPDATE PDU transmission from ROUTER C	4-14-3	After receiving UPDATE PDU from ROUTER A, check that ROUTER C sends an UPDATE PDU to ROUTER A. At ROUTER A, after receiving UPDATE PDU from ROUTER C, check that route information is added for ROUTER C.	OK / NG	/ /
	UPDATE PDU transmission from ROUTER A	4-14-4	Check that ROUTER A sends an UPDATE PDU to ROUTER B. At ROUTER B, check that an UPDATE PDU is received from ROUTER A, and that route information is added for ROUTER C.	OK / NG	/ /

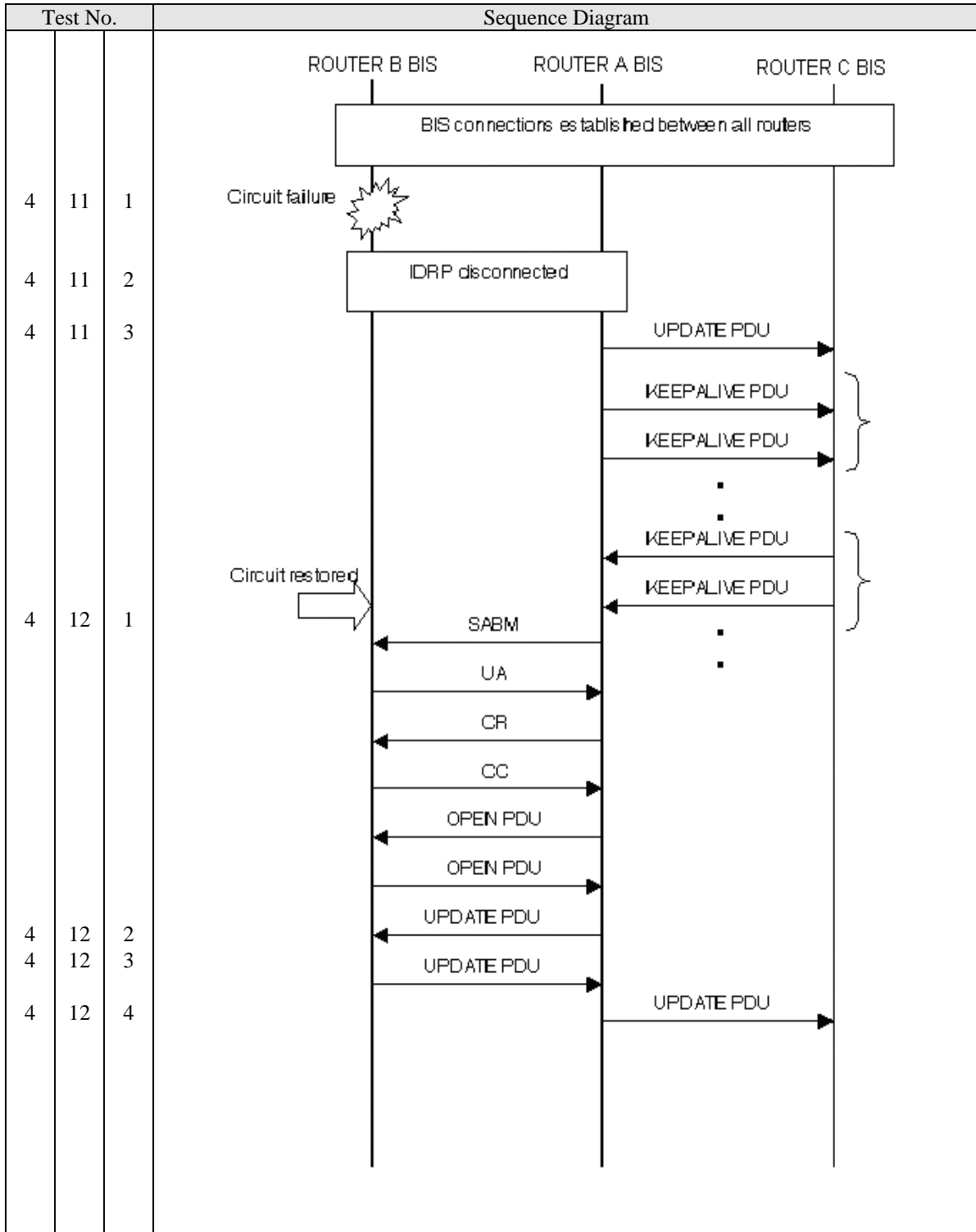

Figure 23 Sequence: Failure and recovery of ROUTER B-ROUTER A circuit

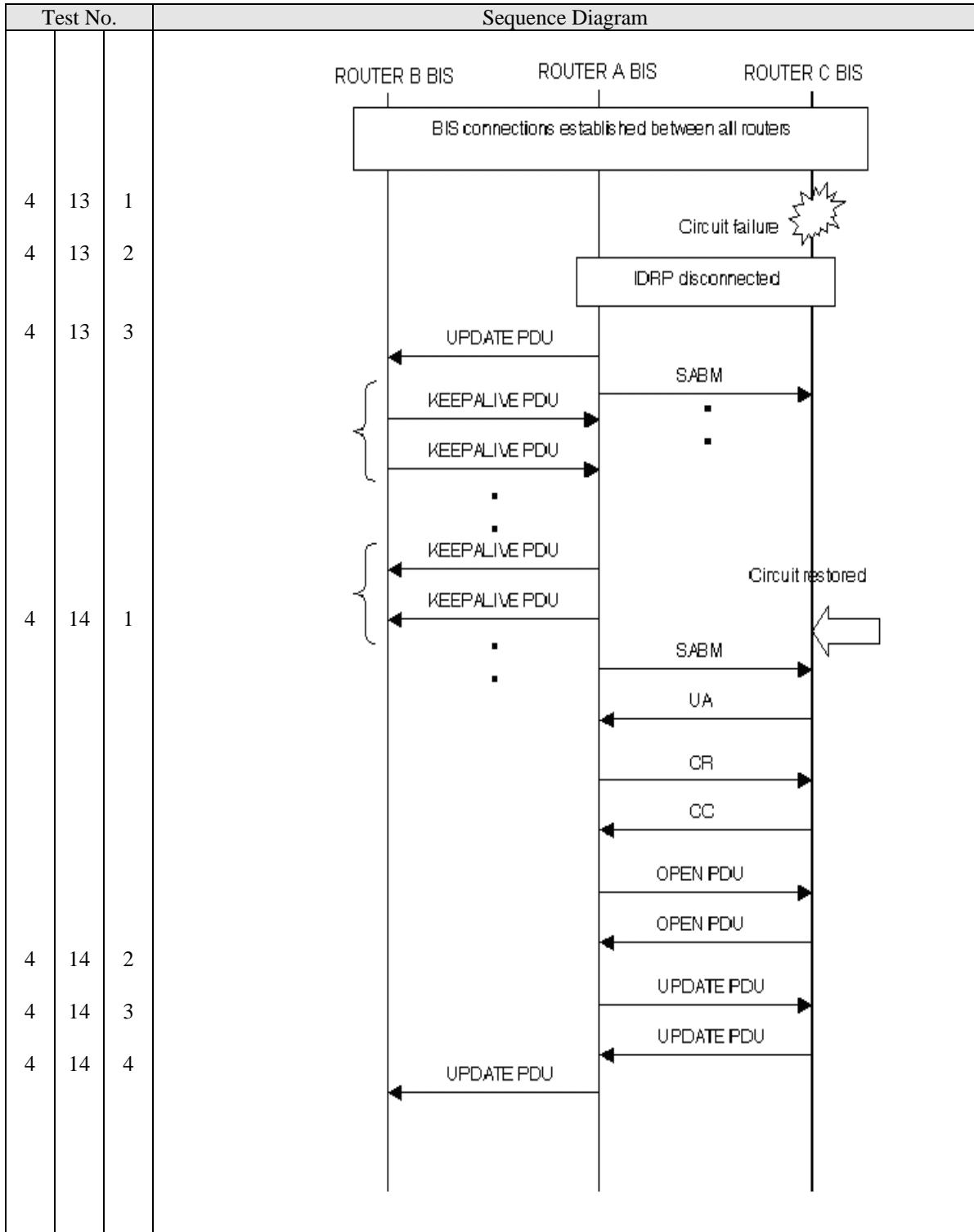

Figure 24 Sequence: Failure and recovery of ROUTER C-ROUTER A circuit

Table 15 Router Failure and Recovery Test Procedure

4. ATN Router Tests		Test Item	Procedure	Result	Date/Time
Failure and recovery of ROUTER C	Failure of ROUTER C	4-15-1	Simulate failure and recovery of ROUTER C by rebooting the router. At failure: <ul style="list-style-type: none"> • At ROUTER A, check that routing information for ROUTER C is deleted. • At ROUTER B, check that routing information for ROUTER C is deleted. 	OK / NG	/ /
	Recovery of ROUTER C	4-15-2	Check that the ROUTER C-ROUTER A router connection is automatically re-established after ROUTER C recovers. After recovery: <ul style="list-style-type: none"> • At ROUTER A, check that routing information for ROUTER C is added. • At ROUTER B, check that routing information for ROUTER C is added. 	OK / NG	/ /
Failure and recovery of ROUTER A	Failure of ROUTER A	4-16-1	Simulate failure and recovery of ROUTER A by forcing failover. At failure: <ul style="list-style-type: none"> • At ROUTER B, check that routing information for ROUTER A and ROUTER C are deleted • At ROUTER C, check that routing information for ROUTER A and ROUTER B are deleted. 	OK / NG	/ /

4. ATN Router Tests		Test Item	Procedure	Result	Date/Time
	Recovery of ROUTER A	4-16-2	<p>Check that the ROUTER C-ROUTER A and ROUTER A-ROUTER B router connections are automatically re-established after ROUTER A recovers.</p> <p>After recovery:</p> <ul style="list-style-type: none"> • At ROUTER A, check that routing information is added for ROUTER C and ROUTER B. • At ROUTER B, check that routing information for ROUTER C and ROUTER A are added. • At ROUTER C, check that routing information for ROUTER A and ROUTER B are added. 	OK / NG	/ /
Failure and recovery of ROUTER B	Failure of ROUTER B	4-17-1	<p>Simulate failure and recovery of ROUTER B by rebooting the router.</p> <p>At failure:</p> <ul style="list-style-type: none"> • At ROUTER A, check that routing information for ROUTER B is deleted. • At ROUTER C, check that routing information for ROUTER B is deleted. 	OK / NG	/ /
	Recovery of ROUTER B	4-17-2	<p>Check that the ROUTER A-ROUTER B router connection is automatically re-established after ROUTER B recovers.</p> <p>After recovery:</p> <ul style="list-style-type: none"> • At ROUTER A, check that routing information for ROUTER B is added. • At ROUTER C, check that routing information for ROUTER B is added. • At ROUTER B, check that routing information for ROUTER A and ROUTER C are added. 	OK / NG	/ /

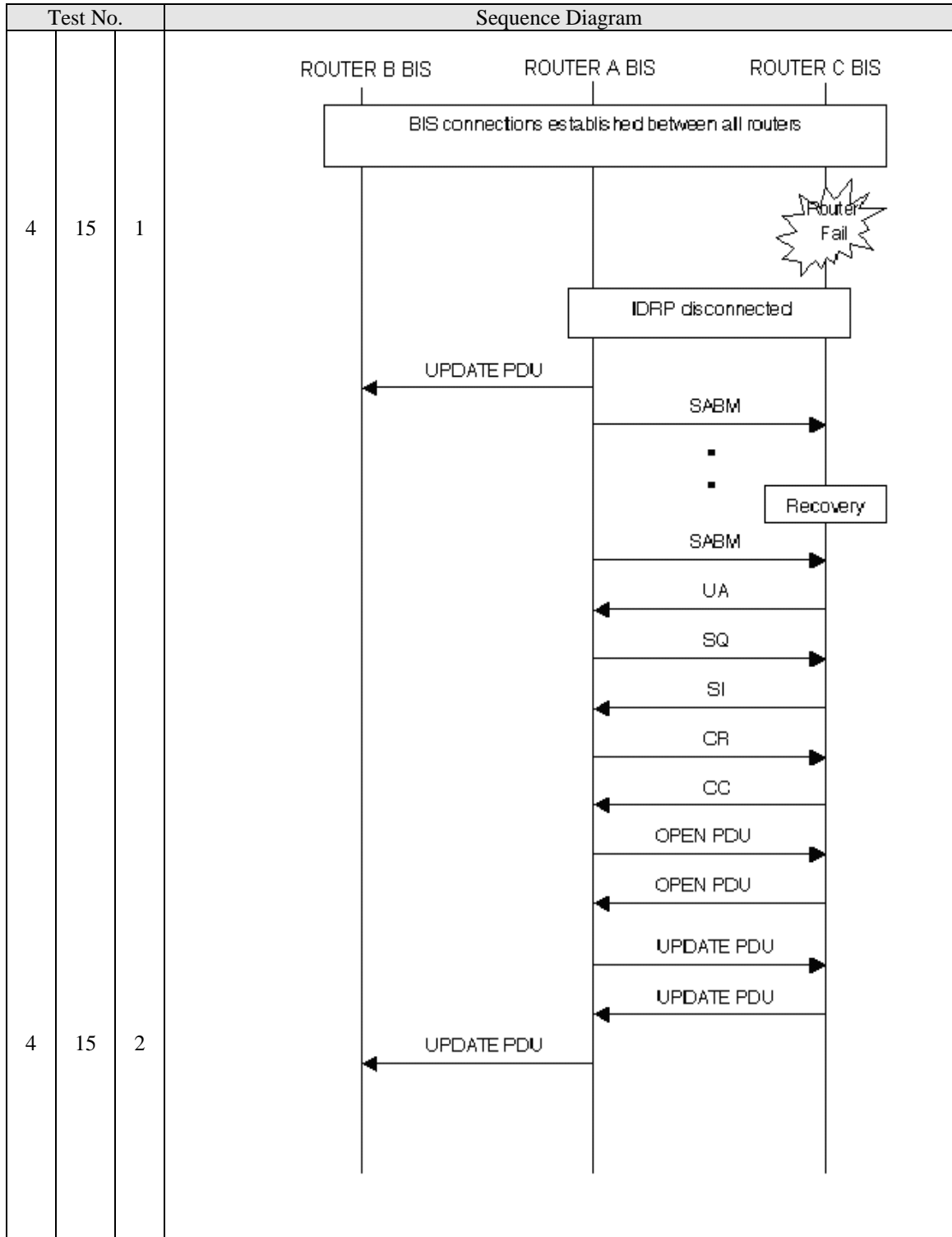

Figure 25 Sequence: Failure and Recovery of ROUTER C

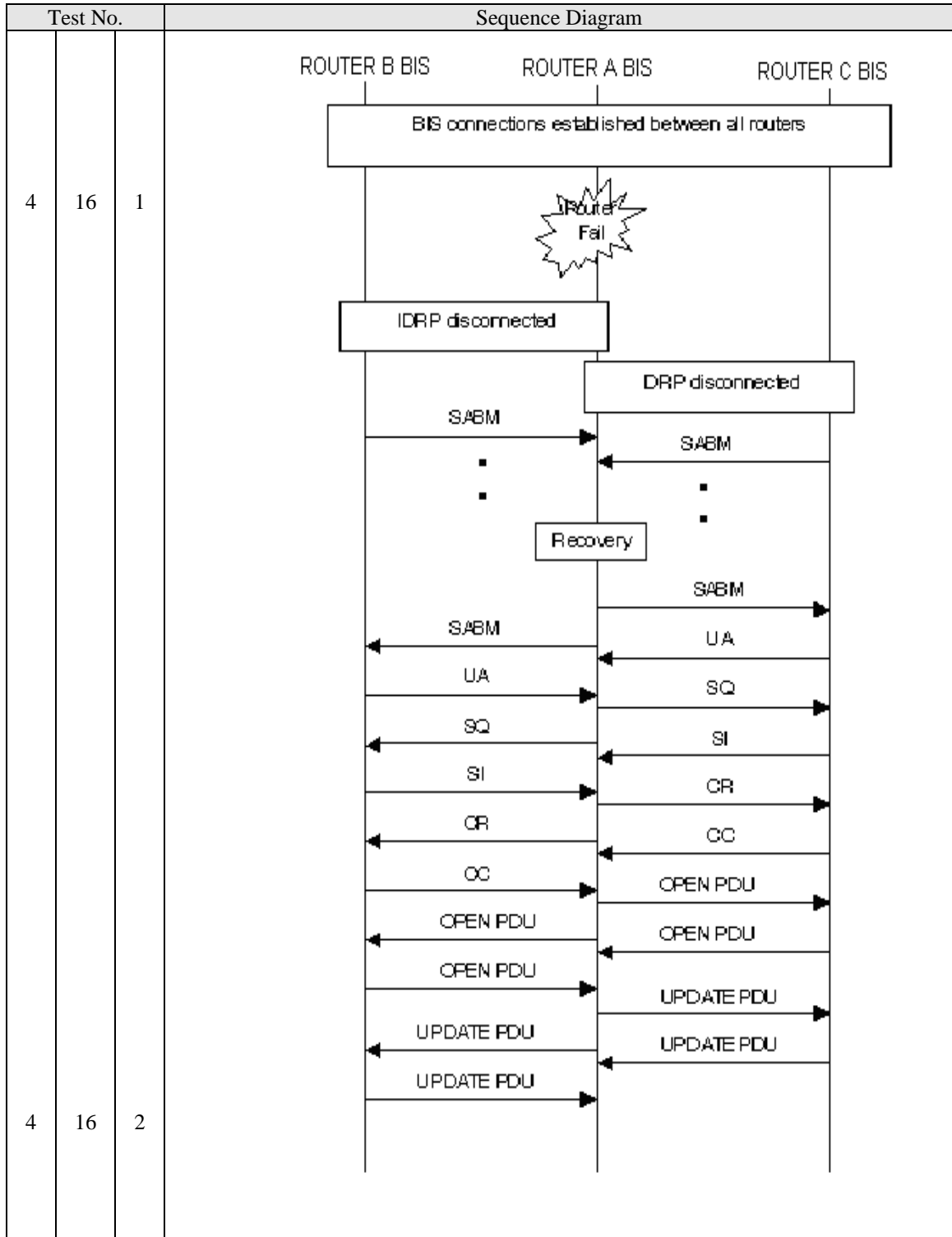

Figure 26 Sequence: Failure and Recovery of ROUTER A

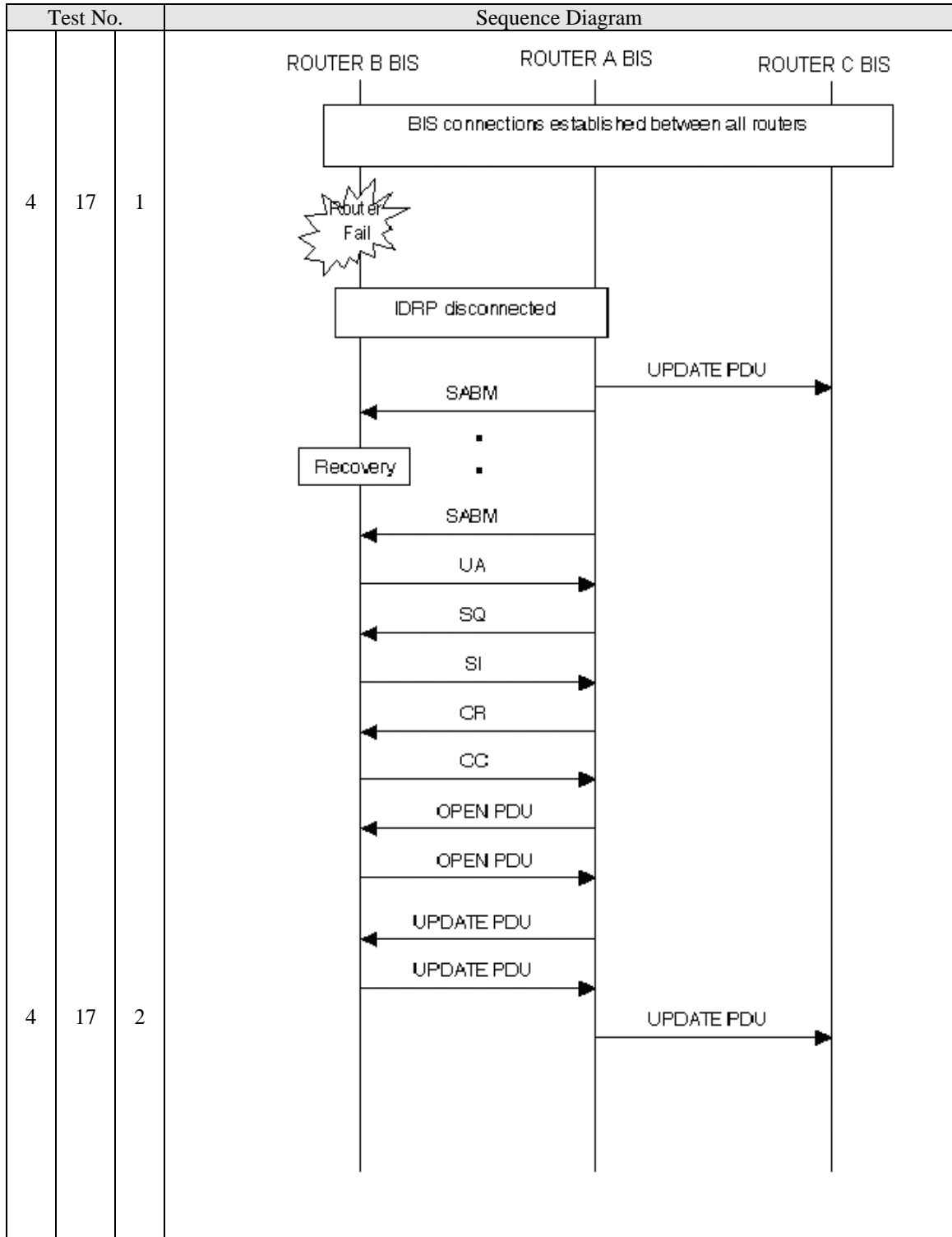

Figure 27 Sequence: Failure and Recovery of ROUTER B

Table 16 End-to-End CLNP Echo Test Procedure

4. ATN Router Tests		Test Item	Procedure	Result	Date/Time
End-to-End CLNP Echo Test between end systems in ROUTER C domain and ROUTER B domain	ERQ transmission	4-18-1	Send ERQ PDU from ES in ROUTER C domain to ES in ROUTER B domain. Confirm receipt of ERQ PDU at ES in ROUTER B domain.	OK / NG	/ /
	ERP transmission	4-18-2	Send ERP PDU from ES in ROUTER B domain to ES in ROUTER C domain. Confirm receipt of ERP PDU at ES in ROUTER C domain.	OK / NG	/ /
	Continuous ERQ/ERP transmission	4-18-3	Repeat 4-18-1 to 4-18-2 ten times to confirm that there is no problem with ERQ/ERP transmission and relay through the ROUTER A.	OK / NG	/ /
	ERQ transmission	4-18-4	Send ERQ PDU from ES in ROUTER B domain to ES in ROUTER C domain. Confirm receipt of ERQ PDU at ES in ROUTER C domain.	OK / NG	/ /
	ERP transmission	4-18-5	Send ERP PDU from ES in ROUTER B domain to ES in ROUTER C domain. Confirm receipt of ERP PDU at ES in ROUTER C domain.	OK / NG	/ /
	Continuous ERQ/ERP transmission	4-18-6	Repeat 4-18-4 to 4-18-6 ten times to confirm that there is no problem with ERQ/ERP transmission and relay through the ROUTER A.	OK / NG	/ /

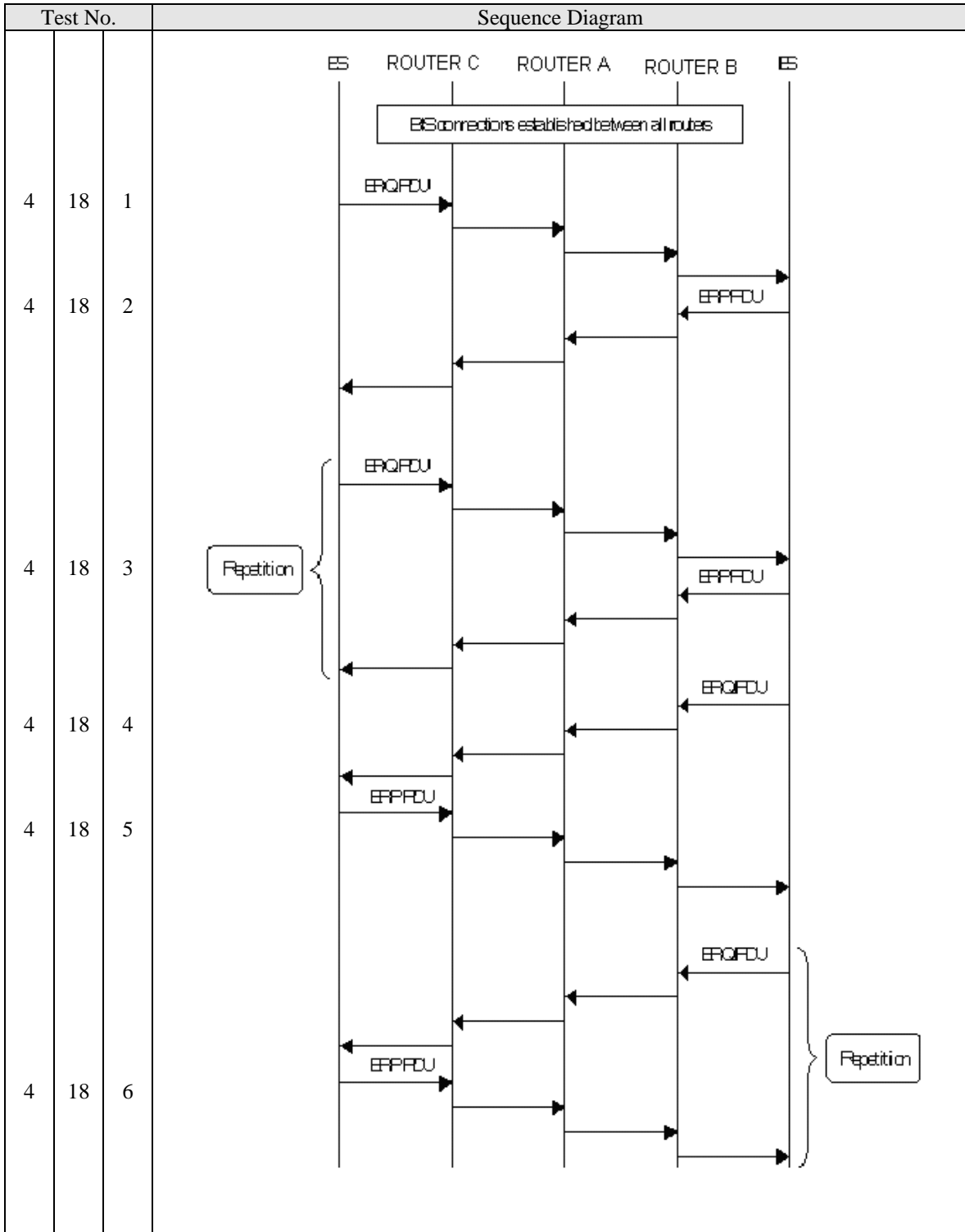

Figure 28 Sequence: End-to-End CLNP Echo Tests

6.5. Test Case 5: ATN Router Network Test

a) Objective

Technical trial to verify multiple router addition/deletion, carrier medium failure/restoration and router failure/recovery with routers connected in three-domain configurations i.e. AMHSLAND1, AMHSLAND2 and AMHSLAND3. The test will also verify routing table updates and automatic re-route. The test configurations are as shown below.

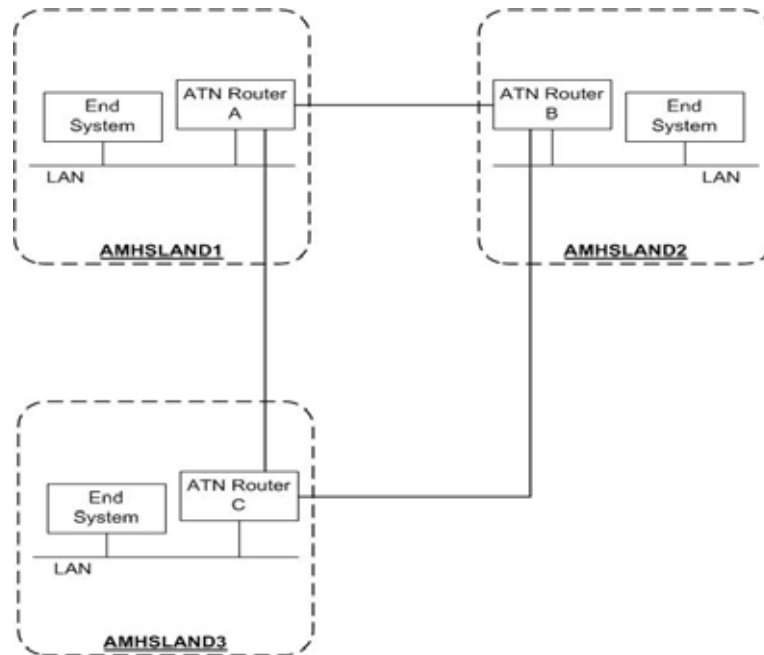

Figure 29 Test Configuration: Routers connected in three-domain configuration

b) Test Overview**(i) Router connected in three-domain configurations*****ROUTER CONNECTION AND ECHO REQUEST (TABLE 17)***

- 5-1: Router connection of ROUTER A to ROUTER B (ROUTER A-ROUTER C and ROUTER B-ROUTER C established).
5-2: Echo test between all routers.

ROUTER DISCONNECTION AND RE-ACTIVATION (TABLE 18)

- 5-3, 5-4: Manual router disconnection at ROUTER A of ROUTER A-ROUTER B route and re-activation.
5-5, 5-6: Manual router disconnection at ROUTER B of ROUTER B-ROUTER C route and re-activation.
5-7, 5-8: Manual router disconnection at ROUTER C of ROUTER C-ROUTER A route and re-activation.

COMMUNICATION CIRCUIT FAILURE AND RECOVERY (TABLE 19)

- 5-9, 5-10: Failure and recovery of ROUTER A-ROUTER B circuit.
5-11, 5-12: Failure and recovery of ROUTER B-ROUTER C circuit.
5-13, 5-14: Failure and recovery of ROUTER C-ROUTER A circuit.

ROUTER FAILURE AND RECOVERY (TABLE 20)

- 5-15: Failure and recovery of ROUTER A.
5-16: Failure and recovery of ROUTER B.
5-17: Failure and recovery of ROUTER C.

ROUTER CONNECTION AND ECHO REQUEST (TABLE 21)

- 5-18: Echo test between all routers.

Table 17 Router Connection and Echo Test Procedure: Routers A, B, C

5. ATN Router Network Test		Test Item	Procedure	Result	Date/Time
Router connection of ROUTER A to ROUTER B	Data link establishment between ROUTER A and ROUTER B	5-1-1	With VC and IDRP connections established between ROUTER A and ROUTER C and also ROUTER B and ROUTER C, initiate the router connection between ROUTER A and ROUTER B. Check and confirm data link and VC are established between ROUTER A and ROUTER B.	OK / NG	/ /
	IDRP connection establishment between ROUTER A and ROUTER B	5-1-2	After VC establishment, check and confirm IDRP connection established between ROUTER A and ROUTER B by exchange of OPEN PDUs.	OK / NG	/ /
	UPDATE PDU transmission from ROUTER A to ROUTER B	5-1-3	After IDRP connection established, confirm ROUTER A sends UPDATE PDUs to ROUTER B. At ROUTER B, after receiving UPDATE PDUs from ROUTER A, check that route information on ROUTER A via one direct hop is added.	OK / NG	/ /
	UPDATE PDU transmission from ROUTER B to ROUTER A	5-1-4	After IDRP connection established, confirm ROUTER B sends UPDATE PDUs to ROUTER A. At ROUTER A, after receiving UPDATE PDUs from ROUTER B, check that route information on ROUTER B via one direct hop is added.	OK / NG	/ /
CLNP Echo Test between routers	ERQ transmission	5-2-1	Send ERQ PDU from ROUTER A to each of the other 2 routers (B, C). Confirm receipt of ERP PDU from each of the 2 routers.	OK / NG	/ /
	ERQ transmission	5-2-2	Send ERQ PDU from ROUTER B to each of the other 2 routers (A, C). Confirm receipt of ERP PDU from each of the 2 routers.	OK / NG	/ /
	ERQ transmission	5-2-3	Send ERQ PDU from ROUTER C to each of the other 2 routers (A, B). Confirm receipt of ERP PDU from each of the 2 routers.	OK / NG	/ /

Table 18 Router Disconnection and Re-activation Test Procedure: Routers A, B, C

5. ATN Router Network Test		Test Item	Procedure	Result	Date/Time
Manual router disconnection at ROUTER A of ROUTER A-ROUTER B route	CEASE PDU transmission from ROUTER A	5-3-1	At ROUTER A, manually close the router connection to ROUTER B. Confirm ROUTER A sends a CEASE PDU to ROUTER B.	OK / NG	/ /
	CEASE PDU transmission from ROUTER B and route update	5-3-2	At ROUTER B, confirm receipt of CEASE PDU from ROUTER A. Confirm ROUTER B sends a CEASE PDU to ROUTER A and that route to ROUTER A is now via ROUTER C.	OK / NG	/ /
	Route update at ROUTER A	5-3-3	At ROUTER A, confirm receipt of CEASE PDU from ROUTER B, and that route to ROUTER B is now via ROUTER C.	OK / NG	/ /
	VC disconnection between ROUTER A and ROUTER B	5-3-4	Confirm that the VC between ROUTER A and ROUTER B is closed normally.	OK / NG	/ /
	ERQ transmission	5-3-5	Send ERQ PDU from ROUTER A to ROUTER B. Confirm receipt of ERP PDU from ROUTER B.	OK / NG	/ /
	ERQ transmission	5-3-6	Send ERQ PDU from ROUTER B to ROUTER A. Confirm receipt of ERP PDU from ROUTER A.	OK / NG	/ /
Route re-activation from ROUTER A	Router connection re-activation from ROUTER A	5-4-1	At ROUTER A, manually initiate router connection to ROUTER B (VC call: caller, OPEN PDU: send). Confirm the X.25 VC and IDRP connection are established.	OK / NG	/ /
	Routing table entries for ROUTER A	5-4-2	Following the exchange of UPDATE PDUs, verify at ROUTER A that route information for ROUTER B is updated, and that the route to ROUTER B is one direct hop.	OK / NG	/ /
	Routing table entries for ROUTER B	5-4-3	Following the exchange of UPDATE PDUs, verify at ROUTER B that route information for ROUTER A is updated, and that the route to ROUTER A is one direct hop.	OK / NG	/ /

5. ATN Router Network Test		Test Item	Procedure	Result	Date/Time
Manual router disconnection at ROUTER B of ROUTER B-ROUTER C route	CEASE PDU transmission from ROUTER B	5-5-1	At ROUTER B, manually close the router connection to ROUTER C. Confirm ROUTER B sends a CEASE PDU to ROUTER C.	OK / NG	/ /
	CEASE PDU transmission from ROUTER C and route update	5-5-2	At ROUTER C, confirm receipt of CEASE PDU from ROUTER B. Confirm ROUTER C sends a CEASE PDU to ROUTER B and that route to ROUTER B is now via ROUTER A.	OK / NG	/ /
	Route update at ROUTER B	5-5-3	At ROUTER B, confirm receipt of CEASE PDU from ROUTER C, and that route to ROUTER C is now via ROUTER A.	OK / NG	/ /
	VC disconnection between ROUTER B and ROUTER C	5-5-4	Confirm that the VC between ROUTER B and ROUTER C is closed normally.	OK / NG	/ /
	ERQ transmission	5-5-5	Send ERQ PDU from ROUTER B to ROUTER C. Confirm receipt of ERP PDU from ROUTER C.	OK / NG	/ /
	ERQ transmission	5-5-6	Send ERQ PDU from ROUTER C to ROUTER B. Confirm receipt of ERP PDU from ROUTER B.	OK / NG	/ /
Route re-activation from ROUTER B	Router connection re-activation from ROUTER B	5-6-1	At ROUTER B, manually initiate router connection to ROUTER C (VC call: caller, OPEN PDU: send). Confirm the X.25 VC and IDR P connection are established.	OK / NG	/ /
	Routing table entries for ROUTER B	5-6-2	Following the exchange of UPDATE PDUs, verify at ROUTER B that route information for ROUTER C is updated, and that the route to ROUTER C is one direct hop.	OK / NG	/ /
	Routing table entries for ROUTER C	5-6-3	Following the exchange of UPDATE PDUs, verify at ROUTER C that route information for ROUTER B is updated, and that the route to ROUTER B is one direct hop.	OK / NG	/ /

5. ATN Router Network Test		Test Item	Procedure	Result	Date/Time
Manual router disconnection at ROUTER C of ROUTER C-ROUTER A route	CEASE PDU transmission from ROUTER C	5-7-1	At ROUTER C, manually close the router connection to ROUTER A. Confirm ROUTER C sends a CEASE PDU to ROUTER A.	OK / NG	/ /
	CEASE PDU transmission from ROUTER A and route update	5-7-2	At ROUTER A, confirm receipt of CEASE PDU from ROUTER C. Confirm ROUTER A sends a CEASE PDU to ROUTER C and that route to ROUTER C is now via ROUTER B.	OK / NG	/ /
	Route update at ROUTER C	5-7-3	At ROUTER C, confirm receipt of CEASE PDU from ROUTER A, and that route to ROUTER A is now via ROUTER B.	OK / NG	/ /
	VC disconnection between ROUTER C and ROUTER A	5-7-4	Confirm that the VC between ROUTER C and ROUTER A is closed normally.	OK / NG	/ /
	ERQ transmission	5-7-5	Send ERQ PDU from ROUTER A to ROUTER C. Confirm receipt of ERP PDU from ROUTER C.	OK / NG	/ /
	ERQ transmission	5-7-6	Send ERQ PDU from ROUTER C to ROUTER A. Confirm receipt of ERP PDU from ROUTER A.	OK / NG	/ /
Route re-activation from ROUTER C	Router connection re-activation from ROUTER C	5-8-1	At ROUTER C, manually initiate router connection to ROUTER A (VC call: caller, OPEN PDU: send). Confirm the X.25 VC and IDRIP connection are established.	OK / NG	/ /
	Routing table entries for ROUTER C	5-8-2	Following the exchange of UPDATE PDUs, verify at ROUTER C that route information for ROUTER A is updated, and that the route to ROUTER A is one direct hop.	OK / NG	/ /
	Routing table entries for ROUTER A	5-8-3	Following the exchange of UPDATE PDUs, verify at ROUTER A that route information for ROUTER C is updated, and that the route to ROUTER C is one direct hop.	OK / NG	/ /

Sequence diagram to be inserted

Table 19 Communication Circuit Failure and Recovery Test Procedure: Routers A, B, C

5. ATN Router Network Test		Test Item	Procedure	Result	Date/Time
Carrier media failure of ROUTER A-ROUTER B circuit and route deletion	Data link and VC disconnection	5-9-1	Simulate carrier medium failure between ROUTER A and ROUTER B by disconnecting WAN cable from ROUTER A. Check and confirm data link and VC are disconnected between ROUTER A and ROUTER B.	OK / NG	/ /
	IDRP disconnection and route update	5-9-2	Check and confirm that IDRP connection between ROUTER A and ROUTER B is closed. At ROUTER A, check that route information for ROUTER B via one direct hop is deleted. At ROUTER B, check that route information for ROUTER A via one direct hop is deleted.	OK / NG	/ /
	ERQ transmission	5-9-3	Send ERQ PDU from ROUTER A to each of the other 2 routers (B, C). Confirm receipt of ERP PDU from each of the 2 routers.	OK / NG	/ /
	ERQ transmission	5-9-4	Send ERQ PDU from ROUTER B to each of the other 2 routers (A, C). Confirm receipt of ERP PDU from each of the 2 routers.	OK / NG	/ /
Carrier media restoration of ROUTER A-ROUTER B circuit and route addition	Data link, VC, and router connection re-establishment	5-10-1	Restore the ROUTER A-ROUTER B router connection. Confirm router connection is re-established between ROUTER A and ROUTER B.	OK / NG	/ /
	Routing table entries for ROUTER A	5-10-2	Following the exchange of UPDATE PDUs, verify at ROUTER A that route information for ROUTER B and ROUTER C exists, and that the route to ROUTER B is one direct hop.	OK / NG	/ /
	Routing table entries for ROUTER B	5-10-3	Following the exchange of UPDATE PDUs, verify at ROUTER B that route information for ROUTER A and ROUTER C exists, and that the route to ROUTER A is one direct hop.	OK / NG	/ /
Carrier media failure of ROUTER B-ROUTER C circuit	Data link and VC disconnection	5-11-1	Simulate carrier medium failure between ROUTER B and ROUTER C by disconnecting WAN cable from ROUTER B. Check and confirm data link and VC are disconnected between ROUTER B and ROUTER C.	OK / NG	/ /

5. ATN Router Network Test		Test Item	Procedure	Result	Date/Time
	IDRP disconnection and route update	5-11-2	Check and confirm that IDRP connection between ROUTER B and ROUTER C is closed. At ROUTER B, check that route information for ROUTER C via one direct hop is deleted. At ROUTER C, check that route information for ROUTER B via one direct hop is deleted.	OK / NG	/ /
	ERQ transmission	5-11-3	Send ERQ PDU from ROUTER B to each of the other 2 routers (A, C). Confirm receipt of ERP PDU from each of the 2 routers.	OK / NG	/ /
	ERQ transmission	5-11-4	Send ERQ PDU from ROUTER C to each of the other 2 routers (A, B). Confirm receipt of ERP PDU from each of the 2 routers.	OK / NG	/ /
Carrier media restoration of ROUTER B-ROUTER C circuit and route addition	Data link, VC, and router connection re-establishment	5-12-1	Restore the ROUTER B-ROUTER C router connection. Confirm router connection is re-established between ROUTER B and ROUTER C.	OK / NG	/ /
	Routing table entries for ROUTER A	5-12-2	Following the exchange of UPDATE PDUs, verify at ROUTER B that route information for ROUTER A and ROUTER C exists, and that the route to ROUTER C is one direct hop.	OK / NG	/ /
	Routing table entries for ROUTER B	5-12-3	Following the exchange of UPDATE PDUs, verify at ROUTER C that route information for ROUTER A and ROUTER B exists, and that the route to ROUTER B is one direct hop.	OK / NG	/ /
Carrier media failure of ROUTER C-ROUTER A circuit	Data link and VC disconnection	5-13-1	Simulate carrier medium failure between ROUTER C and ROUTER A by disconnecting WAN cable from ROUTER C. Check and confirm data link and VC are disconnected between ROUTER C and ROUTER A.	OK / NG	/ /
	IDRP disconnection and route update	5-13-2	Check and confirm that IDRP connection between ROUTER C and ROUTER A is closed. At ROUTER C, check that route information for ROUTER A via one direct hop is deleted. At ROUTER A, check that route information for ROUTER C via one direct hop is deleted.	OK / NG	/ /

5. ATN Router Network Test		Test Item	Procedure	Result	Date/Time
	ERQ transmission	5-13-3	Send ERQ PDU from ROUTER C to each of the other 2 routers (B, A). Confirm receipt of ERP PDU from each of the 2 routers.	OK / NG	/ /
	ERQ transmission	5-13-4	Send ERQ PDU from ROUTER A to each of the other 2 routers (B, C). Confirm receipt of ERP PDU from each of the 2 routers.	OK / NG	/ /
Carrier media restoration of ROUTER C-ROUTER A circuit and route addition	Data link, VC, and router connection re-establishment	5-14-1	Restore the ROUTER C-ROUTER A router connection. Confirm router connection is re-established between ROUTER C and ROUTER A.	OK / NG	/ /
	Routing table entries for ROUTER A	5-14-2	Following the exchange of UPDATE PDUs, verify at ROUTER C that route information for ROUTER B and ROUTER A exists, and that the route to ROUTER A is one direct hop.	OK / NG	/ /
	Routing table entries for ROUTER B	5-14-3	Following the exchange of UPDATE PDUs, verify at ROUTER A that route information for ROUTER B and ROUTER C exists, and that the route to ROUTER C is one direct hop.	OK / NG	/ /

Sequence diagram to be inserted

Table 20 Router Failure and Recovery Test Procedure: Routers A, B, C

5. ATN Router Network Test		Test Item	Procedure	Result	Date/Time
Failure and recovery of ROUTER A	Failure of ROUTER A	5-15-1	<p>Simulate failure and recovery of ROUTER A by rebooting the router.</p> <p>At failure:</p> <ul style="list-style-type: none"> • At ROUTER B, verify that routing information for ROUTER A is deleted, but that routing information for ROUTER C remains. • At ROUTER C, verify that routing information for ROUTER A is deleted, but that routing information for ROUTER B remains. 	OK / NG	/ /
	Recovery of ROUTER A	5-15-2	<p>Check that the ROUTER A-ROUTER B and ROUTER A-ROUTER C router connections are automatically re-established after ROUTER A recovers.</p> <p>After recovery:</p> <ul style="list-style-type: none"> • At ROUTER A, check that routing information is added for ROUTER B and ROUTER C. • At ROUTER B, check that routing information for ROUTER A is added. • At ROUTER C, check that routing information for ROUTER A is added. 	OK / NG	/ /
Failure and recovery of ROUTER B	Failure of ROUTER B	5-16-1	<p>Simulate failure and recovery of ROUTER B by rebooting the router.</p> <p>At failure:</p> <ul style="list-style-type: none"> • At ROUTER A, verify that routing information for ROUTER B is deleted, but that routing information for ROUTER C remains. • At ROUTER C, verify that routing information for ROUTER B is deleted, but that routing information for ROUTER A remains. 	OK / NG	/ /

5. ATN Router Network Test		Test Item	Procedure	Result	Date/Time
	Recovery of ROUTER B	5-16-2	<p>Check that the ROUTER A-ROUTER B and ROUTER B-ROUTER C router connections are automatically re-established after ROUTER B recovers.</p> <p>After recovery:</p> <ul style="list-style-type: none"> • At ROUTER B, check that routing information is added for ROUTER A and ROUTER C. • At ROUTER A, check that routing information for ROUTER B is added. • At ROUTER C, check that routing information for ROUTER B is added.. 	OK / NG	/ /
Failure and recovery of ROUTER C	Failure of ROUTER C	5-17-1	<p>Simulate failure and recovery of ROUTER C by rebooting the router.</p> <p>At failure:</p> <ul style="list-style-type: none"> • At ROUTER A, verify that routing information for ROUTER C is deleted, but that routing information for ROUTER B remains. • At ROUTER B, verify that routing information for ROUTER C is deleted, but that routing information for ROUTER A remains. 	OK / NG	/ /
	Recovery of ROUTER C	5-17-2	<p>Check that the ROUTER A-ROUTER C and ROUTER C-ROUTER B router connections are automatically re-established after ROUTER C recovers.</p> <p>After recovery:</p> <ul style="list-style-type: none"> • At ROUTER C, check that routing information is added for ROUTER A and ROUTER B. • At ROUTER A, check that routing information for ROUTER C is added. • At ROUTER B, check that routing information for ROUTER C is added. 	OK / NG	/ /

Sequence diagram to be inserted

Table 21 Echo Test Procedure: Routers A, B, C

5. ATN Router Network Test		Test Item	Procedure	Result	Date/Time
CLNP Echo Test between routers	ERQ transmission	5-18-1	Send ERQ PDU from ROUTER A to each of the other 2 routers (B, C). Confirm receipt of ERP PDU from each of the 2 routers.	OK / NG	/ /
	ERQ transmission	5-18-2	Send ERQ PDU from ROUTER B to each of the other 2 routers (A, C). Confirm receipt of ERP PDU from each of the 3 routers.	OK / NG	/ /
	ERQ transmission	5-18-3	Send ERQ PDU from ROUTER C to each of the other 2 routers (A, B). Confirm receipt of ERP PDU from each of the 2 routers.	OK / NG	/ /

Sequence diagram to be inserted

6.6. Test Case 6: ATN Router Network Test

a) Objective

Technical trial to verify multiple router addition/deletion, carrier medium failure/restoration and router failure/recovery with routers connected in four-domain configurations i.e. AMHSLAND1, AMHSLAND2, AMHSLAND3 and AMHSLAND4. The test will also verify routing table updates and automatic re-route. The test configurations are as shown below.

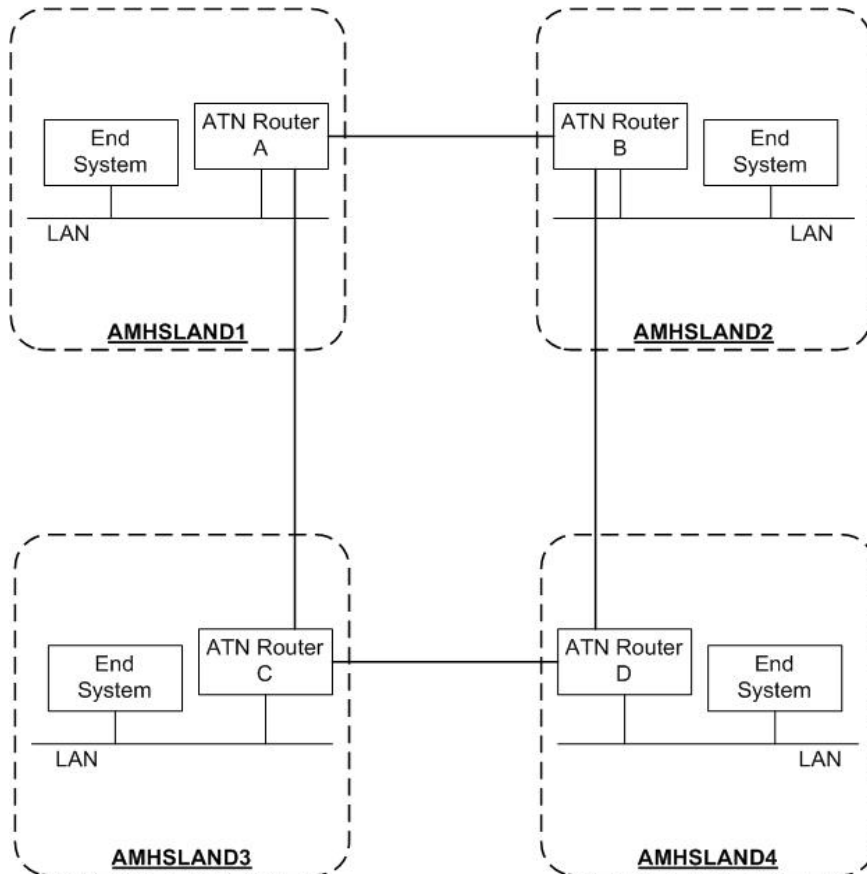

Figure 30 Test Configuration: Routers connected in three-domain configuration

b) Test Overview**(i) Router connected in four-domain configurations*****ROUTER CONNECTION AND ECHO REQUEST (TABLE 22)***

- 6-1: Router connection of ROUTER A to ROUTER B (ROUTER A-ROUTER C and ROUTER B-ROUTER D established).
- 6-2: Router connection of ROUTER C to ROUTER D.
- 6-3: Echo test between all routers.

ROUTER DISCONNECTION AND RE-ACTIVATION (TABLE 23)

- 6-4, 6-5: Manual router disconnection at ROUTER A of ROUTER A-ROUTER B route and re-activation.
- 6-6, 6-7: Manual router disconnection at ROUTER B of ROUTER B-ROUTER D route and re-activation.
- 6-8, 6-9: Manual router disconnection at ROUTER D of ROUTER D-ROUTER C route and re-activation.
- 6-10, 6-11: Manual router disconnection at ROUTER C of ROUTER C-ROUTER A route and re-activation.

COMMUNICATION CIRCUIT FAILURE AND RECOVERY (TABLE 24)

- 6-12, 6-13: Failure and recovery of ROUTER A-ROUTER B circuit.
- 6-14, 6-15: Failure and recovery of ROUTER B-ROUTER D circuit.
- 6-16, 6-17: Failure and recovery of ROUTER D-ROUTER C circuit.
- 6-18, 6-19: Failure and recovery of ROUTER C-ROUTER A circuit.

ROUTER FAILURE AND RECOVERY (TABLE 25)

- 6-20: Failure and recovery of ROUTER A.
- 6-21: Failure and recovery of ROUTER B.
- 6-22: Failure and recovery of ROUTER C.
- 6-23: Failure and recovery of ROUTER D.

ROUTER CONNECTION AND ECHO REQUEST (TABLE 26)

- 6-24: Echo test between all routers.

Table 22 Router Connection, Echo Test: Routers A, B, C, D

6. ATN Router Network Test		Test Item	Procedure	Result	Date/Time
Router connection of ROUTER A to ROUTER B	Data link establishment between ROUTER A and ROUTER B	6-1-1	With VC and IDRP connections established between ROUTER A and ROUTER C and also ROUTER B and ROUTER D, initiate the router connection between ROUTER A and ROUTER B. Check and confirm data link and VC are established between ROUTER A and ROUTER B.	OK / NG	/ /
	IDRP connection establishment between ROUTER A and ROUTER B	6-1-2	After VC establishment, check and confirm IDRP connection established between ROUTER A and ROUTER B by exchange of OPEN PDUs.	OK / NG	/ /
	UPDATE PDU transmission from ROUTER A to ROUTER B	6-1-3	After IDRP connection established, confirm ROUTER A sends UPDATE PDUs to ROUTER B. At ROUTER B, after receiving UPDATE PDUs from ROUTER A, check that route information on ROUTER A and ROUTER C are added.	OK / NG	/ /
	UPDATE PDU transmission from ROUTER B to ROUTER A	6-1-4	After IDRP connection established, confirm ROUTER B sends UPDATE PDUs to ROUTER A. At ROUTER A, after receiving UPDATE PDUs from ROUTER B, check that route information on ROUTER B and ROUTER D are added.	OK / NG	/ /
	UPDATE PDU transmission from ROUTER A to ROUTER C	6-1-5	At ROUTER A, after receiving UPDATE PDUs from ROUTER B, confirm ROUTER A sends an UPDATE PDU to ROUTER C. At ROUTER C, confirm that UPDATE PDU is received, and that route information of ROUTER B and ROUTER D is added.	OK / NG	/ /
	UPDATE PDU transmission from ROUTER B to ROUTER D	6-1-6	At ROUTER B, after receiving UPDATE PDUs from ROUTER A, confirm ROUTER B sends an UPDATE PDU to ROUTER D. At ROUTER D, confirm that UPDATE PDU is received, and that route information of ROUTER A and ROUTER C is added.	OK / NG	/ /

6. ATN Router Network Test		Test Item	Procedure	Result	Date/Time
Router connection of ROUTER C to ROUTER D	Data link establishment between ROUTER C and ROUTER D	6-2-1	Initiate the router connection between ROUTER C and ROUTER D. Check and confirm data link and VC are established between ROUTER C and ROUTER D.	OK / NG	/ /
	IDRP connection establishment between ROUTER C and ROUTER D	6-2-2	After VC establishment, check and confirm IDRP connection established between ROUTER C and ROUTER D by exchange of OPEN PDUs.	OK / NG	/ /
	UPDATE PDU transmission from ROUTER C to ROUTER D	6-2-3	After IDRP connection established, confirm ROUTER C sends UPDATE PDUs to ROUTER D. At ROUTER D, after receiving UPDATE PDUs from ROUTER C, check that appropriate route information for ROUTER A and ROUTER B are present in routing table.	OK / NG	/ /
	UPDATE PDU transmission from ROUTER D to ROUTER C	6-2-4	After IDRP connection established, confirm ROUTER D sends UPDATE PDUs to ROUTER C. At ROUTER C, after receiving UPDATE PDUs from ROUTER D, check that appropriate route information for ROUTER A and ROUTER B are present in routing table.	OK / NG	/ /
	UPDATE PDU transmission from ROUTER C to ROUTER A	6-2-5	At ROUTER C, after receiving UPDATE PDUs from ROUTER D, confirm ROUTER C sends an UPDATE PDU to ROUTER A. At ROUTER A, confirm that UPDATE PDU is received, check that appropriate route information for ROUTER B and ROUTER D are present in the routing table.	OK / NG	/ /
	UPDATE PDU transmission from ROUTER D to ROUTER B	6-2-6	At ROUTER D, after receiving UPDATE PDUs from ROUTER C, confirm ROUTER D sends an UPDATE PDU to ROUTER B. At ROUTER B, confirm that UPDATE PDU is received, check that appropriate route information for ROUTER A and ROUTER C are present in the routing table.	OK / NG	/ /
CLNP Echo Test between routers	ERQ transmission	6-3-1	Send ERQ PDU from ROUTER A to each of the other 3 routers (B, C, D). Confirm receipt of ERP PDU from each of the 3 routers.	OK / NG	/ /

6. ATN Router Network Test		Test Item	Procedure	Result	Date/Time
CLNP Echo Test between routers	ERQ transmission	6-3-1	Send ERQ PDU from ROUTER A to each of the other 3 routers (B, C, D). Confirm receipt of ERP PDU from each of the 3 routers.	OK / NG	/ /
	ERQ transmission	6-3-2	Send ERQ PDU from ROUTER B to each of the other 3 routers (A, C, D). Confirm receipt of ERP PDU from each of the 3 routers.	OK / NG	/ /
	ERQ transmission	6-3-3	Send ERQ PDU from ROUTER C to each of the other 3 routers (A, B, D). Confirm receipt of ERP PDU from each of the 3 routers.	OK / NG	/ /
	ERQ transmission	6-3-4	Send ERQ PDU from ROUTER D to each of the other 3 routers (A, B, C). Confirm receipt of ERP PDU from each of the 3 routers.	OK / NG	/ /

Sequence diagram to be inserted

Table 23 Router Disconnection and Re-activation: Routers A, B, C, D

6. ATN Router Network Test		Test Item	Procedure	Result	Date/Time
Manual router disconnection at ROUTER A of ROUTER A-ROUTER B route	CEASE PDU transmission from ROUTER A	6-4-1	At ROUTER A, manually close the router connection to ROUTER B. Confirm ROUTER A sends a CEASE PDU to ROUTER B.	OK / NG	/ /
	CEASE PDU transmission from ROUTER B and route deletion	6-4-2	At ROUTER B, confirm receipt of CEASE PDU from ROUTER A. Confirm ROUTER B sends a CEASE PDU to ROUTER A. However, confirm that route information for all 3 other routers still exists, and that the route to ROUTER A is through ROUTER D and ROUTER C.	OK / NG	/ /
	ERQ transmission	6-4-3	Send ERQ PDU from ROUTER A to each of the other 3 routers (B, C, D). Confirm receipt of ERP PDU from each of the 3 routers.	OK / NG	/ /
	ERQ transmission	6-4-4	Send ERQ PDU from ROUTER B to each of the other 3 routers (A, C, D). Confirm receipt of ERP PDU from each of the 3 routers.	OK / NG	/ /
Route re-activation from ROUTER A	Router connection re-activation from ROUTER A	6-5-1	At ROUTER A, manually initiate router connection to ROUTER B (VC call: caller, OPEN PDU: send). Confirm the X.25 VC and IDRP connection are established.	OK / NG	/ /
	Routing table entries for ROUTER A	6-5-2	Following the exchange of UPDATE PDUs, verify at ROUTER A that route information for all 3 other routers exists, and that the route to ROUTER B is one direct hop.	OK / NG	/ /
	Routing table entries for ROUTER B	6-5-3	Following the exchange of UPDATE PDUs, verify at ROUTER B that route information for all 3 other routers exists, and that the route to ROUTER A is one direct hop.	OK / NG	/ /
Manual router disconnection at ROUTER B of ROUTER B-ROUTER D route	CEASE PDU transmission from ROUTER B	6-6-1	At ROUTER B, manually close the router connection to ROUTER D. Confirm ROUTER B sends a CEASE PDU to ROUTER D.	OK / NG	/ /
	CEASE PDU transmission from ROUTER D and route deletion	6-6-2	At ROUTER D, confirm receipt of CEASE PDU from ROUTER B. Confirm ROUTER D sends a CEASE PDU to ROUTER B. However, confirm that route information for all 3 other routers still exists, and that the route to ROUTER B is through ROUTER C and ROUTER A.	OK / NG	/ /

6. ATN Router Network Test		Test Item	Procedure	Result	Date/Time
	ERQ transmission	6-6-3	Send ERQ PDU from ROUTER B to each of the other 3 routers (A, C, D). Confirm receipt of ERP PDU from each of the 3 routers.	OK / NG	/ /
	ERQ transmission	6-6-4	Send ERQ PDU from ROUTER D to each of the other 3 routers (A, B, C). Confirm receipt of ERP PDU from each of the 3 routers.	OK / NG	/ /
Route re-activation from ROUTER B	Router connection re-activation from ROUTER B	6-7-1	At ROUTER B, manually initiate router connection to ROUTER D (VC call: caller, OPEN PDU: send). Confirm the X.25 VC and IDRP connection are established.	OK / NG	/ /
	Routing table entries for ROUTER B	6-7-2	Following the exchange of UPDATE PDUs, verify at ROUTER B that route information for all 3 other routers exists, and that the route to ROUTER D is one direct hop.	OK / NG	/ /
	Routing table entries for ROUTER D	6-7-3	Following the exchange of UPDATE PDUs, verify at ROUTER D that route information for all 3 other routers exists, and that the route to ROUTER B is one direct hop.	OK / NG	/ /
Manual router disconnection at ROUTER D of ROUTER D-ROUTER C route	CEASE PDU transmission from ROUTER D	6-8-1	At ROUTER D, manually close the router connection to ROUTER C. Confirm ROUTER D sends a CEASE PDU to ROUTER C.	OK / NG	/ /
	CEASE PDU transmission from ROUTER C and route deletion	6-8-2	At ROUTER C, confirm receipt of CEASE PDU from ROUTER D. Confirm ROUTER C sends a CEASE PDU to ROUTER D. However, confirm that route information for all 3 other routers still exists, and that the route to ROUTER D is through ROUTER A and ROUTER B.	OK / NG	/ /
	ERQ transmission	6-8-3	Send ERQ PDU from ROUTER D to each of the other 3 routers (A, B, C). Confirm receipt of ERP PDU from each of the 3 routers.	OK / NG	/ /
	ERQ transmission	6-8-4	Send ERQ PDU from ROUTER C to each of the other 3 routers (A, B, D). Confirm receipt of ERP PDU from each of the 3 routers.	OK / NG	/ /
Route re-activation from ROUTER D	Router connection re-activation from ROUTER D	6-9-1	At ROUTER D, manually initiate router connection to ROUTER C (VC call: caller, OPEN PDU: send). Confirm the X.25 VC and IDRP connection are established.	OK / NG	/ /
	Routing table entries for ROUTER D	6-9-2	Following the exchange of UPDATE PDUs, verify at ROUTER D that route information for all 3 other routers exists, and that the route to ROUTER C is one direct hop.	OK / NG	/ /

6. ATN Router Network Test		Test Item	Procedure	Result	Date/Time
	Routing table entries for ROUTER C	6-9-3	Following the exchange of UPDATE PDUs, verify at ROUTER C that route information for all 3 other routers exists, and that the route to ROUTER D is one direct hop.	OK / NG	/ /
Manual router disconnection at ROUTER C of ROUTER C-ROUTER A route	CEASE PDU transmission from ROUTER C	6-10-1	At ROUTER C, manually close the router connection to ROUTER A. Confirm ROUTER C sends a CEASE PDU to ROUTER A.	OK / NG	/ /
	CEASE PDU transmission from ROUTER A and route deletion	6-10-2	At ROUTER A, confirm receipt of CEASE PDU from ROUTER C. Confirm ROUTER A sends a CEASE PDU to ROUTER C. However, confirm that route information for all 3 other routers still exists, and that the route to ROUTER C is through ROUTER B and ROUTER D.	OK / NG	/ /
	ERQ transmission	6-10-3	Send ERQ PDU from ROUTER C to each of the other 3 routers (A, B, D). Confirm receipt of ERP PDU from each of the 3 routers.	OK / NG	/ /
	ERQ transmission	6-10-4	Send ERQ PDU from ROUTER A to each of the other 3 routers (B, C, D). Confirm receipt of ERP PDU from each of the 3 routers.	OK / NG	/ /
Route re-activation from ROUTER C	Router connection re-activation from ROUTER C	6-11-1	At ROUTER C, manually initiate router connection to ROUTER A (VC call: caller, OPEN PDU: send). Confirm the X.25 VC and IDRP connection are established.	OK / NG	/ /
	Routing table entries for ROUTER C	6-11-2	Following the exchange of UPDATE PDUs, verify at ROUTER C that route information for all 3 other routers exists, and that the route to ROUTER A is one direct hop.	OK / NG	/ /
	Routing table entries for ROUTER A	6-11-3	Following the exchange of UPDATE PDUs, verify at ROUTER A that route information for all 3 other routers exists, and that the route to ROUTER C is one direct hop.	OK / NG	/ /

Sequence diagram to be inserted

Table 24 Communication Circuit Failure and Recovery Test Procedure: Routers A, B, C, D

6. ATN Router Network Test		Test Item	Procedure	Result	Date/Time
Carrier media failure of ROUTER A-ROUTER B circuit	Data link and VC disconnection	6-12-1	Simulate carrier medium failure between ROUTER A and ROUTER B by disconnecting WAN cable from ROUTER A. Check and confirm data link and VC are disconnected between ROUTER A and ROUTER B.	OK / NG	/ /
	IDRP disconnection and route update	6-12-2	Check and confirm that IDRP connection between ROUTER A and ROUTER B is closed. However, confirm in ROUTER A that route information for all 3 other routers still exists, and that the route to ROUTER B is through ROUTER C and ROUTER D. Also, confirm in ROUTER B that route information for all 3 other routers still exists, and that the route to ROUTER A is through ROUTER D and ROUTER C.	OK / NG	/ /
	ERQ transmission	6-12-3	Send ERQ PDU from ROUTER A to each of the other 3 routers (B, C, D). Confirm receipt of ERP PDU from each of the 3 routers.	OK / NG	/ /
	ERQ transmission	6-12-4	Send ERQ PDU from ROUTER B to each of the other 3 routers (A, C, D). Confirm receipt of ERP PDU from each of the 3 routers.	OK / NG	/ /
Carrier media restoration of ROUTER A-ROUTER B circuit and route addition	Data link, VC, and router connection re-establishment	6-13-1	Restore the ROUTER A-ROUTER B router connection. Confirm router connection is re-established between ROUTER A and ROUTER B.	OK / NG	/ /
	Routing table entries for ROUTER A	6-13-2	Following the exchange of UPDATE PDUs, verify at ROUTER A that route information for all 3 other routers exists, and that the route to ROUTER B is one direct hop.	OK / NG	/ /
	Routing table entries for ROUTER B	6-13-3	Following the exchange of UPDATE PDUs, verify at ROUTER B that route information for all 3 other routers exists, and that the route to ROUTER A is one direct hop.	OK / NG	/ /
Carrier media failure of ROUTER B-ROUTER D circuit	Data link and VC disconnection	6-14-1	Simulate carrier medium failure between ROUTER B and ROUTER D by disconnecting WAN cable from ROUTER B. Check and confirm data link and VC are disconnected between ROUTER B and ROUTER D.	OK / NG	/ /

6. ATN Router Network Test		Test Item	Procedure	Result	Date/Time
	IDRP disconnection and route update	6-14-2	Check and confirm that IDRP connection between ROUTER B and ROUTER D is closed. However, confirm in ROUTER B that route information for all 3 other routers still exists, and that the route to ROUTER D is through ROUTER A and ROUTER C. Also, confirm in ROUTER D that route information for all 3 other routers still exists, and that the route to ROUTER B is through ROUTER C and ROUTER A.	OK / NG	/ /
	ERQ transmission	6-14-3	Send ERQ PDU from ROUTER B to each of the other 3 routers (A, C, D). Confirm receipt of ERP PDU from each of the 3 routers.	OK / NG	/ /
	ERQ transmission	6-14-4	Send ERQ PDU from ROUTER D to each of the other 3 routers (A, B, C). Confirm receipt of ERP PDU from each of the 3 routers.	OK / NG	/ /
Carrier media restoration of ROUTER B-ROUTER D circuit and route addition	Data link, VC, and router connection re-establishment	6-15-1	Restore the ROUTER B-ROUTER D router connection. Confirm router connection is re-established between ROUTER B and ROUTER D.	OK / NG	/ /
	Routing table entries for ROUTER B	6-15-2	Following the exchange of UPDATE PDUs, verify at ROUTER B that route information for all 3 other routers exists, and that the route to ROUTER D is one direct hop.	OK / NG	/ /
	Routing table entries for ROUTER D	6-15-3	Following the exchange of UPDATE PDUs, verify at ROUTER D that route information for all 3 other routers exists, and that the route to ROUTER B is one direct hop.	OK / NG	/ /
Carrier media failure of ROUTER D-ROUTER C circuit	Data link and VC disconnection	6-16-1	Simulate carrier medium failure between ROUTER D and ROUTER C by disconnecting WAN cable from ROUTER D. Check and confirm data link and VC are disconnected between ROUTER D and ROUTER C.	OK / NG	/ /
	IDRP disconnection and route update	6-16-2	Check and confirm that IDRP connection between ROUTER D and ROUTER C is closed. However, confirm in ROUTER D that route information for all 3 other routers still exists, and that the route to ROUTER C is through ROUTER B and ROUTER A. Also, confirm in ROUTER C that route information for all 3 other routers still exists, and that the route to ROUTER D is through ROUTER A and ROUTER B.	OK / NG	/ /

6. ATN Router Network Test		Test Item	Procedure	Result	Date/Time
	ERQ transmission	6-16-3	Send ERQ PDU from ROUTER D to each of the other 3 routers (A, B, C). Confirm receipt of ERP PDU from each of the 3 routers.	OK / NG	/ /
	ERQ transmission	6-16-4	Send ERQ PDU from ROUTER C to each of the other 3 routers (A, B, D). Confirm receipt of ERP PDU from each of the 3 routers.	OK / NG	/ /
Carrier media restoration of ROUTER D-ROUTER C circuit and route addition	Data link, VC, and router connection re-establishment	6-17-1	Restore the ROUTER D-ROUTER C router connection. Confirm router connection is re-established between ROUTER D and ROUTER C.	OK / NG	/ /
	Routing table entries for ROUTER D	6-17-2	Following the exchange of UPDATE PDUs, verify at ROUTER D that route information for all 3 other routers exists, and that the route to ROUTER C is one direct hop.	OK / NG	/ /
	Routing table entries for ROUTER C	6-17-3	Following the exchange of UPDATE PDUs, verify at ROUTER C that route information for all 3 other routers exists, and that the route to ROUTER D is one direct hop.	OK / NG	/ /
Carrier media failure of ROUTER C-ROUTER A circuit	Data link and VC disconnection	6-18-1	Simulate carrier medium failure between ROUTER C and ROUTER A by disconnecting WAN cable from ROUTER C. Check and confirm data link and VC are disconnected between ROUTER C and ROUTER A.	OK / NG	/ /
	IDRP disconnection and route update	6-18-2	Check and confirm that IDRP connection between ROUTER C and ROUTER A is closed. However, confirm in ROUTER C that route information for all 3 other routers still exists, and that the route to ROUTER A is through ROUTER D and ROUTER B. Also, confirm in ROUTER A that route information for all 3 other routers still exists, and that the route to ROUTER C is through ROUTER B and ROUTER D.	OK / NG	/ /
	ERQ transmission	6-18-3	Send ERQ PDU from ROUTER C to each of the other 3 routers (A, B, D). Confirm receipt of ERP PDU from each of the 3 routers.	OK / NG	/ /
	ERQ transmission	6-18-4	Send ERQ PDU from ROUTER A to each of the other 3 routers (B, C, D). Confirm receipt of ERP PDU from each of the 3 routers.	OK / NG	/ /

6. ATN Router Network Test		Test Item	Procedure	Result	Date/Time
Carrier media restoration of ROUTER C-ROUTER A circuit and route addition	Data link, VC, and router connection re-establishment	6-19-1	Restore the ROUTER C-ROUTER A router connection. Confirm router connection is re-established between ROUTER C and ROUTER A.	OK / NG	/ /
	Routing table entries for ROUTER C	6-19-2	Following the exchange of UPDATE PDUs, verify at ROUTER C that route information for all 3 other routers exists, and that the route to ROUTER A is one direct hop.	OK / NG	/ /
	Routing table entries for ROUTER A	6-19-3	Following the exchange of UPDATE PDUs, verify at ROUTER A that route information for all 3 other routers exists, and that the route to ROUTER C is one direct hop.	OK / NG	/ /

Sequence diagram to be inserted

Table 25 Router Failure and Recovery Test Procedure: Routers A, B, C, D

6. ATN Router Network Test		Test Item	Procedure	Result	Date/Time
Failure and recovery of ROUTER A	Failure of ROUTER A	6-20-1	<p>Simulate failure and recovery of ROUTER A by rebooting the router.</p> <p>At failure:</p> <ul style="list-style-type: none"> • At ROUTER B, verify that routing information for ROUTER A is deleted, but that routing information for ROUTER C and ROUTER D remains. • At ROUTER C, verify that routing information for ROUTER A is deleted, but that routing information for ROUTER B and ROUTER D remains. • At ROUTER D, verify that routing information for ROUTER A is deleted, but that routing information for ROUTER B and ROUTER C remains. 	OK / NG	/ /
	Recovery of ROUTER A	6-20-2	<p>Check that the ROUTER A-ROUTER B and ROUTER A-ROUTER C router connections are automatically re-established after ROUTER A recovers.</p> <p>After recovery:</p> <ul style="list-style-type: none"> • At ROUTER A, check that routing information is added for ROUTER B, ROUTER C and ROUTER D. • At ROUTER B, check that routing information for ROUTER A is added. • At ROUTER C, check that routing information for ROUTER A is added. • At ROUTER D, check that routing information for ROUTER A is added. 	OK / NG	/ /
Failure and recovery of ROUTER B	Failure of ROUTER B	6-21-1	<p>Simulate failure and recovery of ROUTER B by rebooting the router.</p> <p>At failure:</p> <ul style="list-style-type: none"> • At ROUTER A, verify that routing information for ROUTER B is deleted, but that routing information for ROUTER C and ROUTER D remains. 	OK / NG	/ /

6. ATN Router Network Test		Test Item	Procedure	Result	Date/Time
			<ul style="list-style-type: none"> At ROUTER C, verify that routing information for ROUTER B is deleted, but that routing information for ROUTER A and ROUTER D remains. At ROUTER D, verify that routing information for ROUTER B is deleted, but that routing information for ROUTER A and ROUTER C remains. 	OK / NG	/ /
	Recovery of ROUTER B	6-21-2	<p>Check that the ROUTER A-ROUTER B and ROUTER B-ROUTER D router connections are automatically re-established after ROUTER B recovers.</p> <p>After recovery:</p> <ul style="list-style-type: none"> At ROUTER B, check that routing information is added for ROUTER A, ROUTER C and ROUTER D. At ROUTER A, check that routing information for ROUTER B is added. At ROUTER C, check that routing information for ROUTER B is added. At ROUTER D, check that routing information for ROUTER B is added. 	OK / NG	/ /
Failure and recovery of ROUTER C	Failure of ROUTER C	6-22-1	<p>Simulate failure and recovery of ROUTER C by rebooting the router.</p> <p>At failure:</p> <ul style="list-style-type: none"> At ROUTER A, verify that routing information for ROUTER C is deleted, but that routing information for ROUTER B and ROUTER D remains. At ROUTER B, verify that routing information for ROUTER C is deleted, but that routing information for ROUTER A and ROUTER D remains. At ROUTER D, verify that routing information for ROUTER C is deleted, but that routing information for ROUTER A and ROUTER B remains. 	OK / NG	/ /

6. ATN Router Network Test		Test Item	Procedure	Result	Date/Time
	Recovery of ROUTER C	6-22-2	<p>Check that the ROUTER A-ROUTER C and ROUTER C-ROUTER D router connections are automatically re-established after ROUTER C recovers.</p> <p>After recovery:</p> <ul style="list-style-type: none"> • At ROUTER C, check that routing information is added for ROUTER A, ROUTER B and ROUTER D. • At ROUTER A, check that routing information for ROUTER C is added. • At ROUTER B, check that routing information for ROUTER C is added. • At ROUTER D, check that routing information for ROUTER C is added. 	OK / NG	/ /
Failure and recovery of ROUTER D	Failure of ROUTER D	6-23-1	<p>Simulate failure and recovery of ROUTER D by rebooting the router.</p> <p>At failure:</p> <ul style="list-style-type: none"> • At ROUTER A, verify that routing information for ROUTER D is deleted, but that routing information for ROUTER B and ROUTER C remains. • At ROUTER B, verify that routing information for ROUTER D is deleted, but that routing information for ROUTER A and ROUTER C remains. • At ROUTER C, verify that routing information for ROUTER D is deleted, but that routing information for ROUTER A and ROUTER B remains. 	OK / NG	/ /
	Recovery of ROUTER D	6-23-2	<p>Check that the ROUTER B-ROUTER D and ROUTER C-ROUTER D router connections are automatically re-established after ROUTER D recovers.</p> <p>After recovery:</p> <ul style="list-style-type: none"> • At ROUTER D, check that routing information is added for ROUTER A, ROUTER B and ROUTER C. • At ROUTER A, check that routing information for ROUTER D is added. • At ROUTER B, check that routing information for ROUTER D is added. • At ROUTER C, check that routing information for ROUTER D is added. 	OK / NG	/ /

Sequence diagram to be inserted

Table 26 Echo Test Procedure: Routers A, B, C, D

6. ATN Router Network Test		Test Item	Procedure	Result	Date/Time
CLNP Echo Test between routers	ERQ transmission	6-24-1	Send ERQ PDU from ROUTER A to each of the other 3 routers (B, C, D). Confirm receipt of ERP PDU from each of the 3 routers.	OK / NG	/ /
	ERQ transmission	6-24-2	Send ERQ PDU from ROUTER B to each of the other 3 routers (A, C, D). Confirm receipt of ERP PDU from each of the 3 routers.	OK / NG	/ /
	ERQ transmission	6-24-3	Send ERQ PDU from ROUTER C to each of the other 3 routers (A, B, D). Confirm receipt of ERP PDU from each of the 3 routers.	OK / NG	/ /
	ERQ transmission	6-24-4	Send ERQ PDU from ROUTER D to each of the other 3 routers (A, B, C). Confirm receipt of ERP PDU from each of the 3 routers.	OK / NG	/ /

Sequence diagram to be inserted