

AMHS Workshop – SP/2

# CAR/SAM Regional AMHS Transition Plan

ATS Message Handling  
System (AMHS)  
Workshop

**Bangkok, Thailand  
27-28 January 2010**



**Federal Aviation  
Administration**



# BACKGROUND

□ The scope of the CAR/SAM ATN Task Force is to:

- Ensure smooth transition from Aeronautical Fixed Telecommunication Network (AFTN) to AMHS environment and
- Prevent any possible interruption in the AFTN and Air Traffic Voice service operation during the transition period.



# BACKGROUND

- ❑ Transition Planning in the CAR/SAM Region is taking in consideration the following:
  - The new ATN/IPS introduced the ATN/IPS in parallel to ATN/OSI.
  - Doc 9578 (Manual of the ATN) is currently obsolete
  - Doc 9880 has partially replaced Doc 9705.
  - Doc 9896 (ATN/IPS) has provisions for ATSMHS and all applications over TCP/IP while specifying an IPv6 network service.
  - Doc 9739 (Comprehensive ATN Manual) to be updated.



# Existing ATC Voice and AFTN Configuration

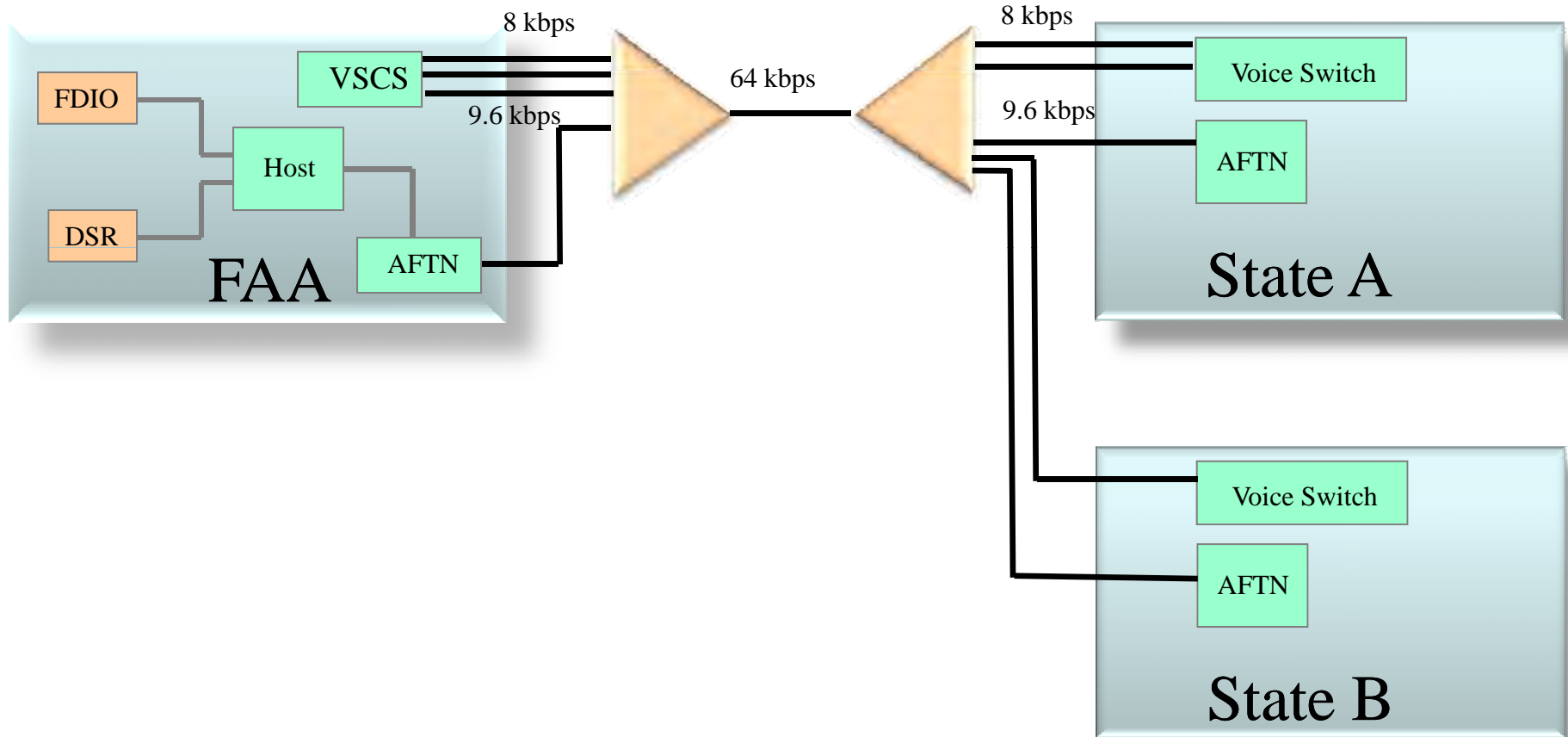

# CAR/SAM Existing International AFTN Backbone

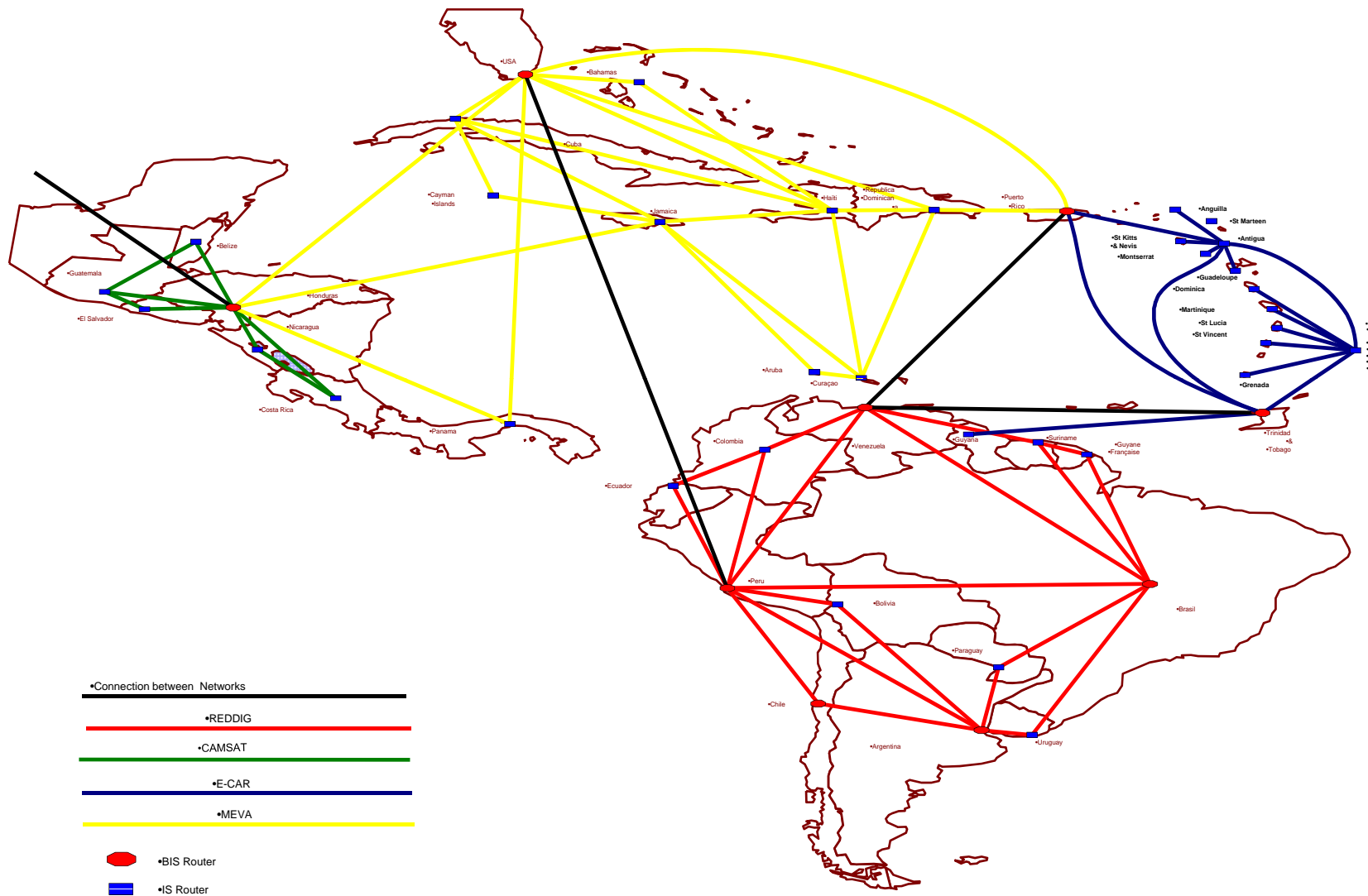

27-28 January 2010



Federal Aviation  
Administration

# CAR/SAM Regional ATN Backbone Architecture

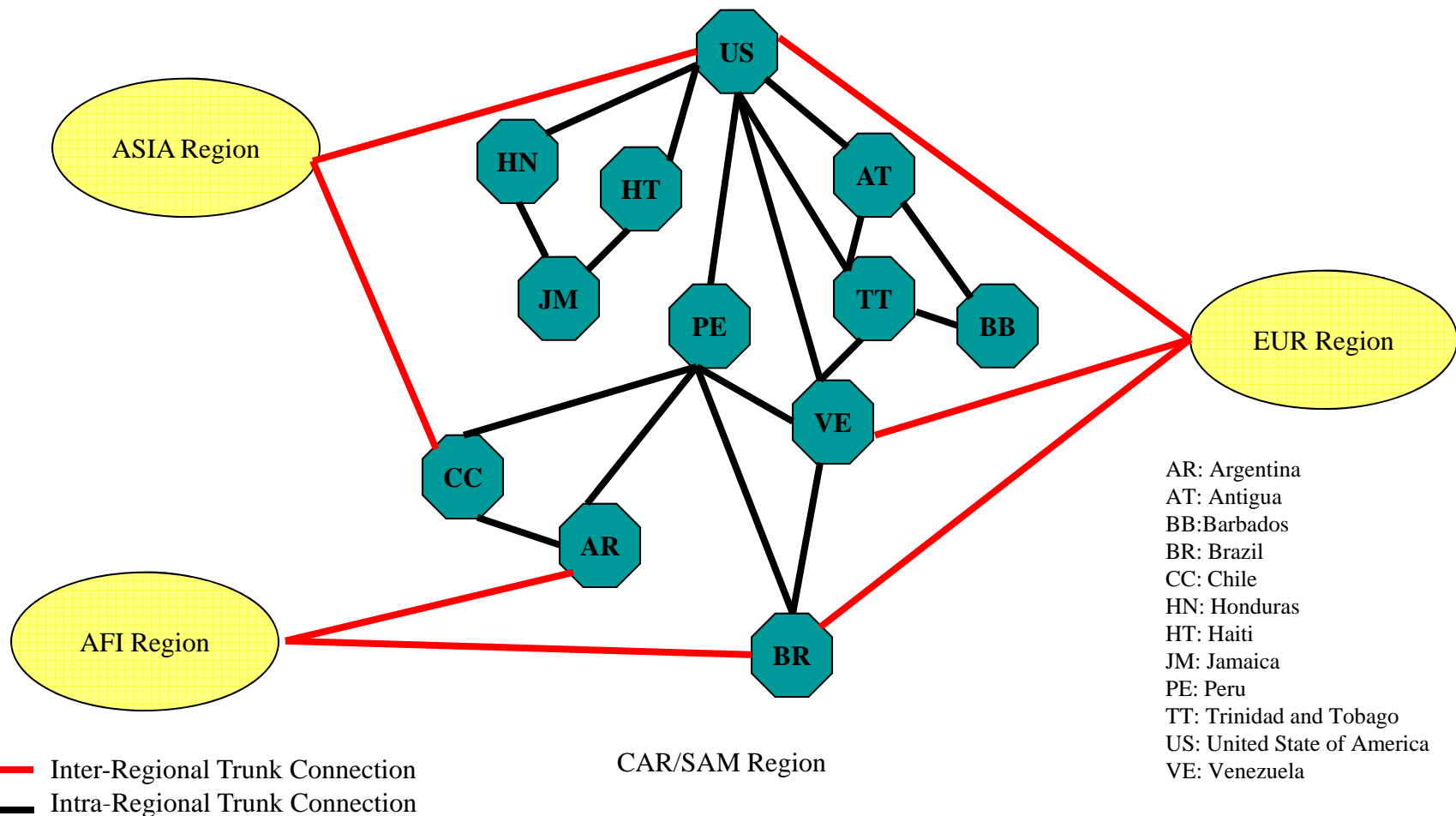

# ATN Architecture in the CAR/SAM

- Implementation aspects being considered:
  - **Regional Implementation**
    - Continue with trials to determine the bandwidth requirements for ground-ground ATN applications
    - Use CAR/SAM IPv4 addressing scheme for intraregional links
    - Complete the CAR/SAM Regional address Plan for IPv6
    - Complete the study on the optimum ATN CAR/SAM Architecture
    - Registration of IPv6 addresses with IANA/LIR should be *reconsidered* due to use of closed and private network and cost.

# ATN Architecture in the CAR/SAM

- Implementation aspects being considered:
  - **National Implementation**
    - Centralize technical management
    - Avoid the employment of different equipment providers
    - Based on COTS and state-of-the-art IP Products
    - Must be scalable to increases in air traffic volume



# Transitional Issues

- Transition to IPv6 from existing AMHS platform
- AMHS Network Protocols
  - CLNP/TP4
  - IPS-based networks
- MTA to MTA Communication
- Dual Operation of AMHS and AFTN
- Alternative Routing: A well coordinated upgrade of the circuit data rate table will be needed to support alternative routing
- AFTN circuits Upgrades
- AMHS Extended Service: Directory, Attached Files, Security
- Air Traffic Service Message Management Center (AMC) operation



# Transitional Issues

- ❑ Intra-Region MTA routing during the AFTN/AMHS transition period: should be based on existing AFTN routing.
- ❑ Intra-Region MTA routing at End-State Environment: MTA to any MTAs operation when MTAs in the region are fully implemented.
- ❑ Inter-Region MTA Routing during transition period: should follow AFTN routing and slowly transition between regional backbone MTAs.
- ❑ Inter-Region MTA Routing at End-State Environment: MTA to any MTAs operation when all MTAs are fully implemented and common network protocol is in place.



# Transitional Plan - IP

## IPv4 Intra-Regional and IPv6 to External ICAO Regions

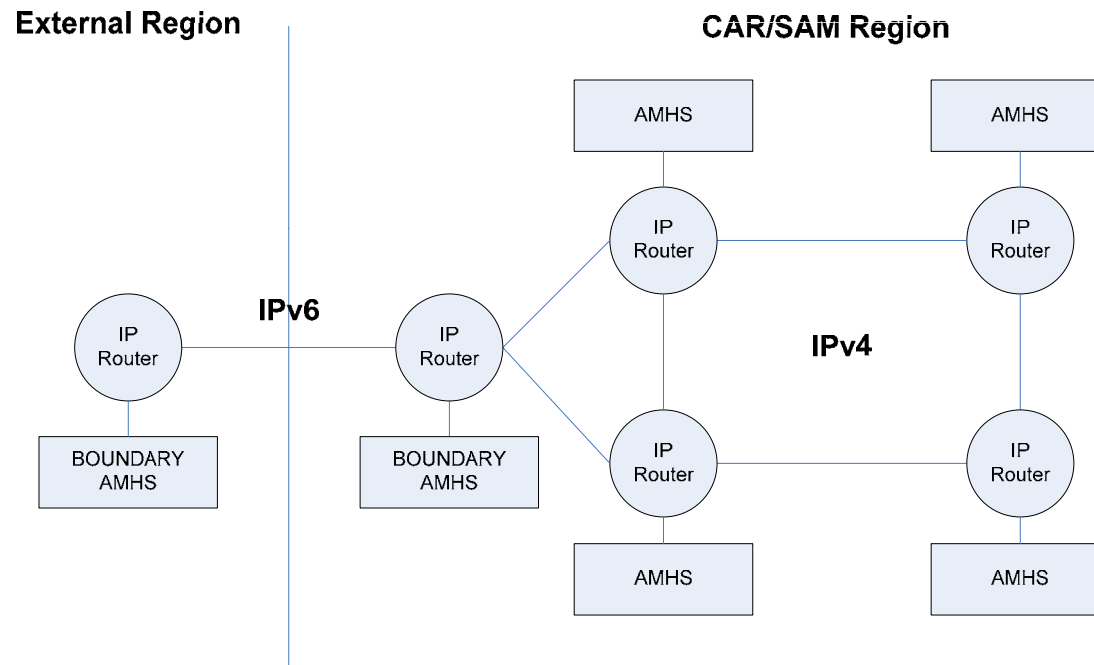

# Protocol Stacks for Current AMHS Applications

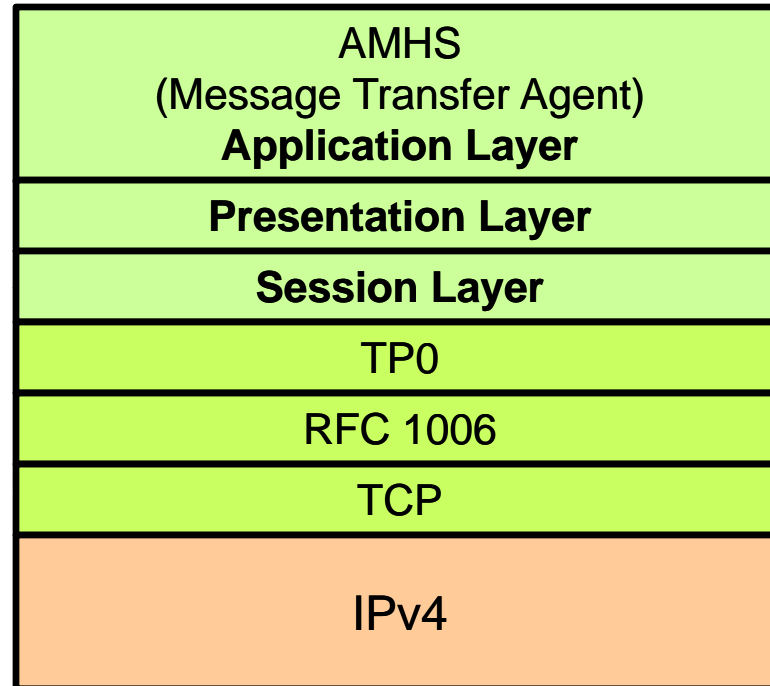

# Transitional Plan - IP

## IPv4 and IPv6 Intra-Regional, and IPv6 to External ICAO Regions

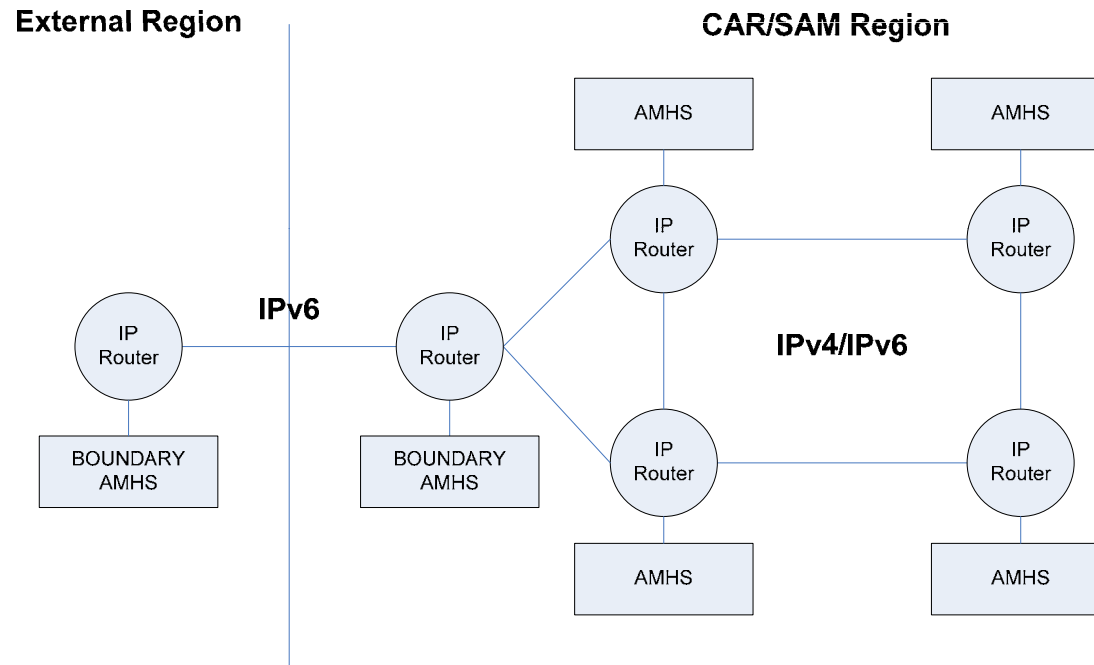

# Protocol Stacks for Transition-Phase AMHS Applications

AMHS (Message Transfer Agent) <b>Application Layer</b>	
<b>Presentation Layer</b>	
<b>Session Layer</b>	
TP0	TP0
RFC 1006	RFC 2126
TCP	TCP
IPv4	IPv6



# End State IPv6 for Intra-Region and Inter-Region

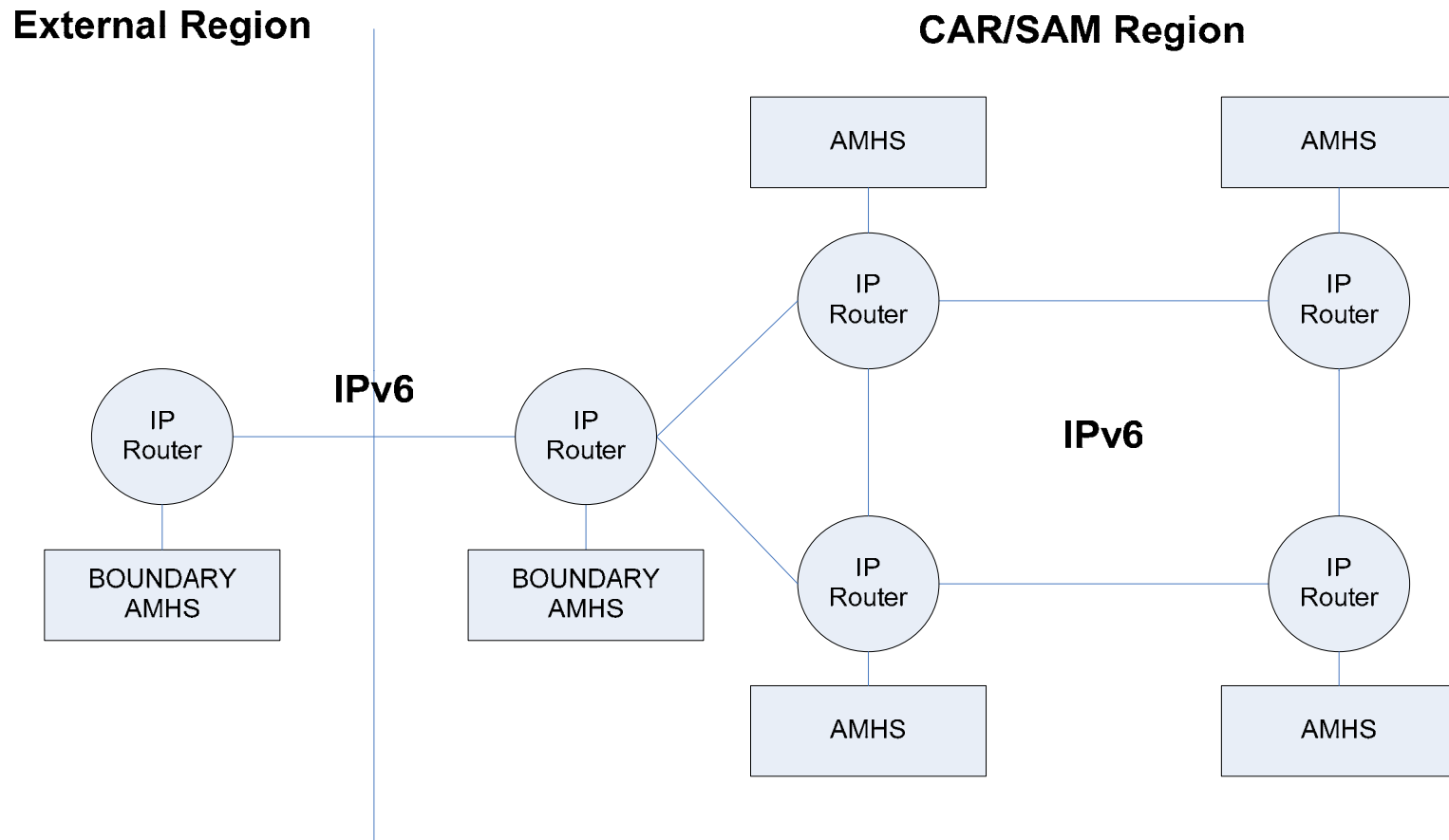

# IP Transitional Issues

- ❑ MTA to support IPv6 has not been fully developed by the AMHS system providers.
- ❑ The Technical Manual for the IPS (ICAO Doc. 9896) is in the process to be finalized by the Aeronautical Communication Panel (ACP). However, ICAO Doc. 9880 has partially replaced Doc 9705 and Part II B for AMHS is now available.
- ❑ Initial implementations in the ICAO European Region are using AMHS over IPv4 in separate sub-regions. Two of these sub-regions are interconnected via IPv6 using a network address and protocol translation technique whereby IPv4 messages are converted to IPv6 across the interface and then back to IPv4.
- ❑ The Asia/Pacific region has resolved the network protocol different issues with European region using IPv4 network protocol.
- ❑ A global AMHS network coordination is required to ensure smooth operation.
- ❑ Implementing security measures.
- ❑ IPv6 addressing scheme needs to be developed for AMHS. IPv4 global addressing scheme has been proposed by CAR/SAM region and potential to be accepted by Asia/Pac region.



# Evolving ATN Interconnection of A/G and G/G Routers

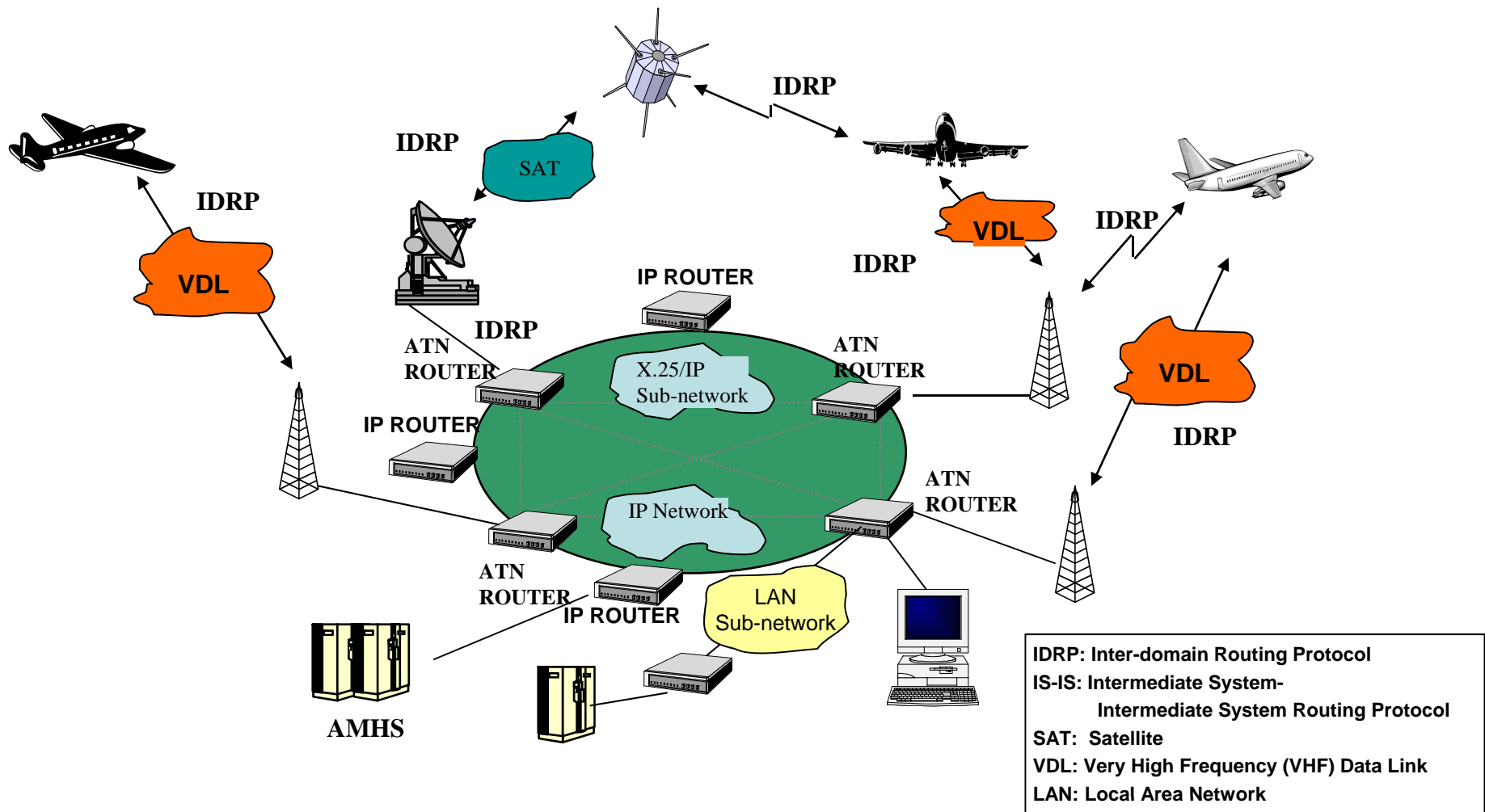

# Implementation Documents Needed

## ICAO Regional ATN/AMHS Implementation Documents



CAR/SAM AMHS  
Network Status Table

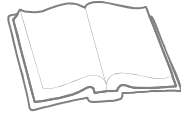

CAR/SAM AMHS  
Network Backbone  
Trunk



CAR/SAM TCP/IP  
Routing Policy



IPv6 Address Scheme



IP Router ICD



AMHS Routing  
Policy



AMHS Address  
Scheme



CAR/SAM Directory  
Service



AMHS and IP Router  
Compatibility Test Procedure



AMHS VPN Security



CAR/SAM ATN Task  
Force Task  
Assignment

# CAR/SAM Regional AMHS Implementation Documentation

AMHS Transition Plan would include the following appendices to address variety of issues:

- Appendix I CAR/SAM AMHS Network Status Table:
  - Document AMHS implementation status of the States
  
- Appendix II CAR/SAM AMHS Network Backbone Trunks:
  - Document the Telecommunication Backbone/circuits
  
- Appendix III CAR/SAM TCP/IP Routing Policy:
  - Specify the routing for primary route and alternate routes for each AMHS connection. It also specifies the regional backbone hubs and its policy to route traffic



# CAR/SAM Regional AMHS Implementation Documentation

- Appendix IV IPv6 Addressing Scheme
  - Global address designation
- Appendix V IP Router Interface Control Document
  - Specify the lower three layers of the router and
- Appendix VI AMHS Routing Policy
  - Address MTA to MTA within the region and MTA to other MTA outside region during the transition and end state (global network protocol compatibility environment)
- Appendix VII AMHS Addressing Scheme



# CAR/SAM Regional AMHS Implementation Documentation

- Appendix VIII CAR/SAM Directory Service Issue needs to be evaluated
- Appendix IX AMHS and IP Router Compatibility Test Procedure Ensure hardware and software will be compatible between different platforms
- Appendix X AMHS VPN Security Address network protection measure
- Appendix XI CAR/SAM ATN Task Force Task Assignments Assignment Documents actions and efforts by the state members



# Operation Considerations

## MTA to any MTA (via IP)

- This is the end state goal. In the interim, the regional major hub should take active role to ensure the smooth operation.

## Dual operation of AFTN and AMHS

- Dual Operation during transition period will require regional major hubs to act quickly to prevent significant network problems.

## Regional AMHS Management Center (AMC)

- ICAO regional office should be responsible for coordination and validation of information provided by States before distribution to the AMC. ICAO regional office should also be responsible resolving addressing scheme conflict.

## System performance standards

- Develop System Performance Standards to address legal recording, tracking message, delivering of messages, etc.

# Acronyms

- **AFS** Aeronautical Fixed Service
- **ACP** Aeronautical Communication Panel
- **AFTN** Aeronautical Fixed Telecommunication Network
- **AIDC** Air Traffic Service Inter-Facility Data Communication
- **AMHS** Air Traffic Service Message Handling System
- **ATC** Air Traffic Control
- **ATN** Aeronautical Telecommunication Network
- **CIDIN** Common ICAO Data Interchange Network
- **CLNP** Connection Less Network Protocol
- **DOTS** Dynamic Oceanic Tracking System
- **FASID** Facilities and Services Implementation Document
- **FIR** Flight Information Region
- **ICAO** International Civil Aviation Organization
- **IDRP** Inter Domain Routing Protocol
- **IP** Internet Protocol
- **IPS** Internet Protocol Suites
- **MTA** Message Transfer Agent
- **MTCU** Message Transfer and Control Unit
- **MTS** Message Transfer System
- **NOTAM** Note to Air Men
- **OSI** Open System Interface
- **SARP** Standard and Recommended Practices
- **SND CF** Sub Network Dependent Convergence Function
- **UA** User Agent



# Conclusion

- **Provide up to date AMHS implementation planning in the region.**
- **Present AMHS implementation issues.**
- **The need to finalizing related ICAO documents before the States can make investment.**
- **The region needs to complete its existing plan to implement AMHS over TCP/IP network before consider any improvement.**

