



1090ES ADS-B Approval by CAAC

Mr. Yang Honghai and Ms. Chen Ye
from CAAC



Main contents

- ❑ Information Bulletin IB-FS-2008-002
ADS-B: flight operation
- ❑ Approval methods and applicable regulations to
ADS-B airborne equipments by CAAC
- ❑ Introduction to CTSO-C166b
- ❑ Introduction to AC-91-FS/AA-2010-14



IB-FS-2008-002

- Released in Sep. 2008
- Focusing ADS-B concept, theory and development information
- Purpose
 - Introduce the benefits of ADS-B for flight operation
 - Fulfill the requirements for some certain foreign area
 - Call for the preparation in advance
 - Regulation warm-up



IB contents

1. General

2. Basic Theory

3. Usage (OUT / IN)

4. Airborne equipage

(1 0 9 0 ES / UAT / VDL4)

5. Development situation

Att. 1. Abbreviations

Att.2 Related technical standards

Att. 3 Operation requirements in Australia



Technical Standards

Data link :

1090ES

UAT

VDL4

Application :

OUT

NRA

RAD

APT

IN

TIS-B

FIS-B

M&S



Airborne equipments necessary for 1090ES ADS-B

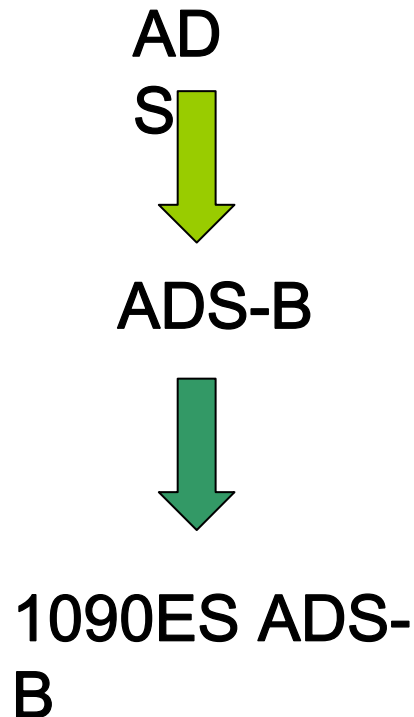

OUT function only, based on S mode transponder

- S mode transponder
- GNSS receiver

OUT and **IN** functions, based on S mode transponder

- S mode transponder
- GNSS receiver
- 1090 receiver
- CDTI: Cockpit Display of Traffic Information



Main contents

- ❑ Information Bulletin IB-FS-2008-002
ADS-B: flight operation
- ❑ Approval methods and applicable regulations to
ADS-B airborne equipments by CAAC
- ❑ Introduction to CTSO-C166b
- ❑ Introduction to AC-91-FS/AA-2010-14



Approval methods and applicable regulations to ADS-B airborne equipments by CAAC

- **CCAR21**
 - CCAR-21-R3** Certification Procedures for Civil Aviation Products and Parts
 - AP-21-06R3** Certification Procedures for Civil Aviation Materials, Parts and Appliances
- **Approval of equipments**
 - **Domestic : CTSOA**
 - CCAR-37** Civil Aeronautical Materials, Parts and Appliances Technical Standard Order
 - CTSO-C166b** Extended Squitter Automatic Dependent Surveillance-Broadcast (ADS-B) and Traffic Information Service-Broadcast (TIS-B) Equipment Operating on the Radio Frequency of 1090 Megahertz
 - **Imported : VDA or CTSOA**
 - AP-21-01R2** Validation Procedures for Import Civil Aviation Products and Parts
 - AP-21-AA-2009-19** Validation Procedures for the U.S. Civil Aviation Products and TSO Articles
 - CTSO-C166b** Extended Squitter Automatic Dependent Surveillance-Broadcast (ADS-B) and Traffic Information Service-Broadcast (TIS-B) Equipment Operating on the Radio Frequency of 1090 Megahertz



Approval methods and applicable regulations to ADS-B airborne equipments by CAAC (continued)

□ Approval of installation

- For original aircraft manufactures: **TC**、**VTC**、**TDA** or **Changes to these certificates**

AP-21-03R3 Type Certification Procedures

AP-21-01R2 Validation Procedures for Import Civil Aviation Products and Parts

AP-21-AA-2009-19 Validation Procedures for the U.S. Civil Aviation Products and TSO Articles

- Other methods: **STC**、**MDA**

AP-21-14 Supplemental Type Certification Procedures

AP-21-15 Major Modification Design Approval Procedures for Import Civil Aircraft

- ### □ **AC-91-FS/AA-2010-14** Airworthiness and Operational Approval of Automatic Dependent Surveillance-Broadcast Application in Non-Radar Areas via 1090 MHz Extended Squitter



Main contents

- ❑ Airborne equipments necessary for 1090ES ADS-B
- ❑ Approval methods and applicable regulations to ADS-B airborne equipments by CAAC
- ❑ Introduction to CTSO-C166b
- ❑ Introduction to AC-91-FS/AA-2010-14



Introduction to CTSO-C166b

Title

- Extended Squitter Automatic Dependent Surveillance-Broadcast (ADS-B) and Traffic Information Service-Broadcast (TIS-B) Equipment Operating on the Radio Frequency of 1090 Megahertz

Date of issue

- April 30, 2010

Referenced RTCA/DO

- DO-260B: Minimum Operational Performance Standards for 1090 MHz Extended Squitter Automatic Dependent Surveillance-Broadcast (ADS-B) and Traffic Information Service-Broadcast (TIS-B)

Introduction to CTSO-C166b (continued)

□ Purpose

- For manufactures applying for a CTSOA for 1090ES ADS-B and TIS-B equipment.
- Regulate the minimum performance standards 1090ES ADS-B and TIS-B equipment first meet for approval and identification with the applicable marking.

□ Applicability

- New applications of 1090ES ADS-B and TIS-B equipment after the effective data of this CTSO.



Introduction to CTSO-C166b (continued)

- Requirements
 - Functionality
 - Failure condition classification
 - Functional qualification
DO-260B
 - Environmental qualification
DO-260B、 DO-160D
 - Software qualification
DO-178B
 - Electronic hardware qualification
DO-254
 - Deviation



Introduction to CTSO-C166b (continued)

- Marking

- Data requirements
 - Application data requirements
 - Manufacture data requirements
 - Furnished data requirements

- Referenced documents



Main contents

- ❑ Information Bulletin IB-FS-2008-002
ADS-B: flight operation
- ❑ Approval methods and applicable regulations to
ADS-B airborne equipments by CAAC
- ❑ Introduction to CTSO-C166b
- ❑ Introduction to AC-91-FS/AA-2010-14



Introduction to AC-91-FS/AA-2010-14

Title

- Airworthiness and Operational Approval of Automatic Dependent Surveillance-Broadcast Application in Non-Radar Areas via 1090 MHz Extended Squitter

Date of issue

- May 10, 2010

Applies to

- The **manufactures or modification units** who want to get **airworthiness approval** for ADS-B airborne equipment; the **operators** under CCAR91、121、135 who want to get **operational approval** for ADS-B airborne system.



Introduction to AC-91-FS/AA-2010-14 (continued)

- Applicability
 - Based on 1090 ES ADS-B OUT technology
- Referenced RTCA/DO
 - DO-260/260A/260B
 - DO-303 : Safety, performance and interoperability requirements document for ADS-B-NRA application
 - DO-264: Guidelines for approval of the provision and use of air traffic services supported by data communications
- Main contents



Introduction to AC-91-FS/AA-2010-14 — 3 Definitions

□ b. ADS-B OUT

OUT is the basic function of onboard ADS-B equipment, which shall have adequate surveillance data provision capability, ADS-B message processing (encoding and generation) capabilities, and ADS-B message transmission capabilities.

ADS-B OUT system is automatic since it functions **without intervention from the flight crew** as long as the necessary avionics are in place, connected and functioning.



Introduction to AC-91-FS/AA-2010-14 — 3 Definitions (continued)

□ c. ADS-B IN

ADS-B IN. ADS-B IN refers to the ability to receive and display ADS-B messages and broadcast services, both from the ground and directly from other aircraft so as to provide operational support for the crew.

A typical application of ADS-B IN is the Cockpit Display of Traffic Information (CDTI) via which the crew knows the operation status of other aircrafts so as to improve their air traffic situation awareness.



Introduction to AC-91-FS/AA-2010-14 —

4 Reference Documents

- a. CTSO-C166b
- b. Canada AC700-009
- c. EASA AMC 20-24
- d. RTCA DO-260/EUROCAE ED-102
- e. RTCA DO-260A
- f. RTCA DO-260B



Introduction to AC-91-FS/AA-2010-14 — 6 ATC Issues

- The AC supports 5NM separation in Non Radar Airspace

- Assumptions & Att.1 ATS Environment
 - position quality indicators
 - the procedures contained in the ICAO Doc 4444 PANS-ATM.
 - traffic density
 - Direct VHF Controller-Pilot Communication
 - Abnormal /Emergency procedures

- Separation minimum/ Flight Plan/ Radio communication



Introduction to AC-91-FS/AA-2010-14 —

7 Airworthiness Requirements

- Airworthiness certification objectives
 - Data delivered should satisfy the airborne domain requirements in DO-303 section 3.4
- ADS-B system
 - The minimum requirements to the overall ADS-B system

Parameter	Requirement
Integrity	$10^{-5}/\text{fh}$
Continuity	$2 \times 10^{-4}/\text{fh}$
Horizontal Position Latency	1.5 sec/95%



Introduction to AC-91-FS/AA-2010-14 —

7 Airworthiness Requirements (continued)

- ADS-B transmit system
 - Transmit data requirements, relevant tests documents, encoding of horizontal position quality indicators, antenna installation, etc.
 - Transmit data
 - ICAO 24 bit aircraft address
 - Horizontal position
 - Horizontal position quality indicators (Integrity, Accuracy)
 - Barometric altitude
 - Aircraft identification
 - Special position identification
 - Emergency status and emergency indicator
 - Version number



Introduction to AC-91-FS/AA-2010-14 — 7 Airworthiness Requirements (continued)

- ✓ Integrity : HPL, Rc
- ✓ Accuracy : HFOM
- ✓ DO260 : NUC
- ✓ DO260A/DO260B : NIC, NAC, SIL

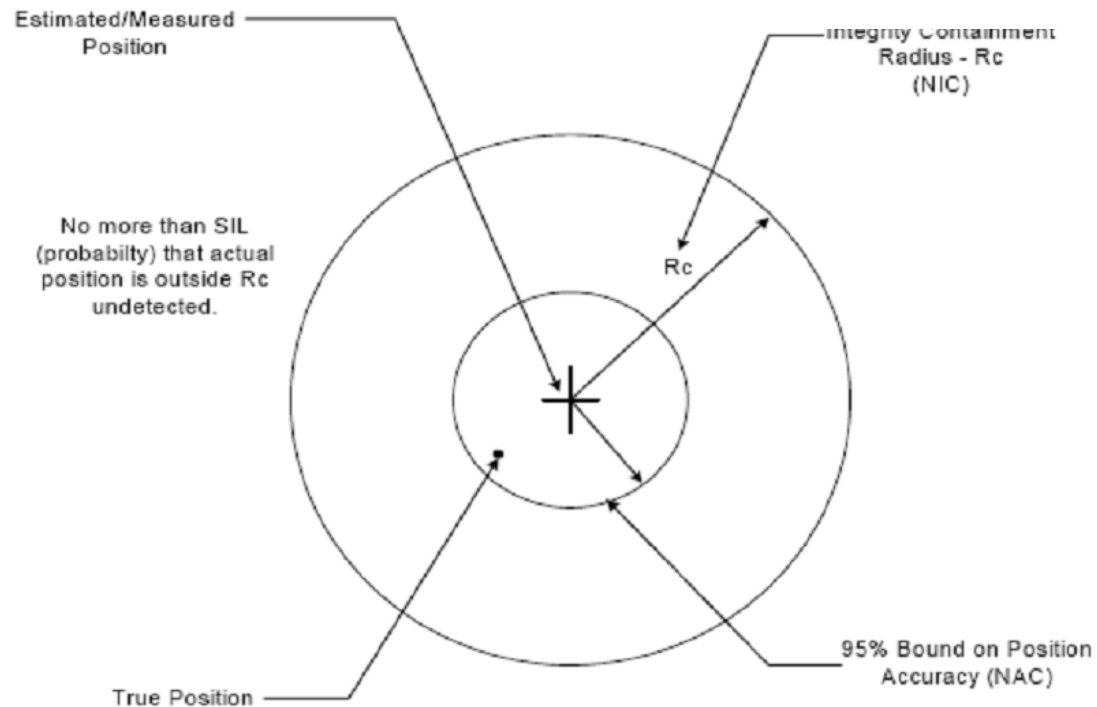
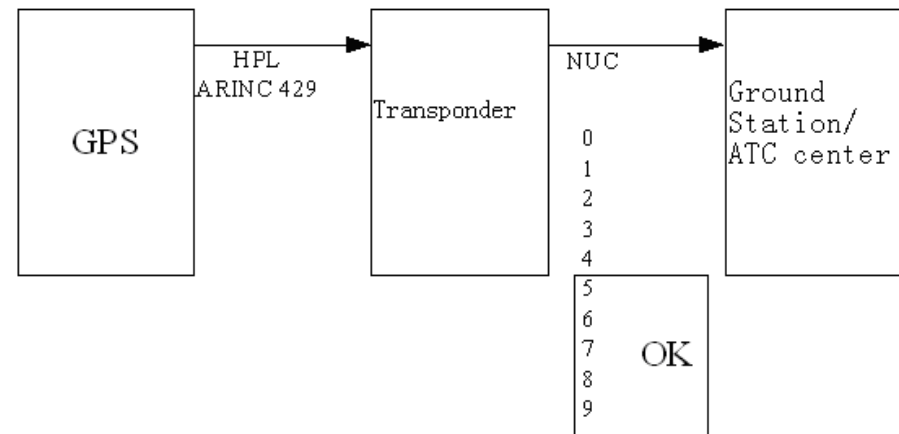

Introduction to AC-91-FS/AA-2010-14 —

7 Airworthiness Requirements (continued)

- Horizontal position data sources
 - The minimum requirements should be met

Parameter	Requirement
Horizontal position source	
● Accuracy (95%)	5 NM Sep: 926 m
● Integrity	
✓ Containment Radius (Rc)	5 NM: Rc=2 NM
✓ Source Failure Probability	$10^{-4}/h$
✓ Alert Failure Probability	10^{-3} (per position source failure event)
✓ Time to Alert	5 NM Sep: 10 sec

- Data sources
 - Primary position data source: GPS; Alternative compliant position data sources; Temporary back-up position data sources



Introduction to AC-91-FS/AA-2010-14 —

7 Airworthiness Requirements (continued)

- Barometric altitude data sources
 - Requirements, specified tolerance, altitude resolution, other more stringent requirements
- Aircraft identification
- Special position identification
- Emergency status/ Emergency indicator
- Airworthiness considerations regarding optional provisions



Introduction to AC-91-FS/AA-2010-14 —

8 Airworthiness Approval

- Equipments approval
 - Domestic equipments: CTSOA
 - Imported equipments: VDA or CTSOA
- Installation approval
 - For original aircraft manufactures: TC、 VTC、 TDA or changes to TC、 VTC、 TDA
 - Other methods: STC、 VSTC、 MDA
- Existing installation
 - Compliance statement
 - Design review and inspection of the installed system
- Airworthiness compliance



Introduction to AC-91-FS/AA-2010-14 — 9 & 10

- 9. Operational considerations
 - 9.1 Operational Safety
 - 9.2 Operation Manual
 - 9.3 Training

- 10. Maintenance



Introduction to AC-91-FS/AA-2010-14 — 11 Operation Approval

□ 11.1 Application documents

- a. Evidence showing that the airworthiness approval has been obtained for onboard equipment
- b. Minimum Equipment List.
- c. Operation Manual.
- d. Training program.
- e. Maintenance program.

□ 11.2 Method of approval

operators under CCAR91: letter of authorization
operators under CCAR 121 and 135:
operation specifications (A0081)



Thank you!

