

The background of the slide is a dark blue grid with faint white architectural blueprints. The blueprints include various geometric shapes, lines, and symbols, such as a large rectangular structure on the left, a circular diagram with a crosshair on the right, and a staircase on the bottom left. The word "THALES" is prominently displayed in the center in a large, white, sans-serif font.

THALES

SMARTER | SAFER

A FOCUS ON TACTICAL ATFM

ICAO ATFM Workshop
Beijing, 29th-30th October 2014

Contents

- ◆ **Thales has been involved in ATFM for over a decade**
 - Closely linked to ATM/ANSP; CAMU Milestone South Africa
- ◆ **Recent Thales ATFM developments and activities**
- ◆ **Enhanced native ATFM features in ATM product (TopSky-ATC)**
- ◆ **Acquisition of Egis Avia products**
 - MAESTRO AMAN, DMAN and XMAN now in portfolio
- ◆ **Maturing of SESAR/FABEC projects and internal R&D**
 - Complexity Management, XMAN, Meteorological products ...
- ◆ **Establishment of “The Link” laboratory**
 - Include Airlines and Airport Operators in addition to ANSPs
- ◆ **TopSky-ATFM Generation II – Web Services**
 - Preparing for distributed, regional ATFM



ICAO Classification of ATFM Measures

ICAO Doc 9971 AN/485 Manual on Collaborative Air Traffic Flow Management, Part II, Second Edition - 2014

ATFM Measures			
	Strategic	Pre-Tactical	Tactical
Vertical			Rerouting (Level Capping Scenarios)
Lateral			Fix Balancing
			Rerouting (Rerouting Scenarios)
Longitudinal			Rerouting (Alternative Rerouting Scenarios)
	Playbook Routes	Playbook Routes	Playbook Routes
			Miles-In-Trial
Time			Minutes-In-Trial
			Minimum Departure Intervals
	Ground Delay Program	Ground Delay Program	Slot Swapping
			Ground Delay Program
		Ground Stop	
	Airborne Holding		Airborne Holding

ATFM measures are predominately tactical in nature

Right Tool for the Right Problem for the Right Actors

ATFM FUNCTIONAL CATEGORY	Trajectory Optimization	Capacity Management	Sequencing	Metering	Procedures
Reduce airborne holding			Red	Red	Yellow
Reduce airport taxi time			Red		
Improve predictability of flight operations	Red		Red	Yellow	
Improve predictability of airport facility use			Yellow	Red	
Manage controller complexity / workload	Yellow	Red	Red	Red	Yellow
Manage utilization of resources		Yellow	Yellow	Red	Yellow
Minimize weather impact	Red		Yellow	Yellow	
ACTORS	ANSP (operational ATM)			Strategic or Tactical	AO, ANSP, Airport

Implementation can be staged (ABSU rollout etc.)

Establishing Common Situational Awareness

- ◆ **Intelligent data fusion from multiple ATM Systems and FIRs**
 - Built-in ATM-grade, BADA-capable Flight Data Processor
 - 4-D, WGS-84 flight profiles enhanced by surveillance and controller actions
 - Multiple data sources (AFTN, FDP in XML – future FIXM & SWIM)
- ◆ **National or regional coverage with maps, nav aids, routes...**
- ◆ **Consolidated traffic picture, load, capacity, restrictions and weather**
 - Global assessment of potential congestion and disruptive events

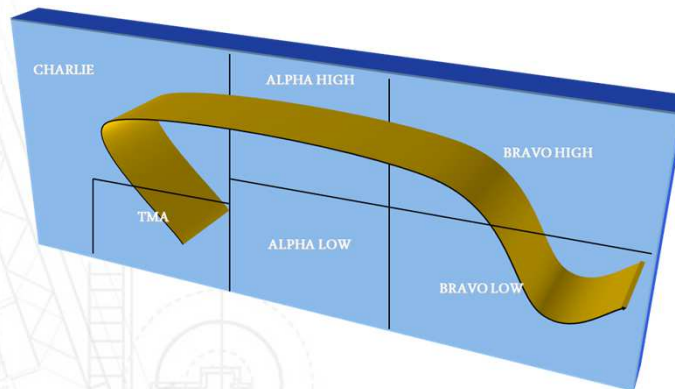

Trajectory Optimization; Capacity Management → ...

Weather Alerting and Avoidance

- ◆ Real time and predicted thunderstorm data and imagery
- ◆ Automatic detection of infringing flights (ATM-grade conflict probe)
- ◆ Automatic or manual weather-avoidance reroutes (CORA)

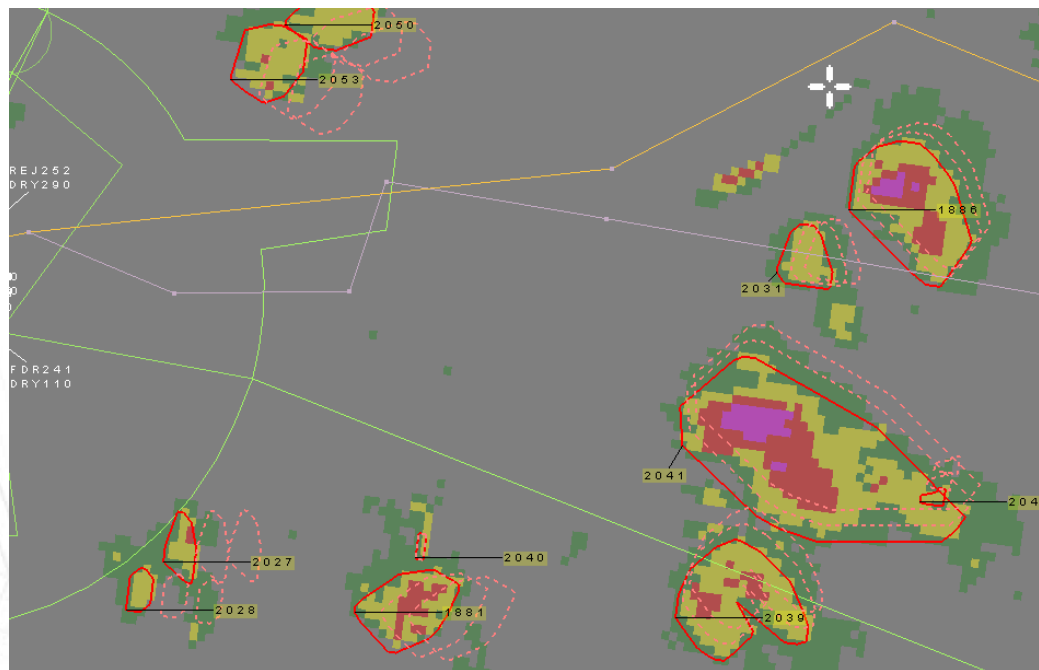

Trajectory Optimization → Minimize Weather Impacts

Dynamic Capacity-Load Balancing

- ◆ Dynamic charts provide early warning
- ◆ Overload alerts -> drill-down analysis
- ◆ Identify flights contributing to load
- ◆ Trial cumulative “what-if” flow initiatives
- ◆ Graphical re-routes
- ◆ Rewind/Undo facility

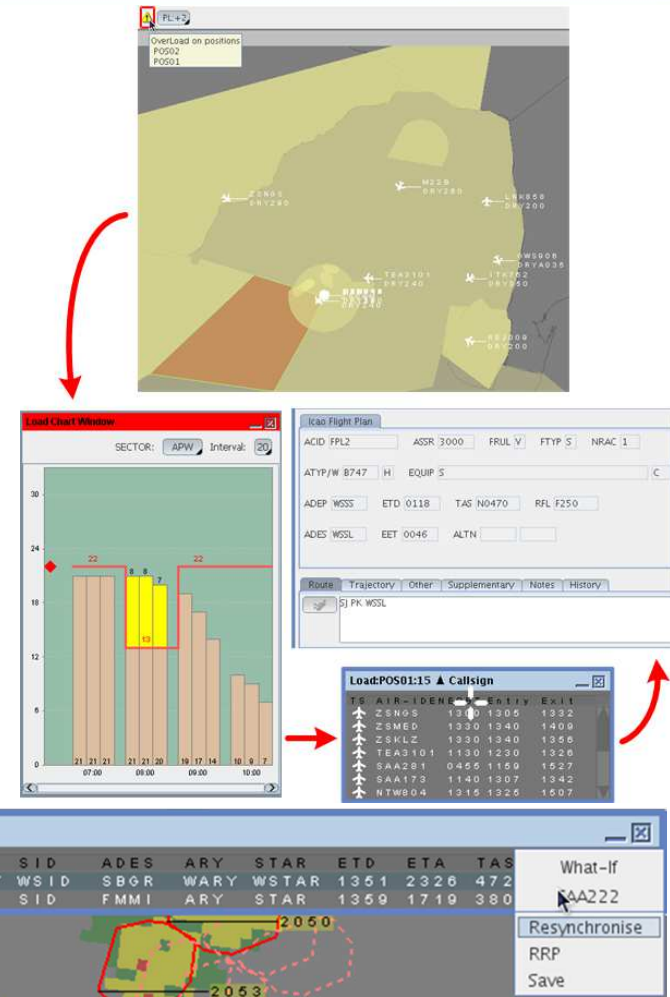

Capacity Management → Complexity / Workload

Dynamic Airspace Management

- ◆ Implement Flexible Use of Airspace and Civil-Military Co-ordination
- ◆ Create Temporary Segregated Areas & model the effect on traffic load
- ◆ Dynamic Sectorisation - I (sectorisation plan) & II (sector geometry)

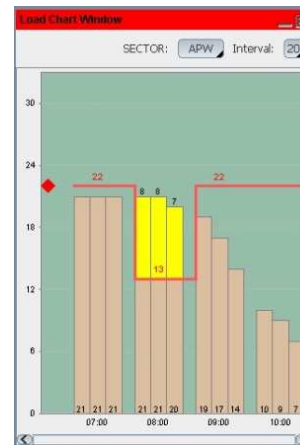
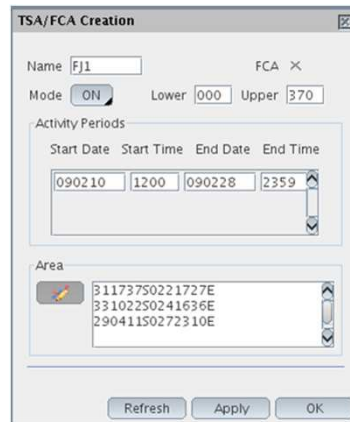
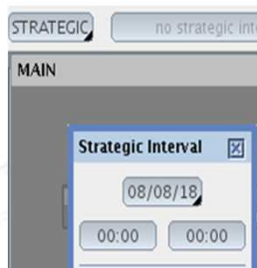

ROOM	Layout	LFUNC	POS
LS1			
LS2			
LS3			
LS4	POS01	EC	AJF APS APW
LS5	POS02	EC	SWE
LS6	POS03	EC	
LS7	POS04	PLC	SWE SEA NTH
LS8	POS05	EC	
LS9	POS06	PLC	
	POS07	EC	

Capacity Management → Complexity / Workload

Benefits of AMAN/DMAN

◆ AMAN

- Increased Runway Capacity (+10%) and Approach Capacity (+30%)
- Improved Predictability and Punctuality
- Improved Flight Efficiency (less holding leading to fuel and emissions savings)
- Enabler for Performance Based Operations (CDO, RNP-AR, ...)

◆ DMAN

- Increased Runway Capacity (+5%)
- Improved Predictability and Punctuality
- Improved Flight Efficiency (reduced taxi-time leading to fuel and emissions savings)
- Enabler for Airport CDM Operations

The Expanding MAESTRO AMAN/DMAN Horizon

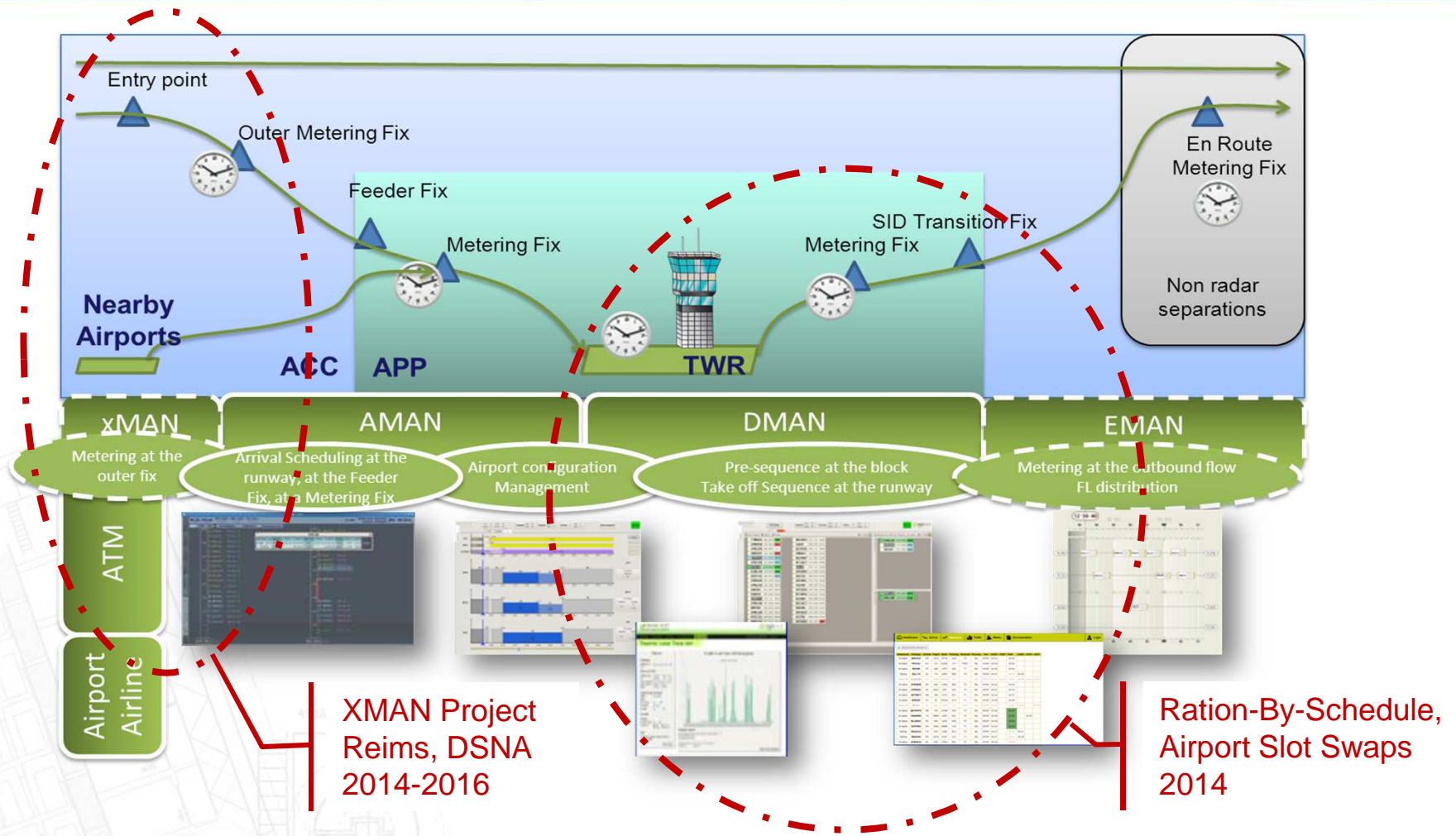

Sequencing horizon extending 2-3 hours ahead

THALES

SMARTER | SAFER

Combined AMAN/DMAN → Multi-Nodal ATFM

◆ Closely-spaced arrival and departure airports

- DMAN and AMAN co-ordinate departures at one airport with arrivals at the other

◆ Closely-spaced arrival airports

- AMAN sequences several airports in TMA through common or different feeder fixes

◆ Closely-spaced departure airports with common exit fixes

- DMAN systems synchronise with each other to achieve a common departure stream

◆ Farther-spaced city pairs (national or international)

- XMAN serves as intermediary between AMAN & DMAN systems

Tactical implementation multi-FIR Ground Delay Program

MAESTRO XMAN

- ◆ FABEC/SESAR Reims project
- ◆ Meter and display traffic entering UK airspace through ABNUR
 - Hand over to AMAN in TMA
- ◆ Share delay amongst LTCC, LACC and Reims UAC
 - Upper Airspace; Transit Traffic
- ◆ Speed advisories computed according to various strategies
- ◆ Web-services based architecture

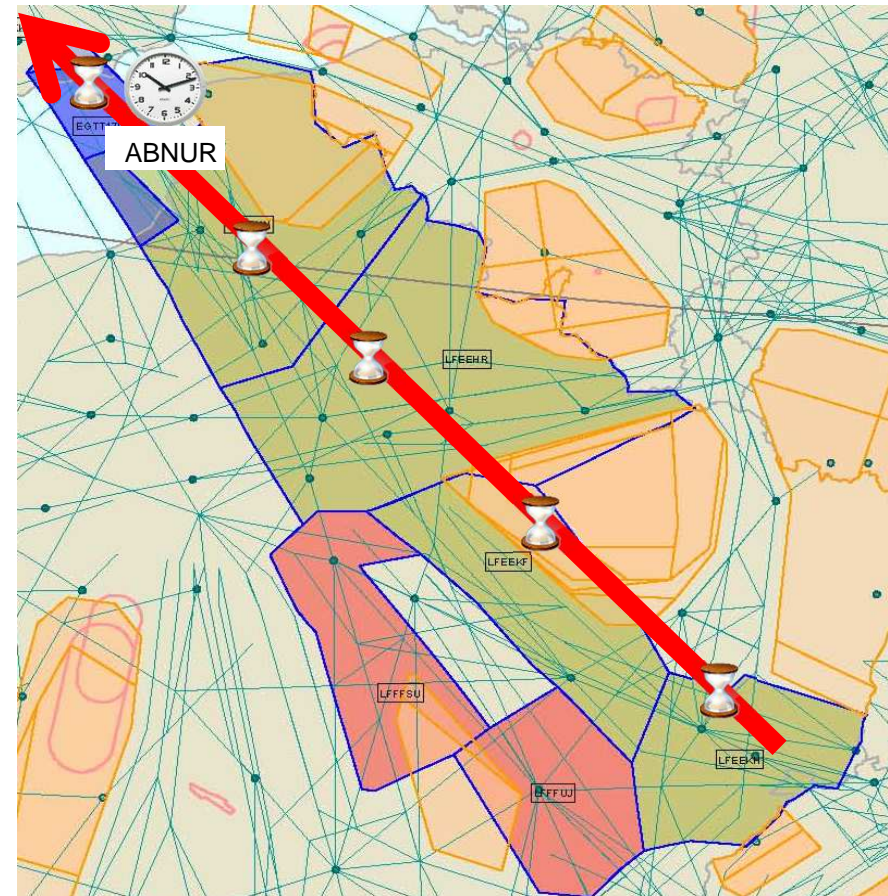

Benefits of Advanced Weather Services

◆ Airlines

- Trajectory optimisation in both nominal and adverse weather
- Improved MET prediction leading to less contingency fuel & improved flight comfort
- Improved punctuality

◆ ATC/ATFM

- Improved utilisation of airspace in adverse weather
- More predictable weather deviation re-routes and durations
- Reduction in ATCO workload through the anticipation of complexity

Weather is a major disruptive factor in operations

Leveraging the expertise gained on TOPMET

- ◆ **TOPMET is a SESAR demonstration project led by Thales**
 - Decision Support tool for Traffic Flow Managers and Flight Dispatchers
 - Tablet-based Situational Awareness app for Pilots
 - Uses a prototype 4D Weather Cube & new MET services
- ◆ **TopSky-ATC extracts MET data from ADS-B and ADS-C reports**
 - Position, Altitude, Time, Wind Speed & Direction, Temp, Turbulence (if available)
 - Exported to external systems (XML) for potential use in a 4D Weather Cube

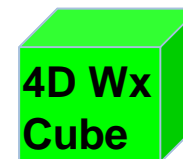
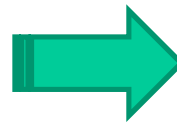
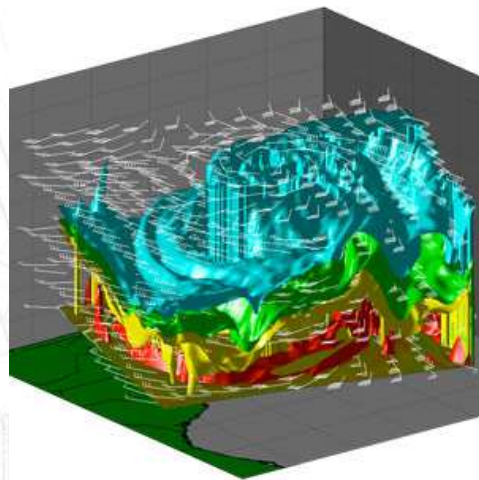

TOPMET-based HMI

◆ Layers

- Aeronautical Info
- MET Information
- ATC Sector Capacity



◆ Decision Aids

- MET-impact Sector Scoring
- Automatic Warning
- What-if, Short Term ATFM Measures

ATC	SID/STAR	COM/ACDG	SID	STAR
Time	2012-09-25 14:15		ATREX SA 3D - RWY 27L P9276-ATREX 387FL ATREX 39 3E - RWY 20R P9255-ATREX 412FL	DPE SW - RWY 26L 27R 27L 27R DPE RWY 362FL DVL SP - RWY 26L 26R 27L 27R HEREN-RDU 312FL

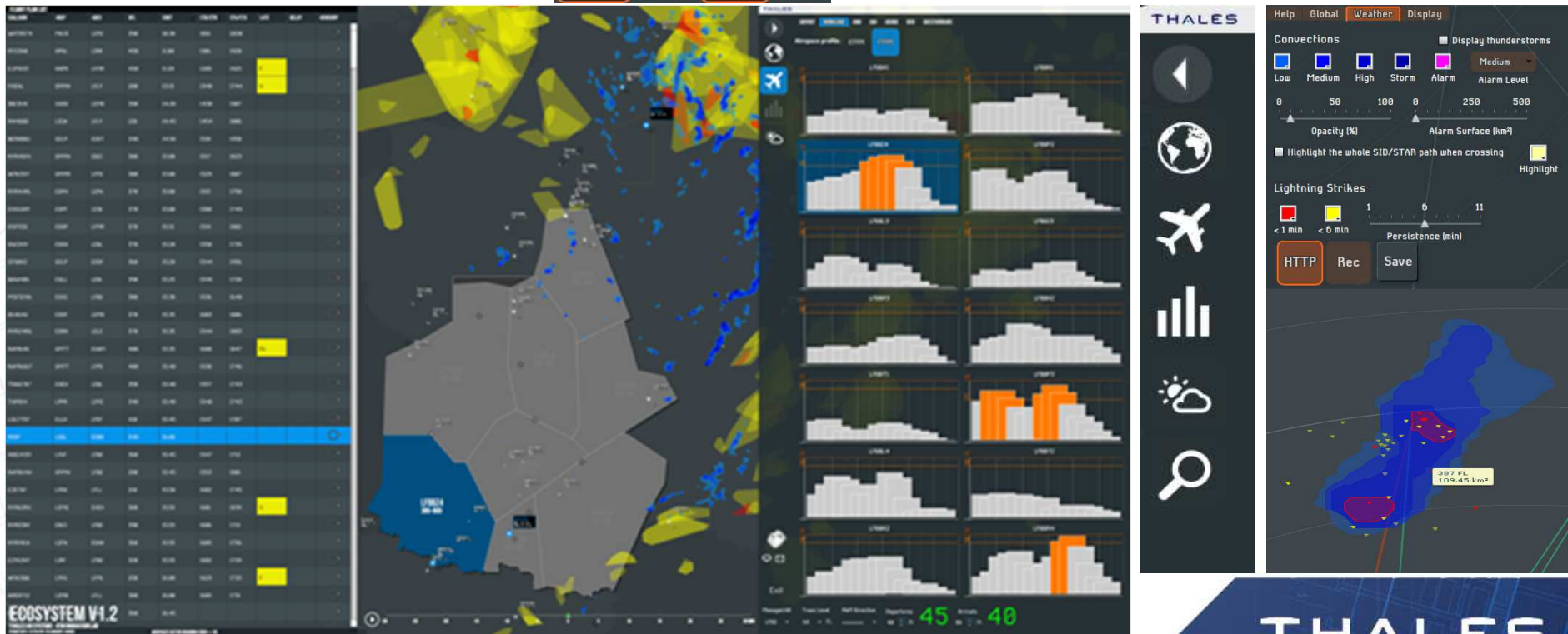

THALES
SMARTER | SAFER

Complexity Measures

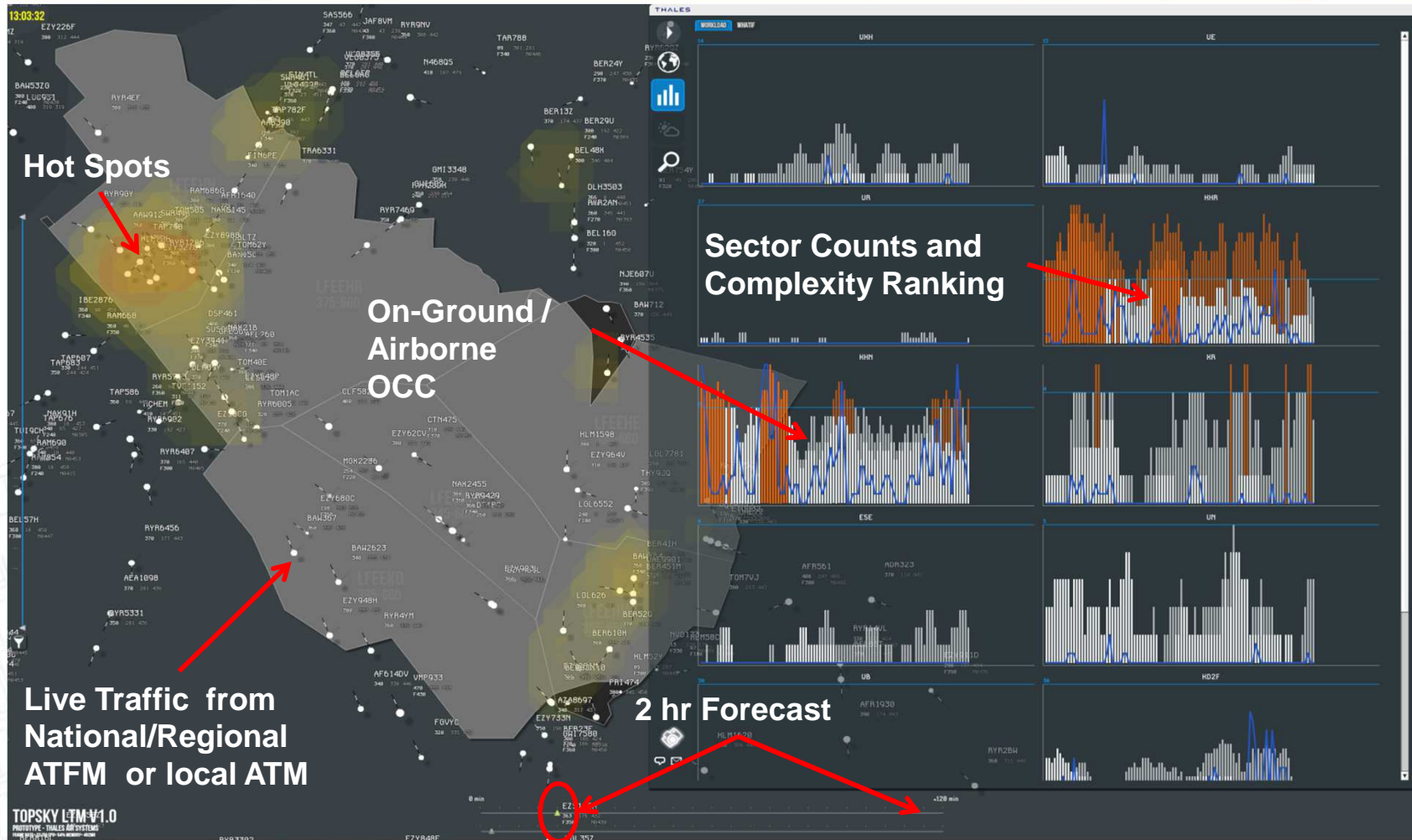

Researching advanced complexity algorithms with DSN

THALES

SMARTER | SAFER

The Link by Thales

- ◆ **A new innovation lab linking Thales Avionics and ATM systems**
 - End-to-end simulation: SESAR, NextGen, ASBU concepts & next-gen Datalink
 - Demonstrate the benefits of new technology and solutions to all stakeholders: Airlines, Airports, ANSPs, Pilots & Air Frame Builders
 - Includes Thales initiative to better involve Airlines in the overall process



Regional ATFM Organisational Structures Contrasted

Europe – SESAR Proposal for Regional ATFM Structure

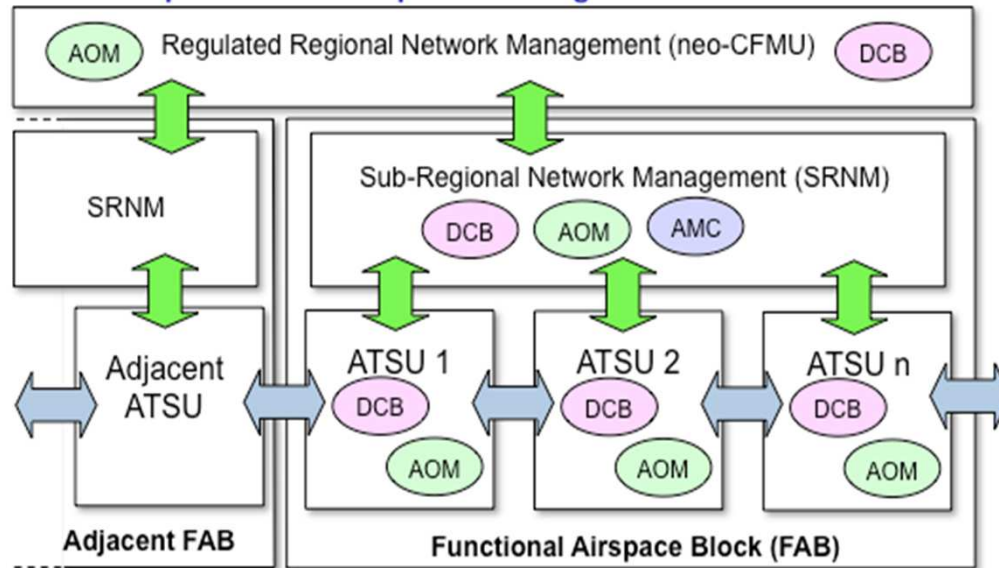

Asia-Pacific – One Possible Regional ATFM Structure

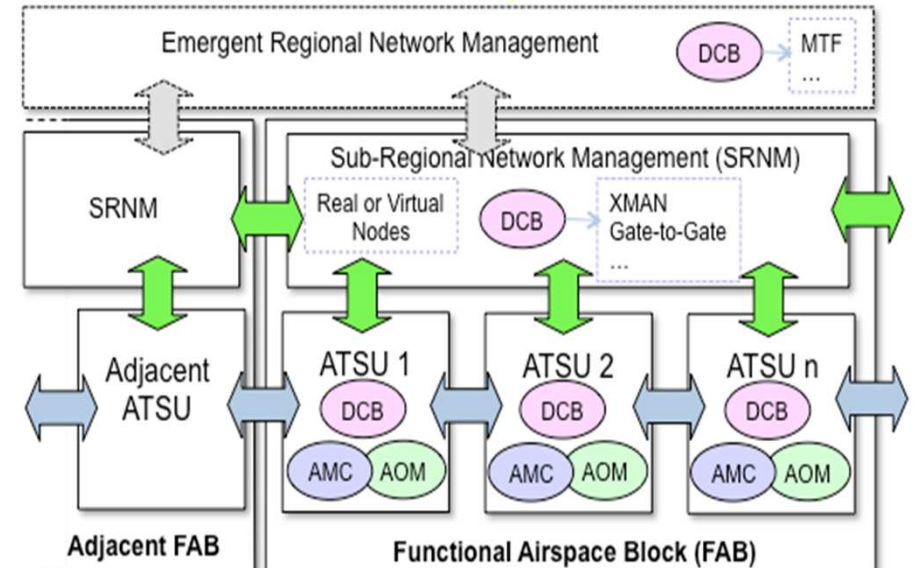

- AOM: Airspace Organisation & Management
- AMC: Airspace Management Cell
- ATSC: Air Traffic Services Unit

- DCB: Dynamic Capacity Balancing
- MTF: Major Traffic Flow
- XMAN: Enroute Pre-Sequencer

- ◆ Virtual ATFM Nodes enabled by CDM Technologies: Web-Services, SWIM ...

Which function where? By whom? With whom?

One Possible Regional ATFM Concept

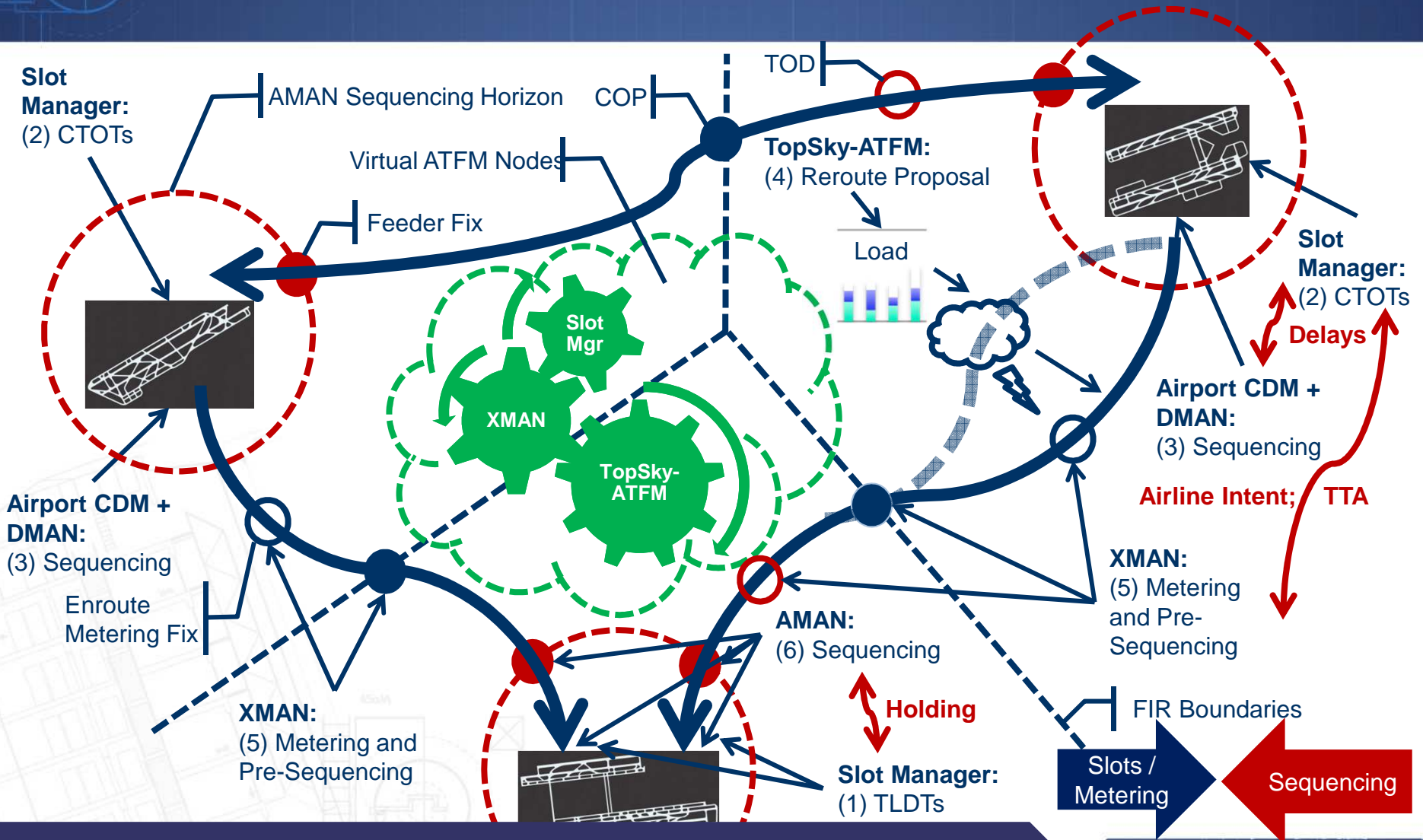

Which tool where? Which technique when?

THALES

SMARTER | SAFER

Conclusion: TopSky-ATFM Generation II

- ◆ **Regional multi-nodal ATFM concepts are emerging**
- ◆ **In response Thales is integrating recent ATFM functionality from**
 - Latest TopSky-ATC baseline (includes TopSky-ATFM Generation I functions)
 - Acquired Egis Avia sequencing tools
 - Expertise from SESAR/FABEC projects and internal R&D
 - Establishment of “The Link” laboratory
- ◆ **To provide a 2nd Generation ATFM offering for our customers**
 - Integrated Multi-Nodal Sequencing: AMAN, DMAN, XMAN
 - Advanced 4D Trajectory Computation and What-if DCB Modelling
 - Advanced Complexity Algorithms and Weather Services
 - Distributed, Web-based HMI
 - Thales and 3rd-party Web Services

Tactical ATFM: measures at one node impact other nodes

Questions



The background is a dark blue grid with faint white technical drawings. On the left, there's a perspective view of a building's structural frame. On the right, there's a circular technical drawing with various lines and a small 'x' mark. At the bottom, there are more technical drawings, including a cross-section of a structure and a ladder-like element.

THALES

SMARTER | SAFER

THANK YOU