



International
Civil Aviation
Organization

Organisation
de l'aviation civile
internationale

Organización
de Aviación Civil
Internacional

Международная
организация
гражданской
авиации

منظمة الطيران
المدني الدولي

国际民用
航空组织

Tel.: +1 (514) 954-8219 ext. 6718

Ref.: SP 65/4-13/24

14 June 2013

Subject: Proposal for the amendment of PANS-OPS, Volumes I and II regarding procedure design criteria and charting requirements to support performance-based navigation (PBN) as well as helicopter point-in-space (PinS) approach and departure operations with consequential amendments to Annexes 4; 6, Parts I, II and III; 14, Volume II; 15 and the PANS-ABC

Action required: Comments to reach Montréal by 30 September 2013

Sir/Madam,

1. I have the honour to inform you that the Air Navigation Commission, at the tenth meeting of its 192nd Session on 7 March 2013 and the twelfth meeting of its 193rd Session on 4 June 2013, considered proposals developed by the Instrument Flight Procedures Panel (IFPP) seventh, eighth, ninth, tenth and eleventh working group of the whole meetings to amend the *Procedures for Air Navigation Services — Aircraft Operations*, Volume I — *Flight Procedures* and Volume II — *Construction of Visual and Instrument Flight Procedures* (PANS-OPS, Doc 8168) with consequential amendments to Annex 4 — *Aeronautical Charts*; Annex 6 — *Operation of Aircraft*, Part I — *International Commercial Air Transport — Aeroplanes*, Part II — *International General Aviation — Aeroplanes* and Part III — *International Operations — Helicopters*; Annex 14 — *Aerodromes*, Volume II — *Heliports*; Annex 15 — *Aeronautical Information Services; Procedures for Air Navigation Services — ICAO Abbreviations and Codes* (PANS-ABC, Doc 8400) regarding flight procedure design criteria and associated charting requirements for performance-based navigation (PBN), in particular for the new navigation specifications as well as for helicopter point-in-space (PinS) approach and departure operations.

2. The proposed amendment to PANS-OPS, Volumes I and II are in Attachments B and C, respectively. Consequential amendments to Annexes 4; 6, Parts I, II and III; 14, Volume II; 15 and the PANS-ABC are in Attachments D to H, respectively.

3. The amendment proposals address specific areas as listed and explained in Attachment A.

4. To facilitate your review of the proposed amendments, the rationale for each proposal has been provided in the text boxes immediately following the proposals throughout Attachments B, C, D, E, F, G and H.

5. In examining the proposed amendment, you should not feel obliged to comment on editorial aspects as such matters will be addressed by the Air Navigation Commission during its final review of the draft amendment.

6. May I request that any comments you may wish to make on the proposed amendment to the PANS-OPS, Volumes I and II, Annexes 4; 6, Parts I, II and III; 14, Volume II; 15; and the PANS-ABC be dispatched to reach me not later than 30 September 2013. The Air Navigation Commission has asked me to specifically indicate that comments received after the due date may not be considered by the Commission and the Council. In this connection, should you anticipate a delay in the receipt of your reply, please let me know in advance of the due date.

7. The amendment regarding the conversion of area navigation (RNAV) approach procedure depiction to required navigation performance (RNP) in the PANS-OPS, Volume II is required to align charts with the PBN navigation specifications thereby reducing confusion on operation approvals and flight planning requirements. A one-step eight-year transition period, starting 13 November 2014, is being proposed to allow States sufficient time to develop a transition plan and to convert the existing RNAV approach procedures to RNP by 2022. ICAO will issue a new circular (Circ 336 — *Circular on Conversion of RNAV to RNP Approach Chart Depiction*) which will provide guidance to States on what should be considered in their transition planning. This circular will be available in the fourth quarter of 2013 and an executive summary is contained in Appendix I.

8. In addition, the proposed amendment to PANS-OPS, Volumes I and II along with the consequential amendments to Annexes 4; 6, Parts I, II and III; 14, Volume II; 15; and the PANS-ABC are envisaged for applicability on 13 November 2014. Any comments you may have thereon would be appreciated.

9. The subsequent work of the Air Navigation Commission and the Council would be greatly facilitated by specific statements on the acceptability or otherwise of the amendment proposal.

10. Please note that, for the review of your comments by the Air Navigation Commission and the Council, replies are normally classified as “agreement with or without comments”, “disagreement with or without comments”, or “no indication of position”. If in your reply the expressions “no objections” or “no comments” are used, they will be taken to mean “agreement without comment” and “no indication of position”, respectively. In order to facilitate proper classification of your response, a form has been included in Attachment J which may be completed and returned together with your comments, if any, on the proposals in Attachments B to H.

Accept, Sir/Madam, the assurances of my highest consideration.



Raymond Benjamin
Secretary General

Enclosures:

- A — Background
- B — Proposed amendment to the PANS-OPS, Volume I
- C — Proposed amendment to PAN-OPS Volume II
- D — Proposed amendment to Annex 4
- E — Proposed amendment to Annex 6, Parts I, II and III
- F — Proposed amendment to Annex 14, Volume II
- G — Proposed amendment to Annex 15
- H — Proposed amendment to the PANS-ABC
- I — Executive summary of ICAO Circular 336
- J — Response Form

BACKGROUND

The amendment proposals to the PANS-OPS, Volumes I and II and consequential amendments to Annexes 4; 6, Parts I, II and III; 14, Volume I; 15 and the PANS-ABC address the following specific areas:

1. *PBN – Charting*: Inconsistencies with the aeronautical charts, the PBN operational approvals, and the avionics displays have created confusion. The rationalization of procedure identification detailed in this amendment addresses the issue and provides a simpler and clearer method for procedure naming and a standardized approach to aeronautical charting. Another element of this proposal includes a standard depiction of magnetic bearings on PBN routes;
2. *PBN – Support for new navigation specifications*: Supports the introduction of four new navigation specifications and various new functional requirements in the *Performance-based Navigation (PBN) Manual* (Doc 9613) by the inclusion of appropriate PBN design criteria in the PANS OPS;
3. *PBN – Baro-vertical navigation (Baro-VNAV)*: Following the publication of the Baro-VNAV attachment in the PBN Manual and the operational experience gained since the first release of the Baro-VNAV criteria in the PANS-OPS, these criteria have been reviewed and made consistent with the PBN Manual as well as with other vertically guided approaches using satellite-based augmentation systems (SBAS) and precision landing system such as instrument landing system (ILS). This will result in less complex design requirements and less conservative minima which will benefit the implementation of approach procedure with vertical guidance (APV) procedures. It also addresses an inconsistency in the criteria for aerodromes above 5 000 ft;
4. *PBN – Satellite-based augmentation system/ground-based augmentation system (SBAS/GBAS)*: Amendment 85 to ICAO Annex 10 — *Aeronautical Telecommunications* introduced the SBAS signal in space performance requirements for Cat I precision approach operations which will provide improved accessibility through lower minima. To facilitate implementation, this consequential amendment updates the PANS-OPS to reflect these improved performance requirements;
5. *Continuous descent/climb operations (CDO/CCO)*: The PANS-OPS is currently not very clear on permitting the use of a continuous vertical glide path in the intermediate segment and therefore could be counterproductive in supporting the implementation of CDO/CCO's. This proposed amendment addresses the issue and updates the PANS-OPS;
6. *Helicopter*: Current helicopter instrument procedure design criteria do not incorporate the use of vertical guidance that is available today through space-based systems nor does it allow for the design of instrument departures to re-join the IFR en route structure. This amendment addresses both of these deficiencies; and
7. *Miscellaneous topics*: Include clarification of the frame of reference to be used for procedure design and the alignment of the PANS-OPS and Annex 14 requirements in the approach phase.

— — — — —

PROPOSED AMENDMENT TO PANS-OPS, VOLUME I

NOTES ON THE PRESENTATION OF THE AMENDMENT

1. The text of the amendment is arranged to show deleted text with a line through it and new text highlighted with grey shading, as shown below:

~~Text to be deleted is shown with a line through it.~~

text to be deleted

New text to be inserted is highlighted with grey shading.

new text to be inserted

~~Text to be deleted is shown with a line through it~~ followed by the replacement text which is highlighted with grey shading.

new text to replace existing text

**TEXT OF THE PROPOSED AMENDMENT TO
PROCEDURES FOR AIR NAVIGATION SERVICES
AIRCRAFT OPERATIONS
VOLUME I — FLIGHT PROCEDURES**

PBN — CHARTING

**Part I
FLIGHT PROCEDURES — GENERAL**

...

**Section 4
ARRIVAL AND APPROACH PROCEDURES**

...

**Chapter 8
CHARTING/AERONAUTICAL INFORMATION PUBLICATION (AIP)**

...

8.5 PROCEDURE NAMING FOR ARRIVAL AND APPROACH CHARTS

8.5.1 Instrument flight procedure naming convention

8.5.1.1 This paragraph describes the general aspects of instrument procedure naming. Specific aspects are covered in the appropriate chapters. A standardized naming convention is required to avoid ambiguity between charts, electronic cockpit displays and ATC clearances. This convention affects the following charting aspects:

- a) procedure identification;
- b) additional equipment requirements; and
- c) minimum boxes.

Note.— Procedure naming requirements for PBN arrivals and approaches are contained in PANS-OPS, Volume II, Part III, Section 5, Chapter 1.

...

Part II
FLIGHT PROCEDURES — RNAV AND SATELLITE-BASED

...

Section 7
EN ROUTE

Chapter 1
AREA NAVIGATION (RNAV) AND RNP-BASED
EN-ROUTE PROCEDURES

...

1.3 MAGNETIC BEARING ON A
PBN (RNAV OR RNP) ROUTE SEGMENT

1.3.1 The magnetic bearing for a PBN route segment is based on the true course and the magnetic variation at the significant point at origin of the PBN route segment.

1.3.2 Pilots should use the magnetic bearing as reference only, because their navigation system will fly the true course from one significant point to another. When a PBN route overlays an existing airway (joint conventional and PBN route) the magnetic bearing of the PBN route segment is not charted. In this case, the VOR radial or the NDB magnetic bearing is charted.

...

<i>Origin:</i> <i>IFPP / Secretariat</i>	<i>Rationale</i> Inconsistencies with the charts, the PBN approvals and avionics displays have created confusion. The rationalization of procedure identification detailed in this amendment addresses the issue and provides a simpler and clearer method for procedure naming and a standardized approach to charting. Another element of this proposal concerns that there is no standard concerning the depiction of magnetic bearings on RNAV routes. This may result in a disparity between what is provided on the chart and what is displayed to pilots. This amendment will harmonize the charted and displayed magnetic directional values which can be expected upon rollout after passing a significant point on a PBN route. This will improve situational awareness and provide a means to cross-check the airborne data.
---	---

CDO/CCO

**Part I
FLIGHT PROCEDURES — GENERAL**

**Section 1
DEFINITIONS, ABBREVIATIONS AND ACRONYMS
AND UNITS OF MEASUREMENT**

...

**Chapter 1
DEFINITIONS**

...

Continuous climb operation (CCO). An operation, enabled by airspace design, procedure design and ATC, in which a departing aircraft climbs continuously, to the greatest possible extent, by employing optimum climb engine thrust and climb speeds until reaching the cruise flight level.

Continuous descent operation (CDO). An operation, enabled by airspace design, procedure design and ATC, in which an arriving aircraft descends continuously, to the greatest possible extent, by employing minimum engine thrust, ideally in a low drag configuration, prior to the final approach fix /final approach point.

...

**Chapter 2
ABBREVIATIONS AND ACRONYMS**

...

ATM Air traffic management
CCO Continuous climb operation
CDO Continuous descent operation

...

**Section 4
ARRIVAL AND APPROACH PROCEDURES**

...

**Chapter 4
INTERMEDIATE APPROACH SEGMENT**

4.1 GENERAL

4.1.1 Purpose

This is the segment during which the aircraft speed and configuration should be adjusted to prepare the aircraft for final approach. For this reason, the designed descent gradient is kept as shallow as possible. To fly an efficient descent profile the pilot may elect to configure the aircraft whilst in a continuous descent along this segment.

...

**Section 7
NOISE ABATEMENT PROCEDURES**

...

**Chapter 3
AEROPLANE OPERATING PROCEDURES**

3.1 INTRODUCTION

3.1.1 This chapter provides guidance with regard to aeroplane noise-mitigating measures associated with the development and/or application of departure climb, approach, and landing procedures and the use of displaced runway thresholds. CCO and CDO can enhance safety, capacity and efficiency and should be considered in order to benefit the environment (emissions and noise) (see *Continuous Climb Operations (CCO) Manual* (Doc 9993) and *Continuous Descent Operations (CDO) Manual* (Doc 9931)).

<i>Origin:</i> <i>IFPP / Secretariat</i>	<i>Rationale</i> CDO and CCO provide significant fuel efficiency and environmental benefits. Recently, new manuals have been published that provide guidance on how to implement CDO and CCO as an integral part of an airspace concept. The PANS-OPS is currently not very clear on permitting the use of a continuous vertical glide path in the intermediate segment and could therefore be counterproductive in supporting the implementation of CDO/CCO's. This proposed amendment addresses the issue and updates the PANS-OPS.
---	--

HELICOPTERS

Part I FLIGHT PROCEDURES — GENERAL

Section 1 DEFINITIONS, ABBREVIATIONS AND ACRONYMS AND UNITS OF MEASUREMENT

...

Chapter 1 DEFINITIONS

...

Descent point (DP). A point defined by track and distance from the MAPt to identify the point at which the helicopter may descend below the OCA/H on a visual descent to the heliport or landing location.

...

Direct visual segment (Direct-VS). ~~The portion of flight that connects the PinS to the landing location; this can be either direct to the landing location or via a descent point (DP) where a limited track change may occur.~~ A visual segment designed as:

- a leg in a PinS approach, which may contain a single turn, from the MAPt direct to the heliport or landing location or via a descent point, to the heliport or landing location; or
- a straight leg from the heliport or landing location to the IDF in a PinS departure.

...

Height above surface (HAS). The difference in height between the OCA and the elevation of the highest terrain, water surface or obstacle within a radius of at least 1.5 km (0.8 NM) from the MAPt in a PinS 'Proceed VFR' procedure.

...

Heliport reference point (HRP). The designated location of a heliport or a landing location.

...

Initial departure fix (IDF). The terminal fix for the visual segment and the fix where the instrument phase of the PinS departure begins.

...

Landing location. A marked or unmarked landing area that has the same physical characteristics as a non-instrument heliport as per Annex 14, Volume II. (e.g.: the landing location could be a non-

instrument heliport or could be located on a non-instrument runway.) visual heliport final approach and take-off area (FATO).

...

Manoeuvring visual segment (Manoeuvring-VS). PinS visual segment protected for the following manoeuvres for:

- *PinS approaches:* visual manoeuvre from the MAPt around the heliport or landing location to land from a direction other than directly from the MAPt.
- *PinS departures:* take-off in a direction other than directly to the IDF followed by visual manoeuvre to join the instrument segment at the IDF.

...

Minimum instrument meteorological conditions airspeed (V_{mini}). The minimum indicated airspeed that a specific helicopter is certified to operate in instrument meteorological conditions.

...

Minimum sector altitude (MSA). The lowest altitude which may be used which will provide a minimum clearance of 300 m (1 000 ft) above all objects located in an area contained within a sector of a circle of 46 km (25 NM) radius centred on a radio-aid-to-navigation-significant point, the aerodrome reference point (ARP), or the heliport reference point (HRP).

...

Obstacle clearance altitude (OCA) or obstacle clearance height (OCH). The lowest altitude or the lowest height above the elevation of the relevant runway threshold or the aerodrome elevation as applicable, used in establishing compliance with appropriate obstacle clearance criteria.

...

Note 4.— See PANS-OPS, Volume II, Part IV, Chapter 2, for area navigation (RNAV) point-in-space (PinS) approach procedures for helicopters using basic GNSS receivers.

...

Point-in-space (PinS) approach. ~~The point in space approach is based on a basic GNSS non-precision~~ An approach procedure designed for helicopters only that includes both a visual and an instrument segment. ~~It is aligned with a reference point located to permit subsequent flight manoeuvring or approach and landing using visual manoeuvring in adequate visual conditions to see and avoid obstacles.~~

Point-in-space (PinS) departure. A departure procedure designed for helicopters only that includes both a visual and an instrument segment.

...

Point-in-space (PinS) visual segment. ~~This is the~~ The segment of a helicopter PinS approach procedure ~~from the MAPt to~~ between a point (MAPt or IDF) and the heliport or the landing location ~~for a PinS “proceed visually” procedure.~~

...

Visual segment design gradient (VSDG). The gradient of the visual segment in a PinS departure procedure. The visual segment connects the heliport or landing location with the initial departure fix (IDF) minimum crossing altitude (MCA).

...

Chapter 2 ABBREVIATIONS AND ACRONYMS

Editorial note.— Insert new abbreviations as follows:

Direct – VS Direct visual segment

HCH Heliport crossing height

IDF Initial departure fix

Manoeuvring-VS Manoeuvring visual segment

MCA Minimum crossing altitude

V_{mini} Minimum instrument meteorological conditions airspeed

VSDG Visual segment design gradient

End of new text.

...

**Section 4
ARRIVAL AND APPROACH PROCEDURES**

**Chapter 1
GENERAL CRITERIA FOR
ARRIVAL AND APPROACH PROCEDURES**

...

*Editorial note.— Amend Tables I-4-1-1 and
I-4-1-2, note “***” as follows:*

Table I-4-1-1. Speeds for procedure calculations in kilometres per hour (km/h)

...

*** Helicopter point-in-space procedures based on basic GNSS may be designed using maximum speeds of 220 km/h for initial and intermediate segments and 165 km/h on final and missed approach segments, or 165 km/h for initial and intermediate segments and 130 km/h on final and missed approach segments based on depending on the operational need. Refer to PANS-OPS, Volume II, Part IV, Chapter 4 2, “Area navigation (RNAV) point-in-space (PinS) approach procedures for helicopters using basic GNSS receivers”.

...

Table I-4-1-2. Speeds for procedure calculations in knots (kt)

...

*** Helicopter point-in-space procedures based on basic GNSS may be designed using maximum speeds of 120 KIAS for initial and intermediate segments and 90 KIAS on final and missed approach segments, or 90 KIAS for initial and intermediate segments and 70 KIAS on final and missed approach segments based on depending on the operational need. Refer to PANS-OPS, Volume II, Part IV, Chapter 4 2, “Area navigation (RNAV) point-in-space (PinS) approach procedures for helicopters using basic GNSS receivers”.

...

**Section 8
PROCEDURES FOR USE
BY HELICOPTERS**

...

Editorial note.— Delete Chapter 4 in toto and replace by the following new Chapter 4.

**Chapter 4
HELIPORT DEPARTURE PROCEDURES**

**4.1 HELICOPTER DEPARTURES FROM
INSTRUMENT HELIPORTS OR LANDING LOCATIONS**

(To be developed)

**4.2 HELICOPTER POINT-IN-SPACE (PinS) DEPARTURES
FROM HELIPORTS OR LANDING LOCATIONS**

4.2.1 PinS departure – General

4.2.1.1 The PinS departure consists of a visual segment followed by an instrument segment. The visual phase of flight starts from the heliport or landing location and ends at the initial departure fix (IDF) at or above the IDF minimum crossing altitude (MCA). Flight manoeuvring from the heliport or landing location to the IDF, where the helicopter transitions from the visual segment to the instrument segment flight, assumes adequate visual conditions for the pilot to see and avoid obstacles.

4.2.1.2 The IDF is identified by a fly-by waypoint. If the IDF cannot be identified visually, the GNSS navigation system may be used to identify the IDF location and to provide directions to it.

4.2.1.3 A PinS departure procedure includes either a “proceed VFR” or “proceed visually” instruction from the heliport or landing location to the IDF:

- a) *For PinS departure with a “proceed VFR” instruction*, no obstacle protection is provided from the landing location to the IDF. The pilot shall remain in VFR conditions to see and avoid obstacles in this part of the flight up to the IDF, at or above the MCA. PinS departures with a “proceed VFR” instruction can serve multiple heliports or landing locations.
- b) *For PinS departure with a “proceed visually” instruction*, a visual manoeuvring area is identified from a single heliport or landing location to the IDF and obstacle protection is provided within this area. Pilots shall navigate by visual reference to the surface and the visibility shall be sufficient to see and avoid obstacles and to return to the heliport or landing location if it is not possible to continue visually to cross the IDF at or above the IDF MCA.

4.2.1.4 After passing the IDF, instrument departure criteria provide obstacle protection. The following requirements apply to entry of the instrument flight structure at the IDF:

- a) For PinS departure with a “proceed VFR” instruction, the helicopter shall depart from the heliport or landing location and fly VFR until crossing the IDF at or above the IDF MCA. An IFR clearance shall be obtained prior to reaching the IDF.
- b) For a PinS departure with a “proceed visually” instruction, the helicopter shall depart on an IFR clearance from the heliport or landing location and fly visually until crossing the IDF at or above the IDF MCA.

4.2.2 Instrument phase of the PinS departures

4.2.2.1 *Application of PBN.* The instrument segment of the departure procedure is based on the applicable PBN navigation specifications.

4.2.2.2 *Instrument Phase.* The instrument flight phase starts when the helicopter crosses the IDF. The instrument phase consists of one or more segments and continues until the minimum en-route altitude is reached.

4.2.2.3 *Procedure design gradient (PDG).* The standard PDG is 5 per cent. The PDG originates from the IDF MCA. Steeper PDGs are permitted when operationally required.

4.2.3 Visual segment for a PinS departure with “proceed visually” instruction

4.2.3.1 The visual segment for a PinS departure with a “proceed visually” instruction can be either a direct visual segment (Direct-VS) or a manoeuvring visual segment (Manoeuvring-VS).

4.2.3.2 Direct visual segment

4.2.3.2.1 *Track change at the IDF.* The visual segment shall be flown directly from the heliport or landing location to the IDF.

4.2.3.2.2 *Visual segment design gradient (VSDG).* The standard VSDG is 5 per cent.

4.2.3.3 Manoeuvring visual segment

4.2.3.3.1 A manoeuvring visual segment is protected for a take-off in a direction other than directly to the IDF and a visual manoeuvre to join the initial instrument phase segment at the IDF.

4.2.3.3.2 The visual manoeuvre shall be conducted as follows:

- a) initially climb on the centre line of the take-off climb surface to reach the greater of the following two heights, before manoeuvring toward the IDF:
 - 1) minimum crossing height (MCH)/2;

- 2) 90 m (295 ft) above the heliport/landing location elevation; and
- b) continue to climb and accelerate so as to cross the IDF at or above the MCA.

4.2.4 Visual segment for a PinS departure with a “proceed VFR” instruction

4.2.4.1 The visual segment of the PinS departure with a “proceed VFR” instruction is based on State regulatory requirements for VFR operations. No obstacle protection is provided from the heliport or landing location to the IDF.

4.2.4.2 The pilot shall remain in VFR conditions to see and avoid obstacles in this part of the flight up to the IDF, at or above the MCA. PinS departures with “proceed VFR” instruction can serve multiple heliports or landing locations in a prescribed area that use a common instrument segment.

4.2.5 Promulgation

4.2.5.1 PinS departure chart designation includes “RNAV XXXXX” where XXXXX is the name of the last waypoint in the departure procedure. PinS departure procedures are annotated “proceed visually” or “proceed VFR”. The plan view shall include a note that the procedure is Cat H only.

4.2.5.2 VSDGs steeper than 5 per cent are charted.

End of new Chapter 4.

Editorial note.— Insert new Chapter 5 as follows:

Chapter 5 PBN POINT-IN-SPACE (PinS) APPROACH PROCEDURES

5.1 PinS APPROACH OPERATIONS CHARACTERISTICS

5.1.1 General

5.1.1.1 A PinS approach is an instrument RNP APCH procedure flown to a point-in-space. It may be published with LNAV minima or LPV minima. The PinS approach procedure includes either a “proceed visually” instruction or a “proceed VFR” instruction from the MAPt to the heliport or landing location. This is further detailed in 5.1.2 and 5.1.3, respectively.

Note.— PinS instrument approach procedures with LNAV minima may be flown using a continuous descent final approach technique (CDFA). CDFA with manual calculation of the required rate of descent are considered 2D instrument approach operations. For more information on CDFA refer to Section 4, 1.7 and 1.8.

5.1.1.2 Obstacle clearance is provided for all IFR segments of the procedure including the missed approach segment based on the corresponding protection criteria. For a PinS RNP APCH with LNAV minima, the pilot shall initiate a missed approach, if needed, at or prior to the MAPt. For a PinS RNP APCH with LPV minima the pilot shall initiate a missed approach, if needed, at or prior to the point where the DA/H is reached or the MAPt, whichever occurs first. Flight manoeuvring beyond the MAPt assumes adequate visual conditions to see and avoid obstacles.

5.1.2 PinS approach procedure with “proceed visually” instruction

5.1.2.1 A PinS approach with a “proceed visually” instruction is an instrument approach procedure developed for a heliport or a landing location. The PinS instrument approach segment delivers the helicopter to a MAPt. A visual segment connects the MAPt to the heliport or landing location, by a direct visual segment or a manoeuvring visual segment. If the heliport or landing location or visual references associated with it can be acquired visually prior to the MAPt, the pilot may decide to proceed visually to the heliport or landing location otherwise a missed approach shall be executed.

5.1.2.2 The minimum visibility is based on the distance from the MAPt to the heliport or landing location. IFR obstacle clearance areas are not applied to the visual segment of the approach and missed approach protection is not provided between the MAPt and the heliport or landing location.

5.1.2.3 Direct visual segment description and protection

5.1.2.3.1 *Protection on the direct visual segment.* The direct visual segment is protected for a straight-in landing from the MAPt to the heliport or landing location.

5.1.2.3.2 *Descent point (DP).* A DP is used to identify the end of that portion of the visual segment that should be flown at the minimum descent altitude (MDA) and to identify the point at which the final descent for landing should begin.

5.1.2.3.3 The DP is defined by a distance from the MAPt on the visual segment track. It may be located at the MAPt.

5.1.2.4 Manoeuvring visual segment description and protection

5.1.2.4.1 *Protection on the manoeuvring visual segment.* The manoeuvring visual segment is protected for visual manoeuvres around the heliport or landing location to land from a direction other than directly from the MAPt.

5.1.2.4.2 The OCH for a PinS procedure followed by a manoeuvring visual segment shall not be less than 90 m (295 ft) above the elevation of the HRP.

5.1.2.4.3 The protection of a manoeuvring visual segment is based on the following:

- a) the required turn at the MAPt in order to stay in the “manoeuvre area” cannot be more than 30° (see paragraph 5.1.3.5.6);
- b) a speed of 93 km/h (50 KIAS) or lower in the visual part of flight;
- c) the pilot may descend after the MAPt in the visual segment of the procedure to OCH/2 or 90 m (295 ft) above the heliport/landing location elevation, whichever is greater, taking account of the obstacles identified on the chart;
- d) the pilot shall not descend below OCH/2 or 90 m (295 ft) above the heliport/landing location elevation, whichever is greater, before being aligned on the centre line of the approach surface.

Notes:

1. *The shape of the “manoeuvre area” is based upon the following assumptions:*

- a) *first trajectory: the pilot will fly at the OCA/H directly from the MAPt to the heliport/landing location and then perform a base turn to descend and align on the centre line of the approach surface;*
- b) *second trajectory: the pilot will diverge from the “MAPt-HRP” axis after passing the MAPt in order to manoeuvre to align on the centre line of the approach surface.*

2. *The “manoeuvre area” may be reduced in size if a prominent obstacle is located near the heliport/landing location. In this case, it is expected that the pilot will both avoid overflight of the heliport/landing location and remain within the “manoeuvre area” by turning to intercept the centre line of the approach surface after passing the MAPt and prior to the heliport/landing location. The chart will show:*

- a) *prohibition on overflight of the heliport/landing location;*
- b) *a “no manoeuvring area” at the location of the obstacle;*
- c) *the reduction in the size of the manoeuvre area to prevent flight towards the obstacle.*

5.1.3 PinS approach procedure with a “proceed VFR” instruction

5.1.3.1 A PinS approach with a “proceed VFR” instruction is an instrument approach procedure developed for heliport or landing locations that do not meet the standards for a heliport or where PinS “proceed visually” criteria cannot be met. The PinS instrument approach delivers the helicopter to a MAPt. Prior to or at the MAPt, the pilot determines whether the published minimum visibility or the visibility required by State regulations (whichever is higher), is available to safely transition from IFR to VFR flight and decides to proceed VFR or to execute a missed approach. The pilot shall remain in VFR conditions after departing the MAPt. The pilot is responsible to see and avoid obstacles, and shall cancel IFR at the MAPt (see PANS-ATM, Chapter 4, para 4.8).

5.1.3.2 PinS “proceed VFR” height above surface (HAS) diagram

5.1.3.2.1 *General.* A HAS diagram is charted for a PinS approach procedure with a “proceed VFR” instruction to assist the pilot in the transition from IFR to VFR at the MAPt.

5.1.3.2.2 *HAS diagram description.* The HAS diagram is centred on the MAPt of the PinS approach procedure with a “proceed VFR” instruction. The depiction has a radius of at least 1.5 km (0.8 NM). This minimum value may be increased depending on State specific requirements for Helicopter VFR operations.

5.1.3.2.3 *HAS diagram requirements.* The difference in height between the OCA and the elevation of the highest terrain, water surface or obstacle within a radius of at least 1.5 km (0.8 NM), or other higher value required by the State, of the MAPt is charted. The inbound course to the MAPt is also charted. An example of a HAS diagram is depicted in Figure I-8-5-1. The HAS value in the example is 467 ft and the final approach course to the MAPt is 028°.

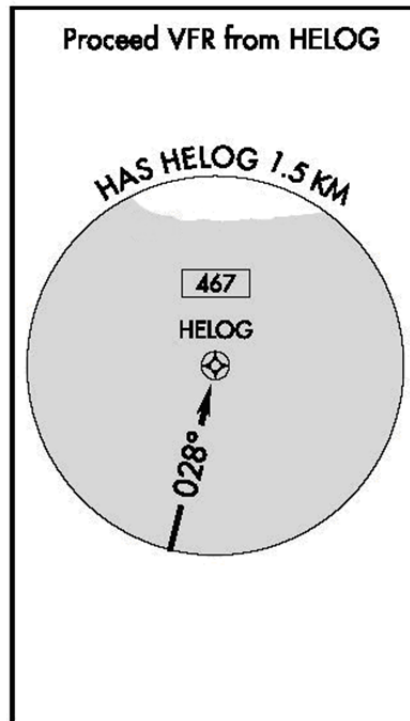

Figure I-8-5-1. HAS diagram (showing as an example both water and land surfaces) for PinS approach procedure with a “proceed VFR” instruction

<p><i>Origin:</i> <i>IFPP / Secretariat</i></p>	<p><i>Rationale</i></p> <p>Current helicopter instrument procedure design criteria do not incorporate the use of vertical guidance that is available today through space-based systems nor does it allow for the design of instrument departures to re-join the IFR en route structure. This amendment addresses both of these deficiencies.</p> <p>This new criteria will allow for more effective arrivals and departures by helicopters to/from heliports and landing locations using the PinS concept and hence improve overall safety and efficiency of helicopter operations</p>
---	--

PROPOSED AMENDMENT TO PANS-OPS, VOLUME II

NOTES ON THE PRESENTATION OF THE AMENDMENT

1. The text of the amendment is arranged to show deleted text with a line through it and new text highlighted with grey shading, as shown below:

~~Text to be deleted is shown with a line through it.~~

text to be deleted

New text to be inserted is highlighted with grey shading.

new text to be inserted

~~Text to be deleted is shown with a line through it~~ followed by the replacement text which is highlighted with grey shading.

new text to replace existing text

**TEXT OF THE PROPOSED AMENDMENT TO
PROCEDURES FOR AIR NAVIGATION SERVICES
AIRCRAFT OPERATIONS
VOLUME II
CONSTRUCTION OF VISUAL AND
INSTRUMENT FLIGHT PROCEDURES**

Editorial note.— Replace the terms “Basic RNP 1” to “RNP 1” and “Basic GNSS” to “GNSS” throughout the document.

PBN — CHARTING

**Part I
GENERAL**

...

**Section 4
ARRIVAL AND APPROACH PROCEDURES**

...

**Chapter 9
CHARTING/AIP**

...

9.5 PROCEDURE NAMING FOR ARRIVAL AND APPROACH CHARTS

...

9.5.2 Procedure identification

9.5.2.1 *General.* The ~~procedure~~ ~~chart~~ identification for procedures requiring ground-based navaids shall only contain the name describing the type of radio navigation aid providing the final approach lateral guidance. Precision approach systems such as ILS or MLS shall be identified by the system name (ILS, MLS, etc.). If two radio navigation aids are used for final approach lateral guidance, the ~~title~~ ~~chart~~ identification shall only include the last radio navigation aid used. For example:

if an NDB is used as the final approach fix and a VOR is used as the last navaid on the final approach to runway 06, the procedure shall be identified as VOR Rwy 06. If a VOR is used for the initial approach followed by a final approach to Rwy 24 using an NDB, the procedure shall be identified as NDB Rwy 24.

Note.— For chart identification of procedures supporting PBN, refer to Part III, Section 5, Chapter 1.

9.5.2.2 If additional navigation aids or equipment are required for the approach procedure, associated additional equipment requirements shall be specified on the plan view of the chart, but not in the ~~title~~ the chart identification.

9.5.2.2.1 The equipment requirements mentioned on the plan view refer only to the equipment on board the aircraft necessary to conduct the procedure in normal mode (i.e. not for backup). For example:

“ADF required” on a VOR approach.

“Dual ADF required”, ~~when required on an NDB approach where two ADFs are required~~ on an NDB approach where two ADF’s are required to fly the final approach segment.

“DME required” on a VOR approach.

~~“SBAS required for this procedure” when the application of SBAS is employed outside the final approach segment.~~

...

9.5.2.3 *Multiple procedures.* A single approach chart may portray more than one approach procedure when the procedures for the intermediate, approach, final approach and missed approach segments are identical, except in the case of RNP procedures supported by different navigation specifications. If more than one approach procedure is depicted on the same chart, the title shall contain the names of all the types of navigation aids used for final approach lateral guidance, separated by the word “or”. There shall be no more than three types of approach procedure on one chart. For example:

...

9.5.3 Duplicate procedure identification

...

9.5.3.3 ~~As some avionics systems are capable of loading only a single approach, States should ensure that the preferred approach is identified using the z suffix.~~ Some avionics systems are not capable of recognizing the duplicate procedure identification as defined in paragraphs 9.5.3.1 and 9.5.3.2. The systems that are not capable will include only one of the duplicate procedures and will not include the duplicate procedure identification letter. States may therefore employ some method of indicating which procedure should be included in those systems, e.g. a note in the AIP, listing of procedures, the consistent use of a defined character for the identification, etc.

9.5.4 Minimum boxes

9.5.4.1 The OCA/H for each aircraft category shall be published in the minimum box on the chart. Where an OCA/H is predicated on a specific navigation aid (e.g. stepdown fixes), or a specific navigation specification (see Part III, Section 5, Chapter 1, 1.4), this shall be clearly identified. For example:

OCA/(OCH)	CAT A	CAT B	CAT C	CAT D	CAT H
LNAV/VNAV	560 (250)	560 (250)	630 (320)	630 (320)	560 (250)
LNAV	710 (400)	710 (400)	810 (500)	810 (500)	710 (400)

or

OCA/(OCH)	CAT A	CAT B	CAT C	CAT D	CAT H
VOR/DME	610 (300)	610 (300)	610 (300)	610 (300)	610 (300)
VOR	660 (350)	660 (350)	660 (350)	660 (350)	660 (350)

or

OCA/(OCH)	CAT A	CAT B	CAT C	CAT D	CAT H
CAT I	210 (170)	210 (170)	220 (180)	230 (190)	210 (170)
RNP 0.3 LOC/DME	290 (250)	290 (250)	290 (250)	290 (250)	290 (250)

9.5.4.2 Approach and landing operations meeting Annex 10 APV I and APV II performance requirements should have charted minima published as “LPV” (localizer performance approach with vertical guidance).

...

Part III RNAV PROCEDURES AND SATELLITE-BASED PROCEDURES PERFORMANCE-BASED NAVIGATION PROCEDURES

Section 1 UNDERLYING PRINCIPLES

Chapter 1 RNAV CONCEPTS

...

1.3 MAGNETIC BEARING ON A PBN (RNAV OR RNP) ROUTE SEGMENT

Magnetic bearing on an PBN route segment. The magnetic bearing for a PBN route segment shall be based on the true course and the magnetic variation at the significant point at origin of the PBN route segment. The magnetic bearing shall be charted to the nearest degree. When a PBN route overlays an existing airway (joint conventional and PBN route) the VOR radial or the NDB magnetic bearing shall be charted.

Editorial note.— Re-number subsequent paragraphs accordingly.

...

Section 5 PUBLICATION

Chapter 1 PUBLICATION AND CHARTING — GENERAL

...

1.2 NOTIFICATION OF DIFFERENCES IN AIP

The obstacle protection afforded to ~~RNAV-PBN~~ procedures is, in most cases, predicated upon a ground track. This track is defined by a number of parameters including, inter alia, waypoint location and type, vertical path angle, maximum speed, minimum altitude, minimum bank angle and the path terminator associated with each procedure leg. If some of these parameters differ from the ICAO Standards, Recommended Practices and Procedures, they should be specified as generic to all ~~RNAV-PBN~~ procedures with a clear statement in the GEN section of the AIP (See Annex 15, Appendix 1, Part 1, GEN 1.7).

1.3 ~~RNAV-DEPARTURES AND ARRIVALS~~

...

1.3.2 Chart identification

1.3.2.1 The chart shall be identified in accordance with Annex 4, 9.5 for departures and 10.5 for arrivals and shall include the term RNAV or RNP, depending on the navigation specification.

...

1.3.3 Route designation

1.3.3.1 Each route shall be assigned a designator that is unique for that aerodrome. The designator shall be defined in accordance with Annex 11, Appendix 3. In addition, the first 4 letters of any 5LNC used in a route designator shall be unique for the aerodrome.

Note 1.— Airborne navigation databases use a maximum of 6 characters to identify a route. If the coded route designator is longer than 6 characters, the fifth character of the 5 LNC is not coded in navigation-databases-database route designation.

Note 2.— The coded route designator and the navigation specification name may be charted alongside the route in the plan view.

...

1.3.4 ~~Chart notes. RNAV related requirements, constraints, or limitations shall be charted as notes, for example:~~

~~navigation sensor limitations: “GNSS required” or “GNSS or DME/DME/IRU required” or “VOR required”;~~

- other equipment requirements: ~~“ATS surveillance service required” or “JAM VOR required” or “JER DME required”;~~
- operational constraints: ~~“Night operations only”;~~
- specific navigation functionality: ~~“RF required” as a general note if RF is a common requirement within a given chart; “BUKIT IL RF required” if in reference to a specific procedure; or “RF required” on the plan view if in reference to a specific segment of the procedure.~~ Additional procedure requirements shall be provided as chart notes. PBN items shall be separated out and published in a PBN requirements box on the plan view of the chart immediately below the chart identifier. The PBN requirements box shall include the identification of the navigation specification used in the procedure design, any navigation sensor limitations and any required functionalities that are described as options in the navigation specification, that is, not included in the core navigation specification as follows:

a) Navigation Specification:

- RNAV 5
- RNAV 1
- RNP 1
- Advanced RNP. (RNP navigation accuracies shall be specified, e.g. RNP 2, RNP 1)
- RNP 0.3

b) Navigation sensor limitations, e.g.:

- GNSS required

c) Functional requirements:

- RF required

Note.— Lengthy text may be shown on the verso of the chart.

...

1.4 RNAV APPROACH

...

1.4.2 Chart identification

1.4.2.1 The chart shall be identified in accordance with Annex 4, 11.6, ~~and shall include the term RNAV.~~

1.4.2.2 ~~RNP~~ Until 30 November 2022, approach charts depicting procedures that meet the RNP APCH navigation specification criteria shall include the term RNAV_(GNSS) in the identification (e.g. RNAV_(GNSS) RWY 23) or, alternatively, as described in 1.4.2.3.

Note.— Charting requirements for RNP procedures that meet the RNP AR APCH navigation specifications are contained in the Required Navigation Performance Authorization Required (RNP AR) Procedure Design Manual (Doc 9905).

Note.— ICAO Circular 336 provides guidance to assist States and other stakeholders with the transition from RNAV to RNP approach chart identification.

1.4.2.3 Other RNAV approach procedures shall include the radio navigation aid or sensor upon which the approach procedure is based, in parentheses in the identification. From 1 December 2022, charts depicting procedures that meet the RNP APCH navigation specification criteria shall include the term RNP in the identification (e.g. RNP RWY 23). The identification shall also include a parenthetical suffix when exceptional conditions occur as described in Table III-5-1-1.

Condition	Suffix	Example
Procedure has only an LPV line of minima	LPV only	RNP RWY 23 (LPV only)
Procedure has only an LNAV/VNAV line of minima	LNAV/VNAV only	RNP RWY 23 (LNAV/VNAV only)
Procedure has both LPV and LNAV/VNAV lines of minima but no LNAV minima	LPV, LNAV/VNAV only	RNP RWY 23 (LPV, LNAV/VNAV only)
Procedure has only an LP line of minima	LP only	RNP RWY 23 (LP only)

Table III-5-1-1. Conditions when suffix shall be applied in chart designation

1.4.2.4 Until 30 November 2022, charts depicting procedures that meet the RNP AR APCH navigation specification shall include the term RNAV_{RNP} in the identification (e.g. RNAV_{RNP} RWY 23) or, alternatively, as described in 1.4.2.5.

Note.— ICAO Circular 336 provides guidance to assist States and other stakeholders with the transition from RNAV to RNP approach chart identification.

1.4.2.5 From 1 December 2022, charts depicting procedures that meet the RNP AR APCH navigation specification shall include the term RNP in the identification with a parenthetical suffix (AR). (e.g. RNP RWY 23 (AR)).

1.4.2.4-6 The chart identification shall include the runway identification for straight-in landing, or a letter designator (a, b, c, etc.) for circling approach (see Part I, Section 4, Chapter 9).

1.4.2.5-7 When more than one RNAV-PBN approach procedure (regardless of navigation specification or sensor type) exists for the same runway, the duplicate identification criteria defined in Part 1, Section 4, Chapter 9 apply. When an RNAV-PBN approach procedure is combined with another PBN approach procedure on the same chart, the multiple procedure criteria defined in Part 1, Section 4, Chapter 9 apply.

Note.— The text in parentheses that is part of the procedure identification does not form part of the ATC clearance.

~~1.4.3~~ ~~Chart notes. RNAV-related requirements concerning equipment, operation or navigation functionality shall be charted as a note.~~

For example:

~~“dual GNSS required” or “IRU required”~~

~~or~~

~~“RF required”.~~

1.4.3 *Chart notes.* When amending or publishing new PBN approach procedures, additional procedure requirements shall be provided as chart notes. PBN items shall be separated out and published in a PBN Requirements Box which includes the identification of the navigation specification used in procedure design and any optional requirements that are not included in the core navigation specification as specified as follows:

a) Navigation specifications:

— RNP APCH

— RNP AR APCH

— Advanced RNP

— RNP 0.3

b) Optional requirements:

— RNP APCH: RF required

— RNP AR APCH: RF required, RNP <0.3, Missed approach RNP < 1

— Advanced RNP: RNP < 1 in initial and intermediate segment

— RNP 0.3: RF required.

1.4.4 Depiction

1.4.4.1 Any RF requirement shall be charted in accordance with paragraphs 1.3.4 and 1.3.5 above.

1.4.4.2 Different ~~required~~ RNP levels ~~navigation accuracy requirements~~ on different initial segment legs ~~must~~ shall be charted with a note. The required note may be charted with the applicable leg, or as a procedure note with reference to the applicable leg. If the same RNP ~~value~~ navigation accuracy applies to all initial and intermediate segments, then a general procedure note should be used as indicated in 1.4.3.

1.4.5 Minima

Minima for ~~RNAV~~ approach procedures shall be labelled on the chart as follows:

- ~~— a) non precision approach procedures: “LNAV”; and~~
- ~~— b) approach procedures with vertical guidance (APV):~~
 - ~~—— 1) SBAS LNAV/VNAV performance level and Baro VNAV: “LNAV/VNAV”; and~~
 - ~~—— 2) SBAS APV I/II performance level: “LPV”.~~

Minima label	Associated navigation specification
LNAV	RNP APCH
LNAV/VNAV	RNP APCH
LP	RNP APCH
LPV	RNP APCH
RNP 0.x	RNP AR APCH

...

<p><i>Origin:</i> IFPP / Secretariat</p>	<p><i>Rationale</i></p> <p>Inconsistencies with the charts, the PBN approvals and avionics displays have created confusion. The rationalization of procedure identification detailed in this amendment addresses the issue and provides a simpler and clearer method for procedure naming and a standardized approach to charting.</p> <p>Another element of this proposal concerns that there is no standard concerning the depiction of magnetic bearings on RNAV routes. This may result in a disparity between what is provided on the chart and what is displayed to pilots. This amendment will harmonize the charted and displayed magnetic directional values which can be expected upon rollout after passing a significant point on an RNAV route. This will improve situational awareness and provide a means to cross-check the airborne data.</p>
--	--

PBN — SUPPORT FOR NEW NAVSPECS

Part III**Section 1
UNDERLYING PRINCIPLES****Chapter 1
RNAV CONCEPTS****1.1 GENERAL**

...

1.1.4 The ICAO *Performance-based Navigation (PBN) Manual* (Doc 9613) provides a detailed explanation of the PBN concept and guidance on how to implement PBN applications as well as navigation specifications for the following applications (See also Table III-1-1-1):

...

- e) *RNP 2*: used to support RNP operations in the en-route phase of flight in oceanic, remote area and continental airspace. Obstacle clearance criteria are detailed in Part III, Section 1, Chapter 2 and Section 3 Chapter 8.
- ~~e-f)~~ *Basic-RNP 1*: used to support RNAV-RNP operations on SIDs, on STARs and on approaches up to the FAF/FAP with no, or limited, ATS surveillance and with low to medium density traffic. Obstacle clearance criteria are detailed in Part III, Section 1, Chapter 2, and Section 3, Chapters 1, 2, 7 and 8.
- g) *Advanced RNP (ARNP)*: used to support RNP operations in en-route continental airspace and on SIDs, STARs and approach procedures. ARNP requirements include RNP 0.3 in final approach; RNP 1 or 2 in en-route continental; RNP 1 in SIDs, STARs, initial/intermediate approaches and missed approaches. Optional requirements include applications for oceanic/remote airspace and a scalability option which allows any RNP value between 1.0 and 0.3, in 0.1NM increments, in all terminal flight phases outside final approach. Obstacle clearance criteria are detailed in Part III, Section 1, Chapter 2 and Section 3 Chapters 1, 2, 3, 4, 7 and 8.
- h) *RNP 0.3*: used to support helicopter RNP operations in all phases of flight except final approach. Obstacle clearance criteria are detailed in Part III, Section 1, Chapter 2 and Part IV.
- ~~f-i)~~ *RNP APCH*: used to support RNAV-RNP approach operations up to RNP 0.3, designed with straight segments. May include a requirement for Baro-VNAV capabilities to LNAV, LNAV/VNAV, LP and LPV minima. Obstacle clearance criteria are detailed in Part III, Section 1, Chapter 2, and Section 3, Chapters 2, 3, 4, 5 and 7.
- ~~g-j)~~ *RNP AR APCH*: used to support RNAV-RNP approach operations with a final approach segment of RNP 0.3 or lower, designed with straight segments and/or fixed radius segments.

Note 1.— The criteria to develop RNP AR approach procedures are detailed in the Required Navigation Performance Authorization Required (RNP AR) Procedure Design Manual (Doc 9905).

Note 2.— The navigation specifications, together with associated appendices and attachments, in the ICAO Performance-based Navigation (PBN) Manual (Doc 9613) also contain details of specific navigation functions that may be optional or mandatory, depending upon the navigation specification.

- a) All navigation specifications intended for terminal and approach procedures require the ability to execute leg transitions and maintain tracks consistent with specific ARINC 424 path terminators. In particular, the ability to fly constant radius turns in terminal airspace, using the RF path terminator, is addressed in the RNP AR APCH navigation specification and in Doc. 9613, Volume II, Part C, Appendix 1. The RF path terminator functionality is required in the ARNP navigation specification and is an optional function in the RNP 1, RNP 0.3 and RNP APCH navigation specifications. Its application in RNP AR APCH operations is addressed in Doc 9905.*
- b) The ability to fly constant radius turns in the en-route phase of flight is addressed in Doc 9613, Volume II, Part C, Appendix 2. Fixed radius transitions (FRT) are associated with individual waypoints on an en-route structure and may be used in ARNP and RNP 2 applications. Note: Guidance on how to employ FRT is still being developed and once it is mature, design criteria for FRT will be included in PANS-OPS.*
- c) The use of barometric altitude and RNAV information in the definition of vertical flight paths and vertical guidance in relation to a path, known as Baro-VNAV, is addressed in Doc 9613, Volume II, Attachment A.*

Table III-1-1-1. Navigation specification per flight phase

	Flight Phase							
	Oceanic/Remote	En-route	Arrival	Approach				Departure
				Initial	Intermediate	Final	Missed ¹	
RNAV 10	10							
RNAV 5		5	5 ²					
RNP 4	4							
RNP 2	2	2						
RNAV 2		2	2					2
Advanced RNP ³	2	2 or 1	1 - 0.3	1 - 0.3	1 - 0.3	0.3	1 - 0.3	1 - 0.3
RNP 1			1	1	1		1	1
RNAV 1		1	1	1	1		1	1
RNP 0.3 (Cat H)		0.3	0.3	0.3	0.3		0.3	0.3
RNP APCH (Part A)				1	1	0.3	1	
RNP APCH (Part B)				1	1	Angular	1 or 0.3 (initial straight MISAP)	
RNP AR APCH				1-0.1	1-0.1	0.3-0.1	1-0.1	

Notes:

1. RNP requirements do not apply to initial and intermediate missed approach segments.
2. RNAV 5 may be used for initial parts of STARs outside 30NM from the ARP.
3. Advanced RNP core requirements are limited to RNP 1 in all flight phases except final approach (RNP 0.3) and RNP 2 in oceanic/remote and en-route continental. A scalability option will allow accuracy values between 0.3 and 1.0, in 0.1NM increments, in all flight phases except oceanic/remote/en-route continental (RNP 1 and RNP 2) and final approach (RNP 0.3).

1.2 FLIGHT TECHNICAL ERROR

The 95 per cent FTE values from which the design criteria for PBN applications have been derived are detailed in ~~Table III-1-1-1~~, based upon the following formulae:

For RNAV, FTE = $\frac{1}{2}$ required navigation accuracy

For RNP ≥ 0.5 , FTE = $\frac{1}{2}$ RNP

For RNP ≤ 0.5 , FTE = 463 m (0.25 NM)

~~Table III-1-1-1~~ Table III-1-1-2.

...

Note.— The FTE values value for RNAV 5 and RNP 4 are those is that specified in the navigation specifications in the Performance-based Navigation Manual (Doc 9613) and may be considered to be conservative in the context of the demonstrable performance.

1.3 BUFFER VALUES

1.3.1 The RNAV and RNP cross-track tolerance values are ~~comprised of~~ derived from the NSE and FTE. ~~These balances~~ They are both treated as though they are Gaussian and are determined by the RSS of these two errors. (For GNSS-based RNP systems, the NSE is small and the FTE is the dominant component.) However, it is known that the distributions which include, inter alia, blunder errors, are not truly Gaussian and the tails of the distributions cannot be accurately determined without an extensive data set, which is not available. These tails are therefore accounted for in the procedure design criteria for ~~RNP 4, Basic RNP 1, RNP APCH, RNAV 1, RNAV 2 and RNAV 5~~ all PBN applications except RNP AR by an additional “buffer value”, based upon the aircraft characteristics (speed, manoeuvrability, etc.) and the phase of flight (pilot reaction time, time of exposure, etc.), to address excursions beyond a 3 standard deviation (3σ) value.

1.3.2 The following buffer values (BV) are applied in ~~RNP 4, Basic RNP 1, RNP APCH, RNAV 1, RNAV 2 and RNAV 5~~ all PBN applications except RNP AR:

...

1.4 OBSTACLE CLEARANCE AREA

...

1.4.3 Merging Segments of different widths

Larger area semi width values are merged, at 30° to the nominal track, to achieve smaller area semi width values at one ATT after the designated waypoint. Smaller semi area width values are splayed, at 15° to the nominal track, to larger area semi width values from one ATT prior to the designated waypoint. This is illustrated in Figure III-1-1-1. The merging and splaying at flight phase interfaces is addressed in paragraph 1.4.4.

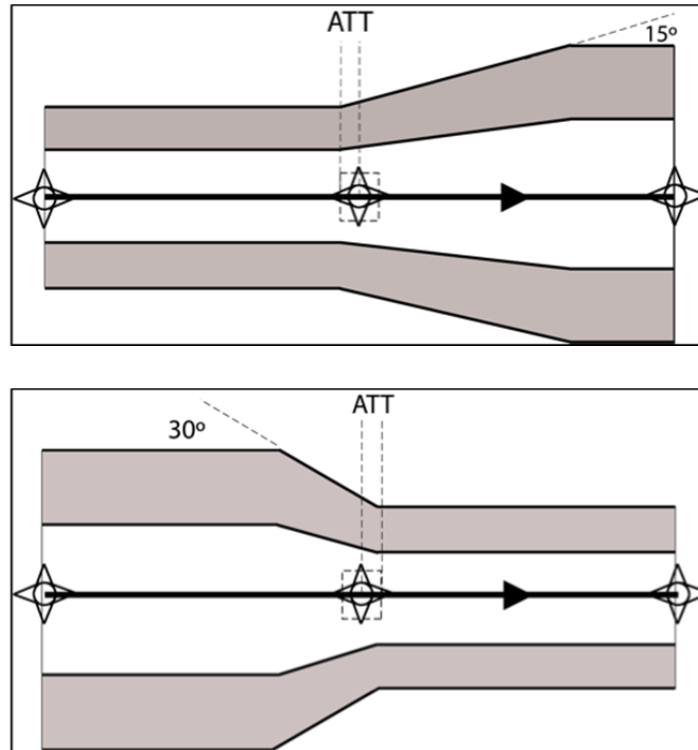

Figure III-1-1-1. Merging segments of different widths

Editorial note.— Re-number subsequent paragraphs and figures accordingly.

...

Chapter 2 BASIC GNSS RNAV

2.1 GENERAL

2.1.1 This chapter provides the cross-track and along-track parameters for basic GNSS used as input to the procedure construction criteria provided in Section 3 of this part. Basic GNSS positioning is applicable to the following navigation specifications:

- a) RNAV 5;
- b) RNAV 2;
- c) RNAV 1;
- d) RNP 4;
- e) RNP 2;
- e)-f) ~~Basic RNP-1; and~~
- g) Advanced RNP;
- h) RNP 0.3 (Cat H only); and
- Ⓣ)-i) RNP APCH (except for LP/LPV minima).

2.2 XTT, ATT AND AREA SEMI-WIDTH

2.2.1 *XTT and ATT for RNP navigation specifications.* The total system error (TSE) is dependent upon position estimation error (SIS error and airborne receiver error), path definition error, display error and flight technical error. The RNP navigation specifications define lateral TSE values as follows:

- a) *RNP 4.* The lateral TSE and the along-track error will not exceed ± 7.4 km (4 NM) for at least 95 per cent of the total flight time.
- b) *RNP 2.* The lateral TSE and the along-track error will not exceed ± 3.8 km (2 NM) for at least 95 per cent of the total flight time.
- ~~b-c)~~ *Basic-RNP-1.* The lateral TSE and the along-track error will not exceed ± 1.9 km (1 NM) for at least 95 per cent of the total flight time.
- d) *Advanced RNP.* The lateral TSE and the along-track error will not exceed the applicable accuracy for the phase of flight:
 - oceanic/remote: ± 3.8 km (2 NM)
 - continental en-route: ± 3.8 km (2 NM) or ± 1.9 km (1 NM)
 - departure, arrival, initial-, intermediate-, missed approach: $\pm (0.56$ km (0.3 NM) to 1.9 km (1 NM)) with 186 m (0.1 NM) increment
 - final approach: ± 0.56 km (0.3 NM)
 for at least 95 per cent of the total flight time.
- e) *RNP 0.3 (Cat H only).* The lateral TSE and the along-track error will not exceed ± 0.56 km (0.3 NM) for at least 95 per cent of the total flight time.
- ~~e-f)~~ *RNP APCH (LNAV and LNAV/VNAV only).* The lateral TSE and the along-track error will not exceed ± 1.9 km (1 NM) 95 per cent of the total flight time during the initial and intermediate segments of the approach and during the missed approach, where the missed approach is predicated upon an RNAV requirement. The lateral TSE and the along-track error will not exceed ± 0.56 km (0.3 NM) 95 per cent of the total flight time during the final approach.

Note.— The final approach and missed approach segment of RNP APCH down to LP or LPV minima is addressed in Part III, Section 3, Chapter 5.

The TSE is used to define the XTT and ATT values as follows:

$$\text{XTT} = \text{TSE}$$

$$\text{ATT} = 0.8 * \text{TSE}$$

...

2.2.3 Area semi-width

...

2.2.3.3 Results of calculations of the semi-width are shown as follows:

- a) RNP 4: Tables III-1-2-1 and III-1-2-2;
- b) RNP 2: Tables III-1-2-3 and III-1-2-4;
- b)-c) Basic-RNP-1 (aeroplane/Aeroplane): Tables III-1-2-3-III-1-2-5 and III-1-2-4-III-1-2-6;
- e)-d) Basic-RNP-1 (CAT H): Tables III-1-2-5-III-1-2-7 and III-1-2-6-III-1-2-8;
- e) Advanced RNP: Tables III-1-2-9 and III-1-2-10 Optional ARNP semi-width and ATT values can be calculated using the formulae in paragraph 2.2.1 and 2.2.3.
- f) RNP 0.3 (CAT H): Tables III-1-2-11 and III-1-2-12;
- d)-g) RNP (APCH) (aeroplane/Aeroplane): Tables III-1-2-7-III-1-2-13 and III-1-2-8-III-1-2-14;
- e)-h) RNP APCH (CAT H): Tables III-1-2-9-III-1-2-15 and III-1-2-10-III-1-2-16;
- f)-i) RNAV 1 and RNAV 2: Tables III-1-2-11-III-1-2-17 and III-1-2-12-III-1-2-18;
- g)-j) RNAV 1 and RNAV 2(CAT H): Tables III-1-2-13-III-1-2-19 and III-1-2-14-III-1-2-20;
- h)-k) RNAV 5: Tables III-1-2-15-III-1-2-21 and III-1-2-16-III-1-2-22.

Table III-1-2-1. XTT, ATT and area semi-width for RNP 4 in the en-route phase of flight (km-m)

<i>En-route/STAR/SID (>56 km ARP)</i>		
<i>XTT</i>	<i>ATT</i>	<i>½ A/W</i>
7.41-7408	5.93-5926	14.82-1482

Table III-1-2-2. XTT, ATT and area semi-width for RNP 4 in the en-route phase of flight (NM)

<i>En-route/STAR/SID (>30 NM ARP)</i>		
<i>XTT</i>	<i>ATT</i>	<i>½ A/W</i>
4.00	3.20	8.00

Table III-1-2-3. XTT, ATT, area semi-width for RNP 2 in en-route phase of flight (m)

<i>En-route / STAR / SID (>56 km ARP)</i>		
<i>XTT</i>	<i>ATT</i>	<i>½ A/W</i>
3704	2963	9260

Table III-1-2-4. XTT, ATT, area semi-width for RNP 2 in en-route phase of flight (NM)

<i>En-route / STAR / SID (>30 NM ARP)</i>		
<i>XTT</i>	<i>ATT</i>	<i>½ A/W</i>
2.00	1.60	5.00

Table III-1-2-3-5. XTT, ATT and area semi-width for Basic RNP-1 (aeroplane-CAT H) in arrival and departure phases of flight (km)

<i>STAR / SID (>56 km ARP)</i>			<i>STAR / SID(<56 km ARP)</i>			<i>SID (<28 km ARP)</i>		
<i>XTT</i>	<i>ATT</i>	<i>½ A/W</i>	<i>XTT</i>	<i>ATT</i>	<i>½ A/W</i>	<i>XTT</i>	<i>ATT</i>	<i>½ A/W</i>
1.85	1.48	6.48	1.85	1.48	4.63	1.85	1.48	3.70
1852	1482	6482	1852	1482	4630	1852	1482	3704

Table III-1-2-4-6. XTT, ATT and area semi-width for Basic-RNP 1 (aeroplane) in arrival and departure phases of flight (NM)

<i>STAR / SID (>30 NM ARP)</i>			<i>STAR / SID(<30 NM ARP)</i>			<i>SID (<15 NM ARP)</i>		
<i>XTT</i>	<i>ATT</i>	<i>½ A/W</i>	<i>XTT</i>	<i>ATT</i>	<i>½ A/W</i>	<i>XTT</i>	<i>ATT</i>	<i>½ A/W</i>
1.00	0.80	3.50	1.00	0.80	2.50	1.00	0.80	2.00

Table III-1-2-5-7. XTT, ATT and area semi-width for Basic-RNP 1 (CAT H) in arrival and departure phases of flight (km-m)

STAR / SID (>56 km ARP)			STAR / SID(<56 km ARP)			SID (<28 km ARP)		
XTT	ATT	½ A/W	XTT	ATT	½ A/W	XTT	ATT	½ A/W
1.85 1852	1.48 1482	4.63 4630	1.85 1852	1.48 1482	4.07 4074	1.85 1852	1.48 1482	3.43 3426

Table III-1-2-6-8. XTT, ATT and area semi-width for Basic-RNP 1 (CAT H) in arrival and departure phases of flight (NM)

STAR / SID (>30 NM ARP)			STAR / SID(<30 NM ARP)			SID (<15 NM ARP)		
XTT	ATT	½ A/W	XTT	ATT	½ A/W	XTT	ATT	½ A/W
1.00	0.80	2.50	1.00	0.80	2.20	1.00	0.80	1.85

Table III-1-2-9. XTT, ATT and area semi-width for Advanced-RNP in all phases of flight (Aeroplane) (m)

RNP	En-route (Continental & Remote)			STAR / SID (>56 km ARP)			STAR / SID / IF / IAF / Missed Approach (<56 km ARP)			FAF			MAPt			Missed Approach / SID (<28 km ARP)		
	XTT	ATT	½ A/W	XTT	ATT	½ A/W	XTT	ATT	½ A/W	XTT	ATT	½ A/W	XTT	ATT	½ AW	XTT	ATT	½ A/W
2	3704	2964	9260	■	■	■	■	■	■	■	■	■	■	■	■	■	■	■
1	1852	1482	6482	1852	1482	6482	1852	1482	4630	■	■	■	■	■	■	1852	1482	3704
0.3	■	■	■	■	■	■	■	■	■	556	444	2685	556	444	1759	■	■	■

Table III-1-2-10. XTT, ATT and area semi-width for Advanced-RNP in all phases of flight (Aeroplane) (NM)

RNP	En-route (Continental & Remote)			STAR / SID (>30NM ARP)			STAR / SID (<30NM ARP)/ IAF / IF / Missed Approach			FAF			MAPt			Missed Approach / SID (<15 NM ARP)		
	XTT	ATT	½ A/W	XTT	ATT	½ A/W	XTT	ATT	½ A/W	XTT	ATT	½ A/W	XTT	ATT	½ A/W	XTT	ATT	½ A/W
2	2	1.6	5.0	-	-	-	-	-	-	-	-	-	-	-	-	-	-	-
1	1	0.8	3.5	1	0.8	3.5	1	0.8	2.5	-	-	-	-	-	-	1	0.8	2
0.3	-	-	-	-	-	-	-	-	-	0.3	0.24	1.45	0.3	0.24	0.95	-	-	-

Table III-1-2-11. XTT, ATT and area semi-width for RNP 0.3 (CAT H) in all phases of flight (m)

En-route / STAR / SID (>56 km ARP)			STAR / SID / IF / IAF / Missed Approach (≤56 km ARP)			SID / Missed Approach (<28 km ARP)		
XTT	ATT	½ A/W	XTT	ATT	½ A/W	XTT	ATT	½ A/W
556	444	2685	556	444	2130	556	444	1482

Table III-1-2-12. XTT, ATT and area semi-width for RNP 0.3 (CAT H) in all phases of flight (NM)

En-route / STAR / SID (>30 NM ARP)			STAR / SID / IF / IAF / Missed Approach (≤30 NM ARP)			SID / Missed Approach (<15 NM ARP)		
XTT	ATT	½ A/W	XTT	ATT	½ A/W	XTT	ATT	½ A/W
0.30	0.24	1.45	0.30	0.24	1.15	0.30	0.24	0.80

Table III-1-2-7-13. XTT, ATT and area semi-width for RNP APCH (CAT A to E aeroplane) in initial/intermediate/final approach and missed approach phases of flight (km-m)

<i>IF / IAF / Missed Approach (<56 km ARP)</i>			<i>FAF</i>			<i>MAPt / Initial Straight Missed Approach (LP/LPV only)</i>			<i>Missed Approach (<28 km ARP)</i>		
<i>XTT</i>	<i>ATT</i>	<i>½ A/W</i>	<i>XTT</i>	<i>ATT</i>	<i>½ A/W</i>	<i>XTT</i>	<i>ATT</i>	<i>½ A/W</i>	<i>XTT</i>	<i>ATT</i>	<i>½ A/W</i>
1.85 1852	1.48 1482	4.63 4630	0.56 556	0.44 444	2.69 2685	0.56 556	0.44 444	1.76 1759	1.85 1852	1.48 1482	3.70 3704

Table III-1-2-8-14. XTT and ATT, area semi-width for RNP APCH (CAT A to E aeroplane) in initial/intermediate/final approach and missed approach phases of flight (NM)

<i>IF / IAF / Missed Approach (<30 NM ARP)</i>			<i>FAF</i>			<i>MAPt / Initial Straight Missed Approach (LP/LPV only)</i>			<i>Missed Approach (<15 NM ARP)</i>		
<i>XTT</i>	<i>ATT</i>	<i>½ A/W</i>	<i>XTT</i>	<i>ATT</i>	<i>½ A/W</i>	<i>XTT</i>	<i>ATT</i>	<i>½ A/W</i>	<i>XTT</i>	<i>ATT</i>	<i>½ A/W</i>
1.00	0.80	2.50	0.30	0.24	1.45	0.30	0.24	0.95	1.00	0.80	2.00

Table III-1-2-9-15. XTT, ATT and area semi-width for RNP APCH (CAT H) in initial/intermediate/final approach and missed approach phases of flight (km-m)

<i>IF / IAF / Missed Approach (<56 km ARP)</i>			<i>FAF</i>			<i>MAPt / Initial Straight Missed Approach (LP/LPV only)</i>			<i>Missed Approach (<28 km ARP)</i>		
<i>XTT</i>	<i>ATT</i>	<i>½ A/W</i>	<i>XTT</i>	<i>ATT</i>	<i>½ A/W</i>	<i>XTT</i>	<i>ATT</i>	<i>½ A/W</i>	<i>XTT</i>	<i>ATT</i>	<i>½ A/W</i>
1.85 1852	1.48 1482	4.07 4074	0.56 556	0.44 444	2.13 2130	0.56 556	0.44 444	1.48 1482	1.85 1852	1.48 1482	3.43 3426

Table III-1-2-10-16. XTT, ATT and area semi-width for RNP APCH (CAT H) in en-route, arrival, initial/intermediate/final approach and missed approach phases of flight (NM)

<i>IF / IAF / Missed Approach (<30 NM ARP)</i>			<i>FAF</i>			<i>MAPt / Initial Straight Missed Approach (LP/LPV only)</i>			<i>Missed Approach (<15 NM ARP)</i>		
<i>XTT</i>	<i>ATT</i>	<i>½ A/W</i>	<i>XTT</i>	<i>ATT</i>	<i>½ A/W</i>	<i>XTT</i>	<i>ATT</i>	<i>½ A/W</i>	<i>XTT</i>	<i>ATT</i>	<i>½ A/W</i>
1.00	0.80	2.20	0.30	0.24	1.15	0.30	0.24	0.80	1.00	0.80	1.85

Table III-1-2-11-17. XTT, ATT and area semi-width for RNAV 1 and RNAV 2 (CAT A to E) in en-route, arrival, initial/intermediate approach and departure phases of flight (km-m)

<i>En-route / STAR / SID</i> (>56 km ARP)			<i>STAR / IF / IAF / SID</i> (<56 km ARP)			<i>SID (<28 km ARP)</i>		
<i>XTT</i>	<i>ATT</i>	$\frac{1}{2}$ <i>A/W</i>	<i>XTT</i>	<i>ATT</i>	$\frac{1}{2}$ <i>A/W</i>	<i>XTT</i>	<i>ATT</i>	$\frac{1}{2}$ <i>A/W</i>
3.70	2.96	9.26	1.85	1.48	4.63	1.85	1.48	3.70
3704	2963	9260	1852	1482	4630	1852	1482	3704

Table III-1-2-12-18. XTT, ATT and area semi-width for RNAV 1 and RNAV 2 (CAT A to E) in en-route, arrival, initial/intermediate approach and departure phases of flight (NM)

<i>En-route / STAR / SID</i> (>30 NM ARP)			<i>STAR / IF / IAF / SID</i> (<30 NM ARP)			<i>SID (<15 NM ARP)</i>		
<i>XTT</i>	<i>ATT</i>	$\frac{1}{2}$ <i>A/W</i>	<i>XTT</i>	<i>ATT</i>	$\frac{1}{2}$ <i>A/W</i>	<i>XTT</i>	<i>ATT</i>	$\frac{1}{2}$ <i>A/W</i>
2.00	1.60	5.00	1.00	0.80	2.50	1.00	0.80	2.00

Table III-1-2-13-19. XTT, ATT and area semi-width for RNAV 1 and RNAV 2 (CAT H) in en-route, arrival, initial/intermediate approach and departure phases of flight (km)

<i>En-route/STAR/SID</i> (>56 km ARP)			<i>STAR/IF/IAF/SID</i> (<56 km ARP)			<i>SID</i> (<28 km ARP)		
<i>XTT</i>	<i>ATT</i>	$\frac{1}{2}$ <i>A/W</i>	<i>XTT</i>	<i>ATT</i>	$\frac{1}{2}$ <i>A/W</i>	<i>XTT</i>	<i>ATT</i>	$\frac{1}{2}$ <i>A/W</i>
3.70	2.96	7.40	1.85	1.48	4.07	1.85	1.48	3.42

Table III-1-2-14-20. XTT, ATT and area semi-width for RNAV 1 and RNAV 2 (CAT H) in en-route, arrival, initial/intermediate approach and departure phases of flight (NM)

<i>En-route/STAR/SID</i> (>30 NM ARP)			<i>STAR/IF/IAF/SID</i> (<30 NM ARP)			<i>SID</i> (<15 NM ARP)		
<i>XTT</i>	<i>ATT</i>	$\frac{1}{2}$ <i>A/W</i>	<i>XTT</i>	<i>ATT</i>	$\frac{1}{2}$ <i>A/W</i>	<i>XTT</i>	<i>ATT</i>	$\frac{1}{2}$ <i>A/W</i>
2.00	1.60	4.00	1.00	0.80	2.20	1.00	0.80	1.85

Table III-1-2-15-21. XTT, ATT and area semi-width for RNAV 5 in the en-route phase of flight (km-m)

<i>En-route/STAR/SID (>56 km ARP)</i>		
<i>XTT</i>	<i>ATT</i>	<i>½ A/W</i>
4.65	3.72	10.69
4650	3720	10690

Table III-1-2-16-22. XTT, ATT and area semi-width for RNAV 5 in the en-route phase of flight (NM)

<i>En-route/STAR/SID (>30 NM ARP)</i>		
<i>XTT</i>	<i>ATT</i>	<i>½ A/W</i>
2.51	2.01	5.77

...

Editorial note.— Delete Chapter 5 in toto.

**Chapter 5
GENERAL CRITERIA FOR SBAS GNSS RECEIVERS**

...

Editorial note.— Delete Chapter 7 in toto.

**Chapter 7
RNP**

...

**Section 2
GENERAL CRITERIA**

**Chapter 1
MINIMUM LENGTH OF A SEGMENT
LIMITED BY TWO WAYPOINTS**

...

Table III-2-1-21. Minimum length of an RNAV segment limited by at least one waypoint which is not a turning waypoint

<i>Phase of flight</i>	<i>D: minimum distance to waypoint*</i>
En-route More than 56 km (30 NM) from departure or	9.3 km (5.0 NM)

destination ARP

STARs, Initial within 56 km (30 NM) of the ARP 5.6 km (3.0 NM)

SID within 28 km (15 NM) from DER, intermediate and final approach 2.8 km (1.5 NM)

Missed approaches and SIDs within 56 km (30 NM) of the ARP 5.6 km (3.0 NM)

* When the stabilization distance is greater than D, D is equal to the stabilization distance.

...

Chapter 2 TURN PROTECTION AND OBSTACLE ASSESSMENT

...

2.4 RF TURN METHOD

2.4.1 General

2.4.1.1 A radius to fix (RF) turn is a constant radius circular path (see Figure III-2-2-13) defined by the:

- a) tangential point at the end of the turn;
- b) centre of the turn;
- c) turn radius;
- d) ~~XTT value; and~~
- e) ~~buffer value (BV), where the BV is defined in Table III-1-1-2 for RNAV applications and Table III-1-7-1 for RNP applications.~~

2.4.1.2 The value of the turn radius for arrival, approach and departure phases of flight is determined as follows:

$$r = (V+V_w)^2/127094 \cdot \tan \theta \quad r \text{ in km; } V \text{ and } V_w \text{ in km/h}$$

$$r = (V+V_w)^2/68626 \cdot \tan \theta \quad r \text{ in NM; } V \text{ and } V_w \text{ in kt}$$

Where

V is the aircraft maximum true airspeed in the turn

V_w is the maximum wind speed at the highest point in the turn

θ is the maximum bank angle for the phase of flight (assumed to be equal to the average achieved bank angle, as described in the various chapters for the different phases of flight, plus 5°) necessary to define the desired track.

2.4.1.3 *Maximum TAS.* The maximum TAS should be based upon the IAS for the maximum height during the turn, corrected for the maximum deviation from the ISA value for the aerodrome.

2.4.1.4 *Maximum wind speed.* Maximum wind speed is defined as the ICAO standard wind or, where statistical wind data are available, the maximum wind speed within 95 per cent probability on an omni-directional basis. If no statistical wind data are available, the following values may be applied on SIDs and Missed Approaches:

- 30 kts below 2000 ft above AD elevation
- 40 kts between 2000 ft and 3000ft above AD elevation

2.4.1.5 To calculate the altitude at the end of a RF leg, for TAS and wind, the distance flown is the arc length between the two waypoints defined by the nominal radius.

2.4.1.6 Speed limitations during the turn, if applicable, shall be applied at the end of the RF leg for SIDs/Missed Approaches and at the beginning for STARs and approaches.

2.4.1.7 *Bank angle.* Bank angles up to 25° may be used for any turn above 400ft above A/D elevation. Turns shall not be initiated below 400 ft above AD elevation.

2.4.1.8 To calculate the height of the OIS for obstacles on an RF leg in a departure or missed approach, the distance is based on an arc length with a radius of $(r-186\text{m}) [(r-0.1\text{NM})]$.

2.4.1.9 The area semi-width is based upon the XTT and the BV, as detailed in Part III, Section 1, Chapters 1 and 2 and further modified as detailed in the paragraphs below.

2.4.1.10 The turn radius shall not be smaller than:

- a) 2 x RNP value of the inbound and outbound segments.
- b) $\frac{1}{2}$ AW of the inbound and outbound segments.

2.4.2 Protection of the outer turn boundary

2.4.2.1 *Primary area.* The outer edge of the primary area is defined by the segment of a circle:

- a) centred on point O (centre of the turn);
- b) having a radius $r + [0.75 \cdot \text{XTT} + \text{BV}/2] / \cos 45^\circ$ or $r + 0.75 \cdot \text{XTT} + \text{BV}/2 + 93 \text{ m}$ (0.05 NM); and
- c) delimited by the edges of the adjacent straight segments (points J and M in Figure III-2-2-13 points A and C in Figure III-2-2-13).

2.4.2.2 *Secondary area.* The outer edge of the secondary area is defined by a segment of a circle offset at a distance of $0.75 \cdot \text{XTT} + \text{BV}/2$ from, and parallel to, the outer edge of the primary area:

- a) centred on point O;
- b) having a radius of $r + 1.5 \cdot \text{XTT} + \text{BV} + 186\text{m}$ (0.1NM);
- c) delimited by the edges of the adjacent straight segments (points B and D in Figure III-2-2-13).

2.4.3 Protection of the inner turn boundary

2.4.3.1 *Primary area.* The inner edge of the primary area of a turn is defined by the segment of a circle:

- centred on point I at a distance of $[0.75 \cdot XTT + BV/2] / \cos 45^\circ$ from the centre of the turn (point O) centred on point O;
- having a radius $r - [0.75 \cdot XTT + BV/2]$; and
- delimited by the edges of the adjacent straight segments (points P and R in Figure III-2-2-13).

2.4.3.2 *Secondary area.* The inner-outer edge of the secondary area is defined by a segment of a circle offset at a distance of $0.75 \cdot XTT + BV/2$ from, and parallel to, the inner edge of the primary area:

- centred on point O;
- having a radius $r - [1.5 \cdot XTT + BV]$;
- delimited by the edges of the adjacent straight segments.

2.4.4 Splays in RF turns

2.4.4.1 In a departure or a missed approach where the splay has not been completed before the start of an RF turn, a spiral arc shall be continued on the outside of the turn from the latest ATT at the edge of the splay in accordance with the following formula:

$$r_t = \min[r_o, (r_s + (2\pi r_s \frac{\alpha}{360}) \tan 15^\circ)]$$

Where

r_t is the spiral radius of the arc

r_o is the radius of the secondary area boundary ($1.5 \cdot XTT + BV + 0.1$)

r_s is the distance from the turn centre to the edge of the linear splay at the start of the RF

α is the number of degrees track angle change completed.

2.4.4.2 The outer spiral arc shall start at a distance from the waypoint at the start of the RF turn, corresponding to the latest ATT plus 3 seconds of flight (pilot reaction time at the nominal TAS plus tailwind. It shall terminate when the required $\frac{1}{2}$ A/W is reached or abeam the succeeding waypoint, when the 15° splay will continue on the subsequent leg.

2.4.4.3 A tailwind of 10 kts should be used for the first 500 ft above AD elevation, then 20 kts from 500 ft to 1000 ft above AD elevation and 30 kts from 1000 ft to 2000 ft above AD elevation.

2.4.4.4 The inside of the turn shall also continue to splay in accordance with the following formula:

$$r_t = \max[r_o, (r_s - (2\pi r_s \frac{\alpha}{360}) \tan 15^\circ)]$$

The inner spiral arc shall start prior to the waypoint at the start of the RF turn, at a distance corresponding to the earliest ATT. It shall terminate abeam the succeeding waypoint, when the 15° splay will continue on the subsequent leg. This is illustrated in Figure III-2-2-14.

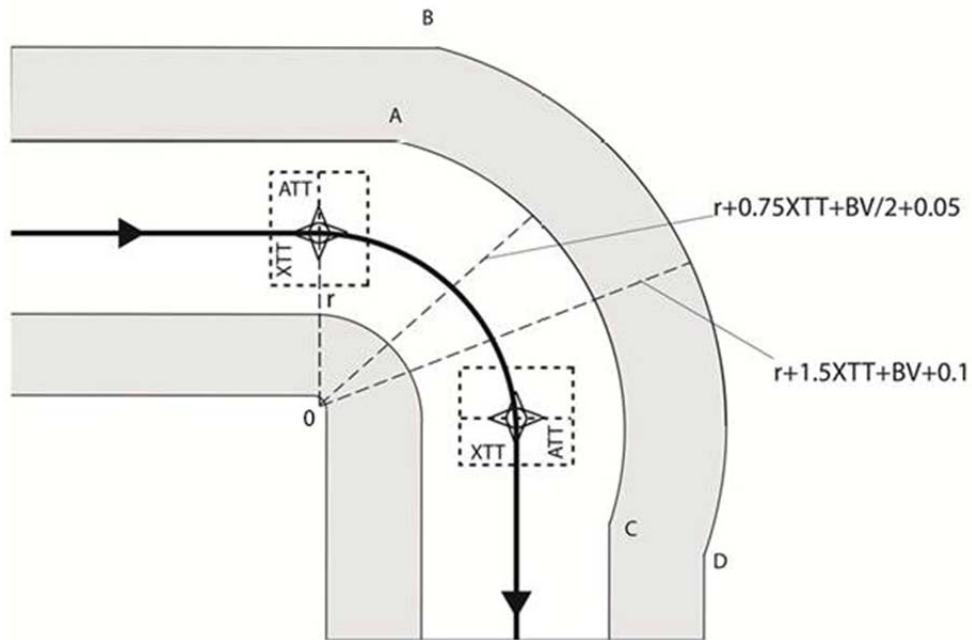

Figure III-2-2-13. RF turn protection

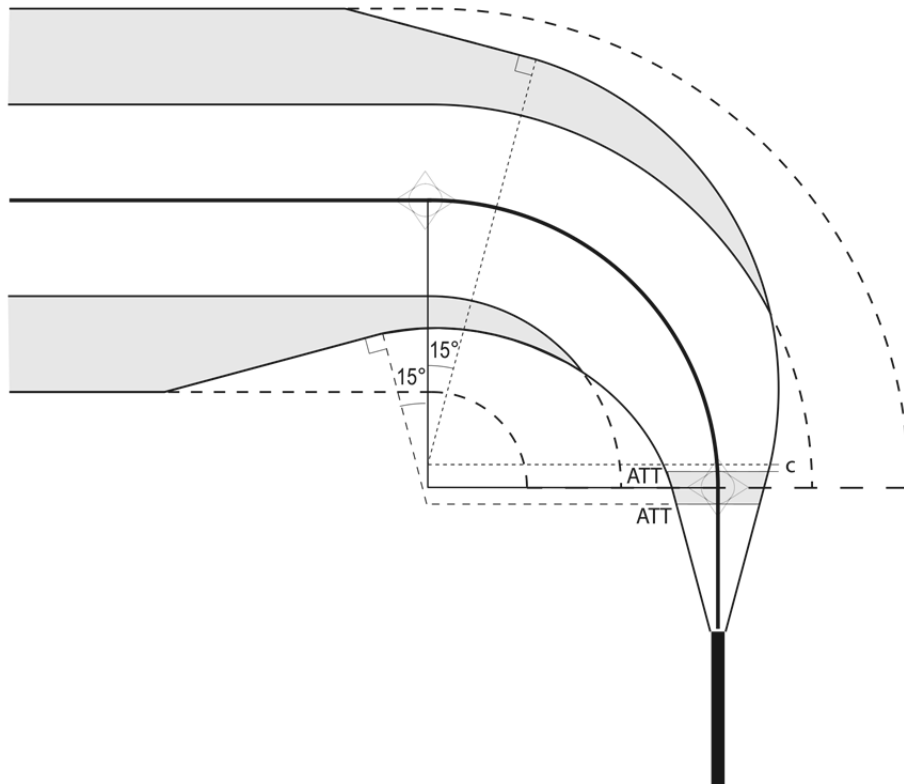

Figure III-2-2-14. Splay in RF turn

...

Section 3 PROCEDURE CONSTRUCTION

...

Chapter 1 DEPARTURE PROCEDURES

1.1 GENERAL

1.1.1 Application

1.1.1.1 This chapter describes the departure criteria for ~~RNAV 1, RNAV 2 and Basic RNP-1~~ PBN procedures (see Table III-1-1-1).

1.1.1.2 The general criteria of Part I, Section 3 and Part III, Sections 1 and 2 as amplified or modified by the criteria in this chapter apply to ~~RNAV and RNP-PBN~~ departure procedures.

...

1.1.4 Area widths

1.1.4.1 ~~For RNAV 1, RNAV 2 and Basic RNP-1, the~~ The total area width results from joining the various area widths at the relevant fixes. For the calculation of area widths and the underlying tolerances involved in these calculations, see the paragraph entitled “XTT, ATT and area semi-width” in Section 1 for the appropriate sensor. These are:

- a) DME/DME, Section 1, Chapter 3, 3.6;
- b) ~~basic~~-GNSS, Section 1, Chapter 2, 2.2; ~~and~~
- e) ~~SBAS, Section 1, Chapter 5, 5.1.2.~~

Notes.—

- ~~1. Multi-sensor solutions involving the use of VOR/DME may be developed for specific scenarios. In such cases, Section 1, Chapter 4 applies.~~
- ~~2. SBAS departure criteria detailed in Section 1, Chapter 5, 5.1.2 were developed prior to the PBN concept and are retained pending the introduction of a relevant navigation specification.~~
- ~~3. For pre-PBN RNP applications (see Section 1, Chapter 7), when the promulgated RNP value decreases at a point in the procedure, the total area width as defined in Section 1, Chapter 7, 7.5, “XTT, ATT and area semi-width” decreases from the initial value to the final value in accordance with the methodology detailed in Section 1, Chapter 1, 1.4.~~

...

1.3 AREA WIDTH AT THE BEGINNING OF THE DEPARTURE

1.3.1 For the construction of the area width at the beginning of the departure, the general criteria apply (see Part I, Section 3) until the splaying boundaries reach the outer boundary of the fictitious area (see Figure ~~III-3-1-1~~ III-3-1-2) from where it follows the width of the fictitious area until the first waypoint of the departure procedure. The fictitious area begins at the DER and extends to the first waypoint. The area semi-width of this area at the DER and at the first waypoint varies according to sensor type (see Table III-3-1-1).

1.3.2 After the initial splay at the DER, the area width changes at 15 NM from the DER and then at 30 NM from the ARP. At each change, a 15° splay on either side of track is used in accordance with the methodology detailed in Section 1, Chapter 1, 1.4.3. See Figure ~~III-3-1-1~~ III-3-1-2.

1.4 TURNING DEPARTURES

1.4.1 General

1.4.1.1 Four kinds of turns can be prescribed:

- a) turn at a “fly-by” waypoint;
- b) turn at a “flyover” waypoint (which corresponds to a turn at a designated TP);
- c) turn at an altitude/height; and
- d) fixed radius (RF) turns.

Note. ~~The RF functionality is not required in RNAV 1, RNAV 2 or Basic RNP-1. It is a recommended function in some regional applications (e.g. P RNAV). If a State wishes to apply RF turns, it needs to be addressed in national standards and suitably indicated in the AIP and on the chart. Charting criteria can be found in Part 3, Section 5.~~

~~1.4.1.2 Wherever obstacle clearance and other considerations permit, turn at a “fly-by” waypoint is preferred.~~

~~1.4.1.3~~ 1.4.1.2 In For fly-by and fly-over turns, in order for the aircraft to properly execute the turn, each single specified turn should be at least 5° and must not exceed 120°. However, the maximum value of 120° does not apply to the case of a turn (at either altitude/height or at a designated TP) with a free turn back to a waypoint. An RF turn shall be between 2° and 358°

1.4.1.3 Modified straight departure criteria are applied to any Radius to Fix (RF) leg. The design methodology for RF turns on departure is as follows:

- a) During the initial departure, as GNSS is used, the ATT value at any point along the path is reduced in proportion to the area semi-width value (as determined by the splay) as derived from the following formula, using SI units:

$$\text{Reduced ATT} = \left\{ \frac{ATT}{\frac{\frac{1}{2} AW - 150}{\tan 15^\circ}} \right\} x + 120$$

Where x is the distance, in metres, from the DER;
 ATT is the full value appropriate to the RNP accuracy; and
 120 m represents the reduced ATT at the DER.

The ATT value is not reduced if the initial departure is based upon other positioning sources.

- b) The minimum distance from the DER to the waypoint at the start of the RF turn shall be 1 852 m (1 NM). If the OIS does not reach 400 ft above DER prior to the earliest ATT at the start of the RF leg, an additional climb gradient shall be published, from a point 35 ft above the DER to at least 400 ft above the DER at the earliest ATT, and an appropriate altitude restriction shall be published at the waypoint.
- c) The track length from the DER to the end of the RF shall be calculated along the nominal track based upon a nominal radius.
- d) The height above aerodrome and the associated design IAS value at the end of the RF leg shall be based upon a climb gradient along the nominal track as determined by the designer but not lower than 10 per cent. A speed limit may be promulgated for the end of the RF leg if a smaller radius is required.
- e) The TAS at the end of the RF shall be calculated using the appropriate maximum temperature value above ISA for the aerodrome. The appropriate wind value shall be added to the TAS prior to calculating the actual radius of turn.
- f) If the MOC is less than or equal to 90m, as defined in Part I, Section 3, Chapter 2, the OIS is lowered to take account of body geometry (BG) from a point “ATT” prior to the start of the RF leg. The OIS is kept level from that point until BG protection has been reached. The 0.8 per cent D + BG OIS is maintained during the RF turn until 90 m MOC is reached.

$$BG = \text{wing semi-span} * \sin(\alpha + 5)$$

Where α is the angle of bank
 wing semi-span = 40m (132 ft)

This is illustrated in Figure III-3-1-1.

- g) The 2.5 per cent OIS gradient is based upon the track between the two waypoints defined by a radius of $r - 186$ m ($r - 0.1$ NM) with a PDG of 3.3 per cent.

1.4.2 Turn protection

For turn protection at a fly-by, flyover, turning altitude/height or ~~fixed radius~~ RF turn, see Section 2, Chapter 2, “Turn protection and obstacle assessment.”

...

1.4.3 Promulgation

The following criteria apply to RF turns on departures:

- If the OIS does not reach 400 ft at the start of the RF turn, an additional gradient and an altitude restriction at the waypoint shall be published.
- The path descriptor sequence for initial legs should be IF/TF/RF/TF or IF/TF/RF/RF/TF.

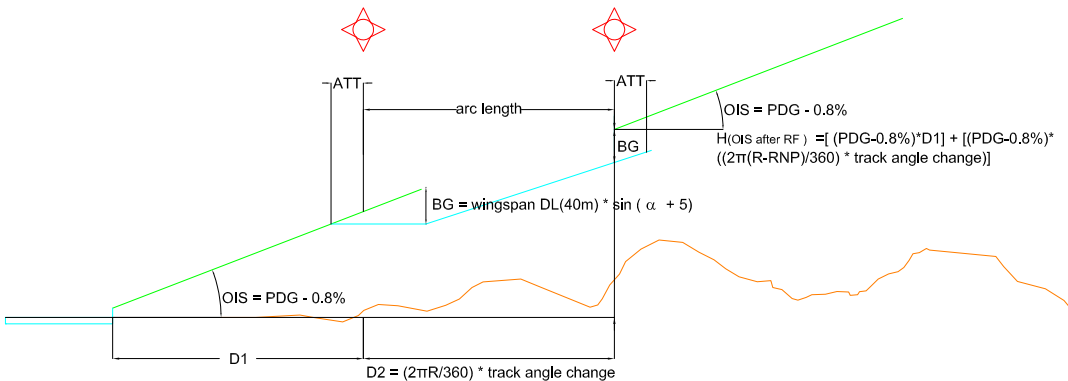

Figure III-3-1-1. RF initial departure

Editorial note.— Re-number subsequent figure accordingly.

...

Chapter 2 ARRIVAL AND APPROACH PROCEDURES

2.1 GENERAL

2.1.1 Application

2.1.1.1 This chapter describes the arrival, initial and intermediate approach and final missed approach criteria for ~~RNAV 2, RNAV 1, Basic RNP 1 and RNP APCH PBN~~ procedures (see Table III-1-1-1). The criteria for the final approach, initial and intermediate missed approach are specific to the approach classification (NPA, APV and precision) and are dealt with in separate chapters.

Note.— The criteria for RNP AR APCH procedures are detailed in the Required Navigation Performance Authorization Required (RNP AR) Procedure Design Manual (Doc 9905).

2.1.1.2 The general criteria of Part I and Part III, Sections 1 and 2, as amplified or modified by the criteria in this chapter, apply to ~~RNAV and RNP PBN~~ arrival and approach procedures.

...

2.1.4 Area widths

2.1.4.1 For the calculations of area widths and the underlying tolerances involved in these calculations, see the paragraph entitled “XTT, ATT and area semi-width” in Section 1 for the appropriate sensor. These are:

- a) DME/DME, Section 1, Chapter 3, 3.6;
- b) ~~basic~~-GNSS, Section 1, Chapter 2, 2.2; and
- c) ~~SBAS, Section 1, Chapter 5, 5.2.3.~~

...

2.4 INTERMEDIATE APPROACH SEGMENT

2.4.1 Intermediate approach alignment

2.4.1.1 For non-precision approach procedures, the intermediate approach segment should be aligned with the final approach segment whenever possible. If a turn at the FAF is required, the angle shall not exceed 30° (Cat H, 60°) on a fly-by turn. If the intermediate segment contains an RF leg, the criteria in paragraph 2.4.1.4 apply.

2.4.1.2 ~~For approach procedures with vertical guidance and precision approach procedures the intermediate approach segment shall be aligned with the final approach segment.~~ For approach procedures with barometric vertical guidance, the intermediate segment should be aligned with the final approach segment. If a fly-by turn at the FAF is required, the angle shall not exceed 15°.

2.4.1.3 For SBAS APV and CAT I approach procedures the intermediate segment shall be aligned with the final approach segment.

2.4.1.4 If the intermediate segment contains an RF segment that ends at the FAF, the following criteria apply:

- a) the track angle change of the RF leg shall not exceed 45°; and
- b) the minimum radius shall be 4 723 m (2.55 NM).

2.4.1.5 For precision approach procedures other than SBAS CAT I, the intermediate approach segment shall be aligned with the final approach segment.

2.4.2 Intermediate approach length

2.4.2.1 The intermediate segment ~~may consist~~ with a fly-by turn at the IF consists of two components:

- a) a turning component (where used) followed by

- b) a straight component immediately before the final approach waypoint.

2.4.2.2 ~~The length of the straight component is variable but will not be less than 3.70 km (2.00 NM). This allows the aircraft to be stabilized prior to overflying the final approach waypoint. The length of the turning component is the minimum stabilization distance for the turn angle at the IF and can be determined from Section 2, Chapter 1, Table III-2-1-3 or III-2-1-9. When an RF is used in the intermediate segment, the total length of the intermediate segment, including curved and straight legs, shall not be less than 3 704 m (2 NM).~~

- 2.4.2.3 For GBAS specific criteria apply (see Chapter 6).

2.4.3 Intermediate approach area width

~~DME/DME, Basic and GNSS and RNP.~~ The total area width results from joining the area widths at the IF and the FAF. The principle of secondary areas applies.

~~Note. Not applicable when a change of RNP value occurs at the intermediate fix.~~

...

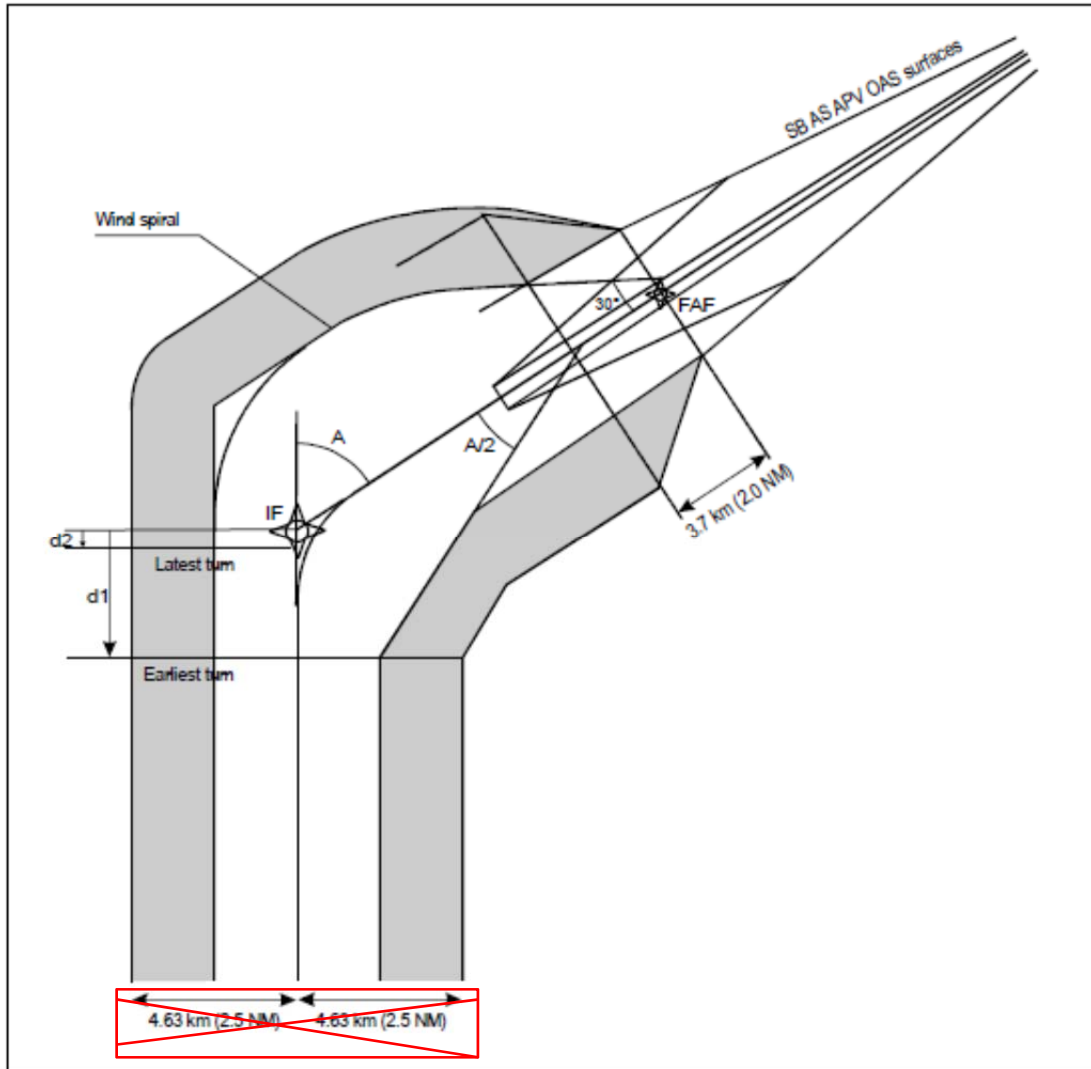

...

Chapter 3 NON-PRECISION APPROACH PROCEDURES

...

3.3.5 Missed approach area width for SBAS

...

3.3.5.2 *Turning missed approach*

At the earliest turning point of a turning missed approach the system reverts to terminal mode. Therefore, for succeeding segment the area semi-width is equal to 4.63 km (2.5 NM) up to 15 NM from the ARP and then 4 630 m (2.5 NM) thereafter.

...

**Chapter 7
HOLDING PROCEDURES**

7.1 GENERAL

...

7.1.2.1 *Navigation specifications requiring RNAV systems with holding functionality.* Aircraft equipped with RNAV systems have the flexibility to hold on tracks which are defined by the RNAV equipment and to use procedures which are less rigid than those used in conventional holdings. The benefits of using this technique include the optimum utilization of airspace with regard to the siting and alignment of holding areas as well as, under certain circumstances, a reduction of holding area airspace. The only navigation specification requiring an area navigation system with a holding functionality is advanced RNP.

Note.—A navigation specification requiring RNAV systems with holding functionality is currently under development.

7.1.2.2 *Navigation specifications not requiring RNAV systems with holding functionality.* For RNAV systems without any holding functionality it is possible to define an RNAV holding procedure, to be flown manually, based on a waypoint. A conventional holding template shall be used to construct the obstacle clearance area for this type of holding. ~~Navigation specifications not requiring RNAV systems with holding functionality are RNAV 1 and 2, Basic RNP 1, RNP APCH and RNP AR APCH.~~

...

Editorial note.— Delete paragraph 7.6 in toto and delete Figures III-3-7-3 and III-3-7-4 accordingly.

~~7.6 HOLDING AREA CONSTRUCTION FOR RNP~~

...

<p><i>Origin:</i> <i>IFPP / Secretariat</i></p>	<p><i>Rationale</i></p> <p>The fourth edition of the PBN Manual introduces four new navigation specifications and various new functional requirements. In order to support the implementation of these new specifications, these must be supported by inclusion of the appropriate PBN design criteria in the PANS-OPS. The application of these new navigation specifications will bring safety, airspace capacity, airport access and environmental benefits.</p>
---	---

PBN — BARO-VNAV

Part III

...

Section 3
PROCEDURE CONSTRUCTION

...

Editorial note.— Replace Part III, Section 3, Chapter 4 by the following new text and keep the existing Appendices to Chapter 4.

Chapter 4
APV/BAROMETRIC VERTICAL NAVIGATION
(BARO-VNAV)

Note 1.— This chapter is based on, and applicable for, aircraft meeting the APV/Baro-VNAV criteria as laid down in the Performance-based Navigation (PBN) Manual, Volume II, Appendix A (Doc 9613).

Note 2.— In this chapter, distances and heights related to obstacle clearance surfaces are all in SI units. Distances and heights are measured relative to threshold (positive before/above threshold, negative after/below threshold). If non-SI units are required, the appropriate conversions must be made as in the GBAS criteria (see Chapter 6).

4.1 GENERAL

4.1.1 This chapter describes the vertical component of the APV/Baro-VNAV procedure criteria. The general criteria and Sections 1, 2 and 3, as amplified or modified by criteria in this chapter, apply.

4.1.2 Baro-VNAV approach procedures are classified as APV procedures in support of Type A 3D approach operations. They utilize a DA/H and not an MDA/H, and neither a FAF nor a missed approach point (MAPt) is identified. They use obstacle assessment surfaces similar to those for ILS, but based on the specific lateral guidance system.

4.1.3 Baro-VNAV procedures are used in association with LNAV-only procedures. The LNAV-only FAF and MAPt are needed to define the lateral areas and to support the lateral guidance but they are not used for the Vertical Navigation function.

Note.— The criteria associated with the lateral navigation performance (LNAV) are based on the RNP APCH criteria detailed in Chapter 3.

4.1.4 Baro-VNAV procedures shall not be authorized with a remote altimeter setting.

Note.— A remote altimeter-setting source may be charted for the associated LNAV-only procedure.

4.2 STANDARD CONDITIONS

4.2.1 Vertical Path Angle (VPA)

4.2.1.1 The effective VPA will differ from the promulgated VPA as it is dependent upon temperature and aerodrome elevation. The optimum VPA is 3°. The promulgated VPA shall be such that the effective VPA throughout the year is as close as possible to 3.0° for the given aerodrome elevation and prevailing temperatures. See Table III-3-4-1 to determine the optimum promulgated VPA. The following conditions apply:

- the effective VPA at the lowest prevailing temperature shall remain greater than or equal to 2.5°;
- the effective VPA at the highest prevailing temperature should remain less than or equal to 3.5°.

4.2.1.3 A procedure shall not have a promulgated VPA that is less than 2.5°. A procedure with a promulgated VPA that exceeds 3.5° is a non-standard procedure. It shall be subject to an aeronautical study and will require special approval by the national competent authority (see Part I, Section 4, Chapter 5.3.1.2 and Appendix B to Chapter 5).

Table III-3-4-1: Effective vs promulgated VPA as a function of aerodrome elevation and temperature (Green optimum; Yellow non-standard; Orange prohibited)

Temp (°)	Promulgated VPA 2.8°			Promulgated VPA 3.0°			Promulgated VPA 3.2°		
	Aerodrome elevation			Aerodrome elevation			Aerodrome elevation		
	MSL	3 000 ft	6 000 ft	MSL	3 000 ft	6 000 ft	MSL	3 000 ft	6 000 ft
50	3.11	3.15	3.20	3.33	3.38	3.43	3.55	3.60	3.66
40	3.02	3.07	3.13	3.24	3.29	3.35	3.46	3.51	3.57
30	2.94	3.00	3.04	3.15	3.21	3.26	3.36	3.42	3.48
20	2.85	2.90	2.96	3.05	3.11	3.17	3.25	3.32	3.38
10	2.75	2.81	2.87	2.95	3.01	3.07	3.15	3.21	3.27
0	2.64	2.71	2.76	2.83	2.90	2.96	3.02	3.09	3.16
-10	2.53	2.59	2.66	2.71	2.78	2.85	2.89	2.97	3.04
-20	2.41	2.48	2.55	2.58	2.66	2.73	2.75	2.84	2.91
-30	2.28	2.35	2.43	2.44	2.52	2.60	2.60	2.69	2.77
-40	2.14	2.21	2.29	2.29	2.37	2.45	2.44	2.53	2.61
-50	1.98	2.06	2.15	2.12	2.21	2.30	2.26	2.36	2.45

4.2.2 The reference datum height should be 15 m (50 ft).

4.2.3 All obstacle heights shall be referenced to threshold elevation.

4.3 APV SEGMENT

4.3.1 General

The APV segment for the Baro-VNAV approach contains the final descent segment for landing, and the initial and intermediate segments of the missed approach. It shall be aligned with the extended runway centre line. A turn at the FAF of up to 15° is allowed.

4.3.2 APV OAS

The APV OAS starts at the final approach point (FAP), which is located at the intersection of the vertical path and the procedure altitude specified for the preceding segment in ISA conditions. The FAP should not be located more than 19 km (10 NM) before the threshold. The APV OAS ends at the MAHF, MATF or the turn altitude, whichever comes first. The LNAV missed approach criteria apply after the end of the APV OAS. The LNAV FAF and MAPt are used to define the geometry of the areas and surfaces, to define any underlying LNAV procedure and for database coding purposes.

4.3.3 Frame of reference

See Chapter 6, 6.4.8.2, “Frame of reference”.

4.3.4 Definition of the OAS

4.3.4.1 The OAS are used to identify accountable obstacles and consist of the following surfaces:

- a) final approach surface (FAS);
- b) ground plane; and
- c) missed approach surface (Z surface).

The final approach surface is bounded laterally by the edges of the LNAV primary area. Each surface has associated side surfaces. The upper/outer edges of the APV-OAS side surfaces are laterally coincident with the outer edges of the LNAV secondary areas. The lower/inner edges of the APV-OAS side surfaces are laterally coincident with the edges of the LNAV primary area (see Figures III-3-4-1 and III-3-4-2).

4.3.4.2 *Final approach surface.* The origin of the final approach surface (FAS) is at threshold level and is located at a distance of 444 m (ATT) prior to the point where the promulgated vertical path reaches a specified height above the threshold. This height, H_i is an altitude dependent value throughout the final approach segment (see below). The final approach surface extends up to the intersection with the horizontal OCS of the intermediate segment. This intersection may occur before or after the FAP. When this intersection is after the FAP, the OCS of the intermediate segment continues within the final approach segment and becomes the final approach OCS up to the point where it intersects the final approach surface.

The value of H_i is as follows:

- a) H_0 = 75 m below 5 000' AMSL,
- b) H_{5000} = 105 m between 5 000' and 10 000' AMSL and
- c) H_{10000} = 120 m at or above 10 000' AMSL.

For detailed rules of the application of H_i see paragraphs 4.3.4.2.4 and 4.3.4.2.5, and Figure III-3-4-4.

4.3.4.2.1 The determination of the VPA may require an iterative process. Initially, a VPA is selected based upon paragraph 4.2.1. The design is carried out and the OCA/H is calculated using this VPA and the minimum useable temperature is determined. If the result is satisfactory, the VPA, OCA/H and minimum temperature are promulgated. If not, then the VPA and the minimum temperature are adjusted until an optimum solution is found.

4.3.4.2.2 *Determination of minimum promulgated temperature.* The minimum promulgated temperature depends upon the minimum VPA (the temperature correction is obtained from Appendix A to this chapter) as follows:

- a) The minimum VPA for the proposed minimum promulgated temperature shall be calculated. If the minimum VPA is less than 2.5° , either the promulgated VPA shall be increased to ensure the minimum VPA is equal to or greater than 2.5° , or the minimum promulgated temperature for the procedure shall be increased; and
- b) The length of the preceding segment shall be reviewed to ensure it meets the relevant requirements for minimum distance before vertical path intercept.

Note 1.— The minimum temperature to be promulgated is an optimum balance between runway availability due to weather (visibility and cloud ceiling) and cold temperature.

Note 2.— No minimum temperature restrictions apply to aircraft with avionics incorporating approved final approach temperature compensation, provided the minimum temperature is not below that for which the equipment is certificated, or to SBAS avionics approved to fly Baro-VNAV procedures.

4.3.4.2.3 *Final approach side surfaces.* The lower/inner edges of the final approach side surfaces are defined by the edges of the FAS. The outer edges of the final approach side surfaces are defined by the edges of the LNAV secondary area at H_i above the FAS.

4.3.4.2.4 *Approach surfaces above 5 000 ft* (see Figure III-3-4-4). When the horizontal OCS of the intermediate segment is above 5 000 ft AMSL, the FAS above 5 000 ft is replaced by a revised final approach surface, FAS', between 5 000 ft and 10 000 ft and by a revised final approach surface, FAS'', above 10 000 ft. The surfaces FAS'', FAS' and FAS are connected by horizontal planes at 10 000 ft and 5 000 ft respectively.

$X_{FAS'}$ and $\tan\alpha_{FAS'}$ are calculated according to the formula in paragraph 4.3.4.2.5 and applying a $H_{5\,000}$ of 105 m.

$X_{FAS''}$ and $\tan\alpha_{FAS''}$ are calculated according to the formula in paragraph 4.3.4.2.5 and applying a $H_{10\,000}$ of 120 m.

The outer edges of the final approach side surfaces associated with FAS' are defined by the edges of the LNAV secondary areas at 105 m above FAS'. The outer edges of the final approach side surfaces associated with FAS'' are defined by the edges of the LNAV secondary areas at 120 m above FAS''.

The outer edges of the side surfaces associated with the horizontal planes connecting FAS'', FAS' and FAS are reduced from 120 m to 105 m and from 105 m to 75 m, respectively. This result in twisted side surfaces associated with the horizontal planes.

4.3.4.2.5 Calculation of FAS angle, FAS origin and FAS Height

The angle of the FAS (α_{FAS}) shall be determined as follows:

$$\tan \alpha_{FAS} = (\text{height at FAP} - \Delta h - H_i) * \tan VPA / (\text{height at FAP} - H_i)$$

(see Appendix A and Figure III-3-4-3)

The origin of the FAS at threshold level shall be determined as follows:

$$X_{FAS} = [(H_i - RDH) / \tan VPA] + ATT$$

The height of the FAS (h_{FAS}) at range x relative to threshold shall be determined as follows:

$$h_{FAS} = (x - X_{FAS}) * \tan \alpha_{FAS} \text{ up to 5 000 ft or intermediate segment OCS, whichever is smaller}$$

4.3.4.2.6 *FAS elevation above 5 000 ft and 10 000 ft.* Where the calculation of h_{FAS} results in a FAS elevation above 5 000 ft AMSL then, from that x coordinate onwards, H_0 of 75 m shall be replaced by $H_{5\,000}$ of 105 m. In such a case, $\tan \alpha_{FAS}'$, X_{FAS}' and h_{FAS}' shall be recalculated by applying 105 m ($H_{5\,000}$). If h_{FAS}' results in a FAS' elevation below 5 000 ft AMSL, then the FAS' elevation is set at 5 000 ft AMSL at x . If h_{FAS}' results in a FAS' elevation above 5 000 ft (but below 10 000 ft AMSL), then h_{FAS}' is the FAS' elevation at x (See 4.3.4.2.4 and Figure III-3-4-4). A similar recalculation shall be carried out if the application of 105 m ($H_{5\,000}$) results in a FAS'' elevation above 10 000 ft.

4.3.4.3 *Ground plane.* The ground plane is defined by a surface at threshold level bounded by the LNAV primary area between the origin of the FAS (see 4.3.4.2.5) and the origin of the missed approach Z surface (X_z). The lower/inner edges of the ground plane side surfaces are defined by the edges of the LNAV primary area at threshold level. The upper/outer edges of the side surfaces are defined by the outer edges of the LNAV secondary areas at the height of H_i above threshold at the origin of X_{FAS} and the outer edges of the LNAV area, reducing to 30 m above threshold at ATT before threshold and continuing at 30 m above threshold up to X_z .

4.3.4.4 Missed approach (Z) surface

4.3.4.4.1 The origin of the missed approach surface (X_z) is at threshold level between -900 and -1400 m relative to threshold. It has a nominal gradient of 2.5 per cent. If an operational benefit can be realized by promulgating missed approach climb gradients greater than the nominal 2.5 per cent, the Z surface and associated side surfaces may be adjusted for higher gradients. If an OCA/H for a missed approach gradient higher than 2.5 per cent is published, the OCA/H for a missed approach gradient of 2.5 per cent shall also be published. The Z surface is bounded laterally by the LNAV primary area. The lower/inner edges of the associated side surfaces are defined by the edges of the LNAV missed approach primary area and the outer edges of the LNAV secondary areas 30 m above the missed approach (Z) surface.

4.3.4.4.2 The origin of the Z surface depends upon the category of aircraft as follows:

- a) CAT A and B: $X_z = -900$ m
- b) CAT C: $X_z = -1100$ m
- c) CAT D: $X_z = -1400$ m

4.3.4.4.3 For an airfield elevation higher than 900 m (2 953 ft) or a promulgated VPA above 3.2°, the origin of the Z surface (X_z) shall be determined by applying the following formula:

$$X_z = \text{MIN} [\text{Value tabulated in 4.3.4.4.2, } (HL-RDH)/\tan VPA - (ATT + 2 * TAS * \sin VPA / \gamma * (TAS + V_w))]]$$

Where :

HL = height loss

VPA = promulgated VPA

TAS = Maximum true airspeed based on the highest final approach speed for each aircraft category (see Tables I-4-1-1 and I-4-1-2) at the aerodrome elevation with a temperature of ISA + 15°C.

γ = vertical deceleration [0.08g (2.56 ft/sec²)]

$V_w = 10$ kt

4.3.5 Termination of the APV segment

The APV segment terminates at the earliest MAPt if a turn is specified at the MAPt, at the earliest MATF or the K-K line for a turn at an altitude, or the MAHF, whichever is earliest. In any case the earliest turning point shall not be before the SOC. In case of a turn at the MAPt, the lowest possible OCH is the height loss above the height of the VPA' plane at the earliest MAPt.

4.4 DETERMINATION OF OCH FOR THE APV SEGMENT

4.4.1 Categorization of obstacles

Accountable obstacles are divided into approach and missed approach obstacles. The standard method of categorization is as follows:

- a) Approach obstacles are those located between the beginning of the final approach segment and the origin of the Z surface.
- b) Missed approach obstacles are those located in the remainder of the missed approach segment (see Figure III-3-4-5 a)).

Obstacles located before the origin of the Z surface may be considered as missed approach obstacles if they penetrate a surface VPA', parallel to the promulgated VPA and with origin at X_z. [i.e. obstacle height greater than [(x-X_z) tanVPA] (see Figure III-3-4-5 b)).

4.4.2 Approach obstacles

4.4.2.1 For final approach obstacles penetrating the FAS or the ground plane, the final approach OCH shall be determined by adding the category related height loss margin (see 4.5) to the height of the obstacle.

4.4.2.2 For final approach obstacles penetrating the final approach side surface or the side surface associated with the ground plane, the final approach OCH shall be determined by adding a value, reduced linearly from the full height loss value at the inner edge of the side surface to zero at the outer edge of the side surface, to the height of the obstacle.

4.4.3 Missed approach obstacles

4.4.3.1 For missed approach obstacles penetrating a final approach surface, the ground plane or the Z surface, the height of equivalent approach obstacle shall be calculated using the following formula:

$$h_a = \frac{h_{ma} \cdot \cot Z + (X - X_z)}{[\cot Z + \cot \theta]}$$

where:

- h_a = height of the equivalent approach obstacle
- h_{ma} = height of the missed approach obstacle
- $\cot Z$ = cotangent of the Z surface angle
- $\cot \theta$ = cotangent of the VPA
- X_z = X coordinate of the intermediate missed approach surface (Z)

4.4.3.2 For missed approach obstacles penetrating a side surface the height of equivalent approach obstacle shall be calculated using the following formula:

$$h_a = \frac{h'_{ma} \cdot \cot Z + (X - X_z)}{\cot Z + \cot \theta}$$

where h'_{ma} is the amount of the penetration plus the height of the inner edge of the side surface at the along-track distance of the penetrating obstacle (see Figure III-3-4-6).

4.4.3.3 The missed approach OCH is determined by adding the applicable Height Loss to the highest equivalent obstacle height, h_a , calculated according to 4.4.3.1 and 4.4.3.2

4.4.4 Obstacle clearance height

The OCH of the approach is the maximum value of the final approach OCH and the missed approach OCH determined according to 4.4.2 and 4.4.3.

4.5 HEIGHT LOSS MARGINS

4.5.1 The height loss margins using a pressure altimeter shall be applied to all approach and equivalent approach obstacles. They are detailed in Table III-3-4-2:

Aircraft category (V_{at})	Margin using radio altimeter ¹⁾		Margin using pressure altimeter	
	Meters	Feet	Meters	Feet
A – 169 km/h (90 kt)	13	42	40	130
B – 223 km/h (120 kt)	18	59	43	142
C – 260 km/h (140 kt)	22	71	46	150
D – 306 km/h (165 kt)	26	85	49	161

Table III-3-4-2. Height loss margins

¹⁾ The radio altimeter margins are reproduced for the corrections to steep angles and high airports only and not for the derivation of the OCH.

4.5.2 Adjustments for high airfield elevations and steep angles

4.5.2.1 *High airfield elevations.* The values in Table III-3-4-2 shall be adjusted for airfield elevations higher than 900 m (2 953 ft). The tabulated allowances shall be increased by 2 per cent of the radio altimeter margin per 300 m (984 ft) airfield elevation.

4.5.2.2 *Steep angle approaches.* In exceptional cases, for approach angles greater than 3.2°, the allowances shall be increased by 5 per cent of the radio altimeter margin per 0.1° increase in glide path angle between 3.2° and 3.5°.

4.5.3 Adjustment for aircraft with non-standard height loss values

The values in Table III-3-4-2 are calculated to account for aircraft using normal manual overshoot procedures from OCA/H on the nominal approach path. Values in the table may be adjusted for specific aircraft types where adequate flight and theoretical evidence is available, i.e., the height loss value corresponding to a probability of 1×10^{-5} (based on a missed approach rate 10^{-2}).

4.5.4 Margins for specific V_{at}

If a height loss/altimeter margin is required for a specific V_{at} , the following formulae shall apply (see also Table II-1-1-4):

$$\text{Margin} = (0.068 V_{at} + 28.3) \text{ meters where } V_{at} \text{ in km/h}$$

$$\text{Margin} = (0.125 V_{at} + 28.3) \text{ meters where } V_{at} \text{ in kt}$$

where V_{at} is the speed at threshold based on 1.3 times stall speed in the landing configuration at maximum certificated landing mass

Note.— The equations assume the aerodynamic and dynamic characteristics of the aircraft are directly related to the speed category. Thus, the calculated height loss/altimeter margins may not realistically represent small aircraft with VAT at maximum landing mass exceeding 165 kt.

4.6 PROMULGATION

4.6.1 The general criteria in Part I, Section 4, Chapter 9, 9.5, “Procedure naming for arrival and approach charts” apply. The instrument approach chart shall be entitled “RNAV Rwy XX”. The minimum box on the chart shall include OCA/H values for NPA (LNAV) and APV/Baro-VNAV (LNAV/VNAV) operations.

4.6.2 OCA/H shall be published in accordance with Part I, Section 4, Chapter 5, 5.5, “Promulgation”. In no case will the OCA/H be lower than the values given in 4.1.5.

4.6.3 In addition, the following shall be promulgated:

- a) RDH;
- b) VPA (degrees and hundredths of a degree for databases/degrees and tenths of a degree for charting);
- c) the minimum temperature for which APV/Baro-VNAV operations are authorized;
- d) the temperature above which the effective VPA will exceed 3.5°; and
- e) for database coding purposes only, the LNAV, FAF and MAPt.

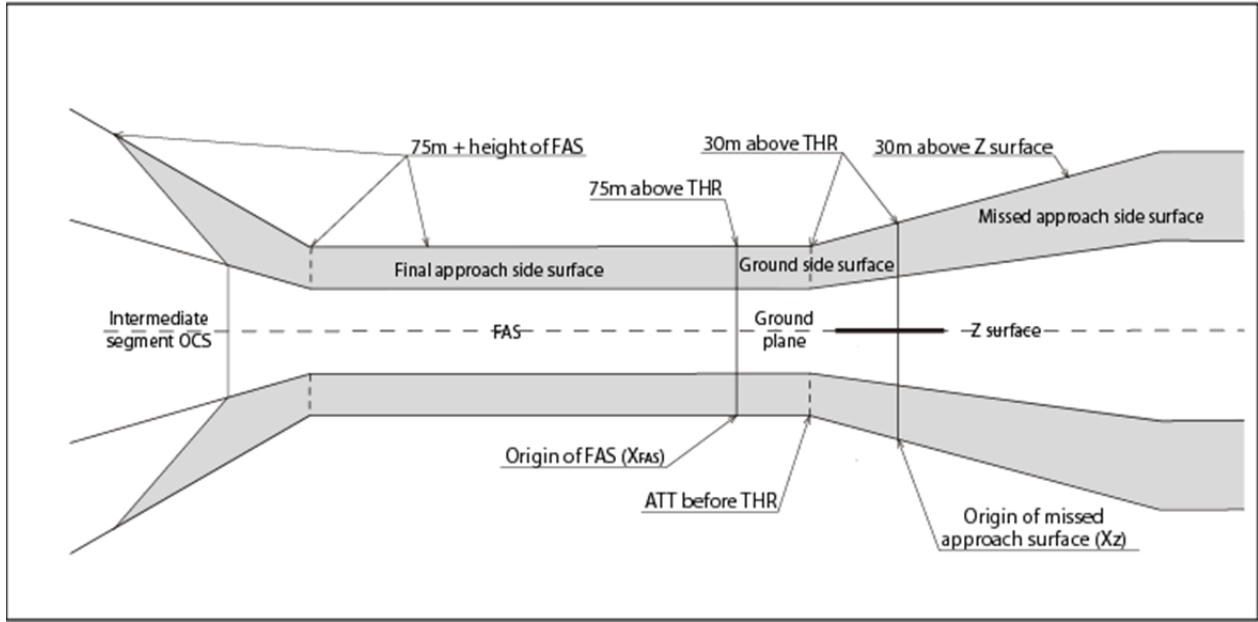

**Figure III-3-4-1. APV/Baro-VNAV area — APV OAS in plan view
(aerodrome and intermediate segment OCS at or below 5 000 ft)**

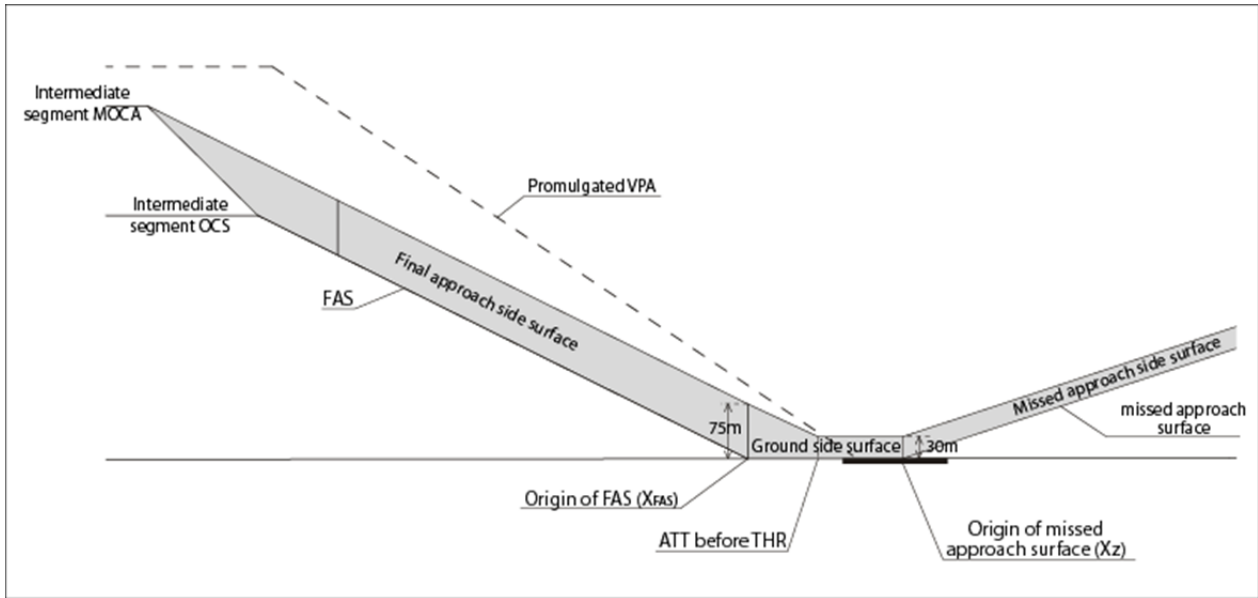

**Figure III-3-4-2. Baro-VNAV OAS — Profile view
(aerodrome and intermediate segment OCS at or below 5 000 ft)**

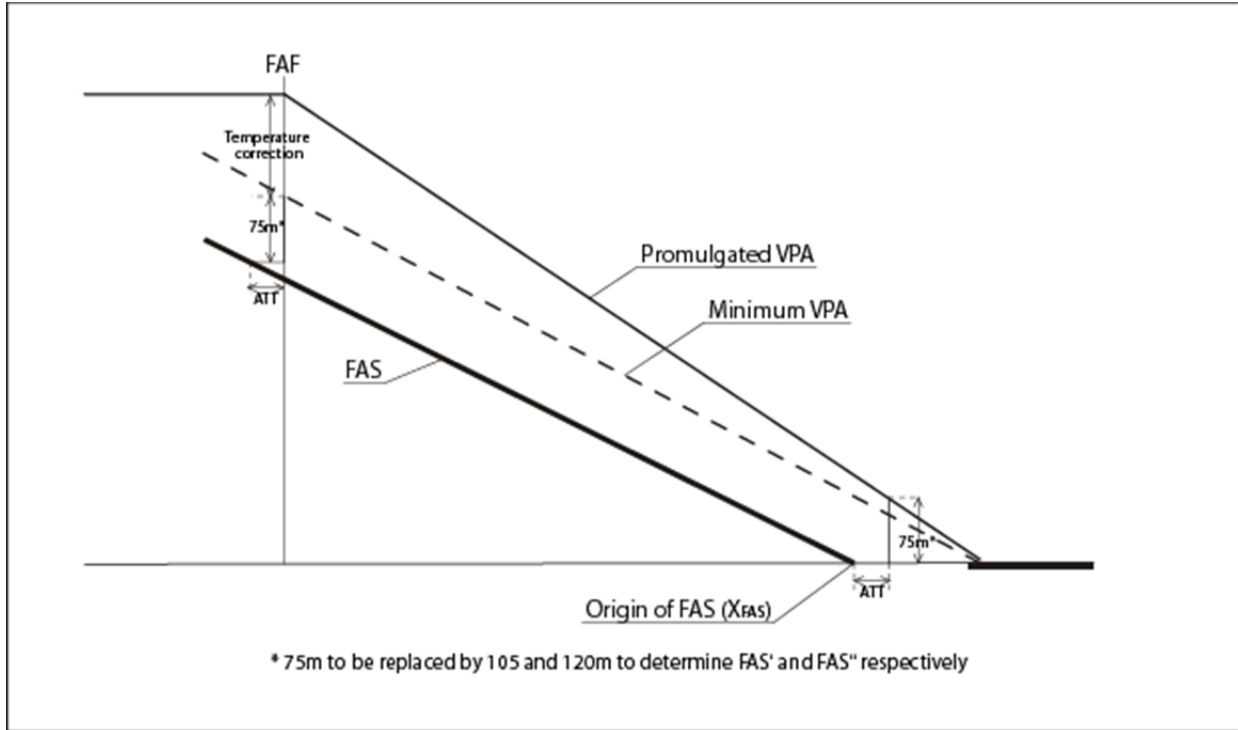

Figure III-3-4-3. VNAV final approach surface and minimum VPA

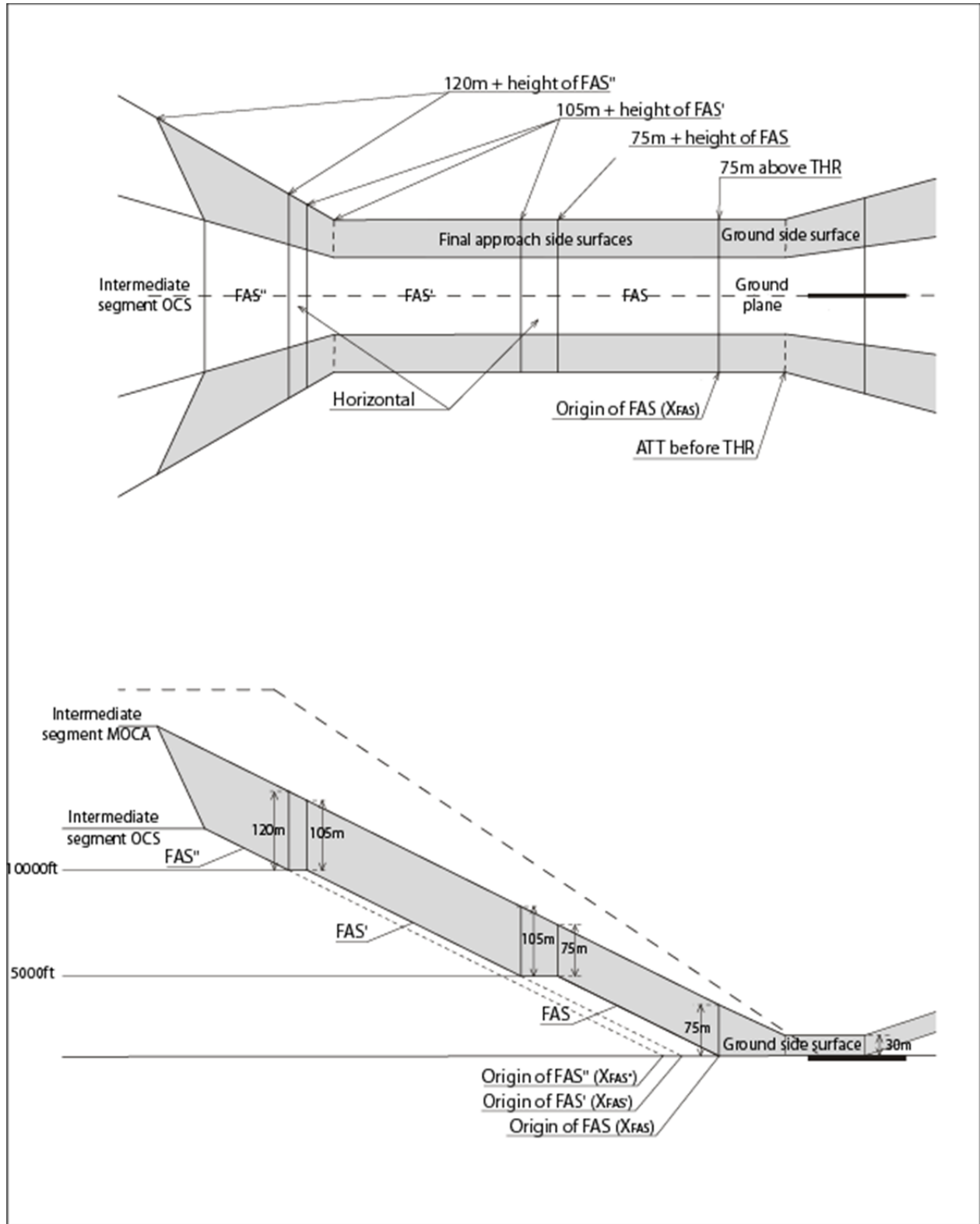

Figure III-3-4-4. Final approach surfaces above 5 000 ft

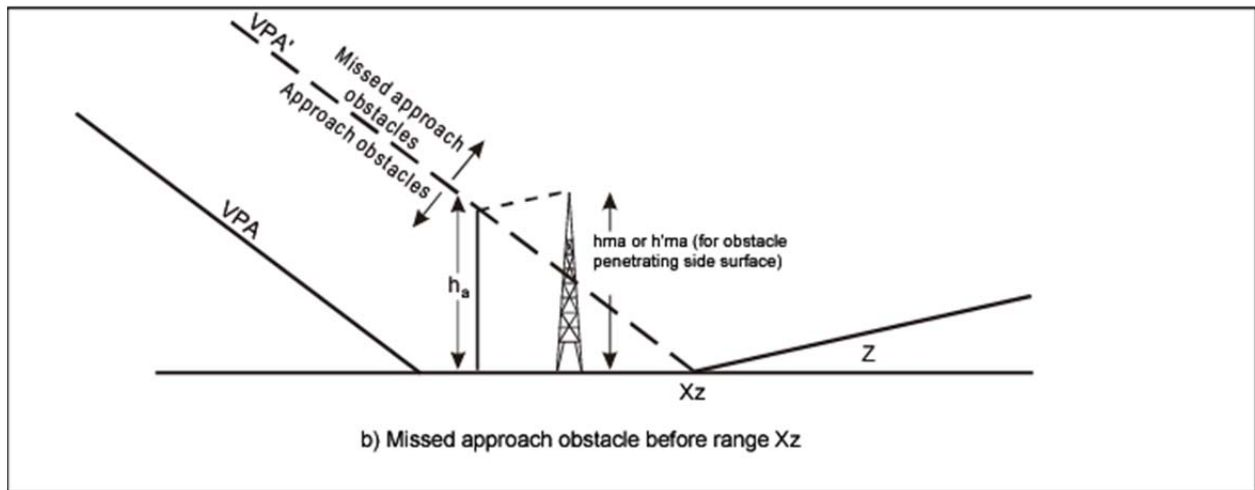
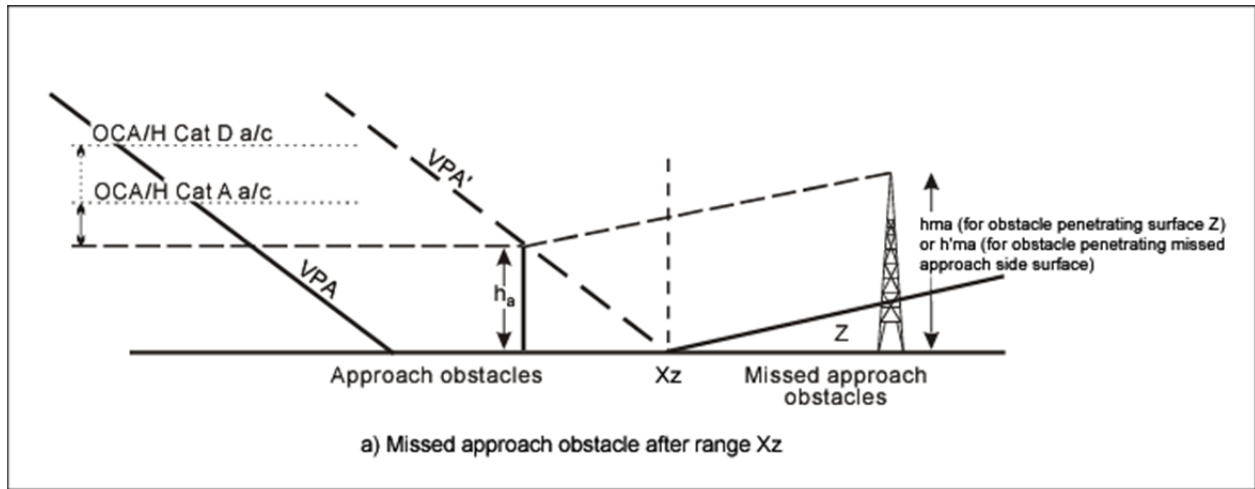

Figure III-3-4-5 a) and b). Missed approach obstacles

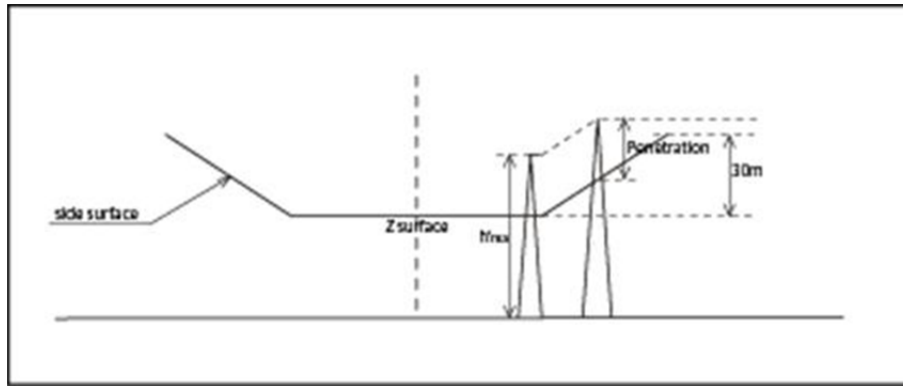

Figure III-3-4-6. Missed approach side surface penetration

End of new text.

...

Appendix A to Chapter 4 TEMPERATURE CORRECTION

...

1.3 Calculation of corrections

Editorial note.— Replace paragraph 1.3.1 and Table III-3-4-App A-1 by the following new text and tables.

1.3.1 To calculate the temperature correction (Δh) to determine the FAS angle and effective VPA apply the following formula:

$$\Delta h = (-\Delta T_{\text{STD}}/L_o)\ln[1+L_o h_{\text{FAP}}/(T_o+L_o h_{\text{THR}})]$$

Where

ΔT_{STD} = temperature deviation from the standard day (ISA) temperature

L_o = standard temperature lapse rate with pressure altitude in the first layer (sea level to tropopause) of the ISA (0.00198°C/ft)

h_{FAP} = procedure height above the threshold at the FAP

T_o = standard temperature at sea level (15°C)

h_{THR} = threshold elevation above mean sea level

Note.— The formula to calculate the temperature correction is based on Equation 24 from Engineering Science Data Unit Publication, Performance Volume 2, Item Number 770221, which assumes an off-Standard atmosphere. For verification purposes, the Tables III-3-4-app Aa-1 to Ab-3 can be used.

...

Table III 3-4 App A-1. Temperature correction to be used in calculating the FAS angle (m)

— *Note.* — T = aerodrome temperature ($^{\circ}\text{C}$) and H = height of FAP above threshold (m).

$T^{\circ}\text{C}/H$	300	450	600	750	900	1-200	1-300	1-400	1-500
0	17	25	33	42	50	67	73	78	84
-10	29	43	58	72	87	116	126	136	146
-20	42	63	84	105	126	169	183	198	212
-30	56	84	112	141	169	226	246	265	285
-40	77	107	143	179	216	289	314	339	364
-50	88	132	176	222	267	358	388	419	450

Table III 3-4 App A-2. Temperature correction to be used in calculating the FAS angle (ft)

— *Note.* — T = aerodrome temperature ($^{\circ}\text{C}$) and H = height of FAP above threshold (ft).

$T^{\circ}\text{C}/H$	1-000	1-500	2-000	2-500	3-000	3-500	4-000	4-500	5-000
0	55	83	111	139	167	195	223	251	280
-10	96	144	192	240	289	337	387	436	485
-20	139	201	279	350	421	492	563	635	708
-30	186	280	374	469	564	659	755	852	949
-40	237	357	477	580	719	842	965	1-088	1-212
-50	293	441	590	739	890	1-041	1-193	1-347	1-500

**Table III-3-4-App Aa-1 Temperature correction to be used
in calculating the FAS angle and effective VPA (ft) (Non-SI)**

<i>Aerodrome temperature (°C)</i>	<i>Height of FAP Above Threshold at Sea Level (ft)</i>								
	1000	1500	2000	2500	3000	3500	4000	4500	5000
50	109	163	218	273	328	383	439	494	550
40	80	120	161	201	242	283	324	365	406
30	50	75	100	125	150	175	201	226	252
20	17	26	34	43	52	60	69	78	87
10	-18	-27	-36	-45	-54	-63	-72	-81	-90
0	-55	-83	-111	-139	-167	-195	-223	-251	-280
-10	-95	-143	-192	-240	-288	-337	-386	-435	-484
-20	-139	-209	-279	-349	-420	-491	-562	-634	-706
-30	-186	-279	-373	-468	-562	-658	-753	-849	-945
-40	-237	-356	-476	-596	-717	-839	-961	-1083	-1206
-50	-293	-440	-588	-737	-886	-1036	-1187	-1338	-1490

**Table III-3-4-App Aa-2 Temperature correction to be used
in calculating the FAS angle and effective VPA (ft) (Non-SI)**

<i>Aerodrome temperature (°C)</i>	<i>Height of FAP Above Threshold at 3000ft AMSL (ft)</i>								
	1000	1500	2000	2500	3000	3500	4000	4500	5000
50	126	189	253	316	380	444	509	573	638
40	98	148	197	247	297	347	397	447	497
30	69	103	138	172	207	242	277	313	348
20	37	56	74	93	112	131	150	169	188
10	3	5	7	8	10	12	13	15	17
0	-33	-50	-66	-83	-100	-116	-133	-150	-167
-10	-72	-108	-144	-181	-217	-254	-291	-328	-365
-20	-114	-171	-229	-287	-345	-403	-461	-520	-579
-30	-159	-240	-320	-401	-482	-564	-646	-728	-810
-40	-209	-314	-419	-525	-632	-739	-846	-954	-1062
-50	-263	-395	-527	-661	-795	-929	-1064	-1200	-1336

**Table III-3-4-App Aa-3 Temperature correction to be used
in calculating the FAS angle and effective VPA (ft) (Non-SI)**

<i>Aerodrome temperature (°C)</i>	<i>Height of FAP Above Threshold at 6000ft AMSL(ft)</i>								
	1000	1500	2000	2500	3000	3500	4000	4500	5000
50	143	215	287	359	431	504	577	650	723
40	116	174	233	291	350	409	468	528	587
30	87	131	175	219	264	308	353	397	442
20	57	85	114	142	171	200	229	258	287
10	24	36	48	60	72	84	97	109	121
0	-11	-17	-23	-28	-34	-40	-45	-51	-57
-10	-49	-74	-98	-123	-148	-173	-198	-223	-248
-20	-90	-135	-180	-225	-271	-317	-363	-409	-455
-30	-134	-201	-268	-336	-404	-472	-541	-610	-679
-40	-181	-272	-364	-456	-548	-641	-734	-828	-921
-50	-233	-350	-468	-586	-705	-825	-944	-1065	-1186

**Table III-3-4-App Ab-1 Temperature correction to be used
in calculating the FAS angle and effective VPA (m) (SI)**

<i>Aerodrome temperature (°C)</i>	<i>Height of FAP Above Threshold at Sea Level (m)</i>								
	300	450	600	750	900	1050	1200	1350	1500
50	33	49	65	82	98	115	132	148	165
40	24	36	48	60	73	85	97	109	122
30	15	22	30	37	45	53	60	68	75
20	5	8	10	13	16	18	21	23	26
10	-5	-8	-11	-13	-16	-19	-21	-24	-27
0	-17	-25	-33	-42	-50	-58	-67	-75	-84
-10	-29	-43	-57	-72	-87	-101	-116	-131	-145
-20	-42	-63	-84	-105	-126	-147	-169	-190	-212
-30	-56	-84	-112	-140	-169	-197	-226	-255	-283
-40	-71	-107	-143	-179	-215	-252	-288	-325	-362
-50	-88	-132	-176	-221	-266	-311	-356	-401	-447

**Table III-3-4-App Ab-2 Temperature correction to be used
in calculating the FAS angle and effective VPA (m) (SI)**

<i>Aerodrome temperature (°C)</i>	<i>Height of FAP Above Threshold at 900m (3000ft) AMSL (m)</i>								
	300	450	600	750	900	1050	1200	1350	1500
50	38	57	76	95	114	133	152	172	191
40	29	44	59	74	89	104	119	134	149
30	21	31	41	52	62	72	83	93	104
20	11	17	22	28	33	39	45	50	56
10	1	1	2	2	3	3	4	4	5
0	-10	-15	-20	-25	-30	-35	-40	-45	-51
-10	-22	-33	-44	-55	-66	-77	-88	-99	-110
-20	-34	-52	-69	-86	-104	-121	-139	-156	-174
-30	-48	-72	-96	-121	-145	-170	-194	-219	-244
-40	-63	-94	-126	-158	-190	-222	-254	-287	-319
-50	-79	-119	-158	-199	-239	-279	-320	-360	-401

**Table III-3-4-App Ab-3 Temperature correction to be used
in calculating the FAS angle and effective VPA (m) (SI)**

<i>Aerodrome temperature (°C)</i>	<i>Height of FAP Above Threshold at 1800m (6000ft) AMSL (m)</i>								
	300	450	600	750	900	1050	1200	1350	1500
50	43	64	86	107	129	151	172	194	216
40	35	52	69	87	105	122	140	158	175
30	26	39	52	65	79	92	105	118	132
20	17	25	34	42	51	59	68	77	85
10	7	10	14	18	21	25	28	32	35
0	-4	-5	-7	-9	-11	-13	-14	-16	-18
-10	-15	-22	-30	-37	-45	-53	-60	-68	-76
-20	-27	-41	-54	-68	-82	-96	-110	-124	-138
-30	-40	-61	-81	-101	-122	-142	-163	-184	-205
-40	-55	-82	-110	-137	-165	-193	-221	-249	-278
-50	-70	-105	-141	-177	-212	-248	-284	-321	-357

End of new text

<i>Origin: IFPP / Secretariat</i>	<i>Rationale</i> Following the publication of the Baro-vertical navigation (Baro-VNAV) attachment in the PBN Manual and the operational experience gained since the first release of the Baro-VNAV criteria in the PANS-OPS, these criteria have been reviewed and made consistent with the PBN Manual as well as other vertically guided approaches like approach procedure with vertical guidance (APV), satellite-based augmentation system (SBAS) and instrument landing system (ILS). This will result in less complex design requirements and less conservative minima which will benefit the implementation of APV procedures. It also addresses an inconsistency in the criteria for aerodromes above 5 000 ft.
---------------------------------------	--

PBN — SBAS/GBAS

Part III

...

Section 2
GENERAL CRITERIA

...

Chapter 6
APPLICATION OF FAS DATA BLOCK FOR SBAS AND GBAS

...

Appendix A to Chapter 6
FAS DATA BLOCK DESCRIPTION FOR SBAS

...

3. EXPLANATION OF FAS DATA BLOCK DATA FIELD ENTRIES

...

- d) *Runway.* Runways are identified by two characters “RW” followed by the runway number. The fifth character is used where needed to indicate a left (L), right (R), or centre (C).

Examples: RW26R, RW 08L, RW18C, RW02

For SBAS circling only procedures the runway number field shall be encoded as the procedure final approach course rounded to the closest 10° and truncated to two characters.

Note:

1. *The runway number valid range is 01 to 36.*
2. *For final approach courses from 355 degrees to 004 degrees, the truncated closest 10 degree expression is “36”.*

...

- f) *Route indicator.* A single alpha character (Z to A or blank, omitting I and O) used to differentiate between multiple final approach segments approaches to the same runway or heliport.

The route indicator coding shall match the duplicate procedure indicator used in the chart identification. The first approach to a runway is labelled “Z”. procedure to a runway end shall be coded as “Z”, except when there is only a single procedure to the runway end. In this case, the field is coded as a blank. Additional alpha characters are incrementally assigned.

If multiple procedures to the same runway end differ only in the missed approach segments, the only difference in the coding of the FAS data blocks, is the coding of the route indicator field so that it matches the duplicate procedure indicators used in the procedure titles.

Example: Z = 1st final approach segment procedure
 Y = 2nd final approach segment procedure
 X = 3rd final approach segment procedure

...

h) *Reference path identifier*. A four-character identifier ...

Example: W09A & W09B would define the two unique FAS data blocks to Rwy 09L.
 W09D would be used to define the FAS data block for Rwy 09C.
 W09E & W09F would be used to define the FAS data blocks for Rwy 09R.

For circling only procedures the two digit runway number should be encoded as the procedure final approach course rounded to the nearest 10° and truncated to two characters.

Note 1.— These suffixes do not have to be in any particular order so as to allow procedures to be added at a later time without changing existing FAS data blocks.

Note 2.— For final approach courses from 355 degrees to 004 degrees, the truncated closest 10 degree expression is “36”.

For SBAS, the reference path identifier is charted and is used by the avionics to confirm to the crew that the correct procedure has been selected.

...

q) *Course width at threshold*. The semi-width (in metres) of the lateral course ...

— ~~Note.— For circling approaches or Helicopter procedures the runway number is set to 00, then the course width field is ignored and the course width is 38 m.~~

Example 106.75

...

Section 3 PROCEDURE CONSTRUCTION

...

Chapter 5 ~~APV I/H PROCEDURES~~ — SBAS LP, APV AND CATEGORY I PROCEDURES

5.1 INTRODUCTION

5.1.1 Procedure construction

This chapter describes the SBAS criteria for the NPA, APV and PA Category I procedure segment, which are specific to the performance of SBAS systems. Throughout this Chapter SBAS OAS refers to both SBAS APV OAS and SBAS Category I OAS. The APV or Category I segment includes the final approach, and the initial and the intermediate phases of the missed approach segment. The other phases of flight are generic in character and are presented in Part III, Section 3, Chapter 1 and Chapter 2.

Note .— SBAS Category I may be constructed using the ILS Category I CRM and/or the ILS Category I OAS. GNSS requirements for SBAS category I procedures can be found in Annex 10, Volume I, Attachment D paragraphs 3.3.6 to 3.3.13.

...

5.1.3 Obstacle clearance altitude/height (OCA/H)

The APV-SBAS criteria in this chapter enable an OCA/H to be calculated for each category of aircraft.

The OCA/H ensures clearance of obstacles from the start of the final approach to the end of the intermediate missed approach segment.

Note.— This OCA/H is only one of the factors to be taken into account in determining decision height as defined in Annex 6.

...

5.3 INTERMEDIATE APPROACH SEGMENT

...

5.3.2 *Alignment.* The intermediate approach segment of an APV-SBAS procedure shall be aligned with the final approach segment.

...

5.4 APV OR CATEGORY I SEGMENT

5.4.1 *General.* The APV or Category I segment of an SBAS APV I or APV II or Category I approach procedure shall be aligned with the runway centre line and contain the final approach, the initial and the intermediate missed approach segments.

5.4.2 *Origin.* The APV or Category I segment starts at the final approach point (the intersection of the nominal vertical path and the minimum altitude specified for the preceding segment). For

navigation database coding purposes, the waypoint located at the FAP shall not be considered as a descent fix. The ~~APV-SBAS~~ OAS surfaces extend into the intermediate approach segment but not beyond this segment (see Figure III-3-5-2).

...

5.4.4 *Termination.* The APV or Category I segment terminates at the point where the final phase of the missed approach commences or where the missed approach climb surface Z reaches a semi-width of 1.76 km (0.95 NM) (for helicopters 1.48 km (0.8 NM)), whichever occurs first.

5.4.5 Obstacle clearance of the APV or Category I segment

5.4.5.1 *General.* The method of calculating OCA/H involves a set of obstacle assessment surfaces (SBAS APV OAS or SBAS Category I OAS). If the SBAS ~~APV-OAS~~ are not penetrated, the OCA/H is still defined by the aircraft category margins. However, if the SBAS ~~APV-OAS~~ are penetrated, the aircraft category margin is added to the highest approach obstacle, or the adjusted height of the largest missed approach penetration, whichever is greater. This value becomes the OCA/H.

5.4.5.2 The SBAS ~~APV-OAS~~ dimensions are related to the approach geometry (GARP/THR distance, GP, RDH) and the category of ~~APV-SBAS~~ operation (APV I or, APV II or Category I). The obstacles penetrating the SBAS ~~APV-OAS~~ are divided into two classes, approach obstacles and missed approach obstacles. The height of the highest approach obstacle or the adjusted missed approach surface penetration (see 5.4.5.9.2) is determined and added to an aircraft category related margin to obtain the appropriate OCA/H. Thus, a table of OCA/H values for each aircraft category may be promulgated for ~~APV I or APV II-SBAS~~ operations at the particular aerodrome.

Note.— At this stage, the SBAS APV OAS method is the only one applicable to calculate the OCA/H of the APV segment. A CRM for these operations is currently under development. Use of the ILS Cat I CRM is permitted to calculate the SBAS Category I OCA/H.

5.4.5.3 *Definition of surfaces.* The SBAS APV OAS consists of seven sloping plane surfaces (denoted by letters W, W', X, Y, and Z) disposed symmetrically about the APV segment track and the horizontal plane containing the threshold (see Figure III-3-5-2). The SBAS Category I OAS contains the following sloping surfaces: W, X, Y and Z, which are equal to the ILS Category I OAS surfaces. The geometry of the sloping surfaces is precisely defined by four simple linear equations of the form $z = Ax + By + C$. In these equations x and y are position coordinates and z is the height of the surface at that position. For each surface the constants A, B and C are obtained from the PANS-OPS OAS software (ICAO public website (www.icao.int) under "Publications") for the operational range of GARP/THR distances and GP. Separate sets of constants are provided for APV I and, APV II or Category I. The SBAS Category I OAS uses the ILS Cat I OAS constants. The constants may be modified by the programme to account for the following:

- a) missed approach climb gradient;
- b) dimensions of specific aircraft; and
- c) the height of the RDH above the nominal value.

The APV OAS Y and Z surfaces are laterally limited by a corridor of 1.76 km (0.95 NM) (for helicopters 1.48 km (0.8 NM)) area semi-width (see Figure III-3-5-2).

5.4.5.4 *Frame of reference.* Positions of obstacles are related to a conventional x, y, z coordinate system with its origin at the threshold (see Figure III-3-5-3). The x axis is parallel to the precision segment track, positive x being measured before threshold and negative x being measured after threshold. The y-axis is at right angles to the x-axis. Although shown conventionally in Figure III-3-5-3, in all calculations associated with SBAS APV-OAS geometry, the y coordinate is always counted as positive. All dimensions connected with the SBAS APV-OAS are specified in metres only. The z-axis is vertical, heights above threshold being positive.

5.4.5.5 SBAS APV-OAS constants — specification. For APV I and APV II operations SBAS procedures the constants A, B and C for each sloping surface are obtained from the PANS-OPS OAS software. The PANS-OPS OAS software gives coefficients for GP angles between 2.5 and 3.5 degrees in 0.1-degree steps, and for any GARP-threshold distance between 2 000 m and 4 500 m. For an example of the PANS-OPS OAS software results see Figure III-3-5-4.

5.4.5.6 *Calculation of SBAS APV OAS heights.* To calculate the height z of any of the sloping surfaces at a location x', y', the appropriate constants should be first obtained from the PANS-OPS OAS software. These values are then substituted in the equation $z = Ax' + By' + C$. If it is not apparent which SBAS APV OAS is above the obstacle location, this should be repeated for the other sloping surfaces. The SBAS APV OAS height is the highest of the X, Y, Z plane heights and the height of the lowest W-W' plane heights (zero if all the plane heights are negative). The SBAS Category I OAS heights are calculated in the same way using the ILS Cat I OAS constants.

~~The~~ For APV I or APV II OAS, W and W' planes intersect, and the accountable W-W' plane is always the lower of these two planes, i.e. height of OAS = max [ZX; ZY; ZZ; min ZW; ZW']

Where ZX, ZY, ZZ, ZW and ZW' are the heights of the X, Y, Z, W and W' planes.

Note.— The PANS-OPS software also contains an OCH calculator that will show the height of the SBAS APV or Category I OAS surface Z above any X, Y location. It includes all the adjustments specified for the APV or Category I approach geometry, aircraft dimensions, missed approach climb gradient and RDH.

5.4.5.7 *SBAS APV-OAS template construction.* Templates, or plan views of the SBAS APV-OAS contours to map scale, are sometimes used to assist identification of obstacles for detail survey (see Figure III-3-5-5). The SBAS APV-OAS data in the PANS-OPS software includes the coordinates of the points of intersection of the sloping surfaces at threshold level and at 1.9 km (1.0 NM) laterally from the final approach track (see Figure III-3-5-5). The intersection coordinates at threshold level are labelled as C, D and E.

...

5.4.5.9 *Determination of OCA/H*

5.4.5.9.1 *General.* The OCA/H is determined by accounting for all obstacles which penetrate the SBAS APV-OAS surfaces applicable to the APV-SBAS operation being considered. The surfaces which apply to each APV-SBAS category of operations are:

APV I operation: SBAS APV I OAS.

APV II operation: SBAS APV II OAS.

SBAS Category I operation: ILS Category I OAS.

...

5.4.5.9.3 *Calculation of OCA/H.* After the approach and missed approach obstacles have been identified by one of the above described methods, the OCA/H is determined as follows:

- a) determine the height of the highest approach obstacle;
- b) reduce the heights of all missed approach obstacles to the heights of equivalent approach obstacles by the formula given below; and
- c) determine OCA/H by adding the appropriate Table II-1-1-2, “Height loss altimeter margin” aircraft category related margin to the height of the highest approach obstacle (real or equivalent).

$$h_a = \frac{h_{ma} \cot Z + (X - X_E)}{\cot Z + \cot \theta}$$

where: h_a = height of equivalent approach obstacle
 h_{ma} = height of missed approach obstacle
 θ = VPA
 Z = angle of missed approach surface
 X = range of obstacle relative to threshold (negative after threshold)
 X_E = $900 + (38/\tan \theta)$ for APV I and $X_E = 900 + (8/\tan \theta)$ for APV II
 For Cat H, $X_E = 700 + (38/\tan \theta)$ for APV I and $X_E = 700 + (8/\tan \theta)$ for APV II.

Note.— For SBAS Category I operations, OCA/H calculations may use the ILS Category I OCA/H calculation.

5.4.5.9.4 Adjustment for high airfield elevations and steep glide path angles

...

5.4.5.9.4.2 *Steep glide path angle.* Procedures involving glide paths greater than 3.5° or any angle when the nominal rate of descent (V_{at} for the aircraft type multiplied by the sine of the glide path angle) exceeds 5 m/s (1 000 ft/min) are non-standard for fixed-wing aircraft. They require the following:

- a) increase of height loss margin (which may be aircraft-type specific);
- b) adjustment of the origin of the missed approach surface;
- c) adjustment of the slope of the SBAS APV OAS W and W' surfaces or SBAS Category I OAS adjustment of the W surface;

...

5.5 MISSED APPROACH SEGMENT

5.5.1 General

5.5.1.1 The criteria for the final missed approach are based on those for the general criteria (see Part I, Section 4, Chapter 6) with certain modifications to allow for the different areas and surfaces associated with the APV or Category I segment and the possible variation in OCA/H for that segment with aircraft category.

...

5.5.1.3 Where obstacles identified in the final missed approach segment result in an increase in any of the OCA/H calculated for the APV or Category I segment, a higher gradient of the missed approach surface (Z) may be specified in addition if this will provide clearance over those obstacles at a specified lower OCA/H (see Part I, Section 4, Chapter 6, 6.2.2.2).

5.5.2 Straight missed approach

5.5.2.1 *Termination of the APV or Category I segment.* The APV or Category I segment terminates at the range where the Z surface reaches a semi-width of 1.76 km (0.95 NM) (for helicopters 1.48 km (0.8 NM)). For the straight part of the final missed approach the area semi-width is equal to 1.76 km (0.95 NM) (for helicopters 1.48 km (0.8 NM)). Secondary areas are not applied. (See Figure III-3-5-8).

...

5.5.3 Turning missed approach

5.5.3.1 *General.* For SBAS APV procedures, the missed approach turn shall be prescribed at a designated TP. Turns at a designated altitude/height or “as soon as practicable” cannot be implemented because of the current SBAS receiver capabilities. The criteria used depend on the location of the turn relative to the threshold and the normal termination of the APV or Category I segment and are as follows:

- a) *turn outside APV or Category I segment.* If a turn is prescribed after the normal termination range of the APV or Category I segment, the general criteria of Part I, Section 4, Chapter 6, 6.4.6.4 apply with the following exceptions:
 - 1) OCA/H is replaced by (OCA/HAPV – HL); and
 - 2) because SOC is related to OCA/H, it is not possible to obtain obstacle clearance by the means used in the general criteria by independent adjustment of OCA/H or MAPt.
- b) *turn inside APV or Category I segment.* If a turn is prescribed at a designated TP such that the earliest TP is within the normal termination range, the criteria specified in 5.5.3.2 and 5.5.3.3 below shall be applied.

5.5.3.2 *Turn at a designated TP after the threshold with earliest TP before normal termination of APV or Category I segment.* Where a turn is specified at a designated TP after the threshold, and the earliest TP is before the normal termination range of the APV or Category I segment, the APV or Category I segment is curtailed and terminates at the earliest TP. This allows the calculation of OCA/HAPV and (OCA/HAPV – HL); SOC is then determined.

5.5.3.2.1 *Area*. The turn area is constructed as specified in Part I, Section 4, Chapter 6, 6.4.6, “Turn initiated at a designated turning point”, except that it is based on the width of the SBAS ~~APV~~-OAS Y surface contours at the earliest and latest TP (see Figure III-3-5-10).

...

5.5.3.3.1 *Turning point*. A latest turning point is chosen to allow the aircraft to avoid obstacles straight ahead. Then the turning point (TP) is plotted before the latest TP at a distance equivalent to 0.6 km (0.3 NM) plus 6 seconds of flight (pilot reaction and bank establishing time) at the final missed approach speed (or maximum published missed approach speed) plus 56 km/h (30 kt) tailwind. For this kind of turn the SOC is coincident with the earliest TP and the APV or Category I segment terminates at this point. The OCA/HAPV is equal to the altitude/height of the SOC increased by the HL value.

5.5.3.3.2 *Areas*. The turn area is constructed as specified in Part I, Section 4, Chapter 6, except that it is based on the width of the SBAS ~~APV~~-OAS Y surface contours at the earliest and latest TP (see Figure III-3-5-11).

...

5.6 SIMULTANEOUS ILS/MLS/GBAS/APV SBAS APPROACHES TO PARALLEL OR NEAR-PARALLEL INSTRUMENT RUNWAYS

Note.— *Guidance material is contained in the Manual on Simultaneous Operations on Parallel or Near-Parallel Instrument Runways (SOIR) (Doc 9643).*

5.6.1 General

When it is intended to use an APV or Cat I SBAS approach procedure to parallel runways, simultaneously with ILS, MLS or, GBAS precision or another APV or Cat I SBAS approach procedure, the following additional criteria shall be applied in the design of both procedures:

- a) the maximum intercept angle with the final approach course approach track is 30°. The point of intercepting the final approach track course should be located at least 3.7 km (2.0 NM) prior to the point of intercepting the glide path;
- b) the minimum altitudes of the intermediate segments of the two procedures differ by at least 300 m (1 000 ft); and
- c) the nominal tracks of the two missed approach procedures diverge by at least 30°, the associated missed approach turns being specified as “as soon as practicable” which may involve the construction of (a) missed approach procedure(s).

~~APV SBAS approaches may also be implemented to serve both runways simultaneously; however, a separate safety study needs to be carried out when it is intended to use SBAS for both runways.~~

...

5.7 SBAS APV APPROACH WITH OFFSET FINAL APPROACH TRACK ALIGNMENT

5.7.1 Use of SBAS APV approach with offset alignment

...

5.8 SBAS LP

5.8.1 *Final approach segment.* The final approach segment areas are formed by using the outer lateral boundaries of the X surfaces beginning at threshold and extending until reaching a semi-width of 1 760 m (0.95 NM) and continuing at that semi-width at greater distances. This occurs at approximately 11.7 km (6.3 NM), depending on the distance from LTP to GARP. A secondary area is formed based on a primary width of 880 m (0.475 NM). The secondary area continues at this width toward the threshold until reaching the semi-width of the X surfaces. At this point the secondary area width diminishes to zero.

5.8.1.1 *Final approach segment semi-width surfaces.* The semi-width of the final approach surfaces shall be determined using the following formulae:

$$W/2 = Y_{LTP} = [-0.0031 (LTP - GARP) + 182.83] \text{ metres}$$

$$\theta_x = [-0.0033 (LTP - GARP) + 9.4367] \text{ degrees}$$

Where: $W/2$ is the semi-width of the final approach surface at the LTP.

θ_x is the angle of splay outward from the LTP of the final approach surface (see Figures III-5-12 and III-5-13).

5.8.2 *Intermediate segment.* The intermediate segment is joined to the final segment by constructing a line from the outer boundary of the intermediate segment to the outer boundary of the X surface at 30 degrees to the track and passing through the specified semi-width at the FAF/FAP. See Part III, Section 3, Chapter 4 and Figure III-5-14.

5.8.3 *Missed approach segment.* The missed approach area shall start at the early ATT of the MAPt, with a splay of 15 degrees each side of the outer boundary of the final segment (X surface lateral boundaries). Secondary areas shall be applied when the expanded semi-width reaches the appropriate dimension for the RNP or RNAV navigation accuracies applied for missed approach guidance. The obstacle evaluations and establishment of the OCA/H shall be carried out in the same manner as the LNAV criteria.

Editorial note.— Re-number subsequent paragraphs accordingly.

5.8.5.9 PROMULGATION

~~5.8.1~~5.9.1 The general criteria in Part I, Section 4, Chapter 9, 9.5, “Procedure naming for arrival and approach charts” apply. The instrument approach chart for an SBAS approach procedure shall be identified by the title RNAV (GNSS) Rwy XX. ~~If more than one GNSS approach is published for the same runway, the Duplicate Procedure Title convention shall be applied, with the approach having the lowest minima being identified as RNAV(GNSS) Z Rwy XX.~~ (For further details, see Section 5, Chapter 1.)

5.8.2 Promulgation of OCA/H values

~~5.8.2.1~~5.9.2 *Promulgation of OCA/H for SBAS APV approach procedures.* The OCA/H values shall be promulgated for those categories of aircraft for which the procedure is designed. The values shall be based on the following standard conditions:

- a) ~~LPV~~ approach flown with pressure altimeter;
- b) standard aircraft dimensions (see 6.1.3); and
- c) 2.5 per cent missed approach climb gradient.

Additional values of OCA/H may be agreed between operators and appropriate authority and promulgated, on the basis of evidence supporting the modifications defined in 5.4.5.7.

~~5.8.3~~5.9.3 *Minima box.* A table of OCA/H values for each aircraft category may be promulgated for SBAS operations at the particular aerodrome. All APV and Cat I SBAS OCA/H's are promulgated as LPV lines of minima. All LP OCA/Hs shall be promulgated as LP lines of minima.

~~5.8.4~~5.9.4 *Additional gradient for the final missed approach segment.* If obstacles identified in the final missed approach segment result in an increase in any of the OCA/H calculated for the precision segment, an additional steeper gradient may also be specified for the gradient of the missed approach surface (Z) for the purpose of lowering the OCA/H (see Part I, Section 4, Chapter 6, 6.2, “Climb gradient and MOC”).

Note.— For further requirements in PBN charting, see Part III, Section 5, Chapter 1.

5.9.5 *Final approach segment data block (FAS DB).* The FAS DB is specified in Part III, Section 5, Chapter 2. It shall be promulgated in a textual format on the verso of the approach chart as shown in Table III-3-5-12.

Data Content	Example Data
Operation Type	0
SBAS Provider Identifier	1
Airport Identifier	LFLC
Runway Number	26
Runway Letter	
Approach Performance Designator	0
Route Indicator	Z
Reference Path Data Selector	0
Reference Path Identifier	E26A
LTP/FTP Latitude	454718.3185N
LTP/FTP Longitude	0031114.4545E
LTP/FTP Height above ellipsoid	372.3
FPAP Latitude	454705.1260N
FPAP Longitude	0030900.4790E
Approach Threshold Crossing Height (TCH)	15
Approach TCH Units Selector	1
Glidepath Angle (GPA)	3
Course Width at threshold	105
Length Offset	48
Horizontal Alert Limit (HAL)	40
Vertical Alert Limit (VAL)	50
Final Approach Segment CRC	AB8761C6

Table III-3-5-12. Example of textual description of data required for the final approach segment data block

5.9.6 *SBAS FAS DB Information to be promulgated.* The following information shall be promulgated for SBAS APV procedures:

- a) *Channel number.* A globally unique channel number in the range 40,000 to 99,999.
- b) *Reference path identifier (RPI).* The RPI as defined in Part III, Section 2, Chapter 6, Appendix B, paragraph 2.5 with the procedure information. This is required for charting and data base encoding.
- c) *SBAS service provider.* Since for SBAS vertically guided procedures information from different SBAS cannot be mixed, the leading alpha character in the Reference Path Identifier (RPI) field may be used to identify the service provider.

Examples:

W17A for WAAS
E22A for EGNOS.

d) *FPAP and LTP orthometric height.* The “orthometric height” field is the height of a surveyed point in reference to mean sea level (MSL). It shall be included with the procedure data and expressed in meters with a resolution of a tenth a meter.

...

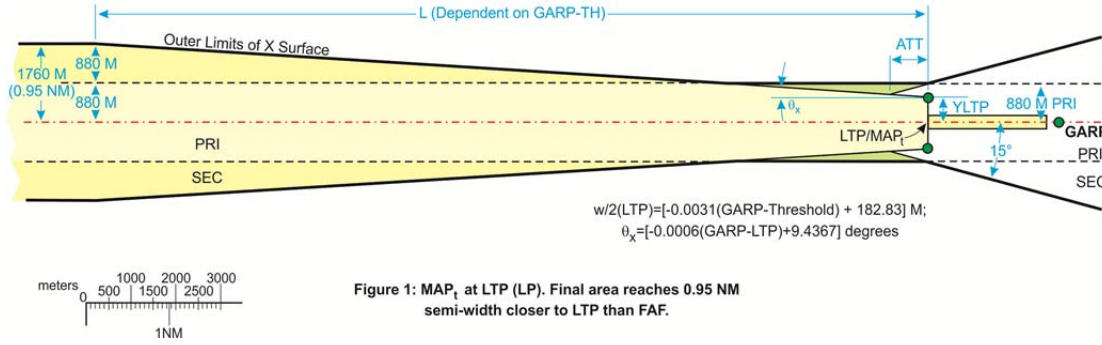

Figure III-3-5-12. MAP_t at LTP (LP)

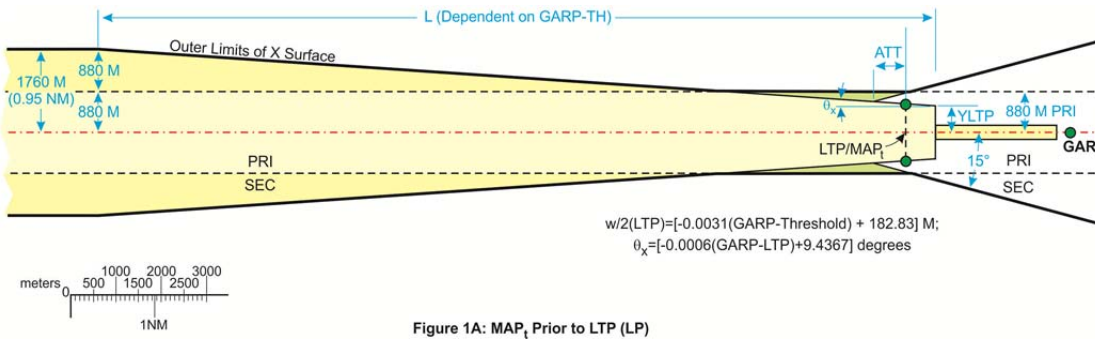

Figure III-3-5-13. MAP_t prior to LTP

...

6.8.7 Reference path identifier

Reference path identifier (RPI). The RPI, as defined in Part III, Section 2, Chapter 6, Appendix B, paragraph 2.5, shall be promulgated with the procedure information.

6.8.8 Channel number

GBAS channel number. The channel number for the procedure as defined in Annex 10, Volume I, Attachment D, paragraph 7.7, shall be promulgated with the procedure information.

6.8.9 GBAS reference point detail

GBAS reference point information. The following information about the GBAS reference point shall be promulgated with the procedure information: latitude/longitude of the centroid of the GBAS reference receivers, identifier, service volume radius, MSL elevation, and ellipsoid height.

...

Section 5

PUBLICATION

...

Chapter 2

AERONAUTICAL DATABASE PUBLICATION REQUIREMENTS

...

2.3 For RNAV instrument approach procedures, the following data shall be published in tabular form or a formal textual description on the verso of the chart or a separate, properly referenced sheet (see Annex 4, 11.10.9):

...

c) unambiguous description of the path, including, in the case of SBAS APV procedures, a textual representation of the FAS Data Block (as described in Appendix A to Part III, Section 2, Chapter 6; Appendix to Part IV, Chapter 3 and illustrated in Figure III-3-5-12), and the method of termination of each specified segment;

...

Attachment to Part III

DERIVATION OF THE SBAS OBSTACLE ASSESSMENT SURFACES (OAS)

1. ASSUMPTIONS

The methodology behind the derivation of the SBAS OAS is based on the following assumptions:

- a) the signal-in-space performances meet the Annex 10, Volume I, requirements;
- b) the GNSS avionics meet the requirements of ~~RTCA DO-229C~~ RTCA DO-229D, Minimum Operational Performance Standards (MOPS) for Global Positioning System/Wide Area Augmentation System Airborne Equipment or an equivalent IFR certification standard;
- c) angular display generates lateral and vertical flight technical errors (FTE) comparable to the ILS values;
- d) the lateral and vertical FTE are independent;
- e) the observed SBAS correlation coefficients are the same as the ILS correlation coefficients;
- f) in the case of continuity failure the reversion mode for APV ~~operations~~ and Category I procedures is the approach mode (LNAV);
- g) ~~during~~ for APV and LP procedures with a straight missed approach coded as a TF segment the system ~~remains in~~ changes to LNAV final approach mode (LNAV) up to the turn initiation point of the first waypoint of the missed approach procedure; and
- h) the decision altitude/height (DA/DH) is read from a baro-altimeter.

Note.— The first waypoint of the missed approach is the waypoint after the landing threshold point (LTP).

2. SBAS APV OBSTACLE ASSESSMENT SURFACES

The criteria are based on two sets of obstacle assessment surfaces:

- a) final approach surfaces; and
- b) missed approach surfaces.

2.1 Final approach surfaces

2.1.1 Runway centre line surfaces

2.1.1.1 Along the runway centre line two surfaces are identified (W' and W). The W' surface is defined, close to the runway threshold, by applying a value, equal to the vertical full scale deflection, defined in ~~DO-229C~~ DO-229D (paragraph 2, 2.4.4.4), plus the VAL, under the nominal ~~VPA~~ GPA. Further from the threshold, the W' surface rises above the W surface, which then replaces it.

2.1.1.2 The way-point located at the FAP for navigation database coding purposes is not considered as a descent fix and the APV OAS extend into the intermediate segment.

2.1.2 Lateral surfaces

2.1.2.1 The X surface is derived from the X ILS surface which is lowered by a value equal to the difference between the VAL associated to the corresponding APV approach and 12 metres. This assumes that:

- a) the lateral and vertical FTE values are independent and are the same as ILS;
- b) the lateral NSE is the same as ILS;
- c) the ~~core performance~~ vertical NSE of the APV operation is ~~not~~ greater than the ILS; and
- d) SBAS APV NSE correlation coefficients are consistently small and of the same magnitude as observed ILS correlation coefficients.

2.1.2.2 As Annex 10 horizontal performance requirements for APV are equivalent to Category I ILS localizer performance requirements, the X surface is limited laterally by the line DD'' from the ILS/LOC.

2.2 Missed approach surfaces

2.2.1 Runway centre line surface

A missed approach surface, comparable to the ILS Z surface, is identified along the runway centre line. This surface should protect an aircraft flying above the vertical nominal path during the final approach segment, assuming the DA/H is read from a baro-altimeter. For this purpose it is necessary to move the origin of the APV Z surface away from the threshold by a distance greater than the 900 metre value of the ILS criteria. This 900 metre value is increased by the difference between the VAL associated to the corresponding APV approach and 12 metres divided by the tangent of the final ~~vertical~~ glide path angle.

$$\frac{(VAL - 12)}{\tan VPA \tan GPA}$$

2.2.2 Lateral surfaces

2.2.2.1 ~~The system remains in NPA~~ When the initial missed approach segment is coded as a TF segment and aligned within 3° of the final approach course, the system maintains LNAV final approach mode until the first turning point. As a result, the final missed approach is protected by a corridor with an area semi-width of 1.76 km (0.95 NM) (Cat H 1.48 km (0.8 NM)).

2.2.2.2 The missed approach criteria accommodates:

- a) aircraft initiating a missed approach above the OCH; and
- b) continuity failure of the APV level of service during the final approach.

2.2.2.3 A linking surface, comparable to the ILS Y surface, is created between the final approach X surface and the missed approach Z surface. This Y surface, defined by the limit of the X surface, assumes a climb gradient of 2.5% and a splay of 20%. It is limited laterally by the 1.76 km (0.95 NM) (Cat H 1.48 km (0.8 NM)) area semi-width associated with the missed approach guidance.

2.2.3.4 SBAS Category I precision approach procedure obstacle clearance surfaces are discussed in Volume II, Part III, Section 3, Chapter 5.

Note 1.— High quality track guidance throughout the final approach segment, coupled with continued lateral guidance throughout the straight missed approach justifies the use of a 20% splay for the Y surface. This splay does not have to be modified to ensure compatibility between categories of operation as for ILS (see Attachment to Part II).

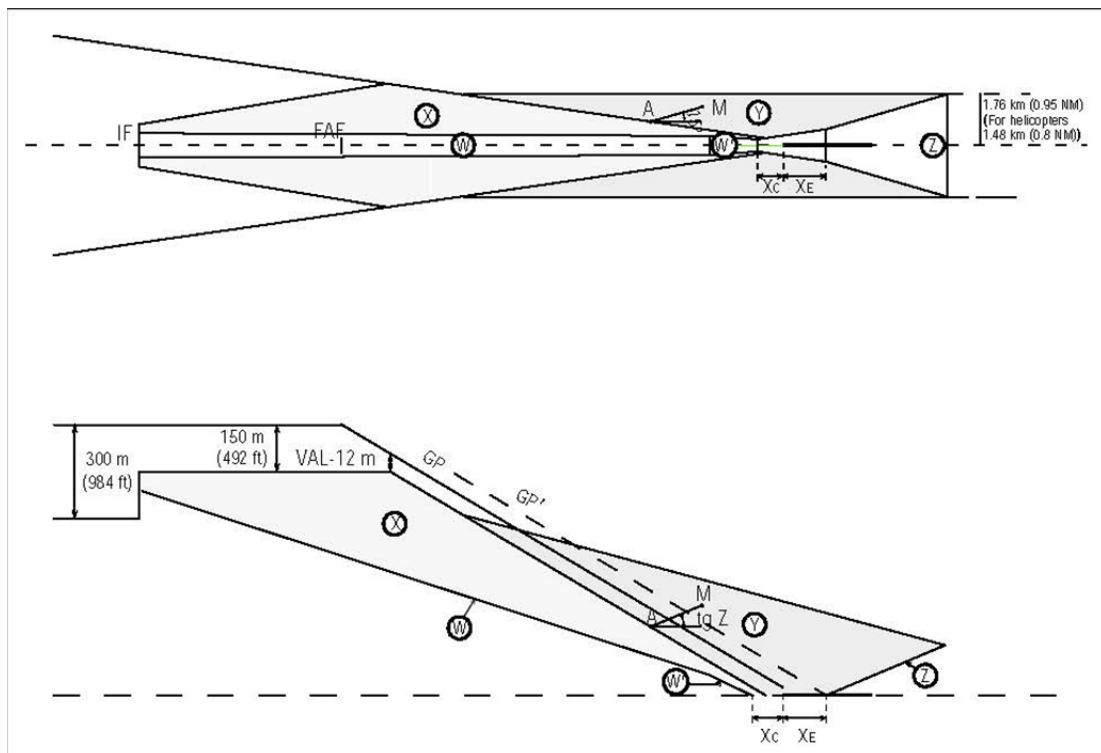

Figure III-Att-1. Illustration of SBAS APV obstacle assessment surfaces

<p><i>Origin:</i> <i>IFPP / Secretariat</i></p>	<p><i>Rationale</i></p> <p>This clarifies the method by which the final approach segment data for SBAS and GBAS instrument approach procedures is published in order to meet the minimum requirements for aeronautical charts and databases. This will ensure that flight crew are able to correctly identify and select the correct procedures.</p> <p>Amendment 85 to ICAO Annex 10 introduced the SBAS signal in space performance requirements for Cat I precision approach operations. PANS-OPS has to be updated to reflect these improved performance requirements. Cat I SBAS approach operations will provide improved accessibility through lower minima.</p> <p>The route indicator (RI) field in the SBAS FAS data block encoding provides the same information as the ARINC Characteristic 424 Supplement 19 Multiple Approach Indicator which is synonymous with the Duplicate Procedure Indicator terminology already used in Doc 8168. This amendment standardises the use of this indicator and, hence improves safety.</p> <p>This amendment also corrects the current information provided on encoding FAS data block.</p>
---	---

CDO/CCO

**Part I
GENERAL**

...

**Section 1
DEFINITIONS, ABBREVIATIONS AND ACRONYMS
AND UNITS OF MEASUREMENT**

**Chapter 1
DEFINITIONS**

...

Continuous climb operation (CCO). An operation, enabled by airspace design, procedure design and ATC, in which a departing aircraft climbs continuously, to the greatest possible extent, by employing optimum climb engine thrust and climb speeds until reaching the cruise flight level.

Continuous descent operation (CDO). An operation, enabled by airspace design, procedure design and ATC, in which an arriving aircraft descends continuously, to the greatest possible extent, by employing minimum engine thrust, ideally in a low drag configuration, prior to the final approach fix /final approach point.

...

**Chapter 2
ABBREVIATIONS AND ACRONYMS**

...

ATM Air traffic management
CCO Continuous climb operation
CDO Continuous descent operation

...

**Section 3
DEPARTURE PROCEDURES**

...

**Chapter 2
GENERAL CONCEPTS FOR DEPARTURE PROCEDURES**

...

2.2 DESIGN PRINCIPLES

2.2.1 Departures may be designed as straight departures or turning departures (see Chapter 3). Procedure design should consider the environmental and efficiency advantages afforded by implementation of a continuous climb operation (CCO).

Note.— The *Continuous Climb Operations (CCO) Manual* (Doc 9993) provides guidance on implementing CCO and balancing CCO within the context of other ATM operations.

...

Section 4 ARRIVAL AND APPROACH PROCEDURES

...

Chapter 2 ARRIVAL SEGMENT

...

2.1 STANDARD INSTRUMENT ARRIVALS

2.1.1 General

...

2.1.1.8 Procedure design should consider the environmental and efficiency advantages afforded by implementation of a continuous descent operation (CDO). Airspeed and altitude/level restrictions, if any, should be included. These should take into account the operational capabilities of the aircraft category involved, in consultation with the operators.

Note.— The *Continuous Descent Operations (CDO) Manual* (Doc 9931) provides guidance on implementing CDO and balancing CDO within the context of other ATM operations.

...

Chapter 4 INTERMEDIATE APPROACH SEGMENT

...

4.3 INTERMEDIATE APPROACH SEGMENT BASED ON A STRAIGHT TRACK ALIGNMENT

...

4.3.3 Procedure altitude/height and descent gradient

...

4.3.3.2 If a descent is necessary the maximum permissible gradient will be 5.2 per cent (Cat H, 10 per cent) or, if the intermediate approach speed is restricted to 165 km/h IAS (90 kt IAS), 13.2 per cent. In this case, a horizontal segment with a minimum length of 2.8 km (1.5 NM) should be provided prior to the final approach for Cat C and D aircraft. For procedures specific to Cat A and B aircraft, this minimum length may be reduced to 1.9 km (1.0 NM). This should allow sufficient distance for aircraft to decelerate and carry out any configuration changes necessary before final approach segment.

Note.— Referring to 4.3.3.1 and 4.3.3.2, to fly an efficient descent profile the pilot may elect to configure whilst in a continuous descent along this segment.

<i>Origin:</i> <i>IFPP / Secretariat</i>	<i>Rationale</i> CDO and CCO provide significant fuel efficiency and environmental benefits. Recently, new manuals have been published that provide guidance on how to implement CDO and CCO as an integral part of an airspace concept. The PANS-OPS is currently not very clear on permitting the use of a continuous vertical glide path in the intermediate segment and could therefore be counterproductive in supporting the implementation of CDO/CCO's. This proposed amendment addresses the issue and updates the PANS-OPS.
---	--

REGULATORY REQUIREMENTS

**Part I
GENERAL**

...

**Section 2
GENERAL PRINCIPLES**

...

**Chapter 4
QUALITY ASSURANCE**

4.1 GENERAL

...

4.1.5 The safety of air navigation is highly dependent on the quality of aeronautical data. Processes for data quality assurance, from data origination through to publication in the States Aeronautical Information Publication (AIP), is detailed in ~~the *Instrument Flight Procedure Quality Assurance Manual*~~ the *Quality Assurance Manual for Flight Procedure Design* (Doc 9906).

...

4.6 GROUND AND FLIGHT VALIDATION

4.6.1 Validation

Validation is the necessary final quality assurance step in the procedure design process, prior to publication. The purpose of validation is the verification of all obstacle and navigation data, and assessment of flyability of the procedure. Validation normally consists of ground validation and flight validation. Ground validation shall always be undertaken. When the State can verify, by ground validation, the accuracy and completeness of all obstacle and navigation data considered in the procedure design, and any other factors normally considered in the flight validation (4.6.3), then the flight validation requirement may be dispensed with. The process for the validation of flight procedures is detailed in the *Quality Assurance Manual for Flight Procedure Design, Volume 5 — Validation of Instrument Flight Procedures* (Doc 9906).

...

4.6.7 Additional detailed information and guidance concerning flight inspection ~~and validation of instrument flight procedures~~, as well as qualifications and certification of flight inspectors, can be found in the ICAO *Manual on Testing of Radio Navigation Aids*, Volumes I, II, and III (Doc 8071).

...

4.8 PROCEDURE DESIGN AUTOMATION

...

4.8.4 As States are responsible for the safety of instrument flight procedures, they should ensure that the software packages used in the design of procedures have been validated. The ~~*Procedure Design Software Validation Manual (to be developed)*~~, *Quality Assurance Manual for Flight Procedure Design*, Volume 3 — *Flight Procedure Design Software Validation* (Doc 9906) provides guidance to assist States in this task.

...

<p><i>Origin:</i> <i>IFPP / Secretariat</i></p>	<p><i>Rationale</i></p> <p>Currently, there are no ICAO provisions at the Annex (SARPs) level, governing the responsibility of Contracting States for the provision of an instrument flight procedure design service. As a result, implementation of flight procedure design provision and oversight varies in scope, method and quality across the world. This amendment provides a clear statement of State responsibilities leading to improved standards and flight safety. It also updates the PANS-OPS to refer to new volumes of the <i>Quality Assurance Manual for Flight Procedure Design</i> (Doc 9906).</p> <p>These amendments are consequential to Annex 11.</p>
---	--

FRAME OF REFERENCE

**Part I
GENERAL**

...

**Section 1
DEFINITIONS, ABBREVIATIONS AND ACRONYMS
AND UNITS OF MEASUREMENT**

...

**Chapter 4
FRAME OF REFERENCE**

4.1 Annex 4 — *Aeronautical Charts*, Annex 11 — *Air Traffic Services* and Annex 15 — *Aeronautical Information Services* require that WGS 84 is used as the horizontal (geodetic) reference system for international air navigation. The publication of waypoints and routes and the survey of terrain and obstacle data in WGS 84 does not mean that all airspace and procedure design calculations must be ellipsoidal. Historically, Annex 14 and PANS-OPS, Volume II obstacle limitation and clearance areas have been defined using planar methods and these methods continue to be acceptable. The essential requirement is that the waypoints are correctly converted to and from WGS 84, as specified in Annexes 4, 11, 14 and 15. See also *The Quality Assurance Manual for Flight Procedure Design* (Doc 9906), Volume III — *Software Validation*.

Note.— It is not considered necessary to revise all procedures that were calculated manually. Furthermore, the simple methods remain valid as checks against major blunder errors.

4.2 Co-ordinates generated by software tools will not be exactly the same as co-ordinates generated manually when the former uses ellipsoidal formulae and the latter uses planar formulae. Such differences are acceptable provided that they are less than the accuracy requirements detailed in the Aeronautical Data Quality Requirements of the Annexes to the Convention on International Civil Aviation.

Note.— Co-ordinates generated by different software tools may not be exactly the same if the different software packages use different assumptions, apply rounding at different times or calculate different interim values.

...

<i>Origin:</i> <i>IFPP / Secretariat</i>	<i>Rationale</i> With the introduction of the ICAO requirement to use WGS-84 as the ICAO position data standard there has been confusion as to which mathematical methodology should be used by procedure developers to measure obstacle clearance areas and evaluate obstacles in procedure development. This amendment: <ol style="list-style-type: none">1. clarifies the requirements for the calculation of obstacle clearance areas and surfaces;2. avoids costs of ellipsoidal calculation software and related training where this is not essential; and3. simplifies the validation of instrument procedures.
---	--

PANS-OPS ANNEX 14 ALIGNMENT

**Part I
GENERAL**

...

**Section 4
ARRIVAL AND APPROACH PROCEDURES**

...

**Chapter 5
FINAL APPROACH SEGMENT**

...

5.4 OBSTACLE CLEARANCE ALTITUDE/HEIGHT (OCA/H)

...

5.4.6 Protection for the visual segment of the approach procedure

5.4.6.1 All new straight-in instrument approach procedures ...:

...

b) for all other straight-in instrument approach procedures:

- 1) a base width of 300 m (150 m either side of the extended runway centre line) for a Code 3 and 4 runway and 150 m (75 m either side of the extended runway centre line) for Code 1 and 2, equal to the runway strip width originating 60 m prior to the runway threshold, splaying 15 per cent on either side of the extended runway centre line, and terminating at the point where the height of the surface reaches the OCH (see Figure I-4-5-7-b));

Editorial note.— Amend Figure I-4-5-7-b) as follows:

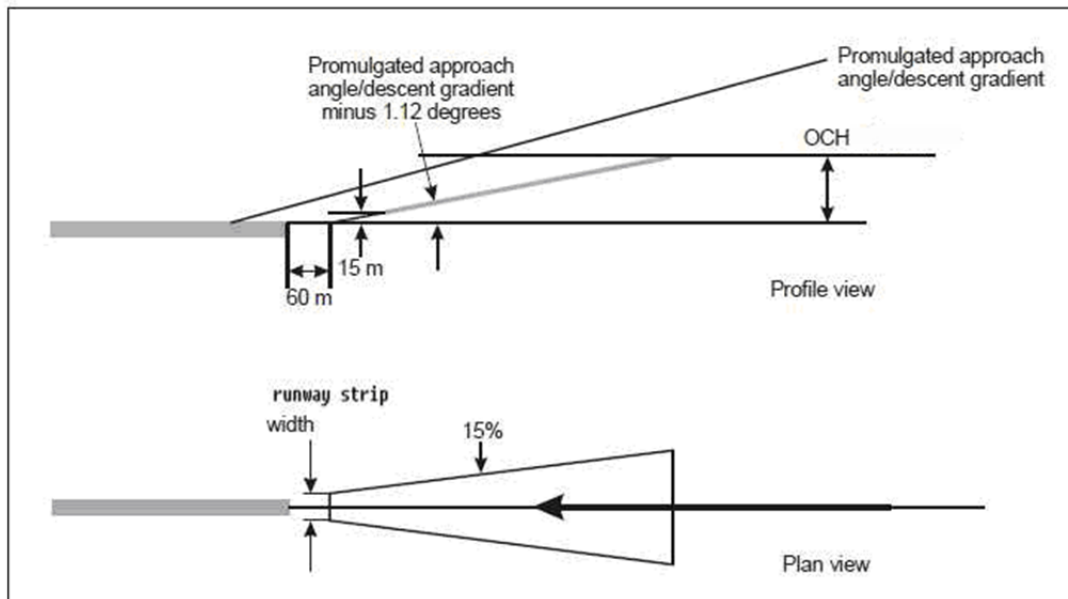

Figure I-4-5-7-b). Visual segment surface other approach procedures normal straight-in approach

...

<p><i>Origin:</i> IFPP / Secretariat</p>	<p><i>Rationale</i></p> <p>The approach OLS (Annex 14) and the VSS (PANS-OPS) are intended to protect aircraft on final approach and the runway strip provides protection once on the ground. It follows that congruence between the runway strip and the VSS is of prime importance. In order to match the VSS to the runway strip, the PANS-OPS criteria should be defined in such a way that they are not more constraining than Annex 14 recommendations. This amendment will allow a faster and more widespread implementation of VSS and is introduced to accelerate the introduction of APV approaches and to improve safety.</p>
--	--

HELICOPTERS

Part I GENERAL

Section 1 DEFINITIONS, ABBREVIATIONS AND ACRONYMS AND UNITS OF MEASUREMENT

Chapter 1 DEFINITIONS

...

Descent point (DP). A point defined by track and distance from the MAPt to identify the point at which the helicopter may descend below the OCA/H on a visual descent to the heliport/landing location.

...

Direct visual segment (Direct-VS). ~~The portion of flight that connects the PinS to the landing location; this can be either direct to the landing location or via a descent point (DP) where a limited track change may occur.~~ A visual segment designed as:

- a leg, which may contain a single turn, from the MAPt direct to the heliport or landing location or via a descent point to the heliport or landing location, in a PinS approach;
- a straight leg from the heliport or landing location to the IDF in a PinS departure.

...

Fictitious heliport point (FHP). The FHP is a point over which the PinS final approach segment path passes at a relative height defined as the Fictitious Heliport Point Crossing Height (FHPCH). It is defined by the WGS-84 latitude, longitude and ellipsoid height. The FHP replaces the FTP for PinS approaches. The FHP elevation is the same as the actual landing heliport elevation.

...

Height above surface (HAS). The difference in height between the OCA and the elevation of the highest terrain, water surface or obstacle within a radius of at least 1.5 km (0.8 NM) from the MAPt in a PinS “Proceed VFR” procedure.

...

Heliport reference point (HRP). The designated location of a heliport or a landing location.

...

Initial departure fix (IDF). The terminal fix for the visual segment and the fix where the instrument phase of the PinS departure begins.

...

Landing location. A marked or unmarked landing area that has the same physical characteristics as a non-instrument heliport as per Annex 14, Volume II. (Example: the landing location could be a non-instrument heliport or could be located on a non-instrument runway.) visual heliport final approach and take-off area (FATO).

...

Manoeuvring visual segment (Manoeuvring-VS). PinS visual segment protected for the following manoeuvres for:

- *PinS approaches:* visual manoeuvre from the MAPt around the heliport or landing location to land from a direction other than directly from the MAPt.
- *PinS departures:* take-off in a direction other than directly to the IDF followed by visual manoeuvre to join the instrument segment at the IDF.

...

Minimum instrument meteorological conditions airspeed (V_{mini}). The minimum indicated airspeed at which a specific helicopter is certified to operate in instrument meteorological conditions.

...

Minimum sector altitude (MSA). The lowest altitude which may be used which will provide a minimum clearance of 300 m (1 000 ft) above all objects located in an area contained within a sector of a circle of 46 km (25 NM) radius centred on a radio-aid-to-navigation significant point, the aerodrome reference point (ARP), or the heliport reference point (HRP).

...

Point-in-space (PinS) approach. The point in space approach is based on a basic GNSS non-precision approach procedure designed for helicopters only. It is aligned with a reference point located to permit subsequent flight manoeuvring or approach and landing using visual manoeuvring in adequate visual conditions to see and avoid obstacles that includes both a visual and an instrument segment.

Point-in-space (PinS) departure. A departure procedure designed for helicopters only that includes both a visual and an instrument segment.

...

Point-in-space (PinS) visual segment. This is the segment of a helicopter PinS approach procedure from the MAPt to between a point (MAPt or IDF) and the heliport or the landing location for a PinS “proceed visually” procedure.

...

Visual segment design gradient (VSDG). The gradient of the visual segment in a PinS departure procedure. The visual segment connects the heliport or landing location with the initial departure fix (IDF) minimum crossing altitude (MCA).

...

Chapter 2
ABBREVIATIONS AND ACRONYMS

Editorial note.— Insert new abbreviations as follows:

Direct – VS	Direct visual segment
FHP	Fictitious heliport point
FHPCH	Fictitious heliport point crossing height
IDF	Initial departure fix
Manoeuvring-VS	Manoeuvring visual segment
MCA	Minimum crossing altitude
V _{mini}	Minimum instrument meteorological conditions indicated airspeed
VSDG	Visual segment design gradient

...

Section 4
ARRIVAL AND APPROACH PROCEDURES

Chapter 1
GENERAL CRITERIA FOR APPROACH/ARRIVAL PROCEDURES

*Editorial note.— Amend Tables I-4-1-1 and I-4-1-2, note “***” as follows:*

Table I-4-1-1. Speeds (IAS) for procedure calculations in kilometres per hour (km/h)

...

*** Helicopter point-in-space procedures based on basic GNSS may be designed using maximum speeds of 220 km/h for initial and intermediate segments and 165 km/h on final and missed approach segments or 165 km/h for initial and intermediate segments and 130 km/h on final and missed approach based on depending on the operational need. Refer to Part IV, Chapter-4.2.

...

Table I-4-1-2. Speeds (IAS) for procedure calculations in knots (kt)

...

*** Helicopter point-in-space procedures based on basic GNSS may be designed using maximum speeds of 120 KIAS for initial and intermediate segments and 90 KIAS on final and missed approach segments or 90 KIAS for initial and intermediate segments and 70 KIAS on final and missed approach ~~based on~~ depending on the operational need. Refer to Part IV, Chapter 1 2.

...

Part IV HELICOPTERS

Editorial note.— Insert the following text as new Chapter 1 and re-number the existing Chapter 1 as Chapter 2.

Chapter 1 PBN DEPARTURE PROCEDURES FOR HELICOPTERS USING BASIC GNSS OR SBAS RECEIVERS

1.1 GENERAL

1.1.1 Application

1.1.1.1 This chapter describes the criteria for PBN (RNAV and RNP) departure procedures specific to helicopter operations and includes criteria for the design of departure procedures from both instrument heliports or runways and heliports, or landing locations. Criteria for departures from heliports and landing locations are accommodated with point-in-space (PinS) departure procedures.

1.1.1.2 The general criteria of Part I, Section 3 and Part III, Sections 1, 2 and 3 as amplified or modified by the criteria in this chapter apply to RNAV and RNP departure procedures for helicopters.

1.2 HELICOPTER DEPARTURES FROM INSTRUMENT HELIPORTS OR RUNWAYS

(To be developed.)

1.3 HELICOPTER POINT-IN-SPACE (PINS) DEPARTURES FROM HELIPORTS OR LANDING LOCATIONS

1.3.1 PinS departure – General

1.3.1.1 *Description.* The PinS departure procedure consists of a visual segment followed by an instrument segment. The visual segment of the departure starts from the heliport or landing location and ends at the initial departure fix (IDF) at or above the IDF minimum crossing altitude (MCA). PinS departure procedures are constructed up to the IDF by applying the visual segment criteria, defined in this chapter, and beyond the IDF by applying the applicable PBN criteria, defined in Part III, Section I, Chapter 2. If the criteria for the visual segment can be met, the PinS departure procedure is annotated with the instruction: “proceed visually”. If the criteria for the visual segment cannot be met, the procedure is annotated with the instruction: “proceed VFR”. In the latter case there is no obstacle protection in visual segment. The obstacle protection after the IDF is the same as for a PinS departure with a “proceed visually” instruction.

Note 1.— The term “proceed VFR”, implies that the pilot can comply with VFR in the visual segment to see and avoid obstacles and can cross the IDF at or above the MCA.

Note 2.— The term “proceed visually” implies that pilots can navigate by visual reference and see and avoid obstacles, with visibility sufficient to return to the heliport if they cannot continue visually to cross the IDF at or above the IDF MCA. Visual flight may be conducted below minima required for VFR.

1.3.1.2 The “proceed visually” segment can be a direct visual segment (visual segment flown directly from the heliport or landing location to the IDF) or a manoeuvring visual segment (initial take off in a direction other than directly to the IDF).

1.3.2 PinS departure – Instrument phase – Description and protection

1.3.2.1 *Application of PBN Criteria.* For the construction of the instrument segment of the departure procedure, the appropriate helicopter navigation specifications identified in Part III, Section I, Chapter 2 shall be used. The navigation information is also used during the visual segment to aid in the identification of the IDF and, hence, only GNSS sensors may be used on these procedures.

1.3.2.1.1 *IDF fix tolerance.* The ATT, XTT and area semi-width values at the IDF are detailed in Part III, Section 1, Chapter 2.

1.3.2.1.2 Transition from visual segment to instrument segment of the PinS departure occurs at the IDF and requires the blending of the visual segment criteria with the applicable PBN protection areas at the IDF.

1.3.2.2 *Instrument segment of the PinS departure procedure.* The instrument segment consists of one or more legs and continues until the minimum en-route altitude is reached.

1.3.2.2.1 *Procedure design gradient (PDG).* The standard PDG is 5.0 per cent. It originates from the IDF MCA.

1.3.2.2.2 *Multiple PDGs.* Where multiple PDGs exist for a PinS departure, subsequent gradients in the departure shall be equal to or less than the PDG for preceding segment.

1.3.2.2.3 *Minimum obstacle clearance (MOC).* Between the earliest IDF and the IDF, the MOC is equal to 30 m (100 ft). Between the IDF and the latest IDF, the MOC is increased by a value corresponding to the PDG, and subsequently from the latest IDF is increased by 0.8 per cent of the distance from the latest IDF until the en-route MOC (300 m (1 000 ft), 600 m (2 000 ft) mountainous area) is reached. An alternative to increasing the PDG above the 5 per cent standard value beyond the IDF, would be to increase the IDF MCA to provide the necessary clearance over an obstacle in the subsequent departure leg while maintaining a lower PDG.

1.3.2.2.4 *IFR OIS dimensions.* The OIS dimensions shall be as follows:

- a) *Origin.* The IFR OIS originates at the earliest IDF.
- b) *Area semi-widths for PinS departures (instrument segment).* See Part III, Section 1, Chapter 2.

- c) *IFR OIS vertical dimension*. The OIS is level at the IDF MCA minus MOC from the earliest IDF until the latest IDF. It then has a gradient of (PDG minus 0.8 per cent).

1.3.3 PinS departure with a “proceed visually” instruction – Direct visual segment

1.3.3.1 *Track change at the IDF*. The maximum track change at the IDF is 30°.

1.3.3.2 *Visual segment design gradient (VSDG)*. The VSDG is the designed climb gradient. In the direct visual segment it is established by connecting the edge of the heliport or landing location safety area to the IDF at the IDF MCA. The VSDG shall not be less than 5 per cent. It may exceed 5 per cent when necessary to mitigate penetration of the visual or IFR obstacle identification surfaces (OIS) (see paragraph 1.3.3.8).

1.3.3.3 *Initial departure fix (IDF)*. The IDF shall be located:

- a) to provide sufficient visual reference from the heliport or landing location to the IDF to enable the helicopter to cross the IDF at or above the MCA;
- b) to cater for the minimum starting height of the subsequent instrument segment.

1.3.3.4 *Visual segment length*. The length of the visual segment shall be measured from the outer edge of the heliport or landing location safety area to the IDF. The minimum length of the visual segment shall be 1482 m (0.8 NM).

1.3.3.5 The visual OIS (see paragraph 1.3.3.6) terminates within the lateral boundaries of the instrument segment protection area. If the RNAV-1/RNP1 navigation specification is used for the instrument segment of flight, this results in a maximum visual segment length as follows:

- a) for no track change at the IDF, the maximum visual segment length is 13.9 km (7.5 NM);
- b) for $0^\circ < \text{track change} \leq 10^\circ$, the maximum visual segment length is 11.9 km (6.4 NM);
- c) for $10^\circ < \text{track change} \leq 20^\circ$, the maximum visual segment length is 9.3 km (5.0 NM);
- d) for $20^\circ < \text{track change} \leq 30^\circ$, the maximum visual segment length is 6.5 km (3.5 NM).

1.3.3.6 *Visual segment obstacle identification surface (OIS)*. The visual segment is protected by a Visual OIS. The dimensions of the Visual OIS are as follows:

- a) *Alignment*. The Visual OIS is constructed symmetrically around the direct track from the heliport/landing location to the IDF.
- b) *Origin*. The origin is perpendicular to the direct VS track at the boundary of the heliport or landing location safety area.
- c) *Width*. The area semi-width at the origin is 45 m (150 ft) and the area splays at 15° until the area connects with the instrument segment protection (see paragraph 1.3.3.7).
- d) *Slope*. The Visual OIS originates at the elevation of the heliport/landing location and rises to the IDF MCA minus 30 m (100 ft).

1.3.3.7 *Blending of visual segment with PBN criteria at the IDF.* Figure IV-1-1 depicts the vertical blending of the Visual OIS with a RNP-1/RNAV-1 OIS at the IDF. Figure IV-1-2 depicts the lateral blending of surfaces at the IDF (with track change at the IDF). The Visual OIS lateral splay is initially less than the instrument primary area semi-width. A portion of the instrument primary and secondary areas are subtended by the Visual OIS and need not be considered for obstacle assessment purposes because the visual segment is using a dead reckoning splay.

1.3.3.8 *Visual segment OIS penetration.* The Visual OIS shall be evaluated and any penetrating obstacles should be lit and marked if feasible. If operationally feasible, the VSDG should be increased to clear the critical visual segment obstacle. The minimum VSDG to clear the obstacle can be calculated by using an “adjusted” OIS. The “adjusted” OIS clears the obstacle, levels at the MCA minus 30 m (100 ft) and continues level until the origin of the IFR OIS at the earliest IDF. The minimum VSDG to clear the obstacle is then established by connecting its origin to the IDF MCA at the same along-track location as where the OIS becomes level. See Figure IV-1-3.

1.3.3.9 *Mitigation of obstacle penetration in the instrument segment.* To avoid obstacle penetration of the IFR OIS, the IDF MCA should be increased such that the IFR OIS remains clear, or a turn initiated, in preference to increasing the PDG above the standard 5 per cent. The resulting VSDG is increased and is determined by the elevation change between the boundary of the heliport or landing location safety area and the revised IDF MCA. See Figure IV-1-4.

1.3.4 PinS departure with a “proceed visually” instruction - Manoeuvring visual segment

1.3.4.1 *Manoeuvring VS protection.* A manoeuvring visual segment is protected for the following manoeuvre: the pilot takes-off in a direction other than directly to the IDF and then visually manoeuvres to join the initial instrument segment at the IDF.

1.3.4.2 This manoeuvring VS is protected by one sloping initial Visual OCS and one Visual OIS.

Note.— The protection provided for this visual segment is comparable with the one provided for PinS approaches followed by a manoeuvring visual segment (see paragraph 2.9.3).

1.3.4.3 IDF minimum crossing height (MCH is the actual height of MCA above the heliport/landing location). The MCH of the IDF for a PinS departure procedure with a manoeuvring visual segment shall not be less than 90 m (295 ft) above the heliport/landing location elevation.

1.3.4.4 *Sloping initial visual OCS*

1.3.4.4.1 The sloping initial visual OCS is aligned symmetrically on the centre line of the take-off climb surface.

Note.— If more than one take-off climb surface has to be considered, a Visual OCS is designed for each.

1.3.4.4.2 The sloping initial visual OCS originates at the outer edge of the heliport or landing location safety area (SA).

1.3.4.4.3 The width of the sloping initial visual OCS at its origin is equal to the width of the SA.

1.3.4.4.4 The outer edges splay from their origins at the edge of the SA, symmetrically around the centre line of the take-off climb surface, to an overall maximum width of 120 m, at which point the outer edges parallel the centreline. For the provision of day-only operations the splay is 10 per cent. For night operations the splay angle is increased to 15 per cent.

1.3.4.4.5 The elevation of the origin of the sloping initial visual OCS is equal to the heliport or landing location elevation.

1.3.4.4.6 The sloping initial visual OCS inclines at nominally 12.5 per cent from the heliport/landing location elevation to the point where the surface reaches the height of 152 m (500 ft) above heliport/landing location elevation.

1.3.4.5 *Visual OIS*

1.3.4.5.1 The visual OIS provides awareness in the area (called “manoeuvring area”) where the pilot is expected to manoeuvre visually from the initial departure track to join the initial instrument segment at the IDF.

1.3.4.5.2 *Description of the “manoeuvring area”*

1.3.4.5.2.1 The manoeuvring area is defined based on the following rules:

- a) the pilot initially climbs on the centre line of the take-off climb surface to reach the greater of the two following heights before manoeuvring toward the IDF:
 - 1) IDF MCH/2; and
 - 2) 90 m (295 ft) above the heliport/landing location elevation;
- b) the pilot continues to climb and accelerates so as to cross the IDF at or above the IDF MCA.

1.3.4.5.2.2 The outer boundaries of the manoeuvring area are based on the following assumed worst-case trajectories (see Figure IV-1-5):

- a) *first trajectory*: the pilot climbs in accordance with paragraph 1.3.4.5.2.1 a) above and then turns right to join the IDF;
- b) *second trajectory*: the pilot climbs in accordance with paragraph 1.3.4.5.2.1 a) above and then turns left to join the IDF.

1.3.4.5.2.3 The “manoeuvring area” is the area representing all the lines that originate at the IDF and connect with a “turn area” aligned symmetrically around the centre line of the take-off climb surface.

Note.— If more than one take-off climb surface has to be considered, the final “manoeuvring area” is the addition of all “manoeuvring areas” obtained.

1.3.4.5.2.4 Description of the “turn area” (see Table IV-1-1 and Figure IV-1-6)

1.3.4.5.2.4.1 The “turn area” is defined by an angle α each side of the centre line of the take-off climb surface (in order to consider a right turn and a left turn) and by a radius r .

Note.— The “manoeuvring area” can be reduced in size if a prominent obstacle is located near the heliport/landing location. In that case, after the initial climb, one turn direction to join the IDF is prohibited. Consequently, the “turn area” is defined only on one side of the centre line of the take-off climb surface (see Figure IV-1-9).

1.3.4.5.2.4.2 Radius (r) of the “turn area”:

- a) if the IDF MCH is equal or less than 183 m (600 ft) above the heliport/landing location elevation, r is constant and equal to 1 482 m (0.8 NM);
- b) if the IDF MCH of the procedure is more than 183 m (600 ft) above the heliport/landing location elevation, r increases linearly (185 m (0.1NM) for each additional 30 m (100 ft) above 183 m (600 ft)).

1.3.4.5.2.4.3 Angle (α) of the “turn area”:

- a) if the IDF MCH of the procedure is equal or less than 183 m (600 ft) above the heliport/landing location elevation, α is constant and equal to 50°;
- b) if the IDF MCH of the procedure is more than 183 m (600 ft) above the heliport/landing location elevation and equal or less than 304 m (1 000 ft) above the heliport/landing location elevation, α decreases linearly (5° for each additional 30 m (100 ft) above 183 m (600 ft));
- c) if the IDF MCH of the procedure is more than 304 m (1 000 ft) above the heliport/landing location elevation, α is constant and equal to 30°.

Note.— Where operationally beneficial, in order to extend the resulting “manoeuvring area”, the “turn area” can be extended by using wider angles on one side or on both sides of the centre line of the take-off climb surface.

Table IV-1-1
Definition of the “turn area” for a set of IDF MCH values

a) Units in meters for the IDF MCH and r:

IDF MCH	93 m*	123 m*	153 m*	183 m*	213 m*	243 m*	273 m*	303 m*
r	1 482 m	1 482 m	1 482 m	1 482 m	1 667 m	1 852 m	2 037 m	2 222 m
α	50°	50°	50°	50°	45°	40°	35°	30°

*Height above the heliport/landing location elevation.

b) Units in ft for the IDF MCH and in NM for r:

IDF MCH	300 ft*	400 ft*	500 ft*	600 ft*	700 ft*	800 ft*	900 ft*	1 000 ft*
r	0.8 NM	0.8 NM	0.8 NM	0.8 NM	0.9 NM	1 NM	1.1 NM	1.2 NM
α	50°	50°	50°	50°	45°	40°	35°	30°

*Height above the heliport/landing location elevation.

Note.— Taking into account the buffer of 741 m (0.4 NM) that will be applied to these values to define the OIS (see paragraph 1.3.4.5.3.2), these values are acceptable for all the operational scenarios regarding the temperature and the heliport or landing location elevation.

1.3.4.5.3 OIS definition

1.3.4.5.3.1 The OIS surface is defined by the “manoeuvring area” with an additional buffer equal to 741 m (0.4 NM) (see Figure IV-1-7).

Note.— If the initial take-off can be performed in an omni-directional fashion, the OIS is a surface aligned symmetrically on the course between the HRP and the IDF and that connects tangentially with the following: a circle centred on the IDF, having a radius equal to 741 m (0.4 NM), and a circle centred on the HRP, having a radius equal to (r + additional buffer value) (see Figure IV-1-8).

1.3.4.5.3.2 The OIS identifies obstacles in the “manoeuvring area” that are at or above 150 ft below the minimum height to which the pilot will initially climb before manoeuvring toward the IDF. Based on the above assumptions, the OIS is a surface, surrounding the “manoeuvring area”, and defined at the greater of the following heights:

- a) IDF MCH/2 – 46m (150 ft); and
- b) 46 m (150 ft) above the heliport/landing location elevation.

1.3.4.5.3.3 Obstacles that penetrate the OIS shall be charted, and may be marked and/or lighted when feasible.

1.3.4.6 *Maximum speed restrictions.* There are no maximum speed restrictions when operating on a manoeuvring visual segment.

1.3.4.7 *Manoeuvring visual segment length.* The minimum distance from HRP to IDF is 0.8 NM.

1.3.4.8 *Track change at the IDF.* The track change at the IDF shall be less than 30° for all the possible visual trajectories. Consequently, the angle between the initial instrument segment direction after the IDF and the direction of the “extreme” visual trajectories corresponding to the limits of the “manoeuvring area” shall be less than 30° (see figures IV-1-7, IV-1-8).

1.3.5 PinS departure with a “proceed VFR” instruction – Visual segment

1.3.5.1 Where “proceed visually” instruction is not suitable or possible, a PinS departure procedure with a “proceed VFR” instruction shall be designed.

1.3.5.2 *There is no obstacle protection in the visual segment.* The pilot complies with VFR to see and avoid obstacles when proceeding from the heliport or landing location to the IDF, to cross at or above the IDF MCA.

1.4 PROMULGATION

1.4.1 *Procedure identification.* PinS departures shall be titled “RNAV XXXXX DEPARTURE” where XXXXX is the name of the last waypoint in the departure procedure. The plan view shall include a note that the procedure is Cat H only.

1.4.2 The IDF shall be charted as a “fly-by” waypoint.

1.4.3 *Departure climb table.* A departure climb table shall be provided in the profile view with the visual segment design gradient (VSDG) for Direct-VS and procedure design gradient (PDG) in m/km (ft/NM) for each instrument segment. Additional information shall include the MCA for the end waypoint for each segment. If a segment exceeds the PDG or VSDG standard of 5 per cent, the segment gradient shall also be charted in per cent, to the nearest one-tenth of a per cent, in the departure climb table. A PDG greater than 5 per cent shall also be annotated on the chart. Where multiple PDGs exist for a PinS departure, e.g. due to multiple obstacle clearance requirements and/or air traffic control requirements, or to meet enroute minimum crossing altitude requirements, the highest computed climb gradient for that segment shall be published.

1.4.4 *Charting of the MCA.* MCAs for all waypoints in the procedure shall be charted. On the profile view the MCA of each departure waypoint shall be charted as “YYYY” where “YYYY” is the MCA in metres (feet). MCA information shall also be included on the plan view. The MCA shall be charted adjacent the waypoint to which it applies.

1.4.5 *Segment tracks and lengths.* Segment tracks and lengths shall be charted.

1.4.6 *Obstacles.* Obstacles penetrating the visual OIS shall be charted.

1.4.7 *Additional information for the manoeuvring-VS*

1.4.7.1 The centre line(s) and direction(s) of the take-off climb surface(s) taken into account for the protection of the manoeuvring visual segment shall be indicated on the chart.

1.4.7.2 The “manoeuvring area” shall be represented on the chart either in an inset on the plan view, or on a continuation sheet or the verso of the chart. Information depicted in the inset shall be charted to scale. If the manoeuvring area is not depicted in an inset, the plan view shall contain an annotation directing the pilot to the continuation sheet or the verso of the chart.

1.4.7.3 If the “manoeuvring area” is reduced in size in order to take into account a significant obstacle, restricted use airspace or environmentally sensitive areas located near the heliport/landing location, the following elements shall be indicated on the chart:

- a) the boundaries of the manoeuvring area;
- b) the location of the significant obstacle/restricted use airspace/environmentally sensitive area; and
- c) the boundaries of any ‘no manoeuvring’ area annotated ‘No manoeuvring’.

1.4.7.4 The departure shall be annotated “Proceed visually to the IDF” or “Proceed VFR to the IDF” as appropriate.

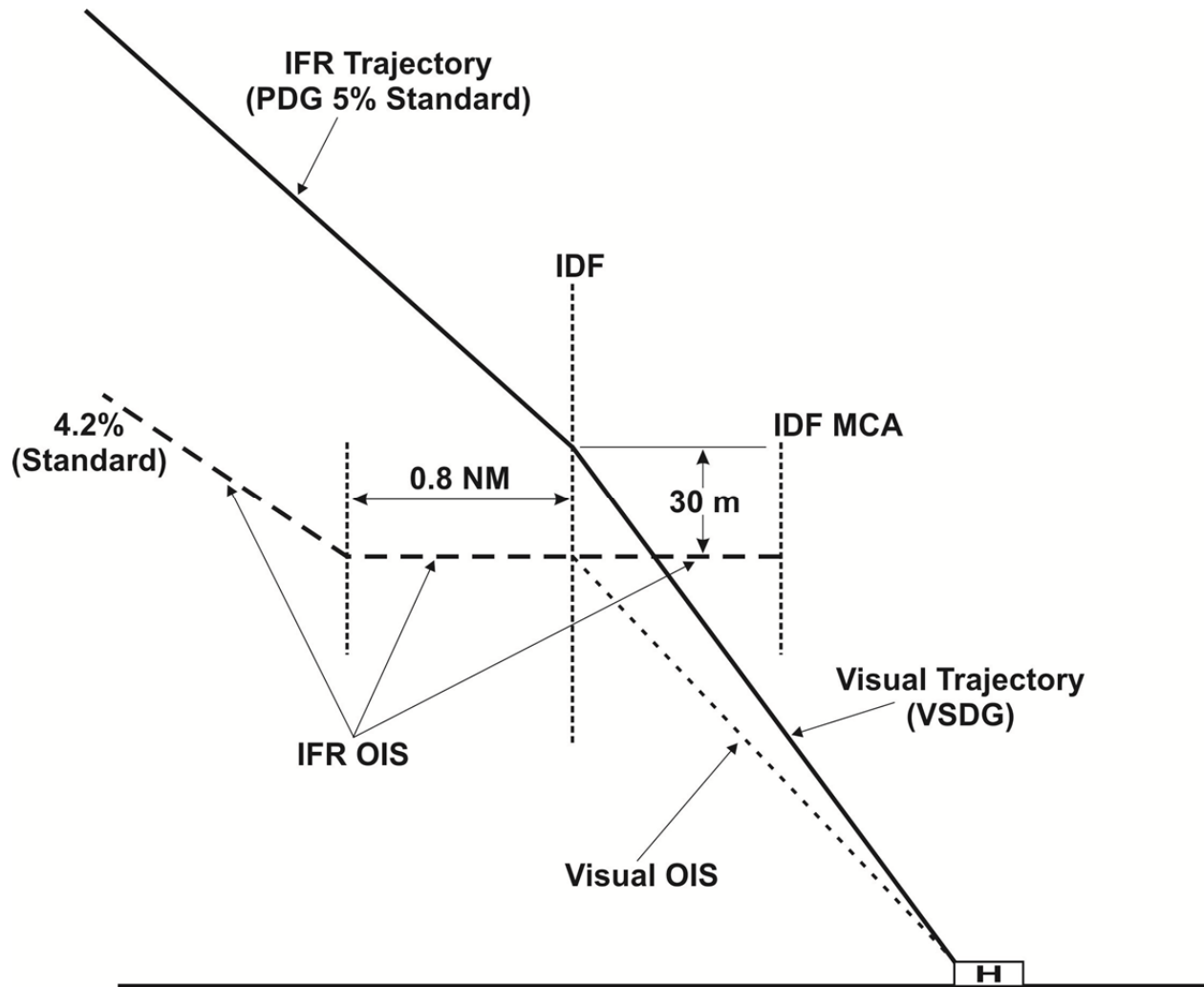

Figure IV-1-1. Vertical blending of visual segment OIS and IFR

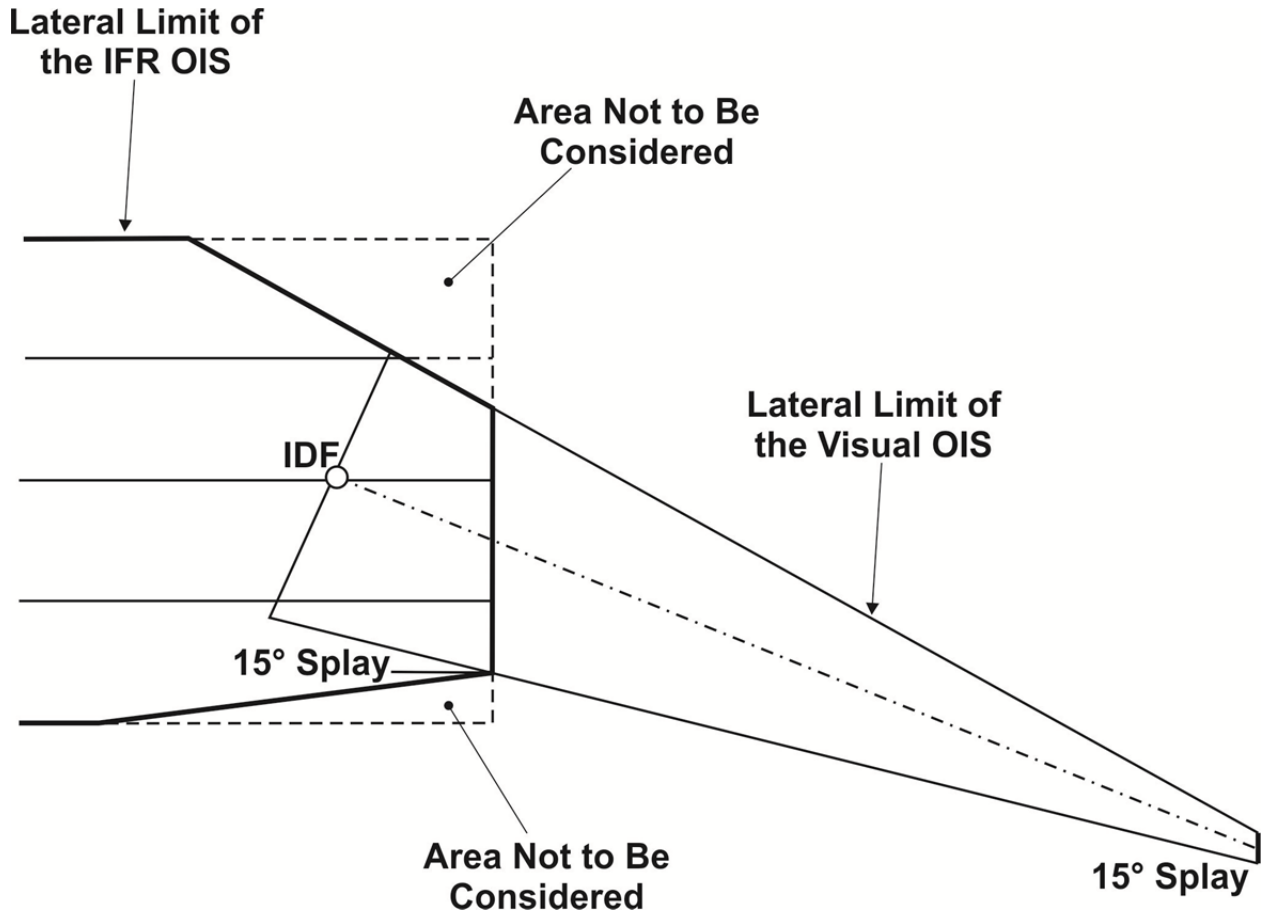

Figure IV-1-2. Lateral blending with track change at IDF

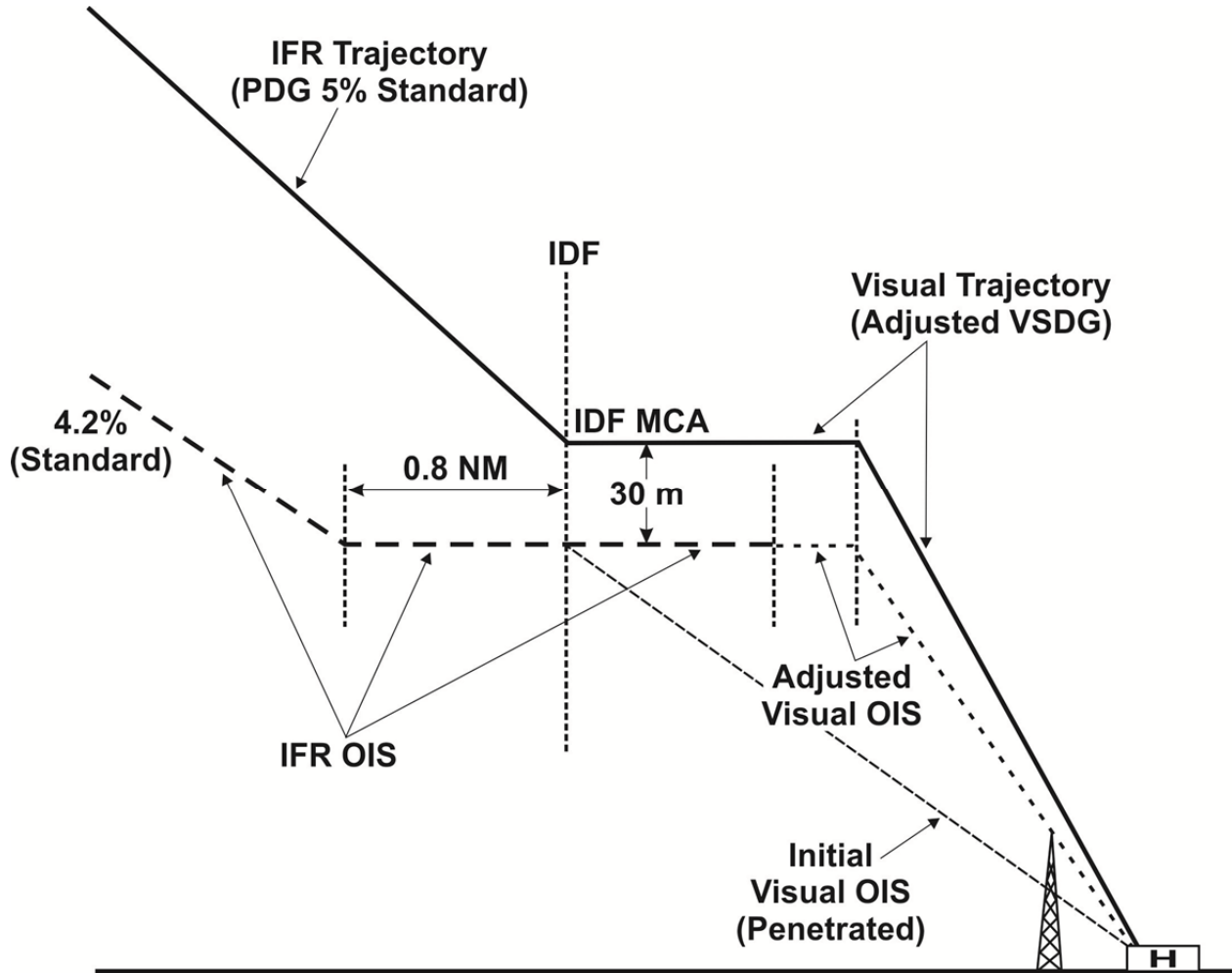

Figure IV-1-3. Mitigation of OIS penetration by raising the VSDG

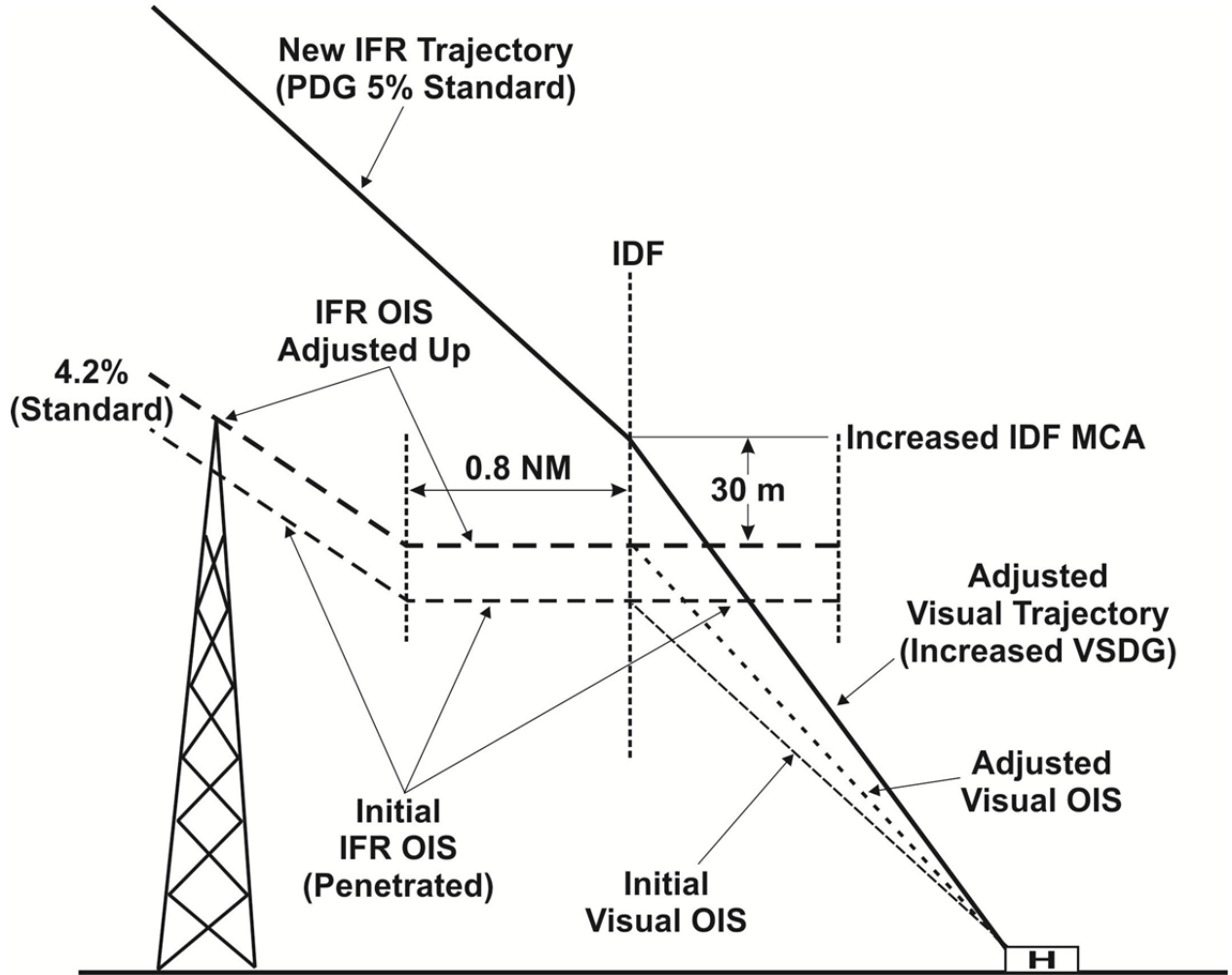

Figure IV-1-4. Mitigation of obstacle penetration in the instrument segment by increasing the IDF MCA

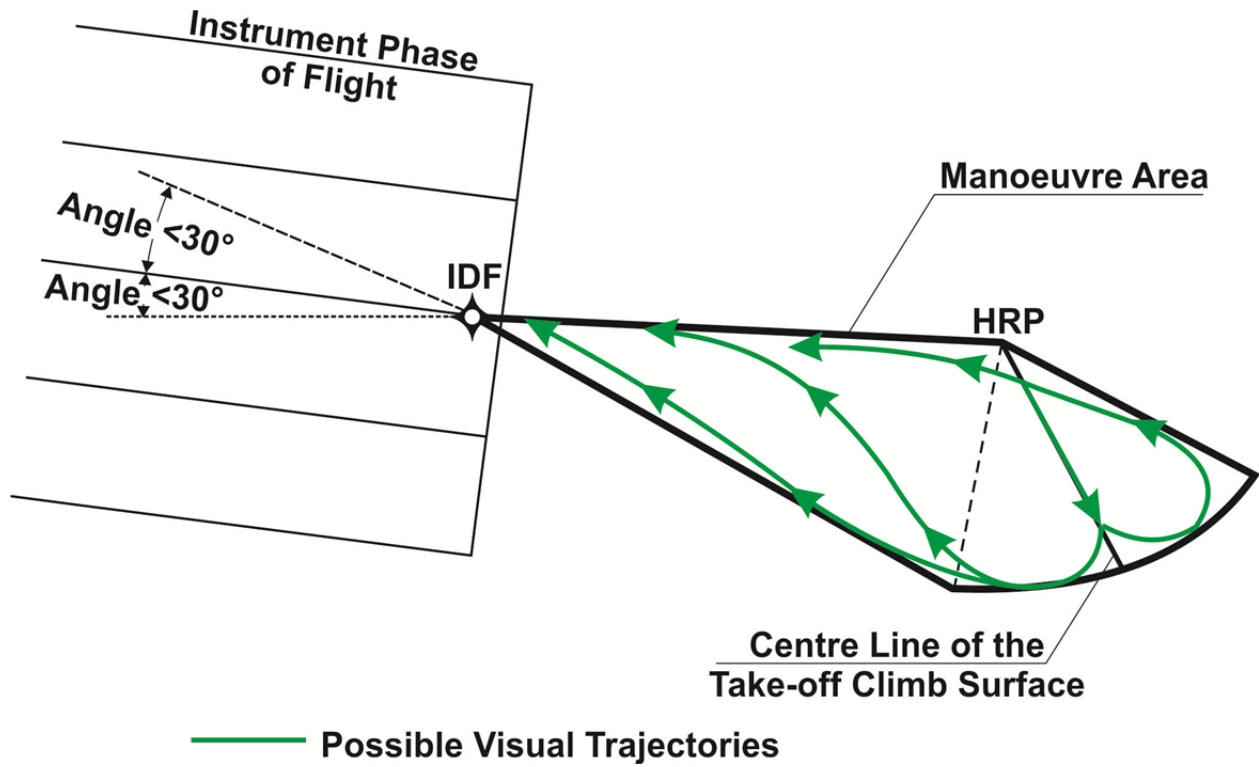

Figure IV-1-5. Manoeuvring visual segment representation of the possible trajectories defining the “manoeuvring area” for a defined centre line of the take-off climb surface

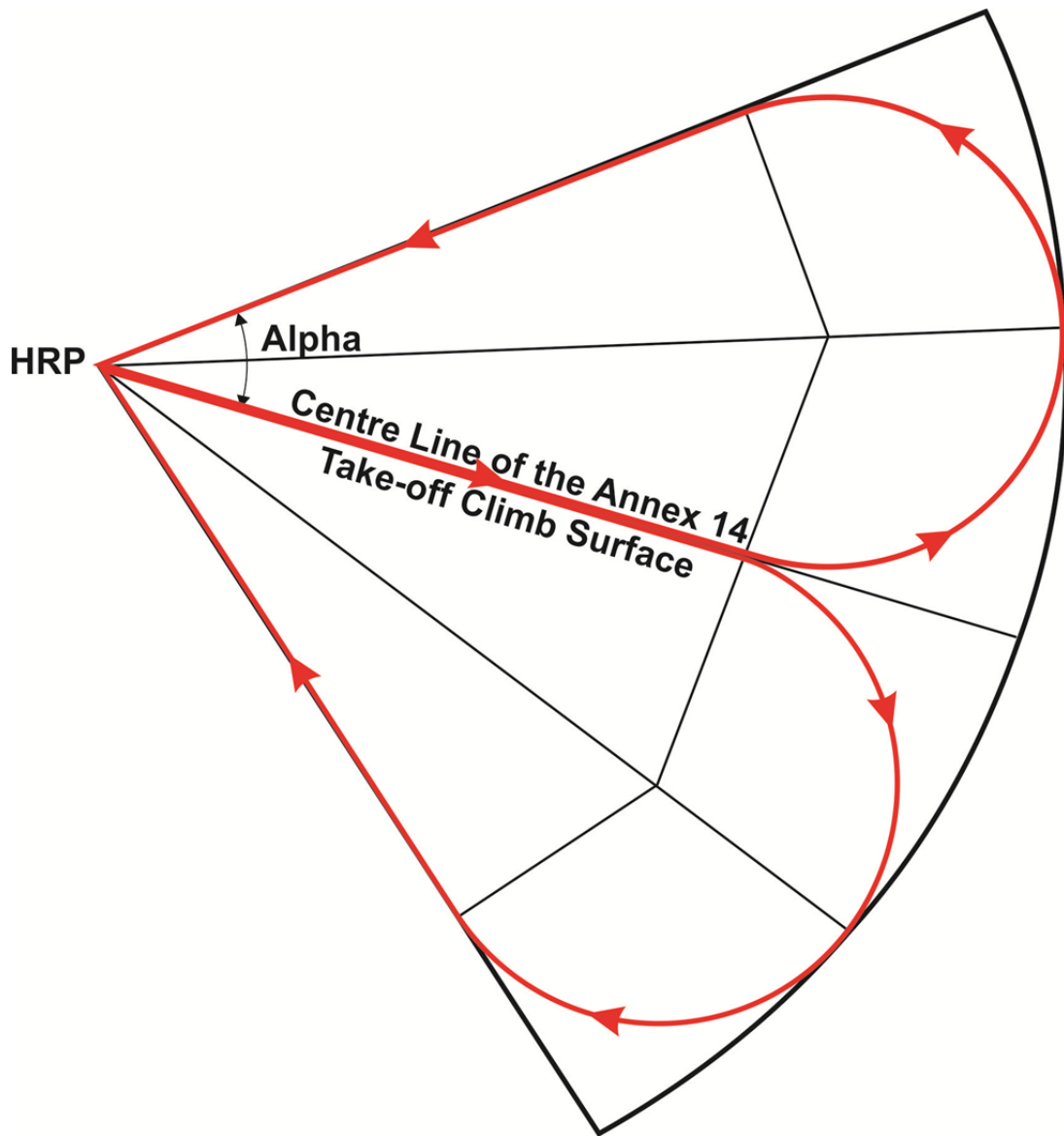

Figure IV-1-6. Manoeuvring visual segment description of the "turn area"

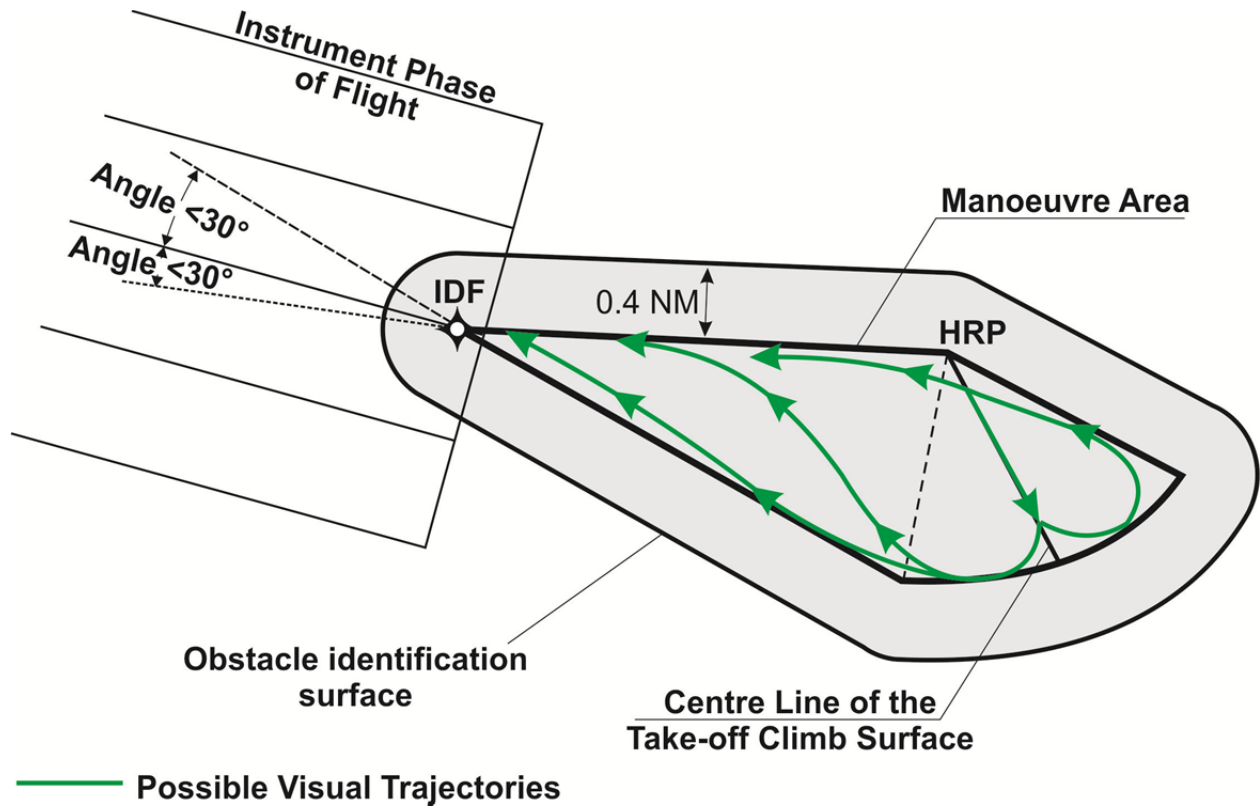

Figure IV-1-7. Manoeuvring visual segment representation of the level OIS for a defined centre line of the take-off climb surface

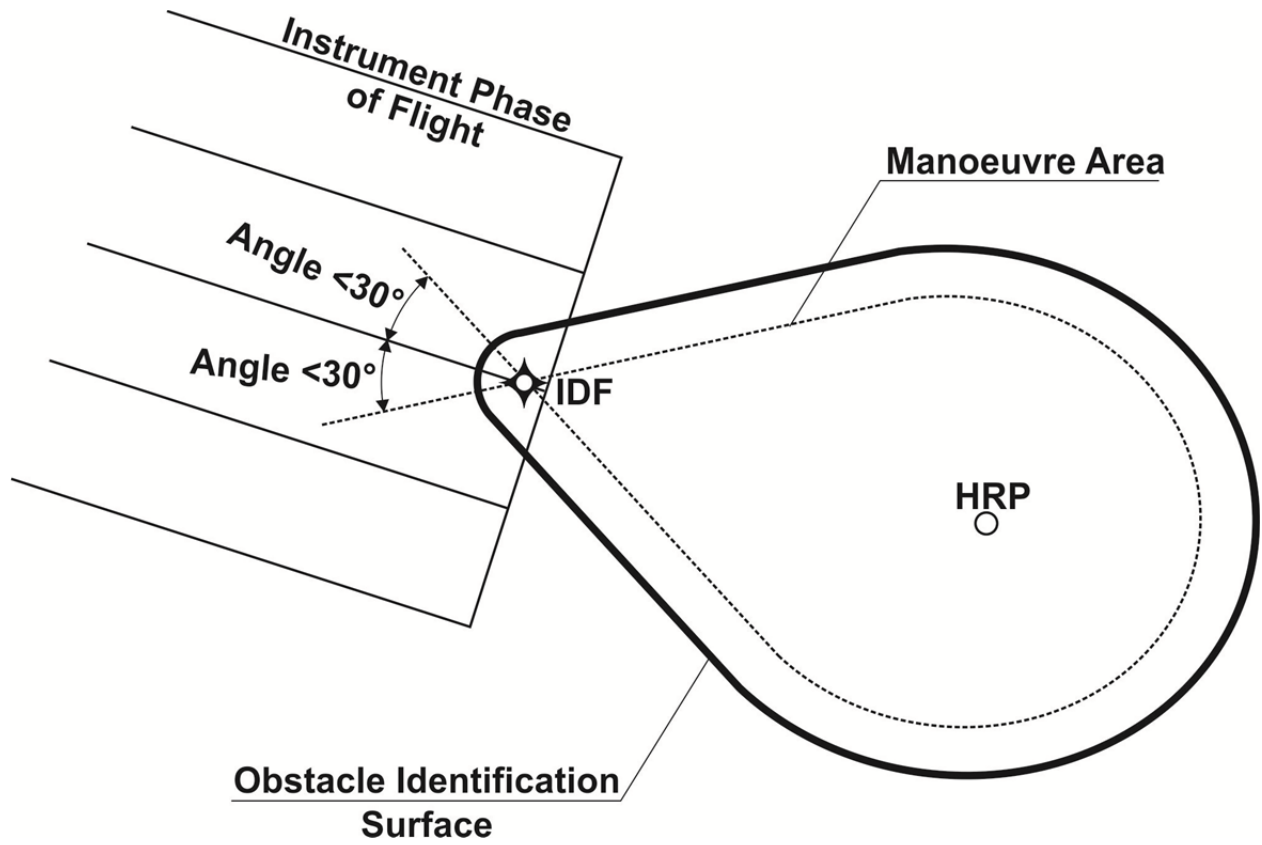
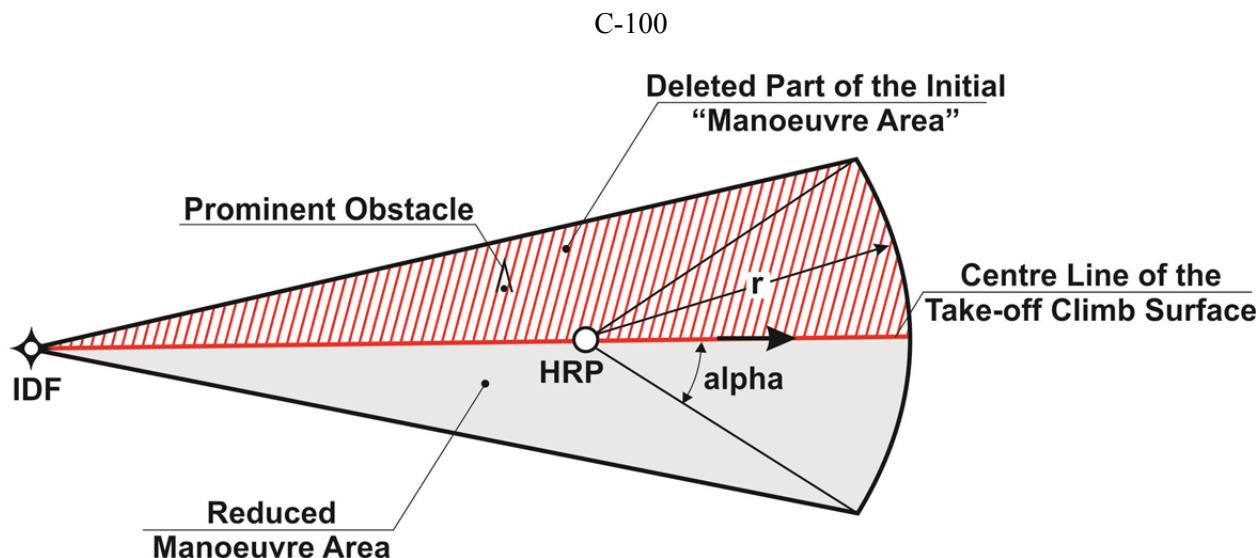

Figure IV-1-8. Manoeuvring visual segment representation of the level OIS if the initial take-off can be performed in an omni-directional way



Reduction of the Manoeuvring area due to a prominent obstacle (left turn prohibited)

Figure IV-1-9. Manoeuvring visual segment reduction of the “manoeuvring area” due to a prominent obstacle

Chapter 1-2
AREA NAVIGATION (RNAV) POINT-IN-SPACE (PinS)
APPROACH PROCEDURES FOR HELICOPTERS
USING BASIC GNSS RECEIVERS
POINT-IN-SPACE (PinS) RNP APCH APPROACH PROCEDURES
FOR HELICOPTERS DOWN TO LNAV MINIMA

Editorial note.— Re-number subsequent paragraphs accordingly to reflect the new chapter number.

1.9 VISUAL SEGMENT

2.9 PinS APPROACH PROCEDURES WITH A “PROCEED VISUALLY” INSTRUCTION

1.9.1 *General.* The visual segment connects the point-in-space (PinS) to the landing location. This can be a direct visual segment as described below. This connection can also be accomplished via a route or by manoeuvring.

— *Note.*— *Guidance for manoeuvring and route visual segments is currently under development.*

Note.— *In circumstances where a “proceed visually” instruction is not suitable or possible, a PinS approach procedure with a “proceed VFR” instruction can be designed (see Section 2.10).*

2.9.1 *General.* A direct visual segment or a manoeuvring visual segment connects the PinS (the MAPt) to the heliport or the landing location. This provides the pilot flying a PinS instrument approach procedure with a visual segment to proceed visually from the MAPt to the heliport or landing location.

Note.— This connection can also be accomplished via a Route Visual Segment. Procedure design criteria for route visual segments are currently under development.

~~1.9.2.2.9.2~~ *Direct-visual segment (VS).* The Direct-VS connects the PinS to the heliport or landing location; this can be either direct to the heliport or landing location or via a descent point where a limited track change may occur. The Direct-VS provides the pilot flying a PinS instrument approach procedure with a visual segment to proceed visually from the MAPt to the heliport or landing location.

Note.— The “landing location” is a landing area that has the same physical characteristics as a non-instrument heliport as per Annex 14, Volume II. (Example: the landing location could be a non-instrument heliport or could be located on a non-instrument runway.)

...

~~1.9.2.2.1~~~~2.9.2.2.1~~ OCS alignment, slope, origination base width, and lateral dimensions. The OCS is aligned symmetrically on the course between HRP and MAPt. If a DP is established with a change of track at the DP, the OCS is aligned symmetrically on the course between the HRP and the DP. See Figures-IV-1-7, IV-1-8 and IV-1-9 IV-2-7, IV-2-8 and IV-2-9.

...

Editorial note.— Insert new paragraphs 2.9.3, 2.10 and 2.11 as follows:

2.9.3 *Manoeuvring-visual segment (VS)*

2.9.3.1 A Manoeuvring-VS is designed to protect a manoeuvre whereby the pilot visually acquires the heliport or landing location, or visual references associated with it, by the MAPt and visually manoeuvres around the heliport or landing location to land from a direction other than directly from the MAPt.

2.9.3.1.1 This Manoeuvring-VS is protected by a level obstacle clearance surface (OCS), the obstacle limitation surfaces (sloping OCS and OIS) and the safety area (SA) associated with the FATO (See Annex 14, Vol II, chapter 3 section 3.1).

2.9.3.1.2 The OCH for a PinS procedure followed by a manoeuvring visual segment shall not be less than 90 m (295 ft) above the heliport/landing location elevation.

2.9.3.2 *Level obstacle clearance surface (OCS)*

2.9.3.2.1 The level OCS is a level surface at an altitude of OCA – 76 m (250 ft).

2.9.3.2.2 From the MAPt to abeam the HRP the level OCS is aligned symmetrically on the course between HRP and MAPt with a semi-width of 741 m (0.4 NM). Beyond the HRP, this surface connects tangentially with a circle centred on the HRP, this circle having a radius equal to 741 m (0.4NM).

2.9.3.3 *Obstacle identification surface (OIS)*

2.9.3.3.1 The OIS provides awareness in the area where the pilot is expected to manoeuvre before being aligned on the centre line of the approach surface.

2.9.3.3.2 *Definition of the “manoeuvre area”*

2.9.3.3.2.1 The “manoeuvre area” corresponds to the area where the pilot is expected to manoeuvre from the MAPt to the point where it is aligned on the final landing.

2.9.3.3.2.2 The “manoeuvre area” is the area enclosed by all the lines that originate at the MAPt and connect with a “base turn area” aligned symmetrically around the centre line of the approach surface (see figures IV-2-10 and figures IV-2-11).

Note 1.— If more than one approach direction has to be considered, the final “manoeuvre area” is the combination of all the “manoeuvre areas” obtained.

Note 2.— Trajectories that have been considered to define the shape of this “manoeuvre area” are:

- a) *the pilot flies at the OCA/H directly from the MAPt to the heliport/landing location and then performs a base turn to descend and align on the centre line of the approach surface;*
- b) *the pilot starts from the MAPt but diverges from the ‘MAPt-HRP’ axis in order to manoeuvre to align on the centre line of the approach surface.*

2.9.3.3.2.3 Description “base-turn area” (see Table IV-2-1 and Figure IV-2-12).

2.9.3.3.2.3.1 The “base turn area” is defined by an angle α each side of the centre line of the approach surface (to protect both possible manoeuvres of a base turn (on the right side and on the left side) to join the centre line of the approach surface) and by a radius r .

2.9.3.3.2.3.2 Radius (r) of the “base turn area”:

- a) if the OCH of the procedure is equal or less than 183 m (600 ft) above the heliport/landing location elevation, r is constant and equal to 1482 m (0.8 NM);
- b) if the OCH of the procedure is more than 183 m (600 ft) above the heliport/landing location elevation, r increases linearly (185 m (0.1NM) for each additional 30 m (100 ft) above 183 m (600 ft)).

2.9.3.3.2.3.3 Angle (α) of the “base turn area”:

- a) if the OCH of the procedure is equal or less than 183 m (600 ft) above the heliport/landing location elevation, α is constant and equal to 50°;
- b) if the OCH of the procedure is more than 183 m (600 ft) above the heliport/landing location elevation and equal or less than 304 m (1000 ft) above the heliport/landing location elevation, α decreases linearly (5° for each additional 30 m (100 ft) above 183 m (600 ft));
- c) if the OCH of the procedure is more than 304 m (1000 ft) above the heliport/landing location elevation, α is constant and equal to 30°.

Table IV-2-1. Definition of the “base turn area” for a set of OCH values

a) Units in meter for OCH and r:

OCH	93 m*	123 m*	153 m*	183 m*	213 m*	243 m*	273 m*	303 m*
r	1 482 m	1 482 m	1 482 m	1 482 m	1 667 m	1 852 m	2 037 m	2 222 m
α	50°	50°	50°	50°	45°	40°	35°	30°

*Height above the heliport/landing location elevation.

b) Units in ft for the OCH and in NM for r:

OCH	300 ft*	400 ft*	500 ft*	600 ft*	700 ft*	800 ft*	900 ft*	1 000 ft*
r	0.8 NM	0.8 NM	0.8 NM	0.8 NM	0.9 NM	1 NM	1.1 NM	1.2 NM
α	50°	50°	50°	50°	45°	40°	35°	30°

*Height above the heliport/landing location elevation.

Note.— Taking into account the buffer of 741 m (0.4 NM) that will be applied to these values to define the OIS (see paragraph 2.9.3.3.3.2), these values are acceptable for all the operational scenarios regarding the temperature and the heliport or landing location elevation.

2.9.3.3.2.3.4 *Base turn area on one side of the MAPt-HRP axis.* When turns are limited to one side of the MAPt-HRP axis, and the turn over the HRP is greater than 30°, the base turn area may not be sufficient to contain the manoeuvre. In these circumstances (when $\alpha > 30^\circ$), the angle between the edge of the base turn area and the extended MAPt-HRP axis is held at 30° and results in an increase to the base turn area (see Figure IV-2-11B).

2.9.3.3.2.3.5 Where operationally beneficial, in order to extend the resulting “manoeuvre area”, the “base turn area” can be extended by using wider angles on one side or on both sides of the centre line of the approach surface.

2.9.3.3.3 *OIS definition*

2.9.3.3.3.1 The OIS is a level surface at a height of (OCH (height above the heliport/landing location elevation)/2 – 46 m (150 ft)) or at a height of 46 m (150 ft) above the heliport/landing location elevation, whichever is greater.

2.9.3.3.3.2 The OIS surface is defined by the “Manoeuvre area” with an additional buffer of a value equal to 741 m (0.4 NM) (see figures IV-2-13 and IV-2-14).

Note.— If all the directions to land have to be considered, the OIS is a surface aligned symmetrically on the course between the MAPt and the HRP and that connects tangentially with the two following circles: the circle centred on the MAPt and having a radius equal to 741 m (0.4 NM) and the circle centred on the HRP and having a radius equal to (r + additional buffer value) (see figure IV-2-15).

2.9.3.4 *Sloping OCS*

2.9.3.4.1 The sloping OCS is aligned symmetrically on the centre line of the approach surface.

Note.— If more than one approach surface has to be considered, a sloping OCS is designed for each.

2.9.3.4.2 The sloping OCS originates at the outer edge of the heliport or landing location SA.

2.9.3.4.3 The width of the sloping OCS at its origin is equal to the width of the SA.

2.9.3.4.4 The outer edges splay from their origins at the edge of the SA, symmetrically around the centre line of the approach surface, to an overall maximum width of 120 m, at which point the outer edges parallel the centreline. For the provision of day-only operations the splay is 10 per cent. For night operations the splay angle is increased to 15 per cent.

2.9.3.4.5 The elevation of the origin of the sloping OCS is equal to the heliport or landing location elevation.

2.9.3.4.6 The sloping OCS slopes upward at nominally 12.5 per cent from the heliport or landing location elevation up to the point where the surface reaches the height of 152 m above HRP.

Note 1.— The calculation of the SA size and the SA outer edges used to establish the origination base width, is aircraft dependent and needs to be provided with other heliport or landing location information to develop a Manoeuvring-VS for a helicopter PinS instrument approach procedure.

Note 2.— The nominal 12.5 per cent OCS slope is consistent with an assumption of a descent angle of 8.3° for this final descent and the OCS of 1.12° below this descent angle.

2.9.3.5 *Obstacle clearance*

2.9.3.5.1 No obstacles should penetrate the level OCS or the sloping OCS. Obstacles that penetrate the OIS shall be documented and charted. Other obstacles may be documented and charted if deemed necessary even if they not penetrate the different OIS.

2.9.3.5.2 *Method for reducing OCA/H*

2.9.3.5.2.1 Where operationally beneficial, a relevant obstacle infringing the level OCS less than 741 m (0.4 NM) from the HRP, may be ignored for this OCS assessment if:

- a) flyover of the heliport or landing location during the visual manoeuvre is prohibited;
- b) the obstacle is not inside the “manoeuvre area” that is reduced accordingly (see paragraph 2.9.3.5.2.2);
- c) the obstacle does not penetrate the sloping OCS and the IFR protection areas.

2.9.3.5.2.2 In order to disregard an obstacle as explained in paragraph 2.9.3.5.2.1, the “manoeuvre area” needs to be reduced as follows. As flyover of the heliport or landing location is prohibited, the “base turn area” (see paragraph 2.9.3.3.2.3) shall be defined only on one side of the centre line of the approach surface and the resulting “manoeuvre area” is an area delimited by the MAPt-HRP axis and the centre line of the approach surface (see Figures IV-2-16 and IV-2-17).

2.9.3.6 *Segment length.* The minimum MAPt/HRP distance is dependent on the maximum speed in the final approach segment of the instrument procedure and shall be as follows:

a) 130 km/h (70KIAS): 1.00 km (0.54NM);

b) 165 km/h (90KIAS): 1.60 km (0.85NM).

2.9.3.7 *Visibility requirements.* The visibility requirements to fly a manoeuvring visual segment shall not be less than the MAPt/HRP distance or than the value of r defined in paragraph 2.9.3.3.2.3.2, whichever is greater.

2.9.3.8 *Authorised IFR final approach segment direction.* Angle between the IFR final approach segment direction and the limits of the manoeuvre area defined in paragraph 2.9.3.3.2 is less than 30° (see Figures IV-2-13, IV-2-14 and IV-2-15).

2.9.3.9 *Specific charting requirements regarding the manoeuvring visual segment*

2.9.3.9.1 The centre line(s) of the approach surface(s) taken into account for the protection of this Manoeuvring visual segment shall be indicated on the chart.

2.9.3.9.2 The “Manoeuvre area” (see paragraph 2.9.3.3.2) and obstacles that penetrate the OIS (see paragraph 2.9.3.5.1) shall be depicted on the chart.

2.9.3.9.3 If the method for reducing the OCA/H has been used (see paragraph 2.9.3.5.2), it shall be indicated on the chart that flyover of the heliport or landing location during the visual manoeuvre is prohibited. The “manoeuvre area”, reduced accordingly (see paragraph 2.9.3.5.2.2), shall be depicted on the chart and the area where the prominent obstacle exists shall be depicted as a “no manoeuvring area”.

2.10 VISUAL SEGMENT FOR PinS APPROACH PROCEDURE WITH A “PROCEED VFR” INSTRUCTION

2.10.1 Where a “proceed visually” instruction is not suitable or possible, a PinS approach procedure with a “proceed VFR” instruction shall be designed.

2.10.2 There is no obstacle protection in the visual segment. The pilot shall comply with VFR to see and avoid obstacles when proceeding from the MAPt to the heliport or landing location.

2.11 PinS APPROACH PROCEDURE WITH A “PROCEED VFR” INSTRUCTION HEIGHT ABOVE SURFACE (HAS) DIAGRAM

2.11.1 *General.* To aid the pilot in transition from IFR to VFR at the MAPt for a PinS approach procedure with a “proceed VFR” instruction, a HAS diagram shall be charted. The HAS diagram is centred on the MAPt and depicts the course into the MAPt.

2.11.2 *HAS diagram requirements.* The radius of the HAS diagram, centred on the MAPt of the PinS approach procedure with a “proceed VFR” instruction, is at least 1.5 km (0.8 NM). This minimum value may be increased depending on State-specific requirements for helicopter VFR operations. The difference in height between the OCA and the elevation of the highest terrain or water within 1.5 km (0.8 NM), or other higher value required by the State, of the MAPt shall be charted. The inbound course to the MAPt shall also be charted. An example of a HAS diagram is depicted in Figure IV-2-18. The HAS value in the example is 467 ft and the final approach course to the MAPt is 028°.

End of new text.

~~1.10~~ 2.12 PROMULGATION

~~1.10.1~~ 2.12.1 *Procedure identification.* ~~For helicopter point-in-space approaches, the title of the IAC should include the final approach course (three numeric characters); e.g., RNAV (GNSS) 036. If the approach is restricted to Class B and C receivers this shall be included in sub-script parentheses, in the title. For example:~~

~~RNAV_(GNSS Class B & C only) 023~~

~~The term “CAT H” should be prominently displayed in the plan view but not be included in the title, and the minimums should include the term CAT H. The point-in-space PinS approaches shall be titled “RNAV XXX” where XXX is the final approach course. PinS approach procedures shall not be published on the same IAP chart as aeroplane (CAT A, B, C, D) and helicopter (CAT H) procedures to runways.~~

~~—Note.—The sensor does not form part of the ATC clearance.~~

2.12.2 The plan view shall include:

- a) heliport/landing location name and elevation to the nearest metre or foot;
- b) bearing to the nearest degree, and distance to the nearest two-tenths of a kilometre or tenth of a nautical mile from the missed approach point (MAPt) to the heliport/landing location;
- c) textual instructions to “Proceed VFR from xxxx” (MAPt identifier) or “Proceed visually from xxxx” (MAPt identifier) or “Manoeuvre visually from xxxx” (MAPt identifier), as appropriate;
- d) obstacles, if not included in an inset; and
- e) a note that the procedure is for CAT H only.

~~1.10.2~~ 2.12.3 For point-in-space approaches annotated “Proceed visually from (MAPt)” ~~any number of serving more than one heliports may be served by the procedure. Enter~~, the heliport name(s), heliport elevation(s), ~~and~~ the bearing (to the nearest degree) and the distance (to the nearest two-tenths of

a kilometer (tenth NM)) from MAPt to the Aerodrome Reference Point (ARP) of the heliport each HRP shall be included; e.g. **MCCURTAIN MEMORIAL HOSPITAL, ELEV 693', 123/3.2.**

~~1.10.3-2.12.4~~ *Speed limitation.* ~~The speed limitation must be clearly indicated on the published IAP chart. For example “The final and missed approach airspeed must not exceed xx KIAS”.~~ Airspeed restrictions shall be depicted on the chart textually as “Maximum airspeed xxx km/h (xxx KIAS)” when less than 165 km/h (90 KIAS).

~~1.10.4-2.12.5~~ *Descent gradient.* Where an operational requirement exists, a gradient of as much as 13.2 per cent (800 ft/NM) may be authorized, provided that the gradient used is depicted on the approach chart.

2.12.6 Appropriate obstacles shall be charted.

2.12.7 An inset shall be used to show the following:

- a) obstacles that penetrate the OIS;
- b) final approach course to the MAPt;
- c) text for either “Proceed VFR from (MAPt)”, or “Proceed visually from (MAPt)”, as appropriate;
- d) for “Proceed visually” PinS procedures with a direct visual segment, the descent point (DP), if established, and bearings and distances from MAPt to DP and from MAPt or DP to the heliport/landing location;
- e) for “Proceed visually” PinS procedures with a manoeuvring visual segment(s), only the ingress track(s) and the boundary of the manoeuvring area without dimensions are charted;
- f) for “Proceed visually” PinS procedures with a “no manoeuvring” area, the text “no manoeuvring” will be shown, along with the boundary of the “no manoeuvring” area. The “no manoeuvring” area shall be hachured.
- g) for “Proceed visually” PinS procedures where over-flight of the heliport or landing location is prohibited, the bearing and distance, from the MAPt to the heliport or landing location, on a line from the MAPt to the boundary of the prohibited over-flight area; and
- h) for “Proceed VFR” procedures, only a height above surface (HAS) diagram, which shall include the difference in height between the OCA and the elevation of the highest terrain or water surface and any relevant obstacles within 1.5km (0.8NM) of the MAPt.

Note. — *The inset specified above is a separate framed diagram, located on the plan view, on the verso of the chart, or on a continuation sheet; which is charted to scale and is used to show pertinent information “close-in” to the heliport or landing location.*

2.12.8 The inset for either type of PinS procedure shall not be used to depict instructions, non-operational notes, descent gradients/angles, or missed approach track or instructions.

2.12.9 The profile view shall contain information relating to the instrument procedure profile and the direct visual segment profile, if it exists, with the text “Proceed VFR” or “Proceed visually”, as

appropriate. There is no profile view information for either “Proceed VFR” or “Proceed Visually” with a manoeuver visual segment procedures. The profile view of the direct visual segment shall include:

- a) fixes, altitudes and distances up to the MAPt;
- b) the profile and track from the MAPt to the heliport or landing location;
- c) the descent point if established;
- d) the descent angle from the MAPt or DP;
- e) the heliport crossing height (HCH);
- f) the text “Proceed visually”, which shall be located under the visual segment profile; and
- g) a descent table should be shown indicating descent angle and descent rate in metres per minute (feet per minute) for appropriate speeds for applicable segments, i.e. final approach fix (FAF) to step down fix (SDF), SDF to missed approach point (MAPt), and descent point (DP) to heliport reference point (HRP).

Note. — *The descent table may be placed in the lower left or right corner of the plan view directly above the profile view.*

Editorial note.— *Re-number* subsequent paragraphs accordingly.

Editorial note.— Re-number existing figures and add the following figures in the re-numbered Chapter 2 of Part IV:

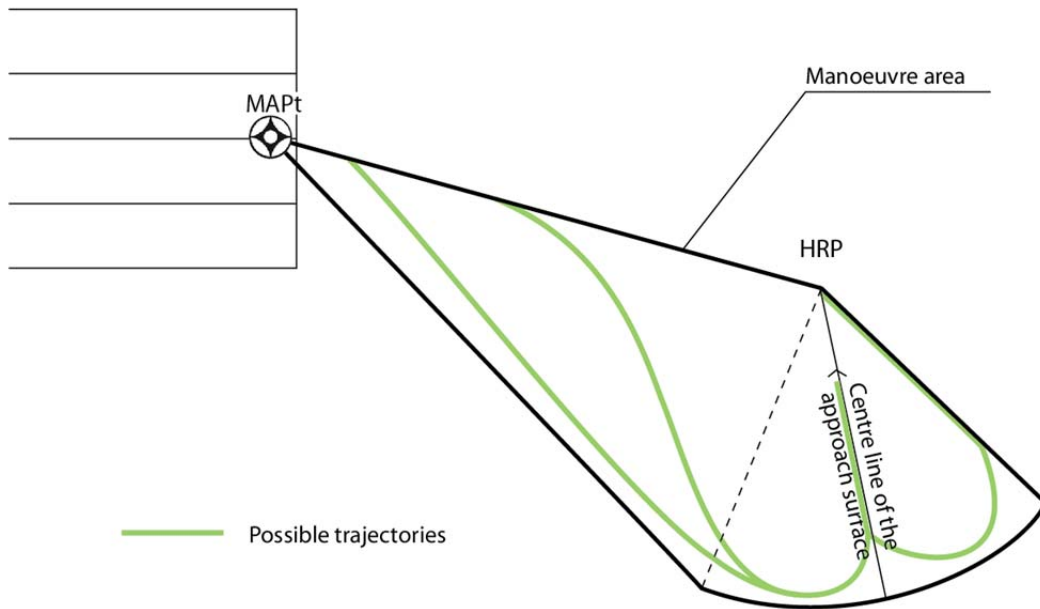
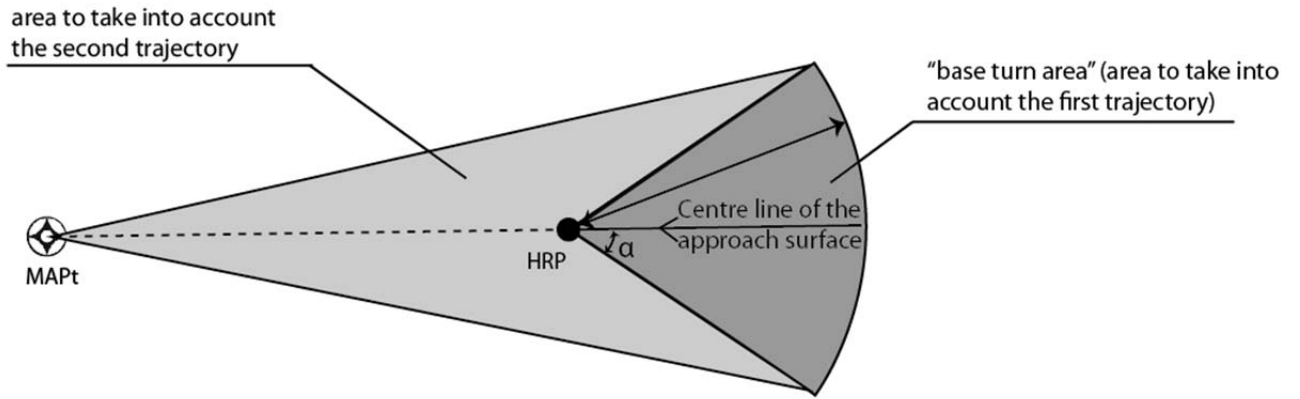
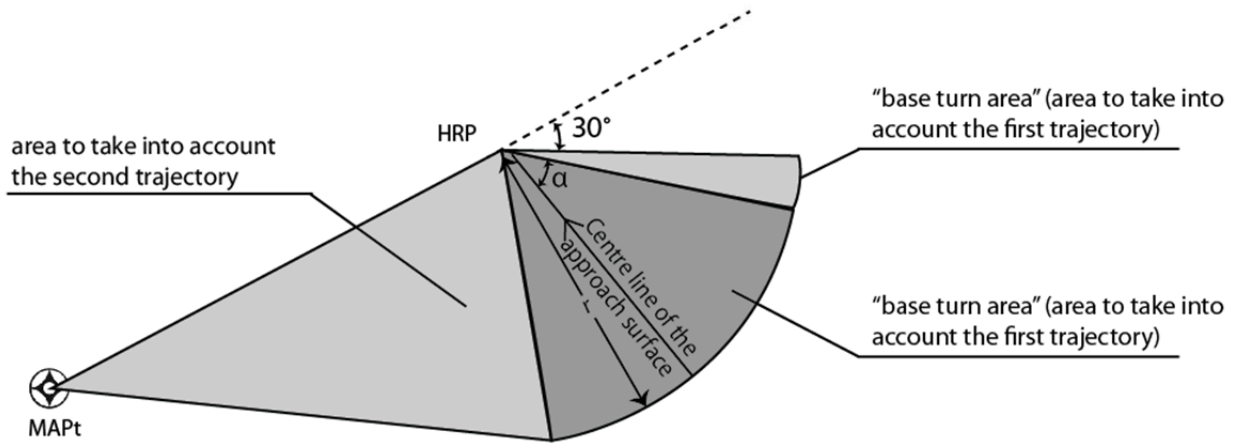

Figure IV-2-10. Representation of the possible trajectories defining the “Manoeuvre area”



a) "Base turn area" on both side of MAPt-HRP line



b) "Base turn area" on one side of MAPt-HRP line

Figure IV-2-11. Different types of "Manoeuvre Areas" depending on the defined approach surface

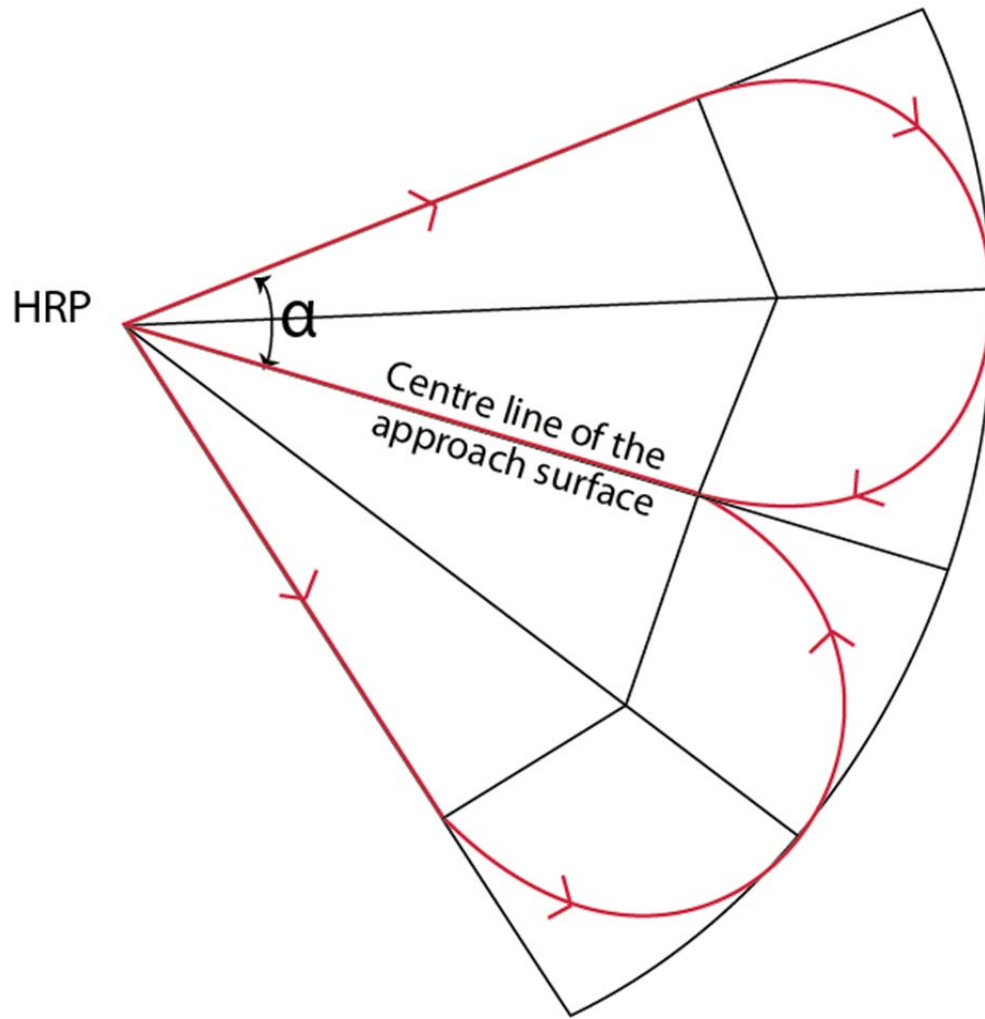

Figure IV-2-12. "Base turn area"

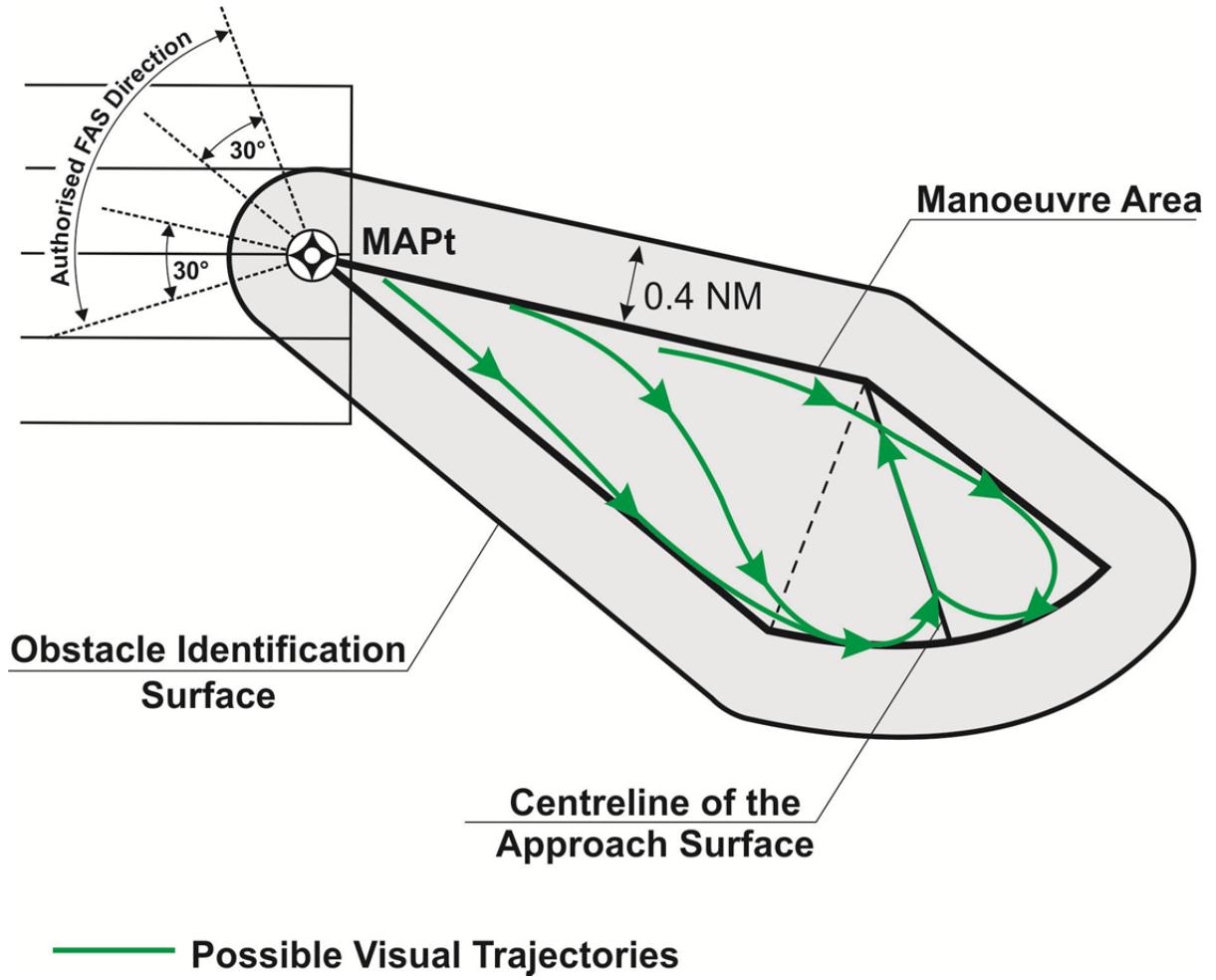
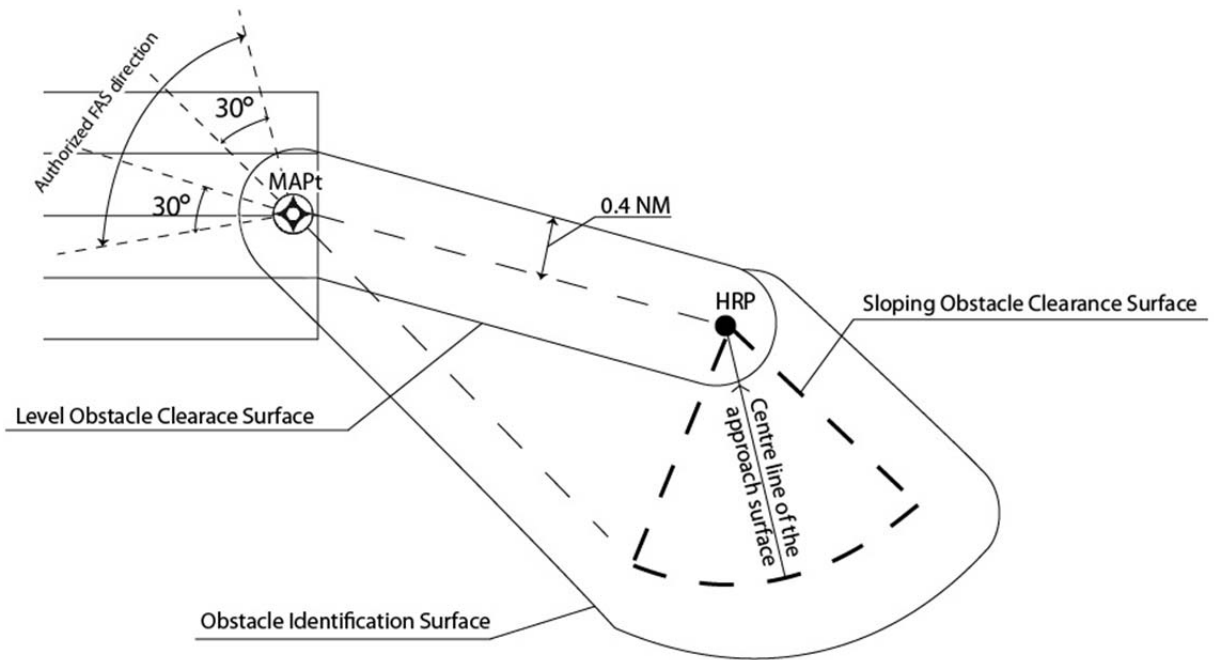
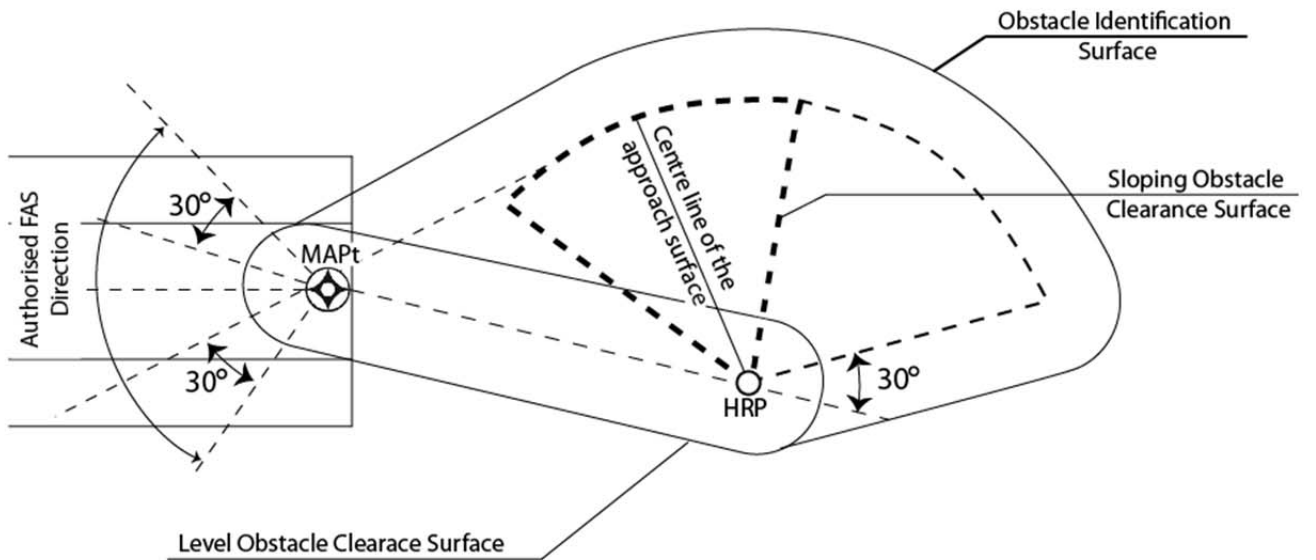

Figure IV-2-13. Representation of the level OIS for a defined approach surface



a) First example



b) Second example

Figure IV-2-14. Representation of the level OIS and level OCS based on two different approach surfaces

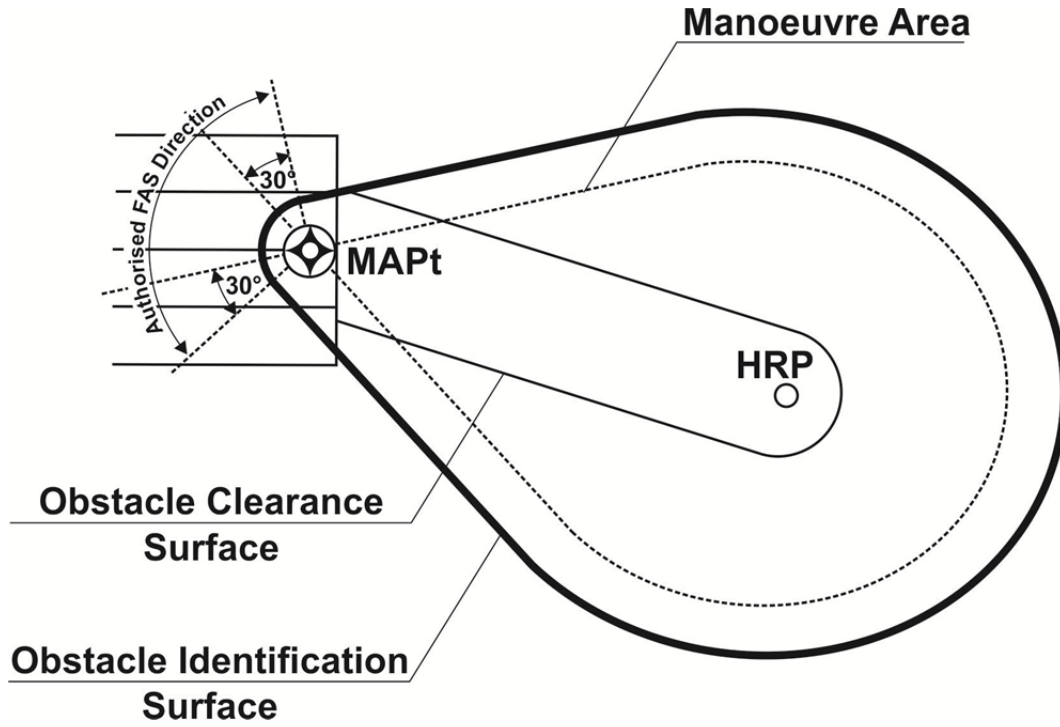
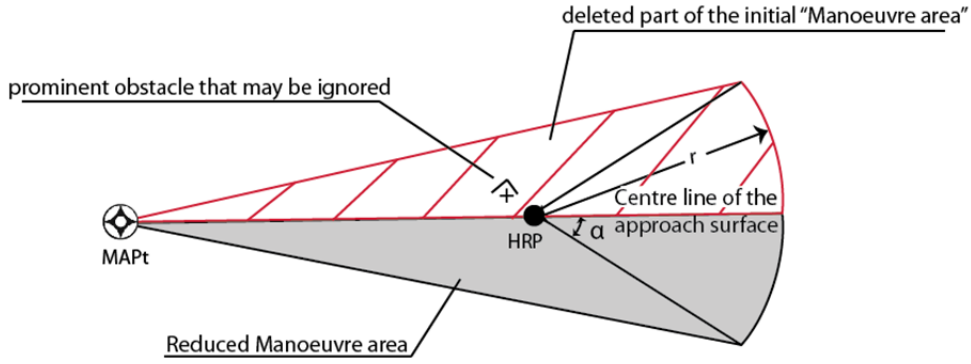
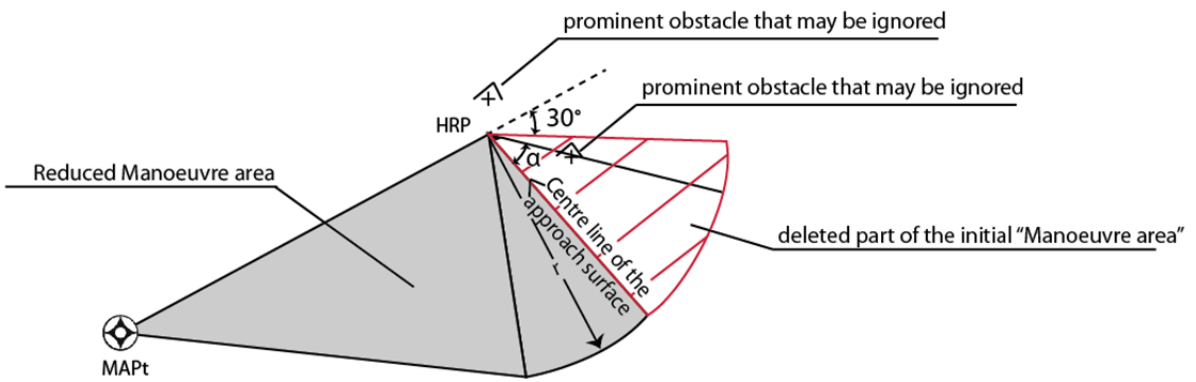

Figure IV-2-15. Representation of the level OIS and level OCS with "omni-directional" approach surfaces considered



a) Reduction of the Manoeuvre area due to a prominent obstacle (first example)



b) Reduction of the Manoeuvre area due to a prominent obstacle (second example)

Figure IV-2-16. Method for reducing OCA/H: Reduction of the "Manoeuvre area"

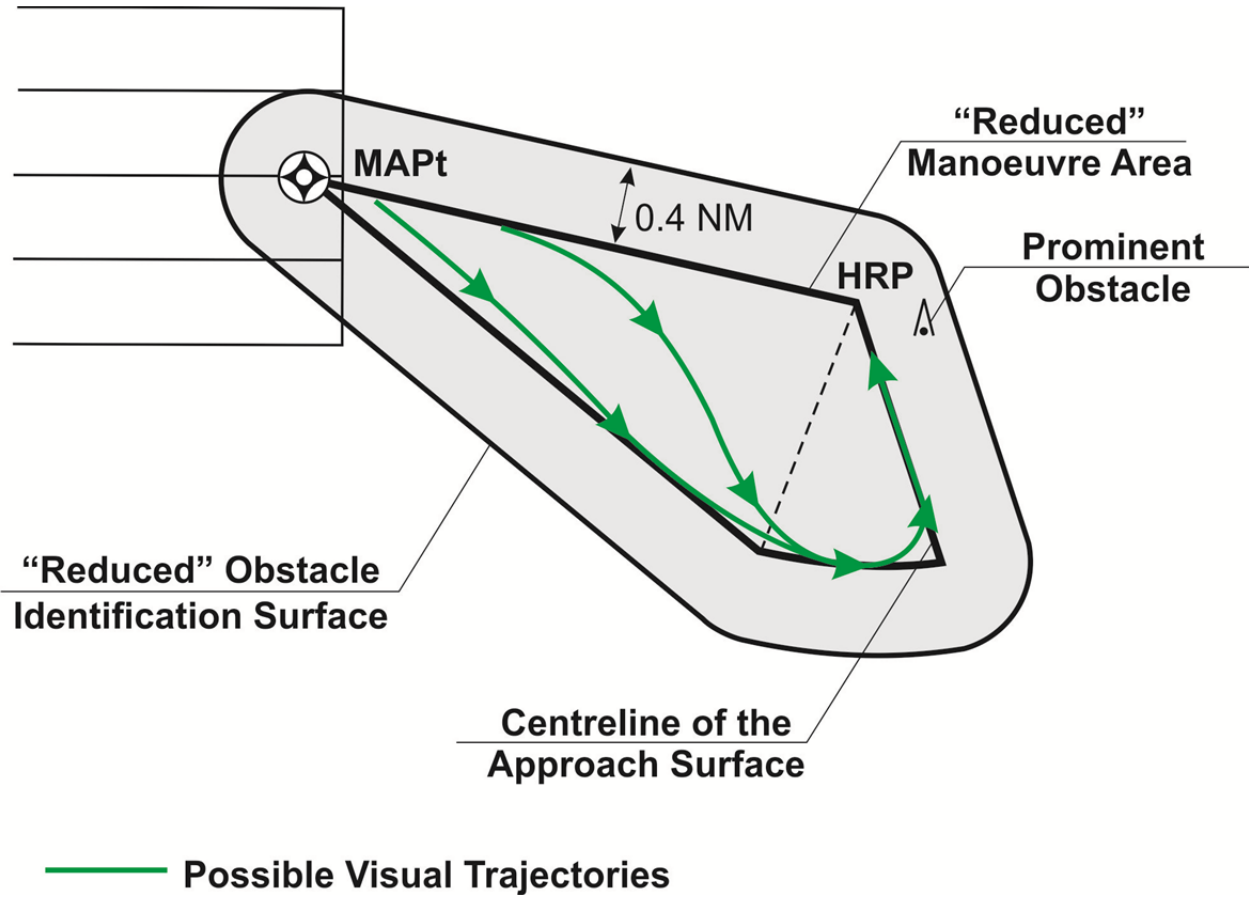

Figure IV-2-17. Method for reducing OCA/H: Reduced “Manoeuvre area” and level OIS

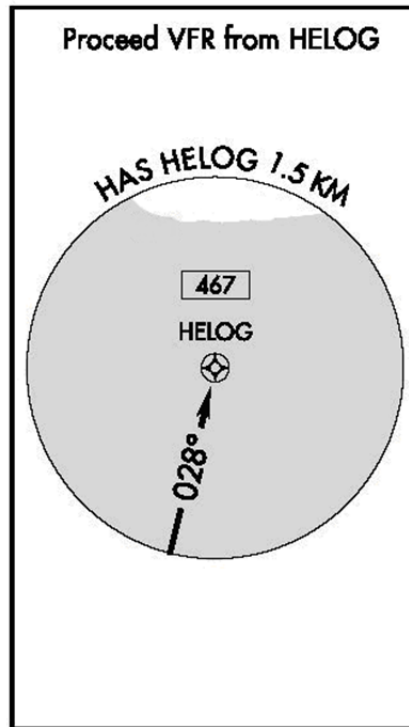

Figure IV-2-18. HAS diagram (showing both water and land surfaces) for PinS approach procedure with a “Proceed VFR” instruction

End of new figures.

Editorial note.— Insert a new Chapter 3 and Appendix as follows:

Chapter 3
POINT-IN-SPACE (PinS) RNP APCH APPROACH PROCEDURES
FOR HELICOPTERS DOWN TO LPV MINIMA

3.1 GENERAL

3.1.1 The general criteria in Part III, Section III, Chapter 5 and Part IV, Chapter 2, as amplified or modified by the criteria in this chapter, apply to PinS RNP APCH approaches for helicopters down to LPV minima.

3.2 FINAL APPROACH SEGMENT (FAS)

3.2.1 *FHP (fictitious heliport point) and PinS locations.* The final approach segment, ending at the PinS, is oriented on a FHP (fictitious heliport point). The FHP elevation is equal to the elevation of the landing heliport. The distance between the PinS and the FHP is equal to 800 m. This is illustrated in Figure IV-3-1.

Note.— Where the requirement that the FHP elevation be equal to the landing heliport elevation restricts the flexibility in design to an unacceptable level, another reference point may be used. Attention should be given to ensure that obstacles and OAS are based on the appropriate reference point.

3.2.2 *Definition of the FAS data block parameters.* Possible encoding for the FAS data block fields for PinS SBAS APV procedures is described in the Appendix. The following values are fixed:

- a) the distance between the GARP and the FHP is equal to 3000 m;
- b) the FHP course width is equal to +/- 105 m.

3.2.3 *Definition of an operational FAS.* Once the PinS and the FHP locations have been defined, an operational FAS can be defined. The following assumption is used: the OCA/H of the precision segment (OCA/Hps) is equal to the altitude/height of the nominal glide path at the PinS location. Based on this assumption, the operational FAS is defined by fixing two of the following three values: the Glide Path Angle (GPA), the OCA/Hps at the PinS and the crossing height of the flight path angle above the FHP (FHPCH). The following constraints apply for those values:

- a) $GPA \leq 6.3^\circ$ (11%)
- b) $OCHps \geq 250$ ft
- c) $FHPCH \geq 0$

Note.— Height values are above the heliport or landing location elevation.

3.2.4 *Validation of the chosen operational FAS.* Once the operational FAS has been defined, the general protection criteria described in Part III, Section III, Chapter 5 shall be applied. The system of coordinates used to express protection surfaces shall be based on the FHP location. General protection criteria shall be applied using Cat H parameters. However, because the OCA/Hps is geometrically fixed by the operational FAS, the following iterative process shall be performed to achieve the most efficient procedure, through application/determination of the lowest possible OCH and the lowest acceptable GPA:

- a) if there is no penetration of the protection surfaces, the defined operational FAS is acceptable. However, if the FAS is not the most efficient, a different FAS may be defined (for instance by decreasing the OCA/Hps and FAF elevation or by keeping the same FAF elevation and increasing the GP) and the obstacle protection surfaces shall be checked to determine if lower minima can be achieved;
- b) if there is a penetration of the protection surfaces, the defined FAS is not acceptable. In this case, a new operational FAS shall be defined (for instance by increasing both the OCA/Hps and FAF elevation or by keeping the same FAF elevation and decreasing the GP) and the new protection surfaces shall be checked.

3.3 VISUAL SEGMENT: ADJUSTMENT OF THE OCA/H AND PROTECTION

3.3.1 *Adjustment of the OCA/H.* In order to ensure adequate transition between the instrument phase of flight and the visual phase of flight, the final OCA/H is calculated by including an “add-on” value to the OCA/Hps defined in paragraph 3.2.3 and 3.2.4. This “add-on” value is directly linked to the GPA and is calculated by using the following formula:

$$\text{“add-on” value (ft)} = (1460/102) * \text{GPA (degree)}$$

The results of the calculation for a set of GPA values are detailed in table IV-3-1.

Table IV-3-1. “Add-on” for a set of GPA value

GPA	Add-on value (ft)	Add-on value (m)
3°	43	13.1
3.5°	50	15.3
4°	57	17.5
5°	72	21.9
6°	86	26.2

3.3.2 *Protection of the visual segment.* Criteria used for the definition and the protection of the visual segment described in paragraph 2.9 apply. However, where the OCA/H is used for the design of the LNAV procedure, it shall be replaced by the OCA/Hps value defined in paragraph 3.2.4. Similarly, where MDA/H value is used in paragraph 2.9, it shall be replaced by the (DA/H – “add-on”) value.

3.4 SUPPORTING PINS RNP APCH WITH LNAV MINIMA

When LNAV and LPV minima for a PinS RNP APCH procedure are depicted on the same chart, the PinS and GPA of the two approaches shall be the same. The LNAV GPA shall equal the LPV GPA and shall not be calculated in accordance with paragraph 2.7.5. As per definition, the LPV OCA/Hps shall be reached at the PinS location and the LNAV OCA/H shall be reached before the PinS.

3.5 MISSED APPROACH

The missed approach turn shall be prescribed at a designated Turning Point (TP) (See Part III, Section III, Chapter 5).

Note.— Currently criteria for turns at a designated altitude/height or “as soon as practicable” are not defined but are under development. Such criteria may be necessary in some locations, due to specific obstacle limitations, to optimize the LPV minima.

3.6 PROMULGATION

3.6.1 PinS approaches to LPV minima shall be promulgated in accordance with Volume II, Part III, Section 5, Chapter 1 and Volume II, Part IV, Chapter 2, paragraph 2.11.

3.6.2 A vertical profile inset shall be charted for these procedures. Information depicted in the vertical profile inset shall include the:

- a) LNAV visual segment profile;
- b) APV visual segment profile;
- c) heliport or landing location;
- d) location of the MAPt;
- e) final portion of the LNAV final approach segment;
- f) final portion of the APV final approach segment;
- g) heliport elevation;
- h) HCH;
- i) range scale originating from the MAPt to the heliport, which is also used to identify the DP, if one exists in the visual segment;
- j) visual segment track; and
- k) necessary notes needed to highlight certain attributes of the visual segment profiles.

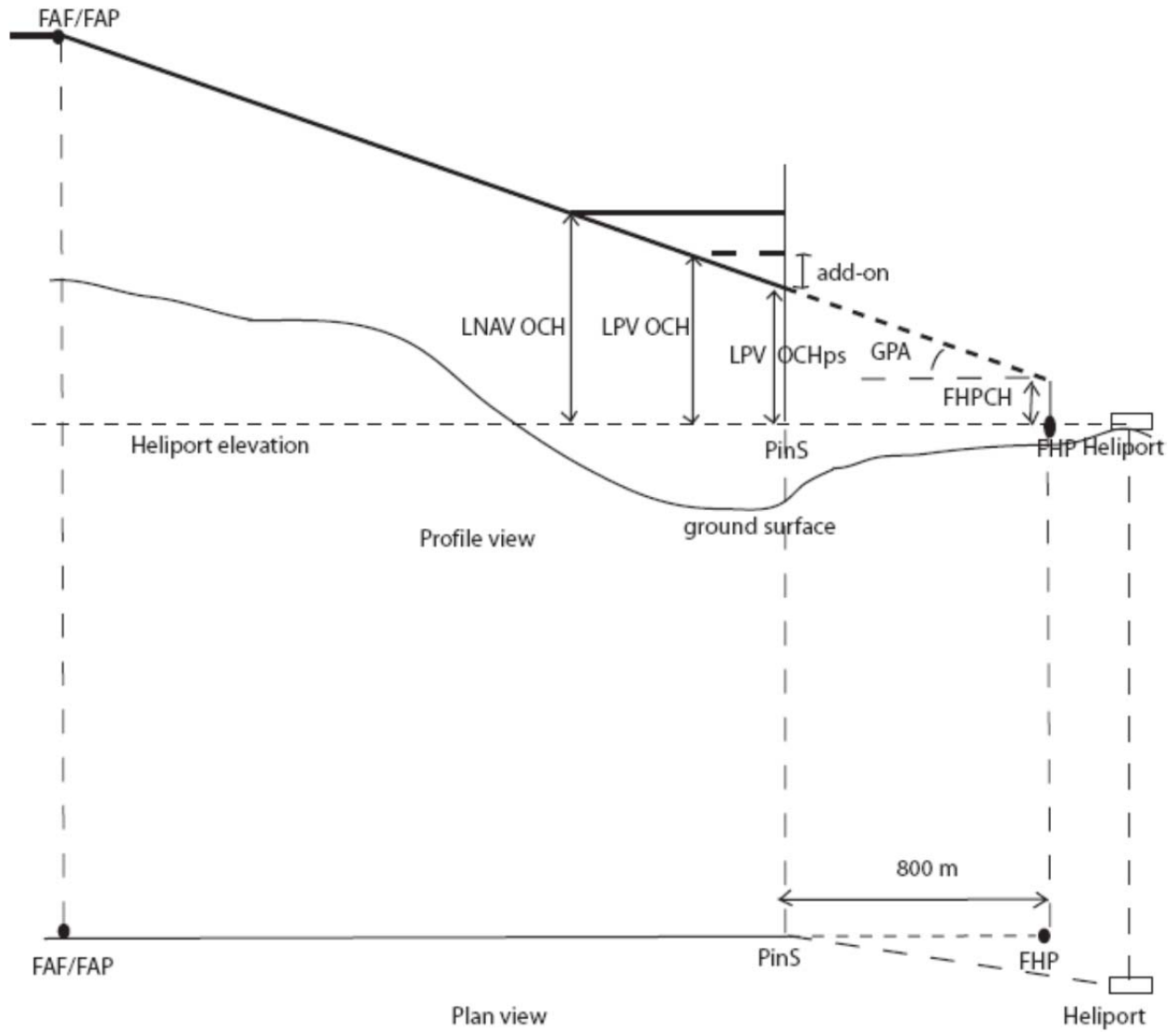

Figure IV-3-1. Representation of a PinS RNP APCH supporting LNAV and LPV minima

Appendix to Chapter 3
ENCODING OF THE SBAS HELICOPTER PINS FAS DATA BLOCK
AND DISPLAY SCALING

FAS Data Block Applications to PinS Procedures. The encoding of the FAS data block fields for PinS operations is based on Vol. II Part III Section 2 Chapter 6 Appendix A and should be encoded as described below:

- a) *Operation type*: 0 is reserved for straight-in or PinS procedures.
- b) *Service provider identifier*: 0 for WAAS, 1 for EGNOS, 2 for MSAS. A service provider ID of 15 indicates that any service provider may be used and a service provider ID of 14 indicates the FAS data block is not intended for SBAS use.
- c) *Airport identifier*: If the heliport has an identifier, it is encoded. If the heliport does not have an identifier, the procedure MAPt waypoint name, truncated to a maximum of four characters, should be used, since it is the closest described point in the procedure database to the heliport. For procedures serving multiple heliports, the procedure MAPt waypoint name should be used.
- d) *Runway number*: Runway number is interpreted as the final approach course rounded to the nearest 10 degrees (2 digits).
- e) *Runway letter*: Since there is not a letter associated with the procedure, the field is encoded as 00.
- f) *Approach performance designator*: The approach performance designator field is intended for the use by GBAS equipment and not used for SBAS operations.
- g) *Route indicator*: Encode the same as in Vol. II, Part III, Section 2, Chapter 6 Appendix A.
- h) *Reference path data selector (RPDS)*: A numerical identifier used to select the FAS data block (desired approach). It is intended for GBAS and is not used for SBAS operations.
- i) *Reference path identifier*: Since these procedures are not flown to runways, the two-digit runway number is replaced with the FAS track rounded to the closest 10 degrees.

Note.— This coding is consistent with a PinS procedure that supports approaches to more than one landing site.

- j) *Landing threshold point (LTP) / fictitious threshold point (FTP)-latitude*: Encode the heliport/fictitious heliport (HP/FHP) latitude the same as the LTP/FTP is encoded in Vol. II, Part III, Section 2, Chapter 6 Appendix A.
- k) *Landing threshold point (LTP) / fictitious threshold point (FTP)-longitude*: Encode the HP/FHP longitude the same as the LTP/FTP is encoded in Vol. II, Part III, Section 2, Chapter 6 Appendix A.
- l) *LTP/FTP height above ellipsoid (HAE)*: Encode the HP/FHP height above ellipsoid the same as the LTP/FTP HAE is encoded in Volume II, Part III, Section 2, Chapter 6, Appendix A.

- m) *Δ flight path alignment point (FPAP)-latitude*: This is the Δ latitude of a point located on a geodesic line beyond the HP/FHP that is aligned with the PinS FAS. Encode the same as in Volume II, Part III, Section 2, Chapter 6 Appendix A.
- n) *Δ flight path alignment point (FPAP)-longitude*. This is the Δ longitude of a point located on a geodesic line beyond the HP/FHP that is aligned with the PinS FAS. Encode the same as in Volume II, Part III, Section 2, Chapter 6, Appendix A.
- o) *Threshold crossing height (TCH)*: The designated crossing height of the flight path angle above the heliport/fictitious heliport (FHPCH). Encode the same as in Volume II, Part III, Section 2, Chapter 6, Appendix A.
- p) *TCH units selector*: Encode the same as depicted in Volume II, Part III, Section 2, Chapter 6, Appendix A.
- q) *Glidepath angle*: Encode the same as shown in Volume II, Part III, Section 2, Chapter 6, Appendix A.
- r) *Course width at threshold*: This is replaced with the course width at the heliport/fictitious heliport. For SBAS APV PinS approaches the FHP course width is equal to +/- 105 m
- s) *Δ length offset*: Since there is not a runway associated with the procedure, the field is encoded with a 0.
- t) *Horizontal alert limit (HAL)*: Encode as shown in Volume II, Part III, Section 2, Chapter 6, Appendix A. PinS procedures have HAL=40.
- u) *Vertical alert limit (VAL)*: For PinS procedures with lateral only guidance, VAL=0. When vertical guidance is provided, $VAL \leq 50$
- v) *Final approach segment CRC remainder*: Calculate and encode as shown in Volume II, Part III, Section 2, Chapter 6, Appendix A.

Display Scaling and Fictitious Heliport Orientation. Figure A-1 depicts the fictitious heliport orientation and display scaling that flight testing has demonstrated to be satisfactory. At the FHP, the lateral course width is +/-105 m. With the 3000 m distance between the FHP and GARP, the resulting angular splay is 2° . Extensive flight testing has demonstrated the best combination of procedure flyability and obstacle protection requirements results in a distance of 800 m between the PinS/MAPt and the FHP with a lateral course width of +/- 133 m at the PinS/MAPt location. The extreme flexibility in the application of the FAS data block to PinS procedures is noted.

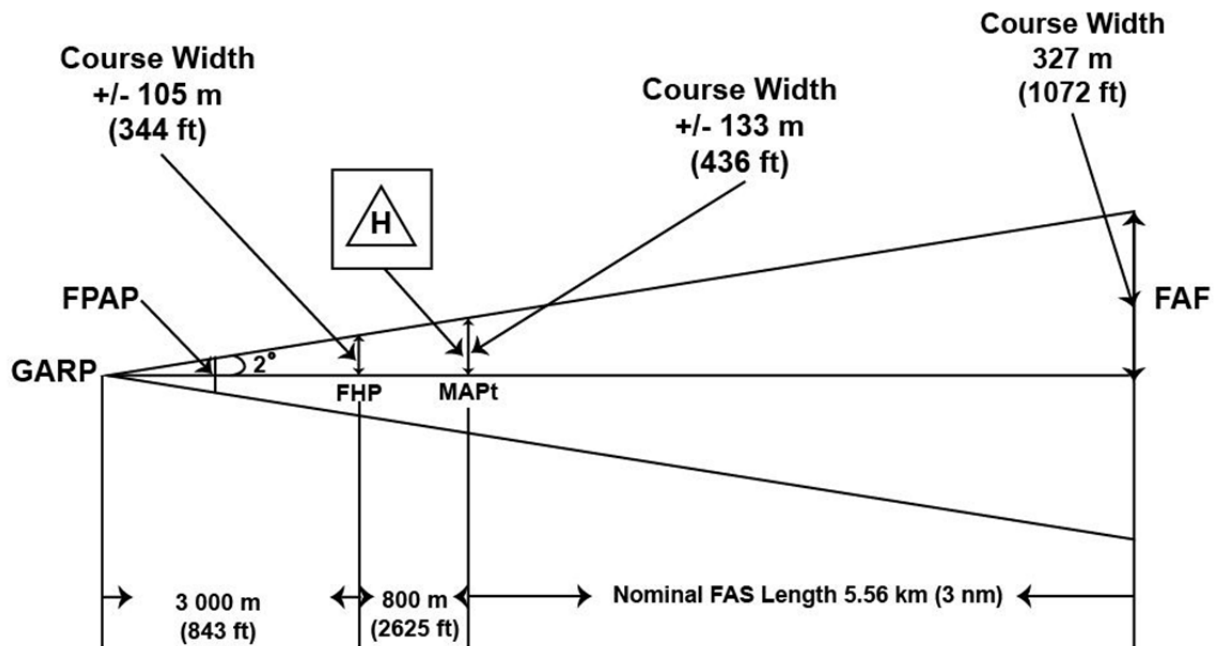

Figure A-1. Fictitious heliport orientation and lateral display scaling

Figure A-2 depicts the vertical display scaling and the scaling relationship to the fictitious heliport. Vertical display scaling includes the option of linear scaling once angular scaling becomes greater than ± 150 m or smaller than 15 m. The location along the vertical path where the optional linearization of display begins is a function of the glidepath angle angular splay ($\text{glidepath angle}/4^\circ$) where the full scale width is less than or equal to ± 15 m, or greater than or equal to 150 m. The FHP and the glide path intercept point (GPIP) lay in the same plane. The horizontal distance from the FHP to the PinS/MAPt location is maintained at 800 m regardless of the glide path angle to provide for proper lateral display scaling requirements.

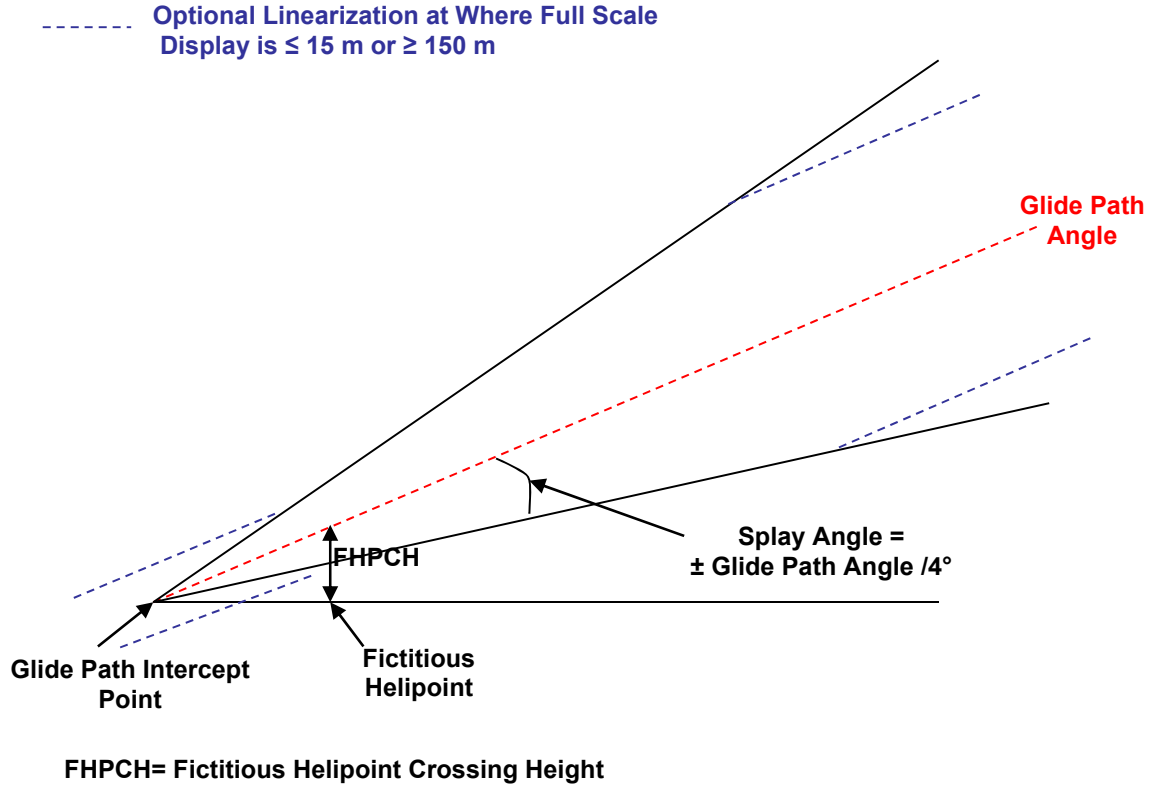

Figure A-2. Fictitious heliport orientation and vertical display scaling

End of new text.

<p><i>Origin:</i> IFPP / Secretariat</p>	<p><i>Rationale</i></p> <p>Current helicopter instrument procedure design criteria do not incorporate the use of vertical guidance that is available today through space-based systems nor does it allow for the design of instrument departures to re-join the IFR en route structure. This amendment addresses both of these deficiencies.</p> <p>This new criteria will allow for more effective arrivals and departures by helicopters to/from heliports and landing locations using the PinS concept and hence improve overall safety and efficiency of helicopter operations</p>
--	--

ATTACHMENT D to State letter SP 65/4-13/24

PROPOSED AMENDMENT TO ANNEX 4

NOTES ON THE PRESENTATION OF THE AMENDMENT

1. The text of the amendment is arranged to show deleted text with a line through it and new text highlighted with grey shading, as shown below:

~~Text to be deleted is shown with a line through it.~~

text to be deleted

New text to be inserted is highlighted with grey shading.

new text to be inserted

~~Text to be deleted is shown with a line through it~~ followed by the replacement text which is highlighted with grey shading.

new text to replace existing text

**PROPOSED AMENDMENT TO
INTERNATIONAL STANDARDS
AND RECOMMENDED PRACTICES**

AERONAUTICAL CHARTS

ANNEX 4

TO THE CONVENTION ON INTERNATIONAL AVIATION

...

HELICOPTERS

CHAPTER 1. DEFINITIONS, APPLICABILITY AND AVAILABILITY

1.1 Definitions

...

Heliport reference point (HRP). The designated location of a heliport or a landing location.

...

Minimum sector altitude (MSA). The lowest altitude which may be used which will provide a minimum clearance of 300 m (1 000 ft) above all objects located in an area contained within a sector of a circle of 46 km (25 NM) radius centred on a ~~radio aid to navigation~~ significant point, the aerodrome reference point (ARP), or the heliport reference point (HRP).

...

CHAPTER 11. INSTRUMENT APPROACH CHART — ICAO

...

11.10.6 Portrayal of procedure tracks

...

11.10.6.3 A profile shall be provided normally below the plan view showing the following data:

...

- f) altitudes/heights required by the procedures, including transition altitude ~~and~~, procedure altitudes/heights, ~~and~~ heliport crossing height (HCH) where established;

...

APPENDIX 6. AERONAUTICAL DATA QUALITY REQUIREMENTS

...

Table 2. Elevation/altitude/height

Elevation/altitude/height	Chart resolution	Integrity / Classification
...		
Heliport crossing height, PinS approaches	1 m or 1 ft	essential

<p><i>Origin:</i> <i>IFPP / Secretariat</i></p>	<p><i>Rationale</i></p> <p>Current helicopter instrument procedure design criteria do not incorporate the use of vertical guidance that is available today through space-based systems nor does it allow for the design of instrument departures to re-join the IFR en route structure. This amendment addresses both of these deficiencies.</p> <p>This new criteria will allow for more effective arrivals and departures by helicopters to/from heliports and landing locations using the PinS concept and hence improve overall safety and efficiency of helicopter operations</p> <p>The proposed changes Annex 4 are consequential to PANS-OPS Vol II necessitating revisions to definitions, the charting depiction of PinS procedures, and aeronautical data quality requirements.</p>
---	--

ATTACHMENT E to State letter SP 65/4-13/24

PROPOSED AMENDMENT TO ANNEX 6

NOTES ON THE PRESENTATION OF THE AMENDMENT

1. The text of the amendment is arranged to show deleted text with a line through it and new text highlighted with grey shading, as shown below:

~~Text to be deleted is shown with a line through it.~~

text to be deleted

New text to be inserted is highlighted with grey shading.

new text to be inserted

~~Text to be deleted is shown with a line through it~~ followed by the replacement text which is highlighted with grey shading.

new text to replace existing text

**PROPOSED AMENDMENT TO
INTERNATIONAL STANDARDS
AND RECOMMENDED PRACTICES**

OPERATION OF AIRCRAFT

**ANNEX 6
TO THE CONVENTION ON INTERNATIONAL AVIATION**

PBN — CHARTING

**PART I
INTERNATIONAL COMMERCIAL AIR TRANSPORT — AEROPLANES**

...

CHAPTER 9. AEROPLANE FLIGHT CREW

...

9.3 Flight crew member training programmes

9.3.1 An operator shall establish and maintain a ground and flight training programme, approved by the State of the Operator, which ensures that all flight crew members are adequately trained to perform their assigned duties. The training programme shall:

...

- d) include training in knowledge and skills related to visual and instrument flight procedures for the intended area of operation, charting, human performance including threat and error management and in the transport of dangerous goods;

...

<i>Origin:</i> <i>IFPP / Secretariat</i>	<i>Rationale</i> Inconsistencies with the charts, the PBN approvals and avionics displays have created confusion. The rationalization of procedure identification detailed in this amendment addresses the issue and provides a simpler and clearer method for procedure naming and a standardized approach to charting. With the advent of PBN and the changes in how procedures are charted, Flight crew training is required.
---	---

REGULATORY REQUIREMENTS

**PART I
INTERNATIONAL COMMERCIAL AIR TRANSPORT — AEROPLANES**

...

CHAPTER 4. FLIGHT OPERATIONS

...

4.4.8 Instrument flight procedures

...

4.4.8.2 All aeroplanes operated in accordance with instrument flight rules shall comply with the instrument flight procedures approved by the State in which the aerodrome is located.

Note 1.— Definitions for the classification of instrument approach and landing operations are in Chapter 1.

Note 2.— Operational procedures recommended for the guidance of operations personnel involved in instrument flight operations are described in PANS-OPS (Doc 8168), Volume I.

Note 3.— Criteria for the construction of instrument flight procedures for the guidance of procedure specialists are provided in PANS-OPS (Doc 8168), Volume II. Obstacle clearance criteria and procedures used in certain States may differ from PANS-OPS, and knowledge of these differences is important for safety reasons (see Chapter 3, 3.1.1).

...

**PART II
INTERNATIONAL GENERAL AVIATION — AEROPLANES**

...

**SECTION 2
GENERAL AVIATION OPERATIONS**

...

2.2.4 In-flight procedures

...

2.2.4.7 Instrument approach procedures

...

2.2.4.7.2 Aeroplanes operated in accordance with the instrument flight rules shall comply with the instrument approach procedures approved by the State in which the aerodrome is located.

Note 1.— Definitions for the classification of instrument approach and landing operations are in Chapter 1.1.

Note 2.— Information for pilots on flight procedure parameters and operational procedures is contained in PANS-OPS, Volume I. Criteria for the construction of visual and instrument flight procedures are contained in PANS-OPS, Volume II. Obstacle clearance criteria and procedures used in certain States may differ from PANS-OPS, and knowledge of these differences is important for safety reasons (see Chapter 2.1, 2.1.1.1).

...

**PART III
INTERNATIONAL OPERATIONS — HELICOPTERS**

...

SECTION II. INTERNATIONAL COMMERCIAL AIR TRANSPORT

...

CHAPTER 2. FLIGHT OPERATIONS

...

2.4 In-flight procedures

...

2.4.7 Instrument flight procedures

...

2.4.7.2 All helicopters operated in accordance with IFR shall comply with the instrument approach procedures approved by the State in which the heliport is located, or by the State which is responsible for the heliport when located outside the territory of any State.

Note 1.— Operational procedures recommended for the guidance of operations personnel involved in instrument flight operations are described in PANS-OPS (Doc 8168), Volume I.

Note 2.— Criteria for the construction of instrument flight procedures for the guidance of procedure specialists are provided in PANS-OPS (Doc 8168), Volume II. Obstacle clearance criteria and procedures used in certain States may differ from PANS-OPS, and knowledge of these differences is important for safety reasons (see Chapter 1, 1.1.1).

...

SECTION III. INTERNATIONAL GENERAL AVIATION

...

CHAPTER 2. FLIGHT OPERATIONS

...

2.16 Instrument flight procedures

...

2.16.2 All helicopters operated in accordance with IFR shall comply with the instrument approach procedures approved by the State in which the heliport is located, or by the State which is responsible for the heliport when located outside the territory of any State.

Note 1.— Operational procedures recommended for the guidance of operations personnel involved in instrument flight operations are described in PANS-OPS (Doc 8168), Volume I.

Note 2.— Criteria for the construction of instrument flight procedures for the guidance of procedure specialists are provided in PANS-OPS (Doc 8168), Volume II. Obstacle clearance criteria and procedures used in certain States may differ from PANS-OPS, and knowledge of these differences is important for safety reasons (see Chapter 1, 1.1.1).

...

<p><i>Origin:</i> <i>IFPP / Secretariat</i></p>	<p><i>Rationale</i></p> <p>Currently, there are no ICAO provisions at the Annex (SARPs) level, governing the responsibility of Contracting States for the provision of an instrument flight procedure design service. As a result, implementation of flight procedure design provision and oversight varies in scope, method and quality across the world. This amendment is consequential to Annex 11.</p>
---	---

ATTACHMENT F to State letter SP 65/4-13/24

PROPOSED AMENDMENT TO ANNEX 14, VOLUME II

NOTES ON THE PRESENTATION OF THE AMENDMENT

1. The text of the amendment is arranged to show deleted text with a line through it and new text highlighted with grey shading, as shown below:

~~Text to be deleted is shown with a line through it.~~

text to be deleted

New text to be inserted is highlighted with grey shading.

new text to be inserted

~~Text to be deleted is shown with a line through it~~ followed by the replacement text which is highlighted with grey shading.

new text to replace existing text

**PROPOSED AMENDMENT TO
INTERNATIONAL STANDARDS
AND RECOMMENDED PRACTICES**

AERODROMES

ANNEX 14

VOLUME II — HELIPORTS

TO THE CONVENTION ON INTERNATIONAL AVIATION

...

HELICOPTERS

CHAPTER 1. GENERAL

...

1.1 Definitions

...

Helicopter reference point (HRP). The designated location of a helicopter or a landing location.

...

Landing location. A marked or unmarked landing area that has the same physical characteristics as a visual helicopter final approach and take-off area (FATO).

...

CHAPTER 2. HELIPORT DATA

...

2.2 Helicopter reference point

2.2.1 A helicopter reference point shall be established for a helicopter or a landing location not collocated with an aerodrome.

Note.— When the helicopter is collocated with an aerodrome, the established aerodrome reference point serves both aerodrome and helicopter.

2.2.2 The helicopter reference point shall be located near the initial or planned geometric centre of the helicopter or landing location and shall normally remain where first established.

...

APPENDIX 1. AERONAUTICAL DATA QUALITY REQUIREMENTS

...

Table A1-2. Elevation/altitude/height

Elevation/altitude/height	Accuracy Data type	Integrity Classification
---------------------------	-----------------------	-----------------------------

...

Heliport crossing height, PinS approaches.....	0.5 m calculated	essential
--	---------------------	-----------

...

<p><i>Origin:</i> <i>IFPP / Secretariat</i></p>	<p><i>Rationale</i></p> <p>Current helicopter instrument procedure design criteria do not incorporate the use of vertical guidance that is available today through space-based systems nor does it allow for the design of instrument departures to re-join the IFR en route structure. This amendment addresses both of these deficiencies.</p> <p>This new criteria will allow for more effective arrivals and departures by helicopters to/from heliports and landing locations using the PinS concept and hence improve overall safety and efficiency of helicopter operations</p> <p>The proposed changes to Annex 14, Volume II are consequential to PANS-OPS, Volume II necessitating revisions to definitions, heliport data, and aeronautical data quality requirements.</p>
---	---

ATTACHMENT G to State letter SP 65/4-13/24

PROPOSED AMENDMENT TO ANNEX 15

NOTES ON THE PRESENTATION OF THE AMENDMENT

1. The text of the amendment is arranged to show deleted text with a line through it and new text highlighted with grey shading, as shown below:

~~Text to be deleted is shown with a line through it.~~

text to be deleted

New text to be inserted is highlighted with grey shading.

new text to be inserted

~~Text to be deleted is shown with a line through it~~ followed by the replacement text which is highlighted with grey shading.

new text to replace existing text

**PROPOSED AMENDMENT TO
INTERNATIONAL STANDARDS
AND RECOMMENDED PRACTICES**

AERONAUTICAL INFORMATION SERVICES

ANNEX 15

TO THE CONVENTION ON INTERNATIONAL AVIATION

...

PBN — CHARTING

**APPENDIX 1. CONTENTS OF
AERONAUTICAL INFORMATION PUBLICATION (AIP)**

...

ENR 3.3 Area navigation routes

Detailed description of area navigation (RNAV) routes, including:

...

- 3) magnetic bearing to the nearest degree, geodesic distance to the nearest tenth of a kilometre or tenth of a nautical mile between defined end-points and distance between each successive designated significant point;

...

<i>Origin:</i> <i>IFPP / Secretariat</i>	<i>Rationale</i> This proposal concerns that there is no standard concerning the depiction of magnetic bearings on RNAV routes. This may result in a disparity between what is provided on the chart and what is displayed to pilots. This amendment will harmonize the charted and displayed magnetic directional values which can be expected upon rollout after passing a significant point on an RNAV route. This will improve situational awareness and provide a means to cross-check the airborne data.
---	---

PBN — SBAS/GBAS

****** AD 2.19 Radio navigation and landing aids**

Detailed description of radio navigation and landing aids associated with the instrument approach and the terminal area procedures at the aerodrome, including:

...

- 3) frequency(ies), channel number(s), service provider, and reference path identifier(s) (RPI), as appropriate;

...

- 6) elevation of the transmitting antenna of DME to the nearest 30 m (100 ft) and of DME/P to the nearest 3 m (10 ft) ~~and~~ elevation of GBAS reference point to the nearest metre or foot and the ellipsoid height of the point to the nearest metre or foot. For SBAS, the ellipsoid height of the landing threshold point (LTP) or the fictitious threshold point (FTP) to the nearest metre or foot;

- 7) service volume radius from the GBAS reference point to the nearest kilometre or nautical mile; and

~~7)~~8)remarks.

...

<p><i>Origin:</i> IFPP / Secretariat</p>	<p><i>Rationale</i></p> <p>Amendment 85 to ICAO Annex 10 introduced the SBAS signal in space performance requirements for Cat I precision approach operations. PANS-OPS has to be updated to reflect these improved performance requirements. Cat I SBAS approach operations will provide improved accessibility through lower minima.</p> <p>The Route Indicator (RI) field in the SBAS FAS data block encoding provides the same information as the ARINC Characteristic 424 Supplement 19 Multiple Approach Indicator which is synonymous with the Duplicate Procedure Indicator terminology already used in Doc 8168. This amendment standardizes the use of this indicator and, hence improves safety.</p> <p>This amendment also corrects the current information provided on encoding FAS data block.</p>
--	--

HELICOPTERS

APPENDIX 7. AERONAUTICAL DATA QUALITY REQUIREMENTS

...

Table A7-2. Elevation/altitude/height

Elevation/altitude/height	Publication resolution	Integrity Classification
...		
Heliport crossing height, PinS approaches.....	1 m or 1 ft	essential

<p><i>Origin:</i> IFPP / Secretariat</p>	<p><i>Rationale</i></p> <p>Current helicopter instrument procedure design criteria do not incorporate the use of vertical guidance that is available today through space-based systems nor does it allow for the design of instrument departures to re-join the IFR en route structure. This amendment addresses both of these deficiencies.</p> <p>This new criteria will allow for more effective arrivals and departures by helicopters to/from heliports and landing locations using the PinS concept and hence improve overall safety and efficiency of helicopter operations.</p> <p>The proposed changes to Annex 15 are consequential to PANS-OPS, Volume II necessitating revisions to aeronautical data quality requirements.</p>
--	---

ATTACHMENT H to State letter SP 65/4-13/24

PROPOSED AMENDMENT TO PANS-ABC

NOTES ON THE PRESENTATION OF THE AMENDMENT

1. The text of the amendment is arranged to show deleted text with a line through it and new text highlighted with grey shading, as shown below:

~~Text to be deleted is shown with a line through it.~~

text to be deleted

New text to be inserted is highlighted with grey shading.

new text to be inserted

~~Text to be deleted is shown with a line through it~~ followed by the replacement text which is highlighted with grey shading.

new text to replace existing text

**PROPOSED AMENDMENT TO
PROCEDURES FOR AIR NAVIGATION SERVICES
ICAO ABBREVIATIONS AND CODES**

HELICOPTERS

ABBREVIATIONS

DECODE

...

HCH Heliport crossing height

...

HRP Heliport reference point

...

ENCODE

...

Heliport crossing height HCH

Heliport reference point HRP

...

<i>Origin: IFPP / Secretariat</i>	<i>Rationale</i> Current helicopter instrument procedure design criteria do not incorporate the use of vertical guidance that is available today through space-based systems nor does it allow for the design of instrument departures to re-join the IFR en route structure. This amendment addresses both of these deficiencies. This new criteria will allow for more effective arrivals and departures by helicopters to/from heliports and landing locations using the PinS concept and hence improve overall safety and efficiency of helicopter operations. The proposed changes to PANS-ABC are consequential to PANS-OPS necessitating new abbreviations to support Helicopter PinS procedures. This consequential amendment to PANS-ABC addresses the new abbreviations.
---------------------------------------	---

EXECUTIVE SUMMARY
DESCRIPTION OF THE PROPOSED ICAO CIRCULAR ON THE
CONVERSION OF RNAV TO RNP APPROACH CHART DEPICTION (CIRC 336)

The purpose of the ICAO circular is to assist States and organizations with the conversion of area navigation (RNAV) approach procedure depiction to required navigation performance (RNP). This will align charts with the PBN navigation specifications (RNP APCH and RNP AR APCH), address flight planning requirements and simplify operations approvals.

While the actual change may seem minor or simplistic in nature, there are many areas that are impacted including changes to databases, charts, operations approvals, aircraft flight manual (AFM), electronic flight bags (EFBs), etc. Consequently, the circular identifies organizations that must be involved with the transition planning.

Because of the number of RNAV approach procedures that will be impacted, the circular recognizes that States cannot complete the change at one time and that a transition period is required. A timeframe of eight years has been established to allow States sufficient time to convert.

The circular will address the following:

- the reasoning for the charting change;
- the requirement for each State to have a transition plan that explains how the conversion will be completed including a timeline;
- the organizations that need to be consulted with in order to develop an acceptable transition plan;
- guidance on the organization and lay-out of the transition plan;
- identification of hazards, risks and mitigations that may be applicable to a State, and thus should be considered in the development of the transition plan;
- identification of training requirements;
- the importance of completing the transition as soon as possible in consultation with all Stakeholders. States should not delay implementation until 2022, but aim to have the conversion completed as soon as practicable;
- a communications strategy for States to follow that will assist them with conveying the change to all Stakeholders; and
- a recommendation that the State PBN Plan be updated with information on the conversion of RNAV approaches to RNP.

The circular is expected to be published in the fourth quarter of 2013. This will provide sufficient time for the preparation of State transition plans which would allow implementation to commence on 13 November 2014.

ATTACHMENT J to State letter SP 65/4-13/24

RESPONSE FORM TO BE COMPLETED AND RETURNED TO ICAO TOGETHER WITH ANY COMMENTS YOU MAY HAVE ON THE PROPOSED AMENDMENTS

To: The Secretary General
 International Civil Aviation Organization
 999 University Street
 Montréal, Quebec
 Canada, H3C 5H7

(State) _____

Please make a checkmark (✓) against one option for each amendment. If you choose options “agreement with comments” or “disagreement with comments”, **please provide your comments on separate sheets.**

	<i>Agreement without comments</i>	<i>Agreement with comments*</i>	<i>Disagreement without comments</i>	<i>Disagreement with comments</i>	<i>No position</i>
Amendment to Doc 8168, <i>Procedures for Air Navigation Services — Aircraft Operations</i> , Volume I — <i>Flight Procedures</i> (Attachment B refers)					
Amendment to Doc 8168, <i>Procedures for Air Navigation Services — Aircraft Operations</i> , Volume II — <i>Construction of Visual and Instrument Flight Procedures</i> (Attachment C refers)					
Amendment to Annex 4 — <i>Aeronautical Charts</i> (Attachment D refers)					
Amendment to Annex 6 — <i>Operation of Aircraft</i> (Attachment E refers)					
Amendment to Annex 14 — <i>Aerodromes</i> , Volume II — <i>Heliports</i> (Attachment F refers)					
Amendment to Annex 15 — <i>Aeronautical Information Services</i> (Attachment G refers)					
Amendment to PANS-ABC (Doc 8400), <i>Procedures for Air Navigation Services — ICAO Abbreviations and Codes</i> (Attachment H refers)					

*“Agreement with comments” indicates that your State or organization agrees with the intent and overall thrust of the amendment proposal; the comments themselves may include, as necessary, your reservations concerning certain parts of the proposal and/or offer an alternative proposal in this regard.

Signature: _____ Date: _____

— END —