



SUPPORTING
EUROPEAN
AVIATION

Understanding FF-ICE through scenarios

EUR/NAT FF-ICE Workshop

17 February 2026



NETWORK
MANAGER



Scenarios assumptions

- Airspace users are FF-ICE capable (eAU)
- Mixed mode – both eASPs and aASPs
- Submission procedures
 - Departure ASP is either FF-ICE capable or delegated distribution responsibility to AU

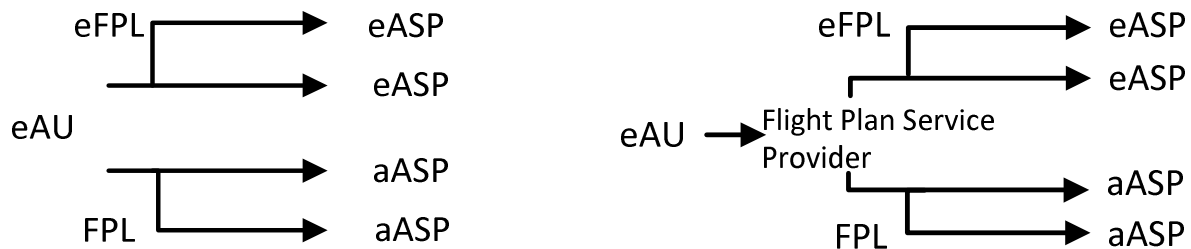

- Departure ASP is non FF-ICE capable and no distribution delegation to AU

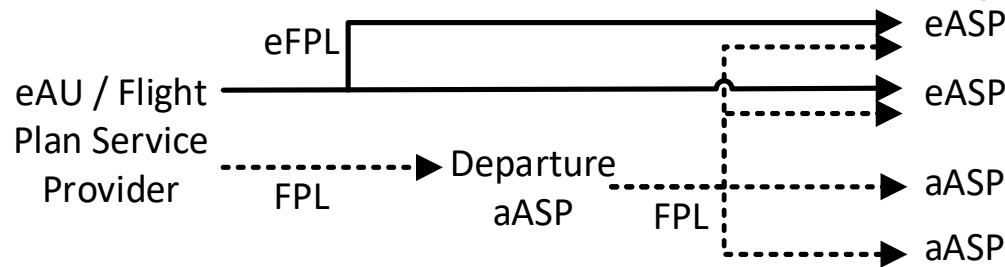

Scenarios description

Flight departing IFPZ and landing outside IFPZ			
	Routing	FF-ICE/R1 Services Involved	Other Features
S1-UC1	NM – aASP 1 – eASP B	<ul style="list-style-type: none"> • Trial Service • Filing Service • Notification Service 	<ul style="list-style-type: none"> • Re-evaluation Service
S1-UC2	NM – aASP 1 – eASP B	<ul style="list-style-type: none"> • Planning Service • Filing Service • Trial Service 	<ul style="list-style-type: none"> • Re-evaluation Service • Flight Plan Update

Flight departing outside IFPZ and landing inside IFPZ			
	Routing	FF-ICE/R1 Services Involved	Other Features
S2	aASP 1 – eASP B – NM	<ul style="list-style-type: none"> • Trial Service • Filing Service 	<ul style="list-style-type: none"> • Re-evaluation Service

S1-UC1 – Sequence diagram (1)

Flight departing IFPZ and landing outside IFPZ (NM – aASP 1 – eASP-B) / Trial, Filing and Notification

- **Trial Service:** eAU submits a trial request (TRQ) to verify flight plan validity before filing eFPL
eASP-B and **NM** respond with submission response “ACK” and trial response (TRS) CONCUR

- **Filing Service:** eAU submits eFPL with traj from TRQ to all eASPs and FPL to the **aASP1**

eASP-B responds with Submission Response (SR) “ACK” and Filing Status (FS) “PENDING”; **NM** responds with SR “ACK” + FS: ACCEPTABLE including the Agreed 4DT

Later-on **eASP-B** provides the FS ACCEPTABLE including the Agreed 4DT

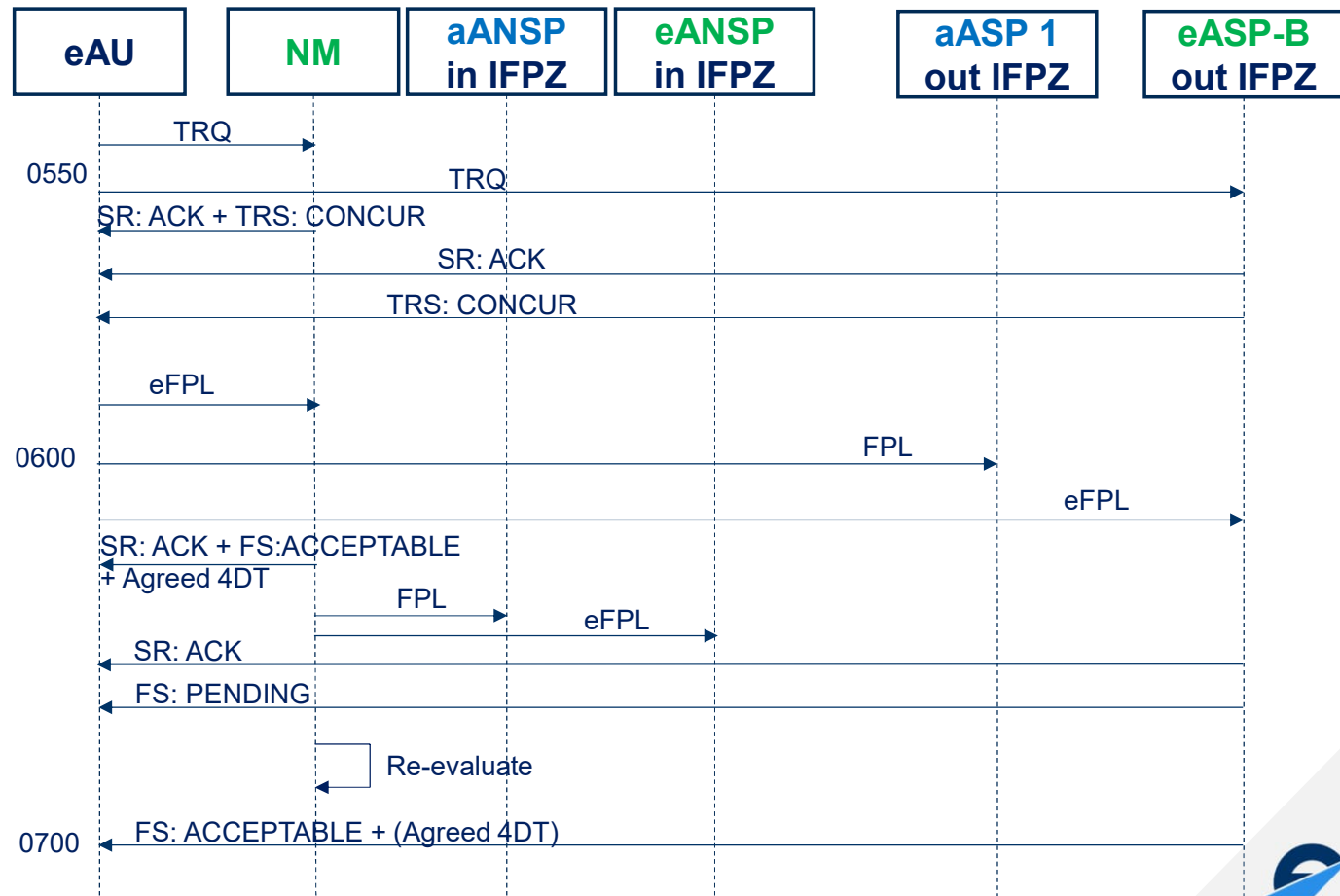

S1-UC1 – Sequence diagram (2)

Flight departing IFPZ and landing outside IFPZ (NM – aASP 1 – eASP-B) / Trial, Filing and Notification

- Notification Service:**
Departure notification is sent upon departure

eASP-B responds with SR "ACK"

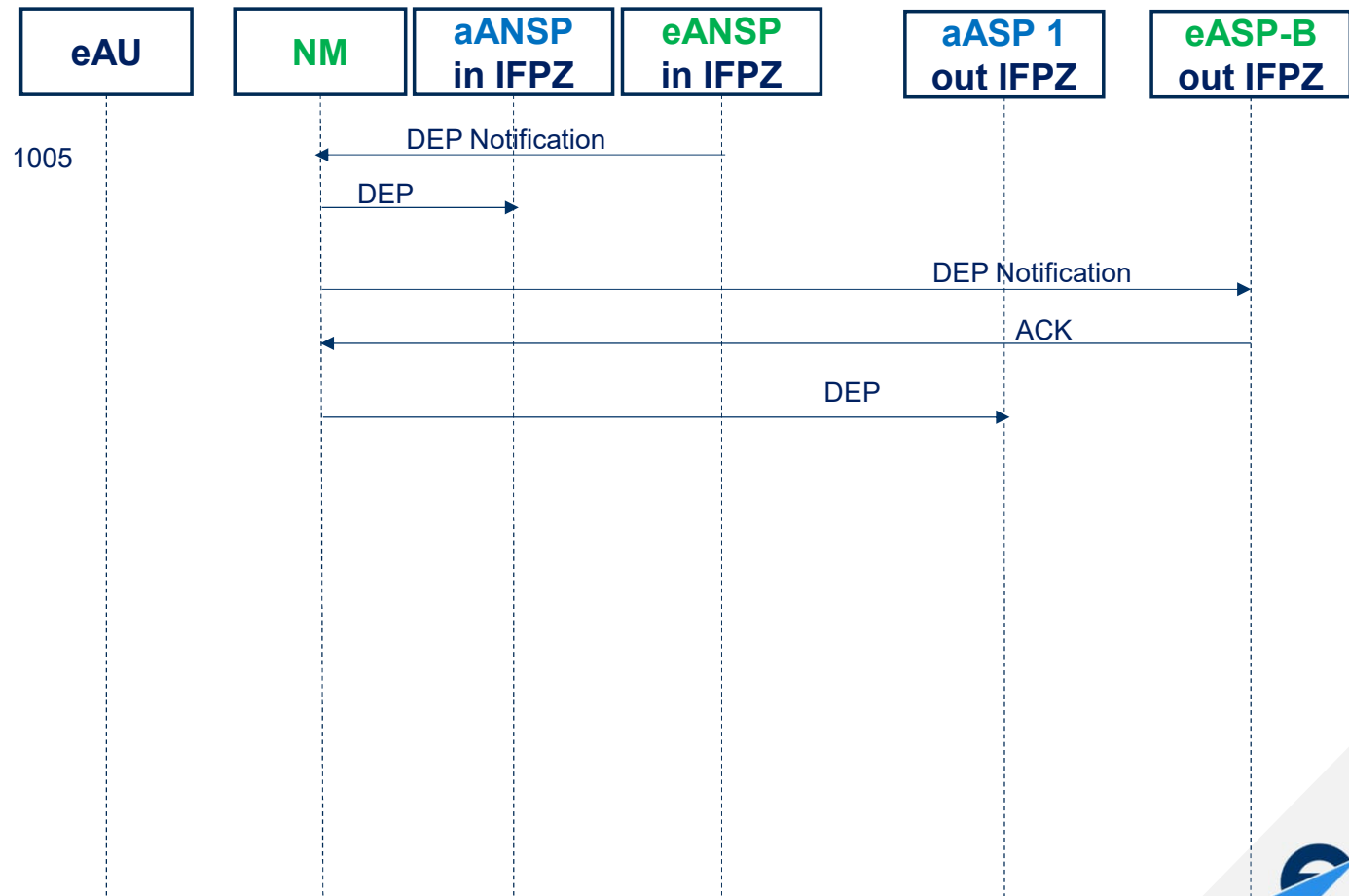

S1-UC2 – Sequence diagram (1)

Flight departing IFPZ and landing outside IFPZ (NM – aASP 1 – eASP-B) / Planning, Filing and Trial

- **Planning Service:** eAU submits a PFP (V1) for assistance in determining the optimal route/trajectory for the flight;
- **eASP-B** and **NM** respond with submission response “ACK” and subsequently with planning response (PS) CONCUR and NON-CONCUR;
- eAU is OK with the **NM** proposal from the Neg 4DT and sends PFP (V2) which is responded with CONCUR by **eASP-B** and **NM**
- **Filing Service:** eAU submits as per previous scenario but the eFPL is V3

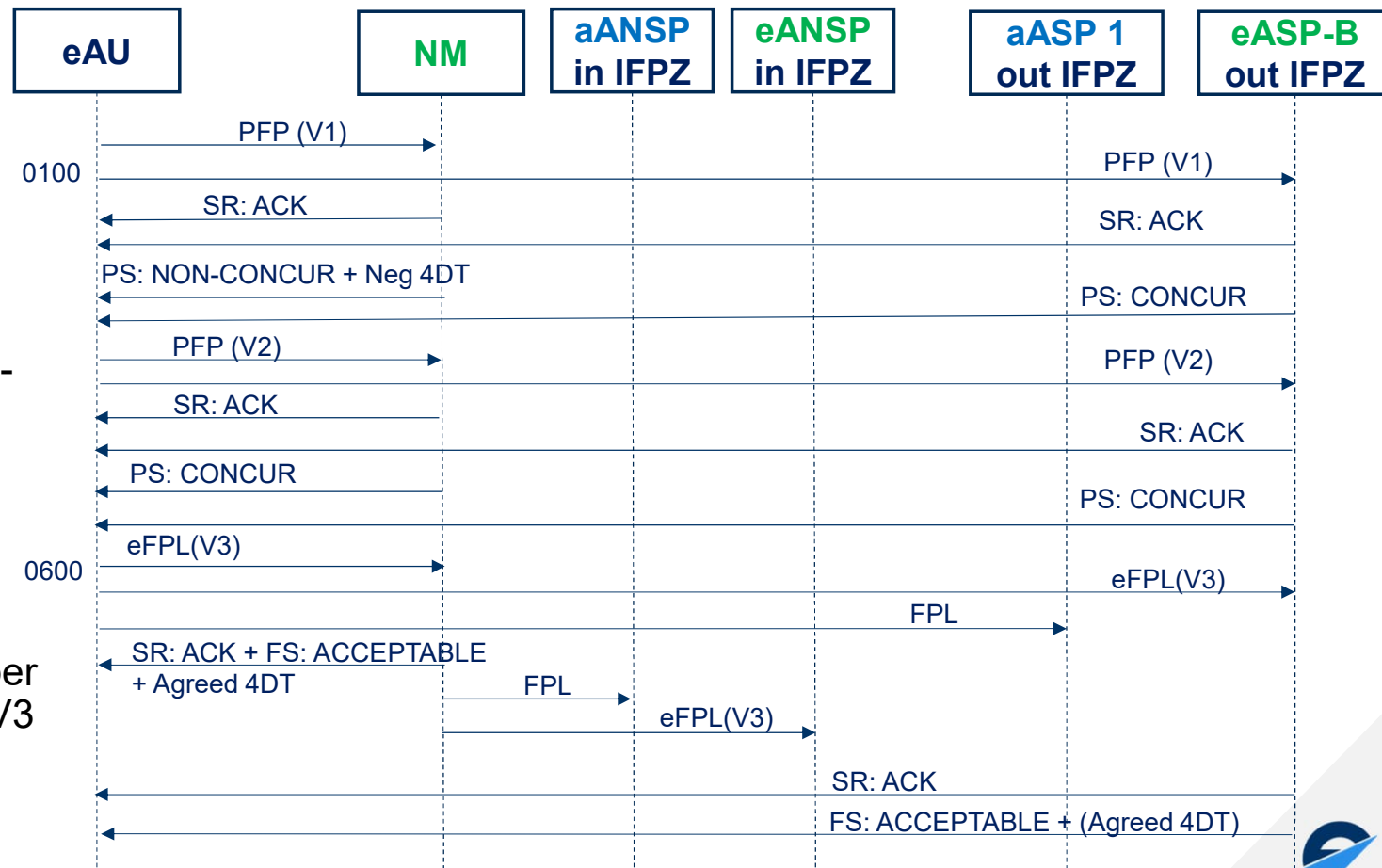

S1-UC2 – Sequence diagram (2)

Flight departing IFPZ and landing outside IFPZ (NM – aASP 1 – eASP-B) / Planning, Filing and Trial

- A restriction activation in aANSP area impacts the flight’s acceptability by NM
- **Re-evaluation** performed by NM captures the flight in the restriction. FS updated to NOT ACCEPTABLE to indicate eAU it needs to address the problem;
- **Trial Service**: eAU trials (TRQ) with NM only for alternative route and to ensure that the eFPL Update is accepted; NM responds CONCUR;
- **Filing Service**: eAU submits only eFPL Update (V4) with traj used in TRQ; no CHG required
- eASP-B responds with SR “ACK” and FS “ACCEPTABLE + Agreed 4DT”; NM responds with SR “ACK” + FS “ACCEPTABLE + Agreed 4DT”

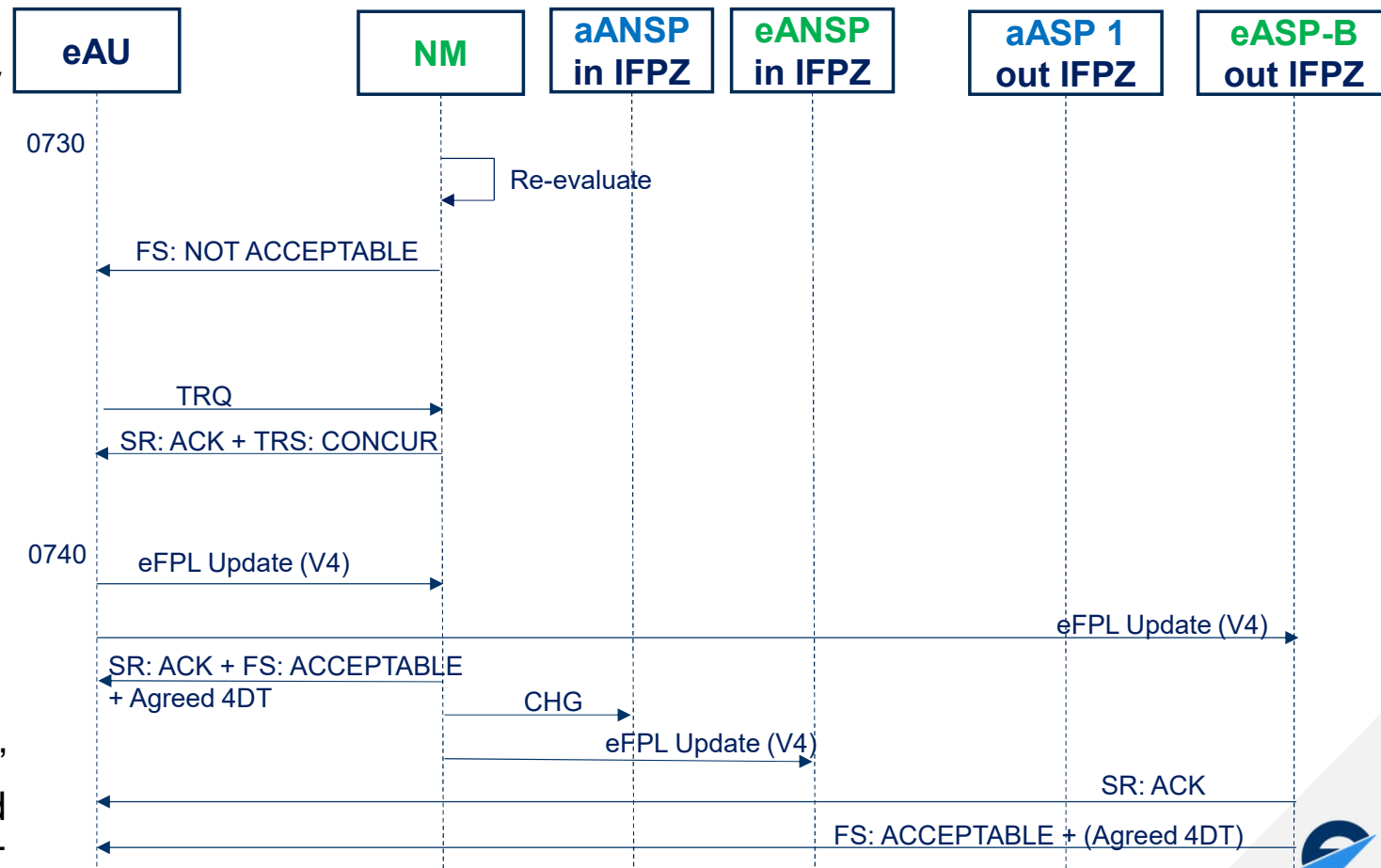

S2 – Sequence diagram (1)

Flight departing outside IFPZ and landing inside IFPZ (aASP 1 – eASP-B - NM) / Trial, Filing

- Trial Service:** eAU submits a trial request (TRQ) to verify flight plan validity before filing eFPL
 eASP-B and NM respond with submission response “ACK” and subsequently TRS: CONCUR
- Filing Service:** eAU submits eFPL to all eASPs and FPL to the aASP1
 eASP-B responds with SR “ACK” and FS: ACCEPTABLE + Agreed 4DT; NM responds with SR “ACK” + FS: ACCEPTABLE + Agreed 4DT
 ARO of aASP1 performs FPL distribution to all ASPs
 NM rejects the FPL with the explanation that the flight plan exists from AU. This is identical to when receiving a second FPL from different originator

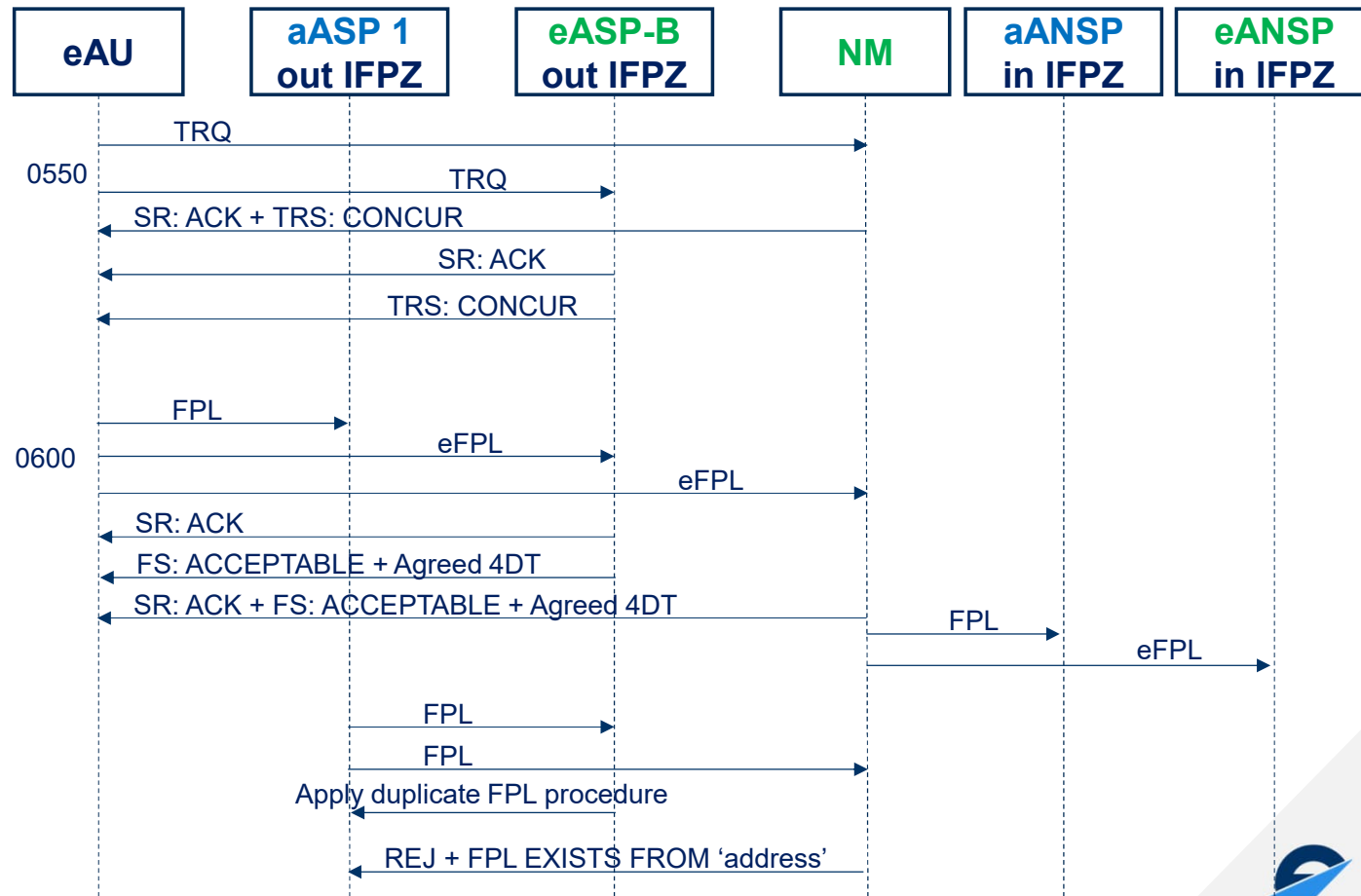

Take aways

- FF-ICE lay the groundwork for collaboration – no more ‘fire and forget’
- The first Filed Flight Plan may not be version “1”
- AUs are recommended to use Trial before any eFPL or eFPL Update submission
- Mixed mode can be challenging



SUPPORTING
EUROPEAN
AVIATION



Thank you!

ffice@eurocontrol.int

CONSORTIUM
COORDINATOR
sesar
DEPLOYMENT MANAGER

FOUNDING MEMBER
sesar
JOINT UNDERTAKING

NETWORK
MANAGER

