



**DANGEROUS GOODS PANEL (DGP)
WORKING GROUP MEETING (DGP-WG/22)**

Montréal, 21 to 25 November 2022

Agenda Item 2: Managing air-specific safety risks and identifying anomalies (REC-A-DGS-2025)

**TRANSPORT AIRPLANE CARGO COMPARTMENT FIRE SUPPRESSION CAPABILITIES,
REQUIREMENTS AND DANGEROUS GOODS ASSESSMENT IN THREE PARTS**

(Presented by the Secretary)

SUMMARY

Attached is the presentation delivered to DGP-WG/22 on Transport Airplane Cargo Compartment Fire Suppression Capabilities, Requirements and Dangerous Goods Assessment.

The Capabilities of Aircraft Cargo Compartments in Suppressing Fires Likely to Occur.

Presented to: ICAO DGP

By: Richard Hill

Date: 11/22/2022



**Federal Aviation
Administration**



Class C Compartment Capabilities:

Compartment Cargo Liners:

Temperature Profile Using JP4 as a Fire Source

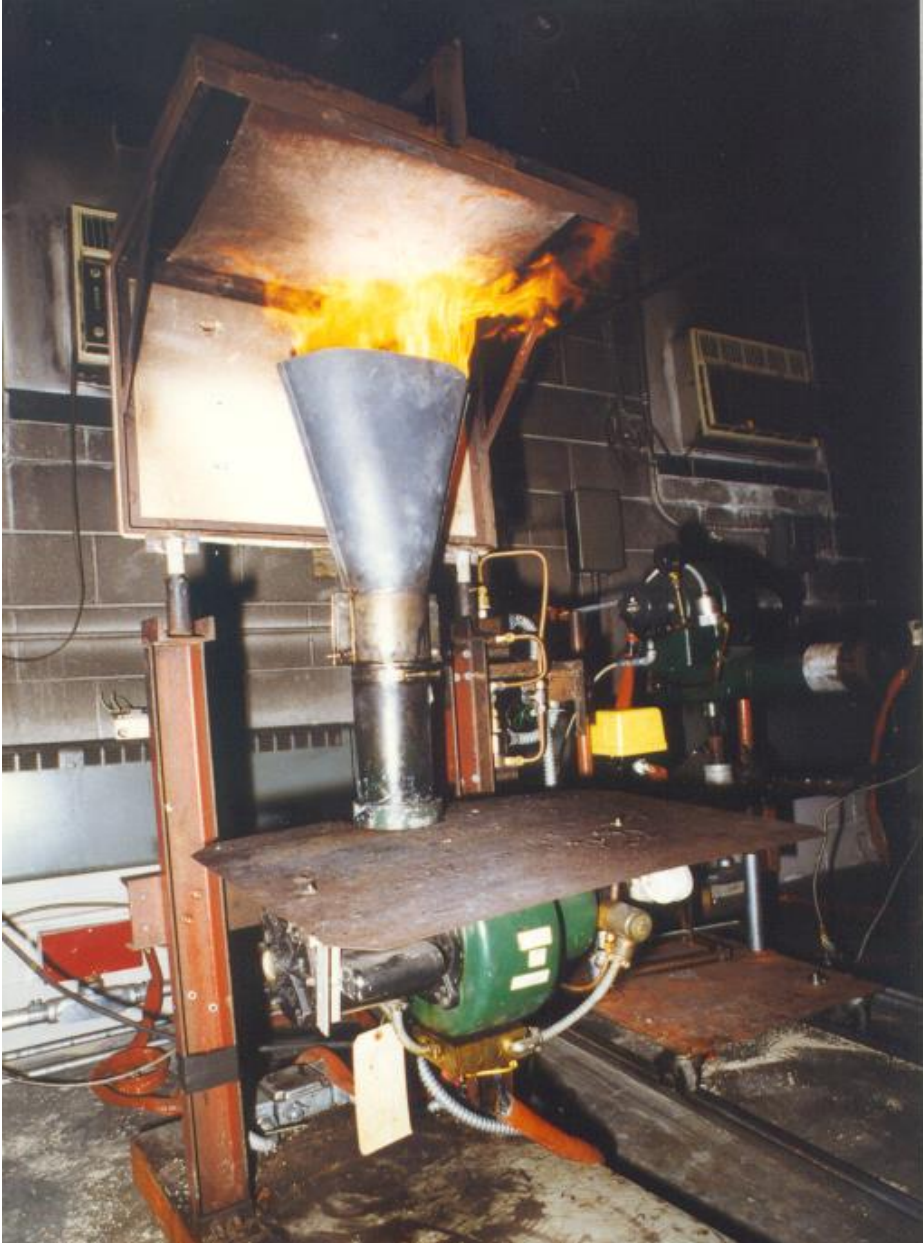
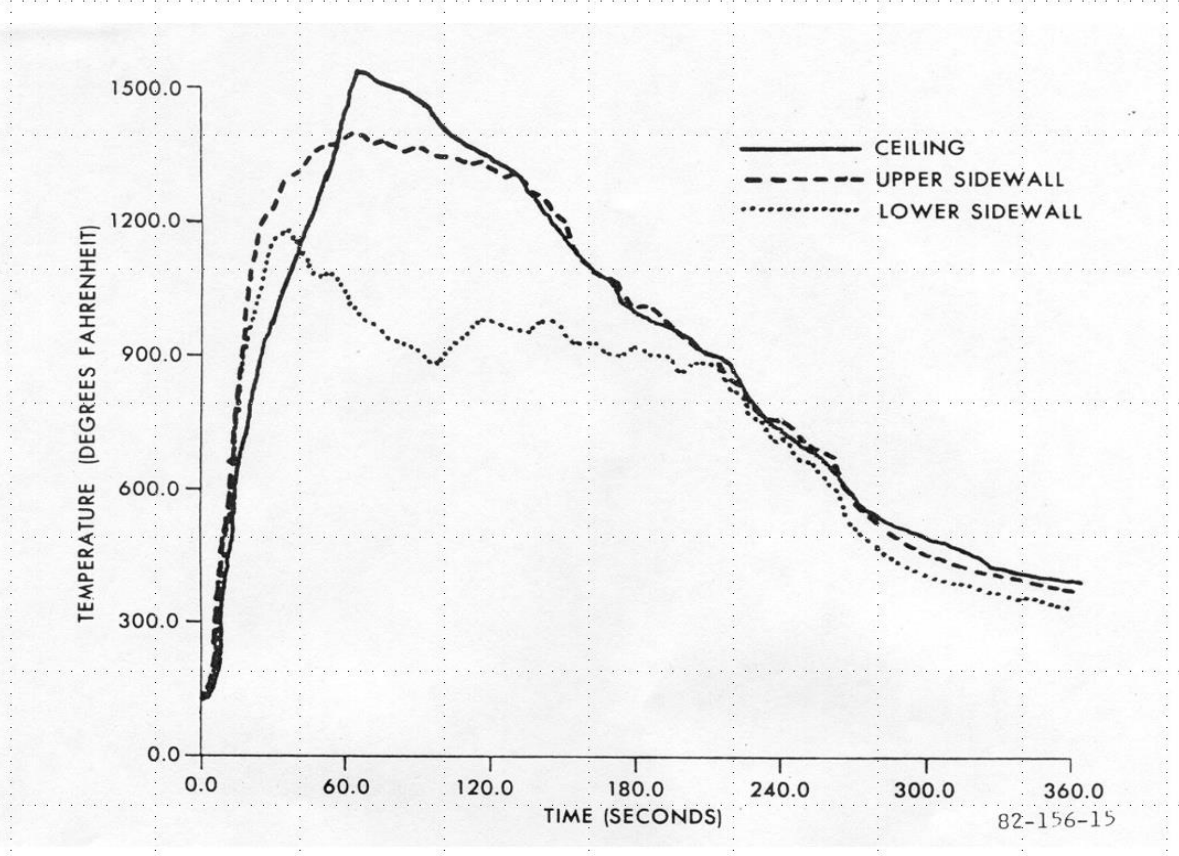

Class C Compartment Capabilities:

Cargo compartment pressure relief – approximately 1 psi.

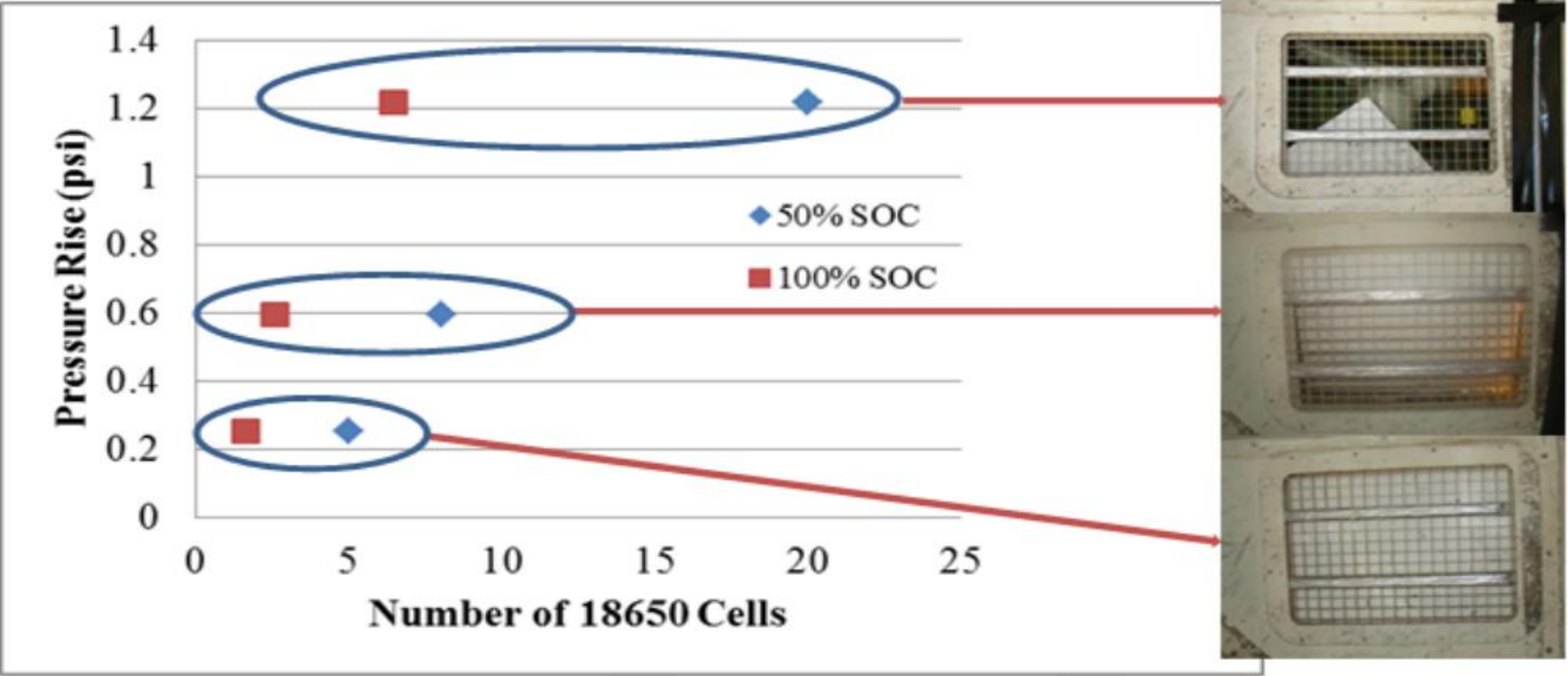

Figure 41. The 737 test results

Class C Compartment Capabilities:

(Halon 1301 – 5% knock down – 3% continuous)

Typical class “A” materials (cloth, wood, paper, rubber and plastics)

Will suppress for total length of flight with elevated temperatures

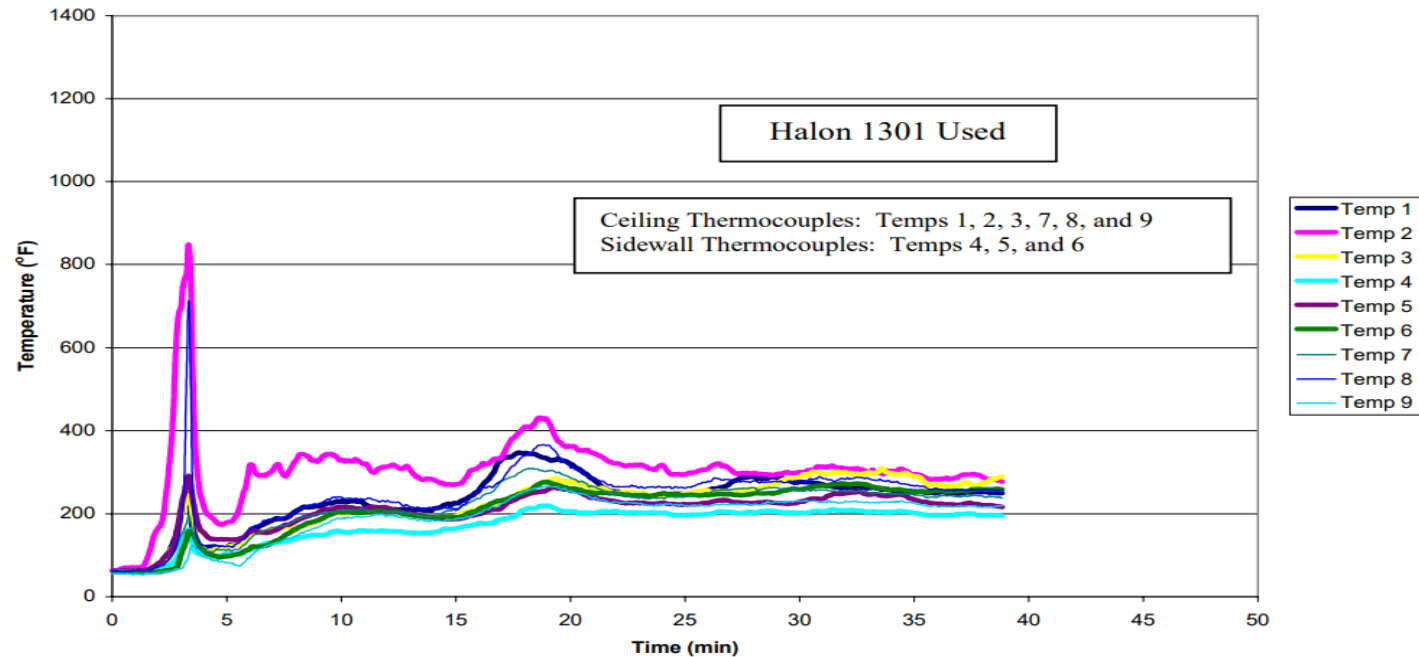

FIGURE 12. BULK-LOAD TEST 3 (081298T1) TEMPERATURE PLOT



Class C Compartment Capabilities:

(Halon 1301 – 5% knock down – 3% continuous)

Typical class “B” burning liquid hydrocarbon fuel.

Can completely extinguish.

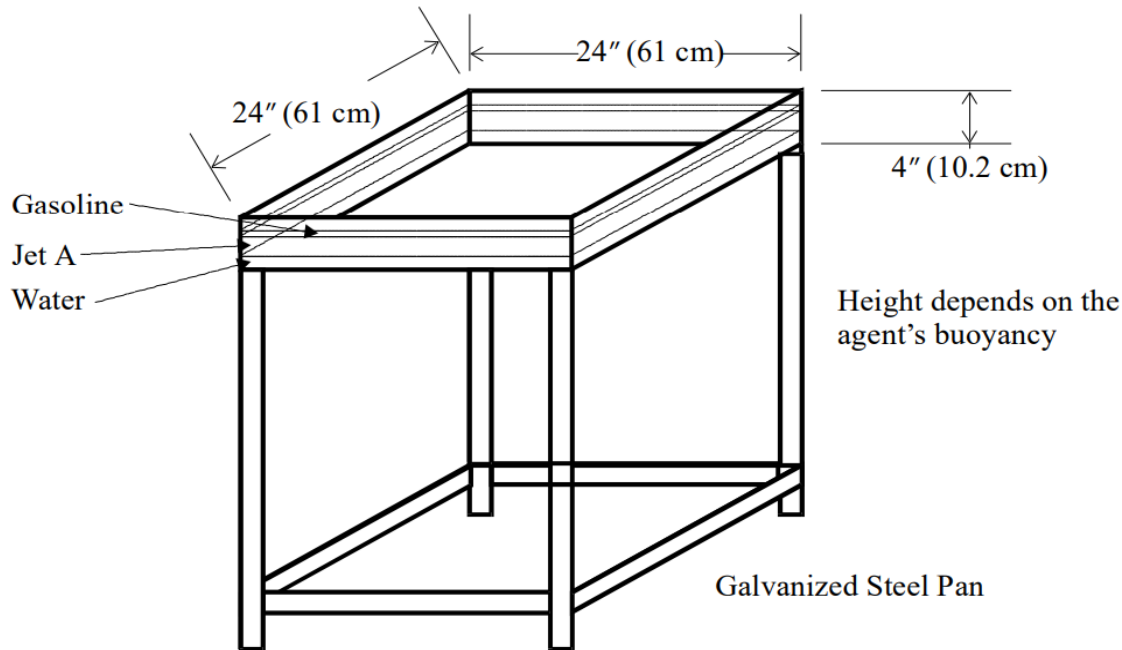

FIGURE 7. SURFACE BURNING FIRE PAN

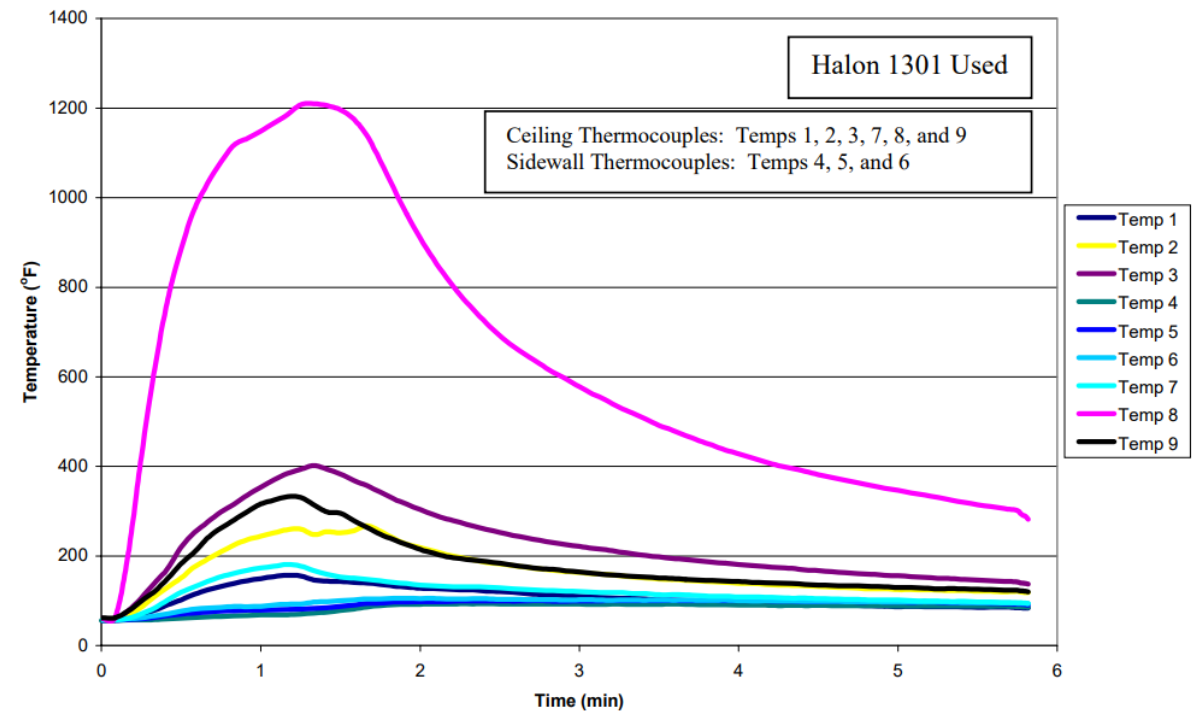

FIGURE 47. SURFACE BURN TEST 14 (111899T3) TEMPERATURE PLOT



Class C Compartment Capabilities:

(Halon 1301 – 5% knock down – 3% continuous)

Exploding aerosol can:



Federal Aviation
Administration

Class C Compartment Capabilities:

(Halon 1301 – 5% knock down – 3% continuous)

Chemical O2 generators:

Can not suppress.



Class C Compartment Capabilities:

(Halon 1301 – 5% knock down – 3% continuous)

Hydrogen Gas:

Greater than 20% Halon 1301 needed for suppression

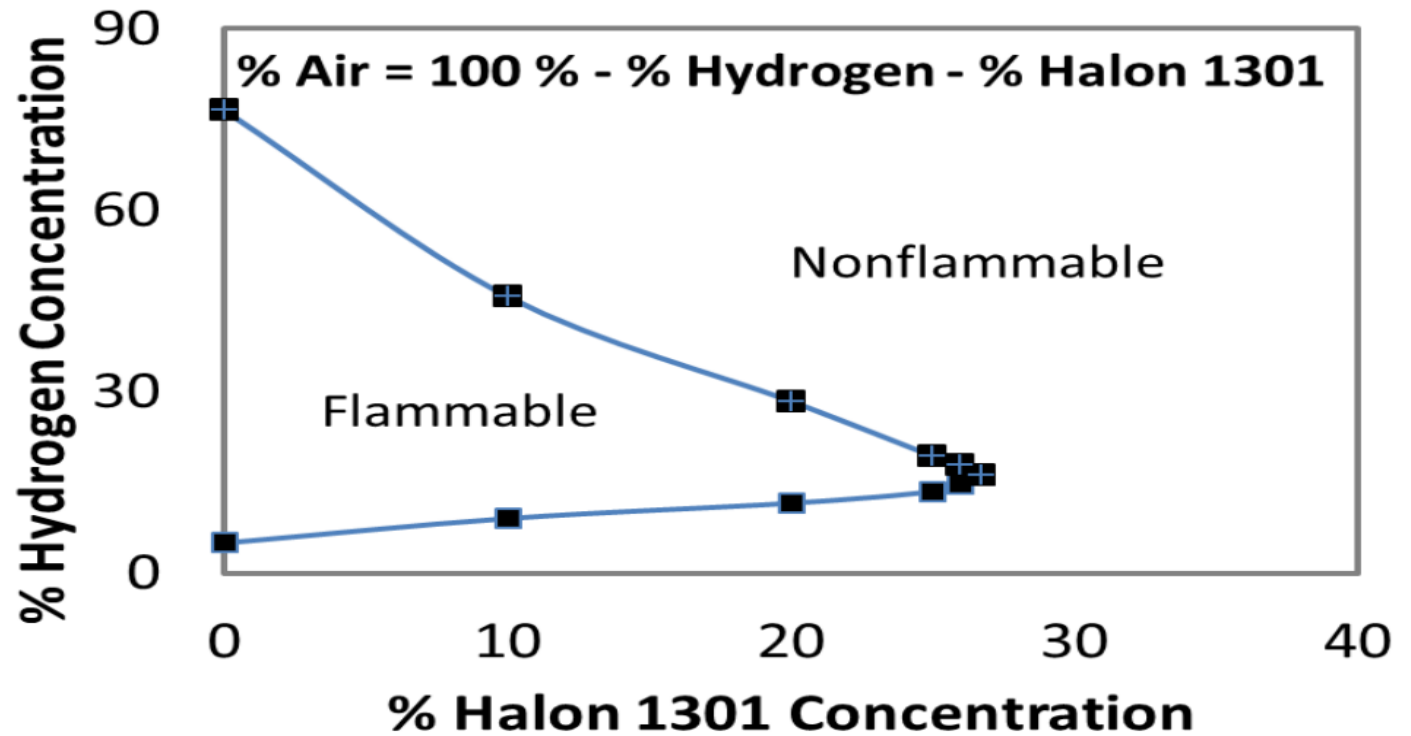

Class C Compartment Capabilities:

(Halon 1301 – 5% knock down – 3% continuous)

Lithium Battery Gas:

Greater than 9% Halon 1301 needed for suppression

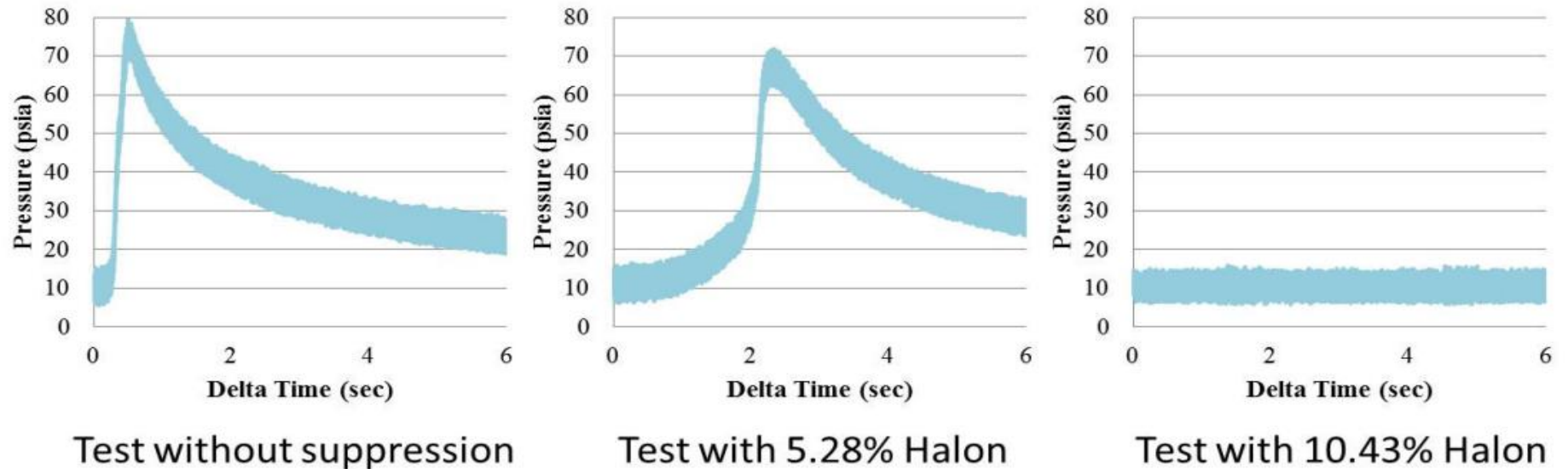

Figure 35. High-speed pressure profile for combustion of three Halon concentrations



Class E Compartment Capabilities:

(Oxygen starvation)

Compartment Cargo Liners (where needed to protect critical components):

Most part 25 freighters complete linings.



Class E Compartment Capabilities:

(Oxygen starvation)

Flight deck – cargo compartment segregation:

Physical and pressure differential

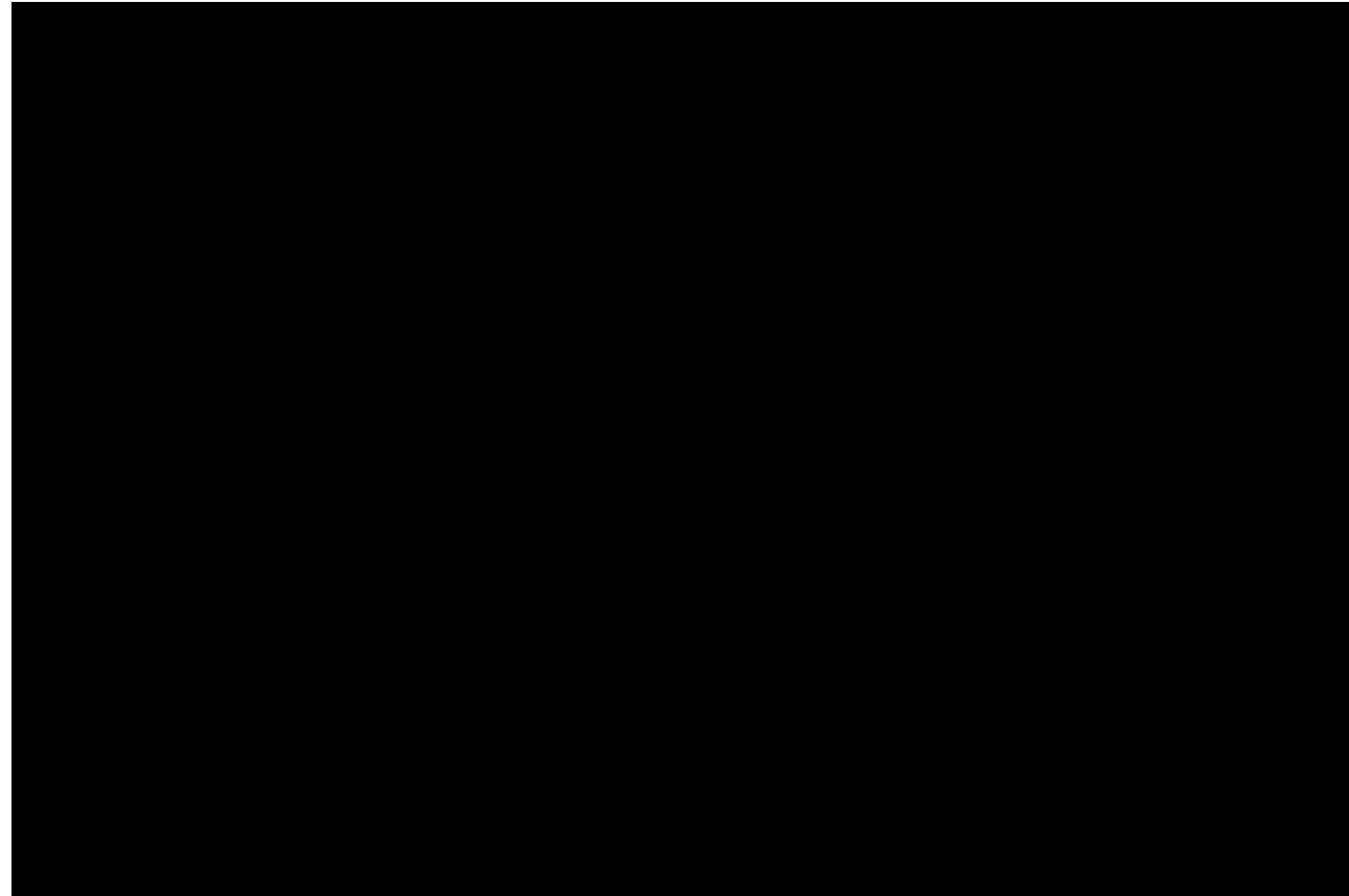

Class E Compartment Capabilities:

(Oxygen starvation)

Depressurization for long term control:

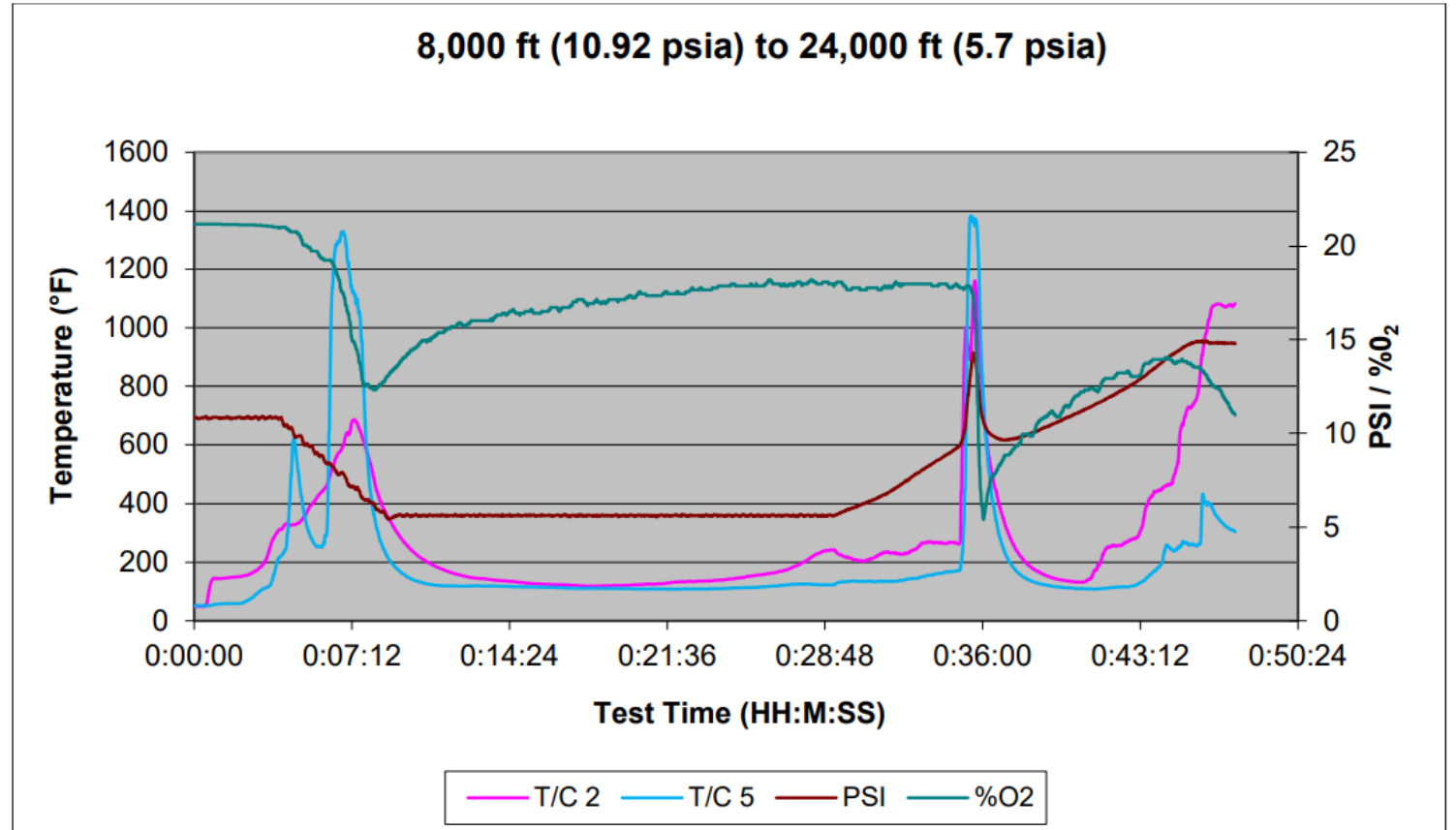

Figure 13. Depressurizing to 24,000 ft (~5.7 psia)



Class E Compartment Capabilities:

(Oxygen starvation)

Can slow burning liquid hydrocarbon:

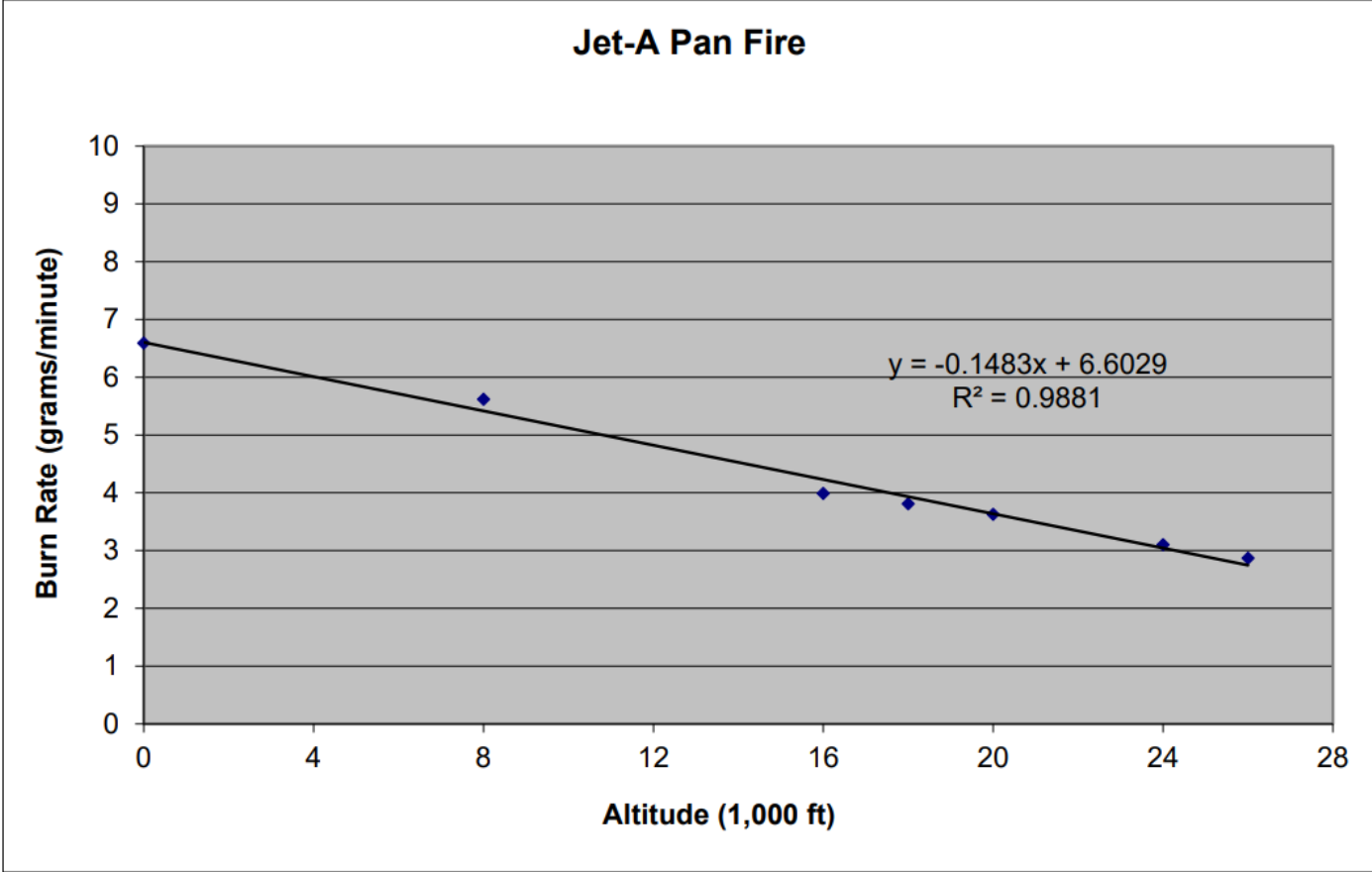

Figure 2. Jet-A pan fire

Class E Compartment Capabilities:

(Oxygen starvation)

Can not control battery propagation

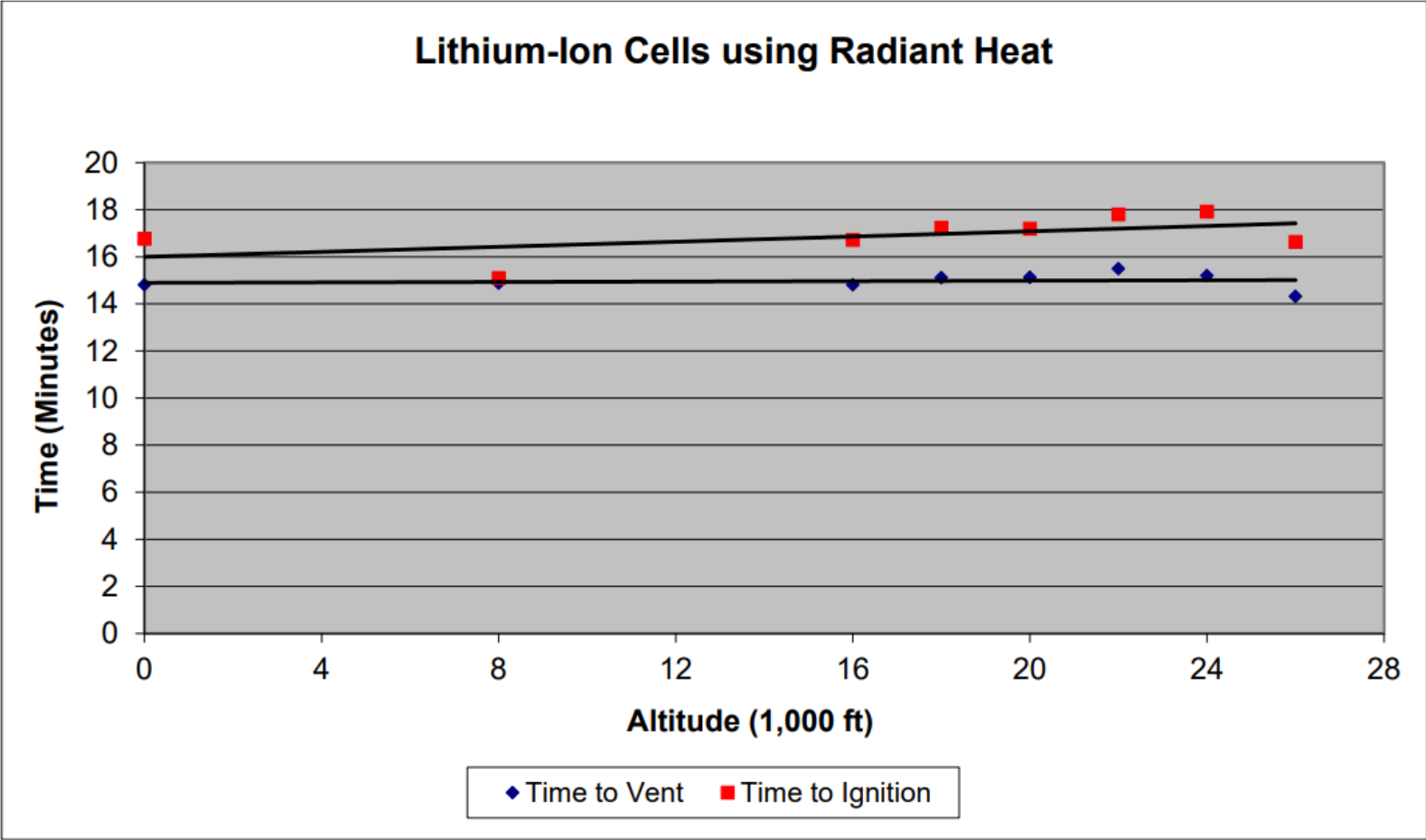

Figure 6. Lithium-ion cells using radiant heat

Class E Compartment Capabilities:

(Oxygen starvation)

May reduce rate of battery propagation
By reducing rate of adjacent heating.

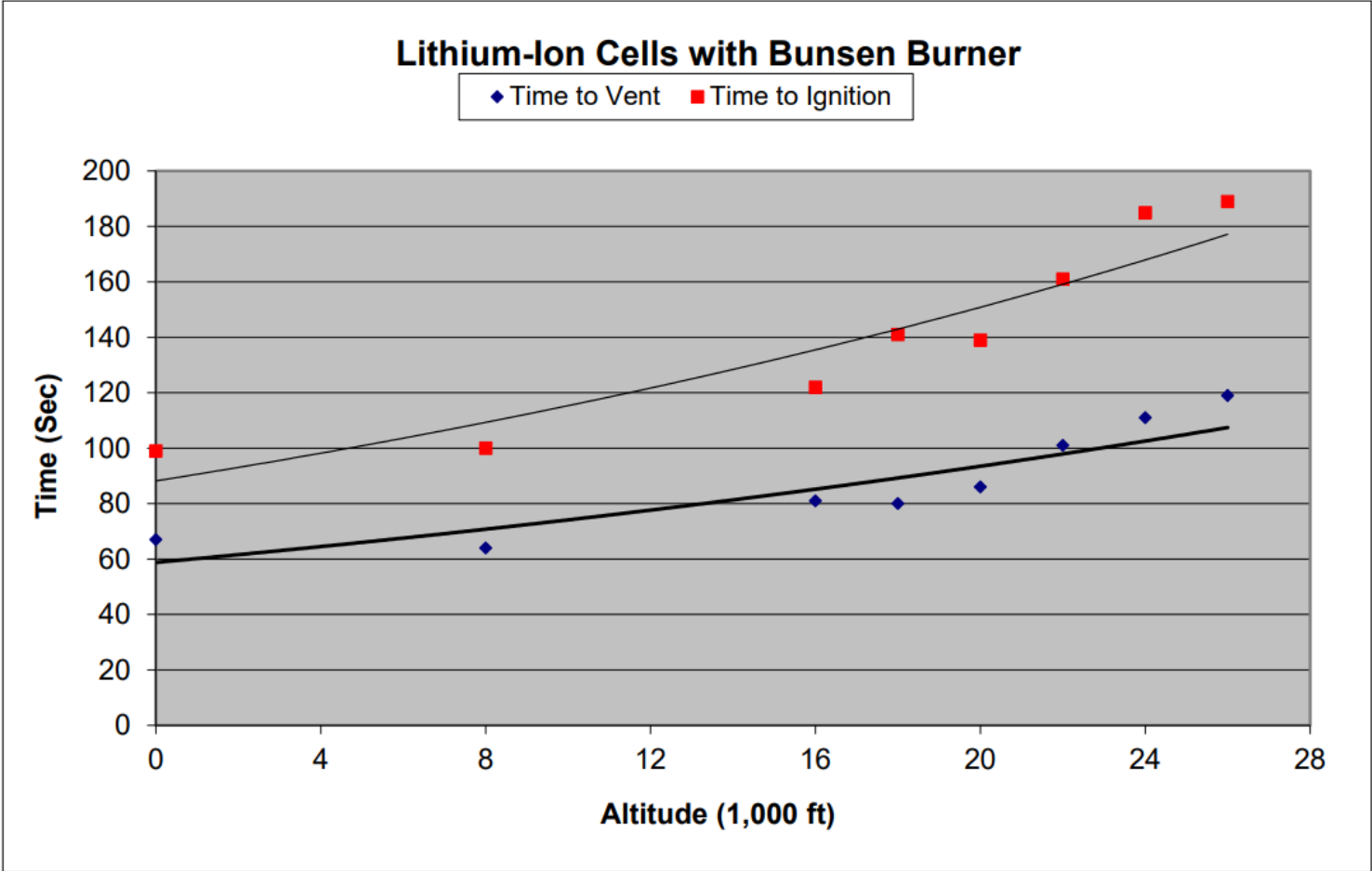
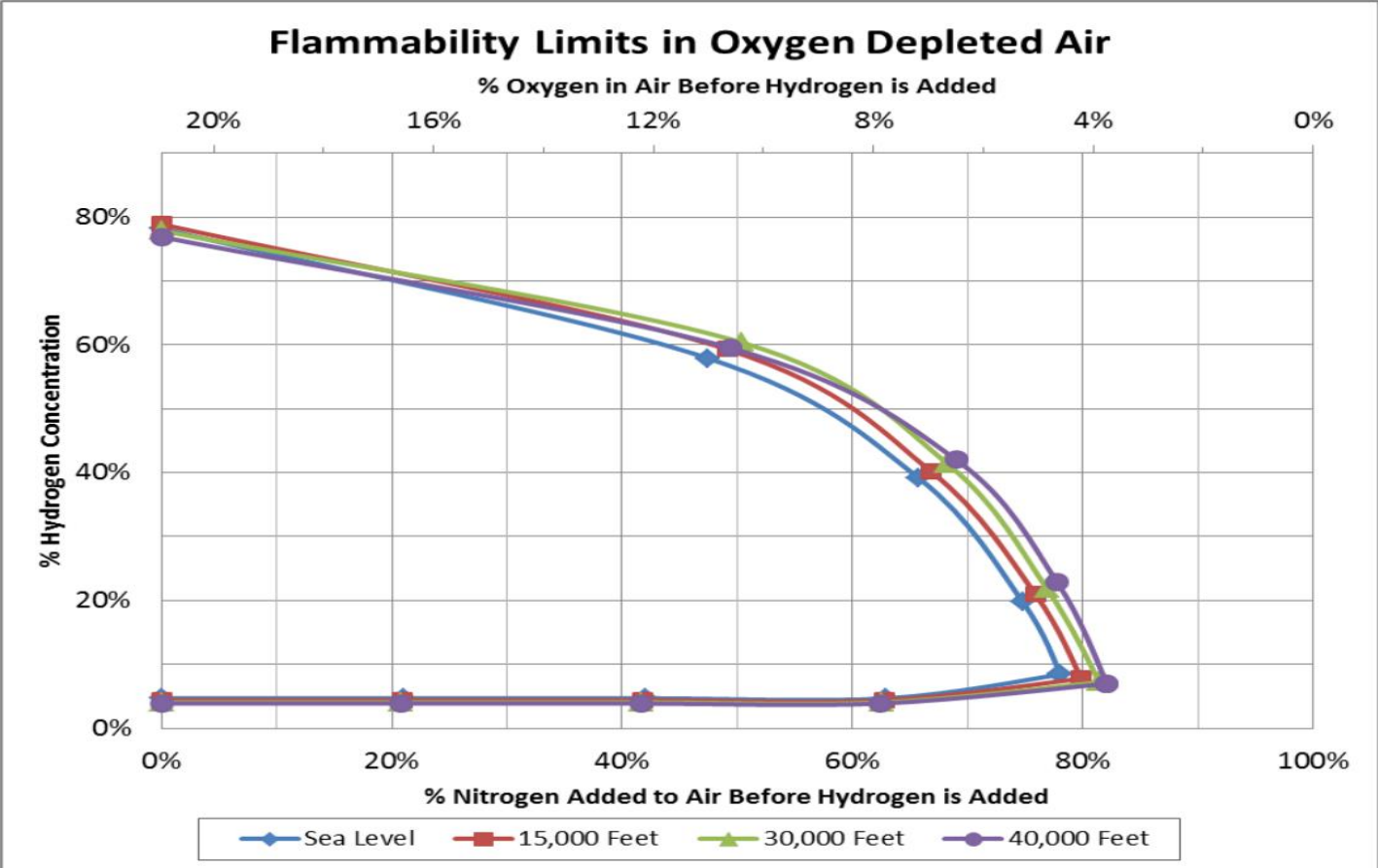

Figure 4. Lithium-ion cells using Bunsen burner

Class E Compartment Capabilities:

(Oxygen starvation)

Effect of O2 reduction and depressurization on Hydrogen Flammability:



Cargo Fire Risk

Jeff Gardlin, Chief Scientific and Technical Advisor for Advanced Cabin Safety

ICAO DGP

November 22, 2022



Federal Aviation
Administration

STEP SENIOR TECHNICAL
EXPERTS PROGRAM
ADVANCING SAFETY THROUGH SCIENCE

Cargo Fire Protection



- All cargo compartments require fire protection
- Details of the fire protection systems vary by compartment type, as just discussed
- The probability of a fire is not a factor in determining *whether* fire protection is required
- Although a cargo fire is an assumed condition, this is not the same as assigning a “probability of 1”

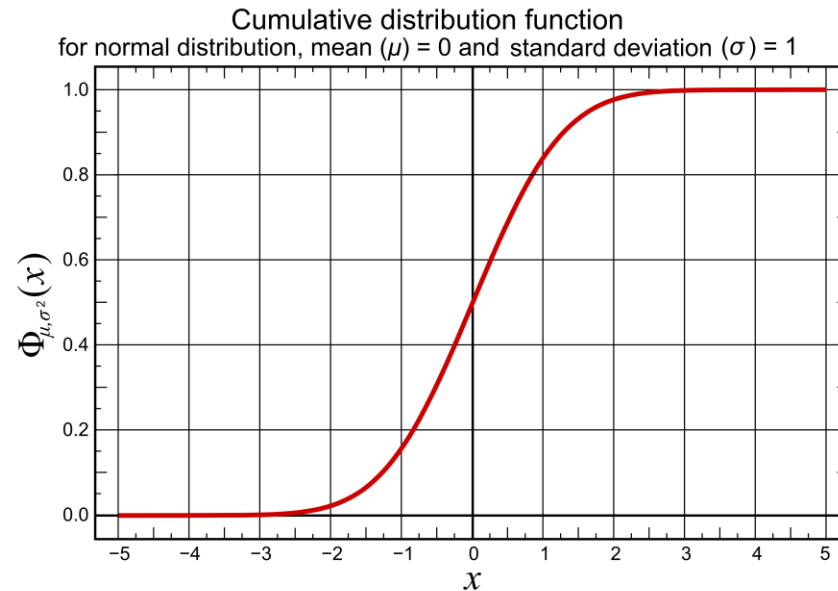
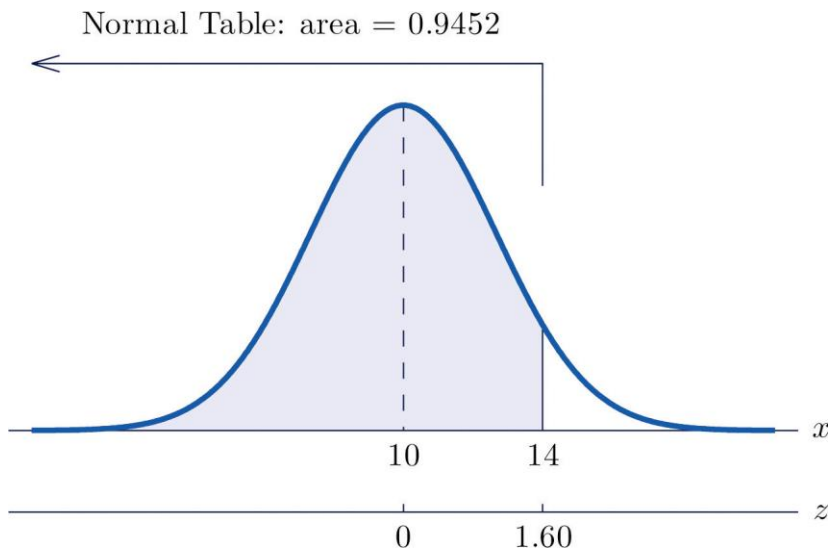

Risk: Likelihood and Severity



- The risk of an undetected cargo fire is considered catastrophic
- Therefore the combination of a fire and a failure to detect it must be extremely improbable, i.e., no greater than 10^{-9} / flight hour
- Does that then mean if the probability of a fire is x , the detector can be $1-x$?
- ❖ e.g, if the probability of a fire is 10^{-8} therefore detector reliability can be 10^{-1} ...
- NO! The undetected fire could result from many things beyond just the reliability of the detector



Likely to Occur?



- A fire per se is not “likely” to occur
- Generally accepted rate of a cargo fire is 10^{-8} to 10^{-7} per flight hour
- However, the rate is not static
 - Changes in operational characteristics
 - Changes in cargo
 - Changes screening
- Moving the number an order of magnitude would reflect a significant change in conditions
- Addressing the risk of an undetected fire doesn’t mean that the risk of a *detected* fire is zero



Likely to Occur?



- The regulations specifically state that fire suppression systems cater to ‘fires likely to occur’
- Although a fire itself is not likely, fires likely to occur are based on what is carried
 - Ignition sources
 - Fuel
- This is also not static
 - Aircraft designs are updated but not in real time
 - Regulatory standards evolve regarding what can be carried
- If the systems and the fire likely to occur (if there is one) are not compatible, something needs to change
 - Change the systems
 - Aircraft level
 - ULD level
 - Package level
 - Change what is carried





- There will be cargo fires—not very often, but eventually
- The potential that a fire can exceed the capability of the aircraft can result from a number of factors
 - Some managed from the design
 - Some managed elsewhere
- Maintaining compatibility between the fire protection systems, procedures and equipment with the type of fire that can occur is key



Safety Risk Assessments Involving Lithium Ion Cells/Batteries in and with equipment shipped via Air (UN 3481)

Presented to: ICAO DGP

By: Richard Hill

Date: 11/22/2022



**Federal Aviation
Administration**



My Analysis

Ask two questions:

1. If a fire starts in an aircraft cargo compartment, is it likely to have been started by UN3481?
2. Is UN3481 likely to be involved in the fire?

1 depends on if UN3481 shipments start fires, and 2 depends on the volume of UN3481 shipments (probability on being in a compartment when there is a fire).



Lithium Battery Incidents

As of May 1, 2022*, there have been 365 air/airport incidents, that the FAA is aware of, with smoke, fire or extreme heat involving lithium batteries (mainly US-based)

Date of Incident	Type Carriage	Category	Reported Description
04/26/22	Cargo	Battery Packs/Batteries	<i>A package containing devices powered by Lithium ion batteries was discovered burnt and charred at a cargo processing facility. A device within the package reportedly went into thermal runaway while in transportation but did not spread to other devices within the package. There were no injuries reported.</i>
04/19/22	Passenger	Battery Packs/Batteries	<i>An e-Cigarette Lithium battery began to overheat during flight. The battery was placed within a thermal containment bag.</i>
04/16/22	Cargo	Laptop	<i>A package containing a laptop computer began to smoke at a cargo sort facility. The computer was reportedly being returned to the manufacturer with previous damage. The smoking package was isolated and placed into a salvage drum for containment. There were no injuries reported</i>

<https://www.faa.gov/hazmat/resources/lithium-battery-incident-chart>

* Since January, 2006

Thermal Runaway

Incident

Program



TRIP is a secure, Lithium battery incident surveillance system.

- Replaces a voluntary incident capture and reporting process originally administered by American Airlines
- Capture incident data and aggregate information from multiple sources
- Maintain data in a more granular and consistent manner
- Provide participant airline-specific and anonymized industry data views based on user permissions
- Provide on-demand reporting and data analysis capabilities

UN Classification	2017	2018	2019	2020	2021	Total
UN 3090 – Lithium metal batteries	1	0	0	0	0	1
UN 3091 – Lithium metal batteries contained in or packed with equipment	0	0	0	0	0	0
UN 3480 – Lithium-ion batteries	11	10	6	3	3	33
UN 3481 – Lithium-ion batteries contained in or packed with equipment	2	6	2	1	3	14
Not specified	1	6	6	5	2	20
Total	15	22	14	9	8	68

From this inference, at least 20% of shipments involving thermal runaway have occurred with batteries contained in or packed with equipment.



1. If a fire starts in an aircraft cargo compartment, is it likely to have been stated by UN3481?

My answer - YES



UN3481 Imports to and Exports from U.S. by Air (2015 – 2021)

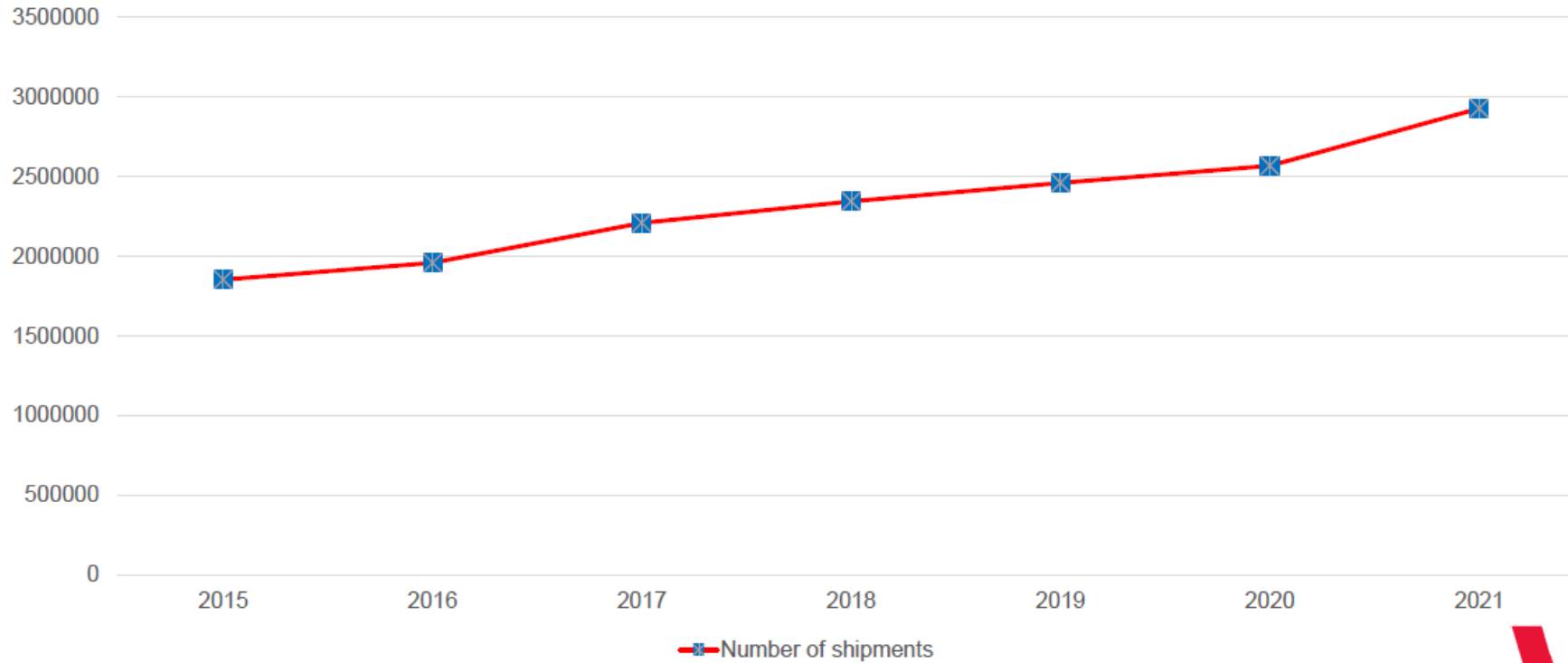

October 20, 2022

Source: U.S. Bureau of the Census trade data and Campbell-Hill Aviation Group

6



1. Is UN3481 likely to be involved in the fire?

My answer - YES



Last Question, #3:

Is the aircraft capable of controlling those fires?



Why are Lithium Batteries Hazardous?

Can Self Ignite From:

Internal Short (from damage or production flaw)

External Short

Rapid Discharge

Over Charge

External Heat

Can Propagate from Cell to Cell.

Produce Combustible Gases:

Hydrocarbons

Carbon Monoxide

Hydrogen



Tablet Pouch Cell in Thermal Runaway



Laptop in Box for Shipping

Risk in Class C Compartment is a Fire that Can Not be Controlled by the Halon 1301 Suppression System

Why? Because:

Halon 1301 Can Not Stop the Thermal Runaway Process.

Halon 1301 Will Not Stop Cell to Cell Propagation.

The Current Required Concentration of Halon 1301 Will Not Prevent the Ignition of **Hydrogen Gas.**

What Does That Mean?

A Fire Involving Lithium Batteries Could Self Propagate, Even in the Presence of Halon 1301, Releasing Combustible Gas that Could Ignite and Cause an Overpressure, With Compartment Damage, That May effect the Ability of the Suppression System to Control a Fire.



Risk in Class E Compartment is a Fire that Can Not be Controlled by the Oxygen Starvation.

Why? Because:

**Lack of Oxygen Can Not Stop the Thermal Runaway Process.
Lack of Oxygen Will Not Stop Cell to Cell Propagation.
The Rapid Release of Combustible and Explosive Gas Can Produce a Fire With A Greater Intensity than the Compartment was Designed for.**

What Does That Mean?

A Fire Involving Lithium Batteries Could Self Propagate, Releasing Combustible and Explosive Gas, that Could Ignite and Cause an Intense Fire that Could Cause, Compartment, Flight Controls and Structural Damage, and an Overpressure, that Could Cause Smoke to Enter the Flight Deck.



Energy Density of Lithium-ion Battery Packs, 2008-2020

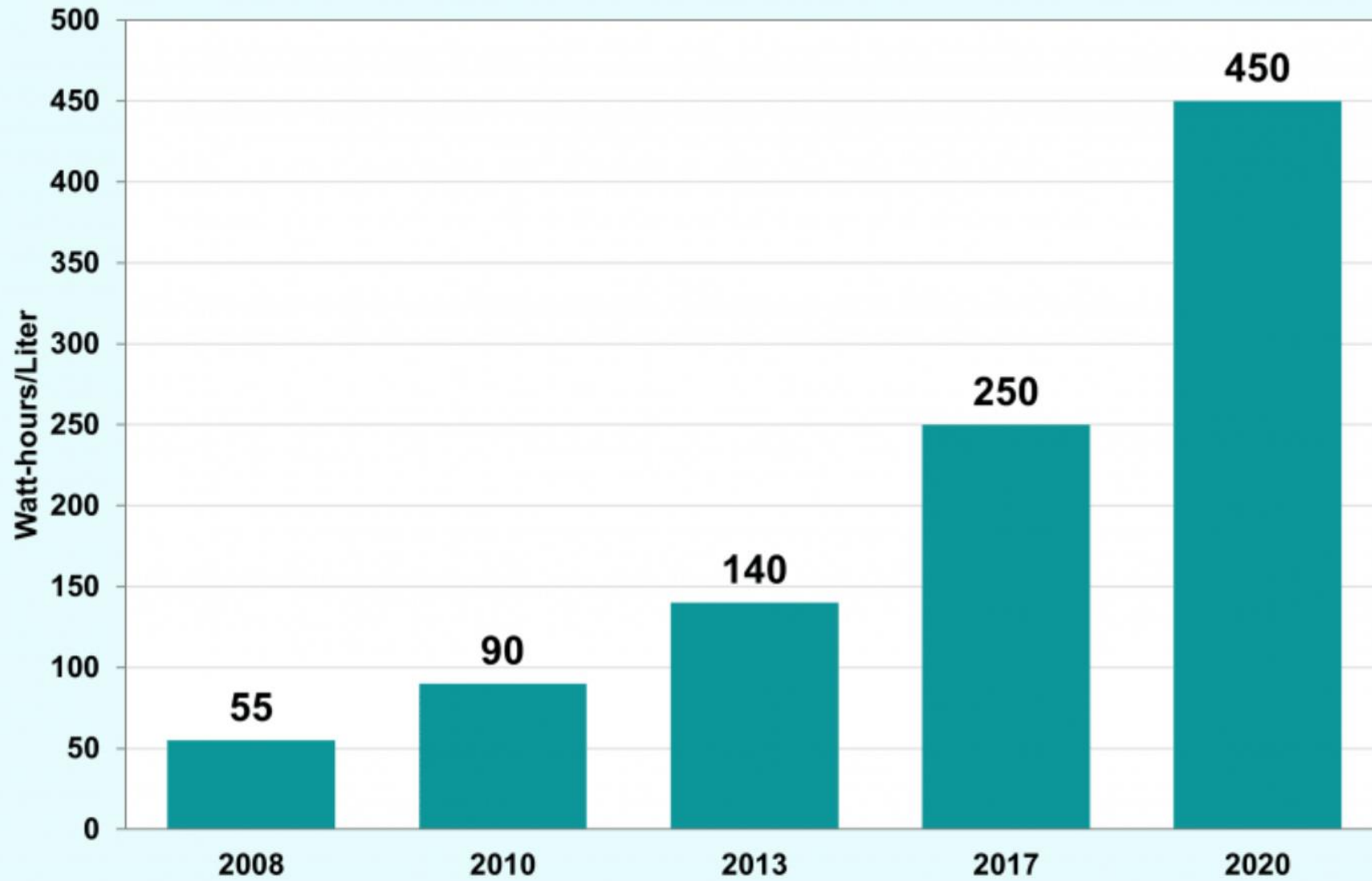

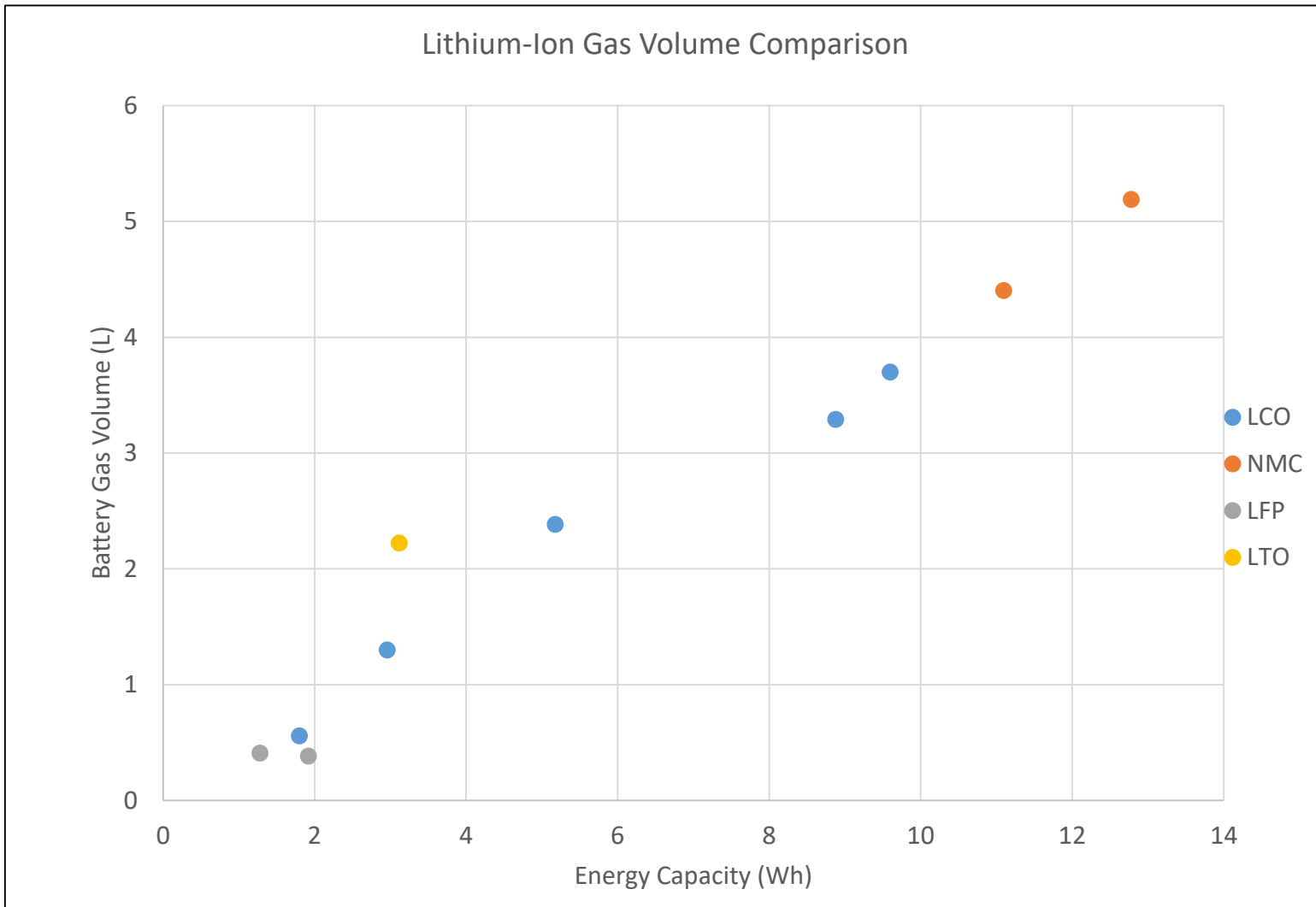

Battery Gas Volume Measurements

Lithium-ion cells



Laptop in cardboard box



Laptop in Cardboard box

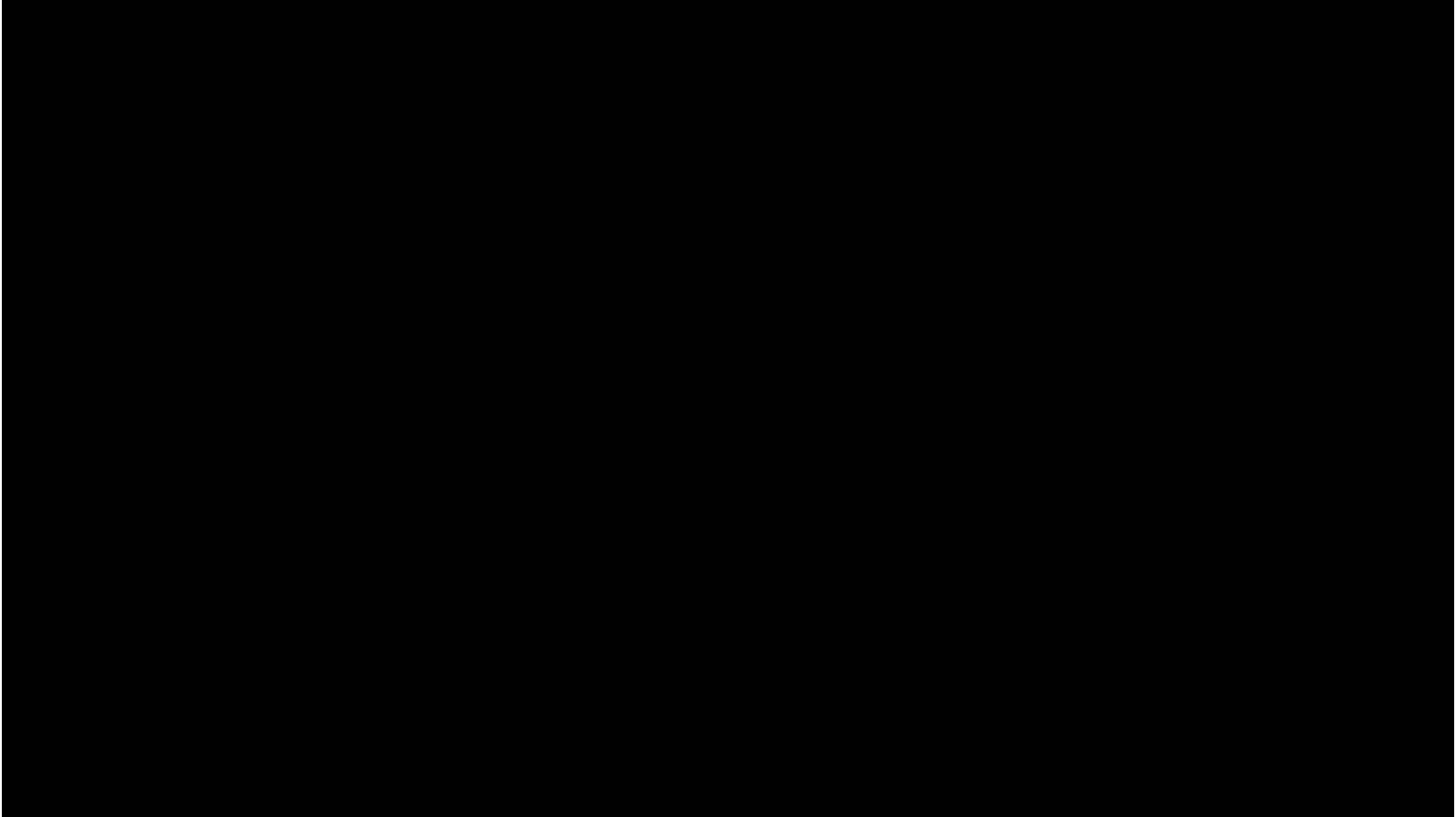

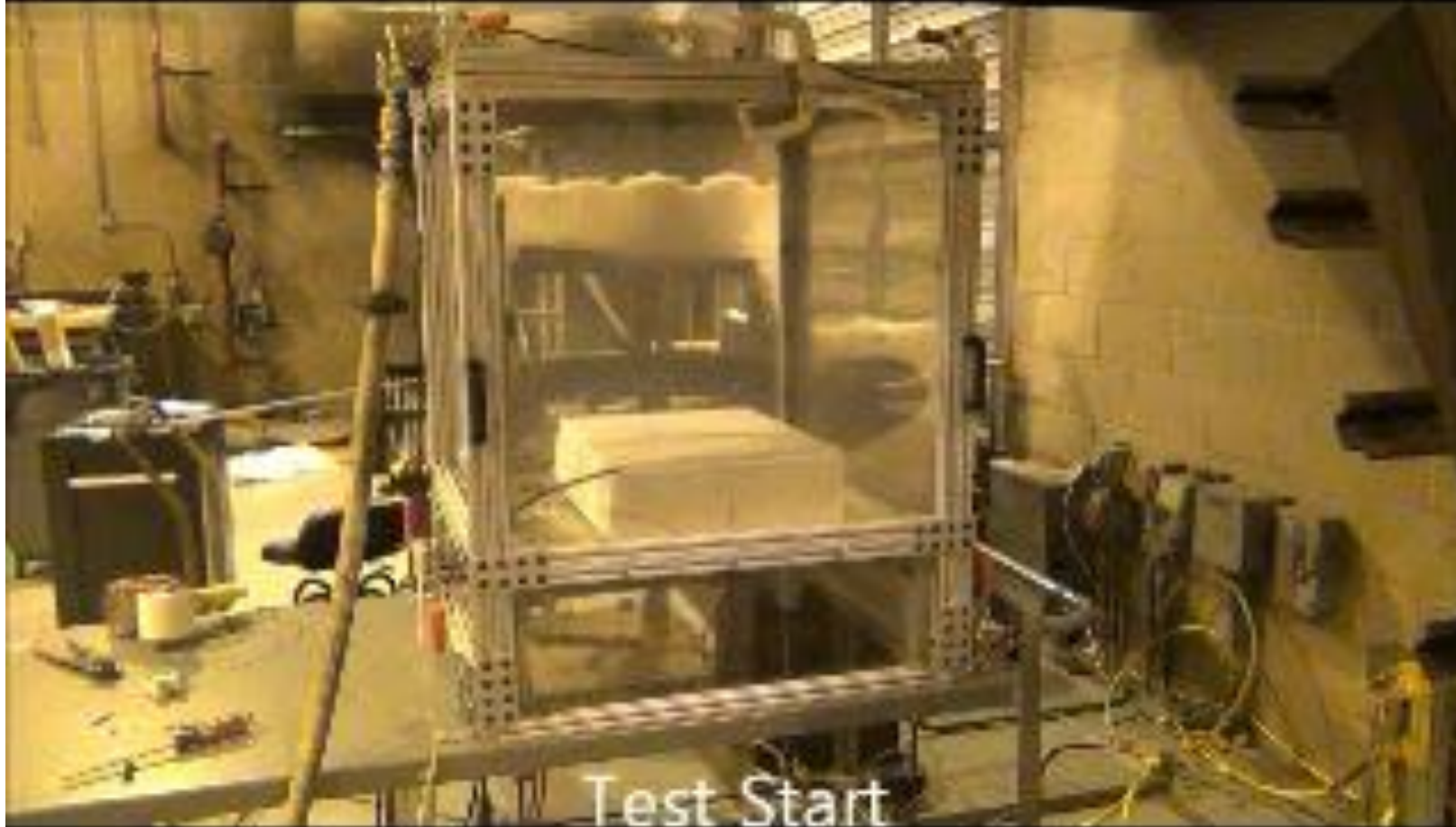



Federal Aviation
Administration



VIDEOS

SUBSCRIBE NOW



Federal Aviation Administration



A Let L-410UVP-E3, 9S-GFA, burnt out at Bukavu-Kavumu Airport, D.R. Congo.

The aircraft was carrying 1600 kgs of cargo bound for Lulingu, D.R. Congo. Local media reports suggest that a fire developed on board the aircraft after takeoff. The pilots reportedly returned to Kavumu Airport and evacuated from the aircraft.

The fire quickly engulfed the cabin of the aircraft and fire services were not able to contain the fire. The aircraft burned out completely.



My answer to question #3:

For class C compartments – **No!**

For Class E compartments – **No!**

Risk Reduction Methods:

Fire containment covers
ULD with suppression
Trusted vendor program

Fire resistant containers
Fire hardened overpacks

My choice:

Reduce state of charge to **30% or less!**



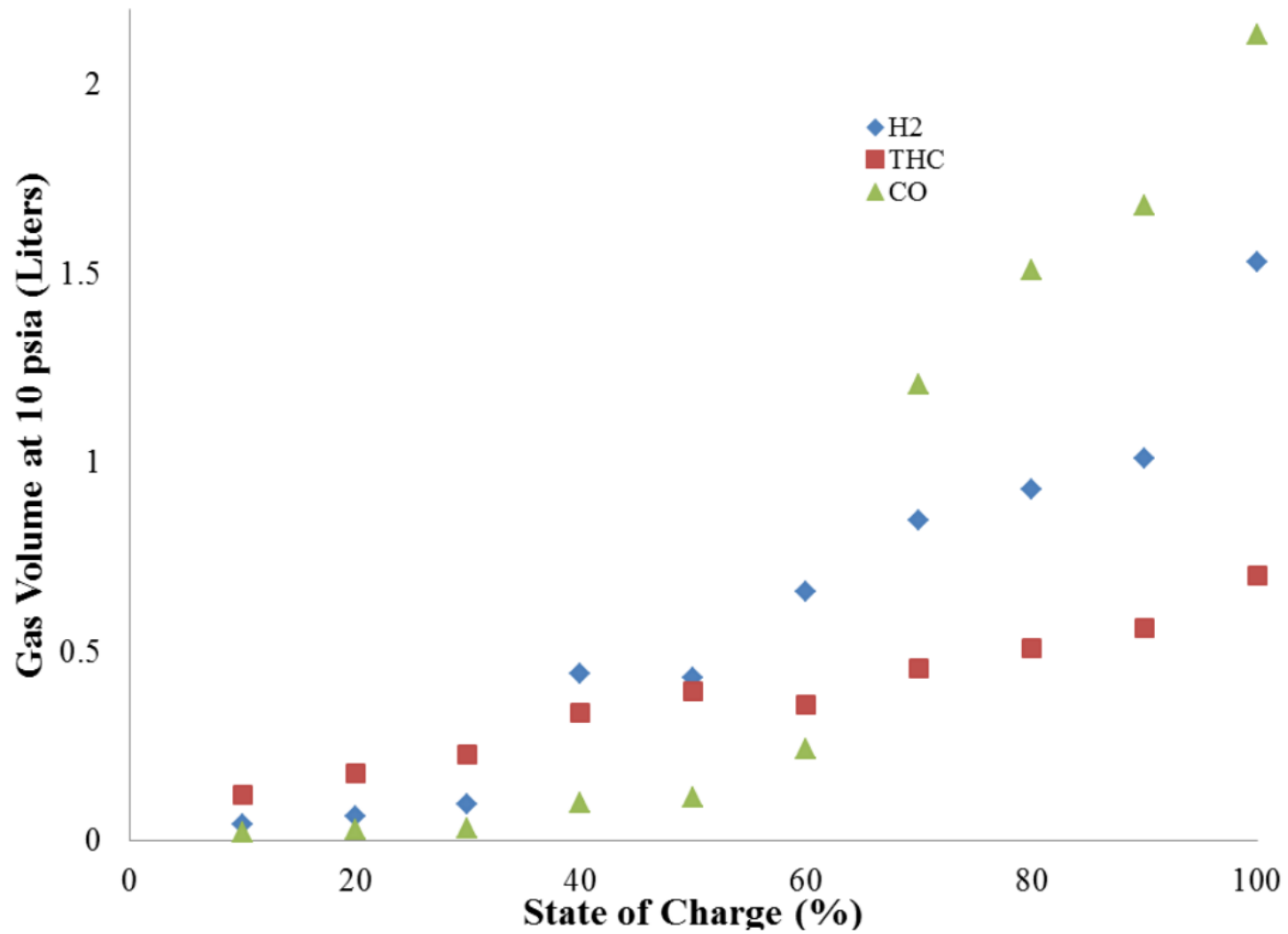

Figure 31. Flammable gases emitted from LiCoO₂ 18650 cells



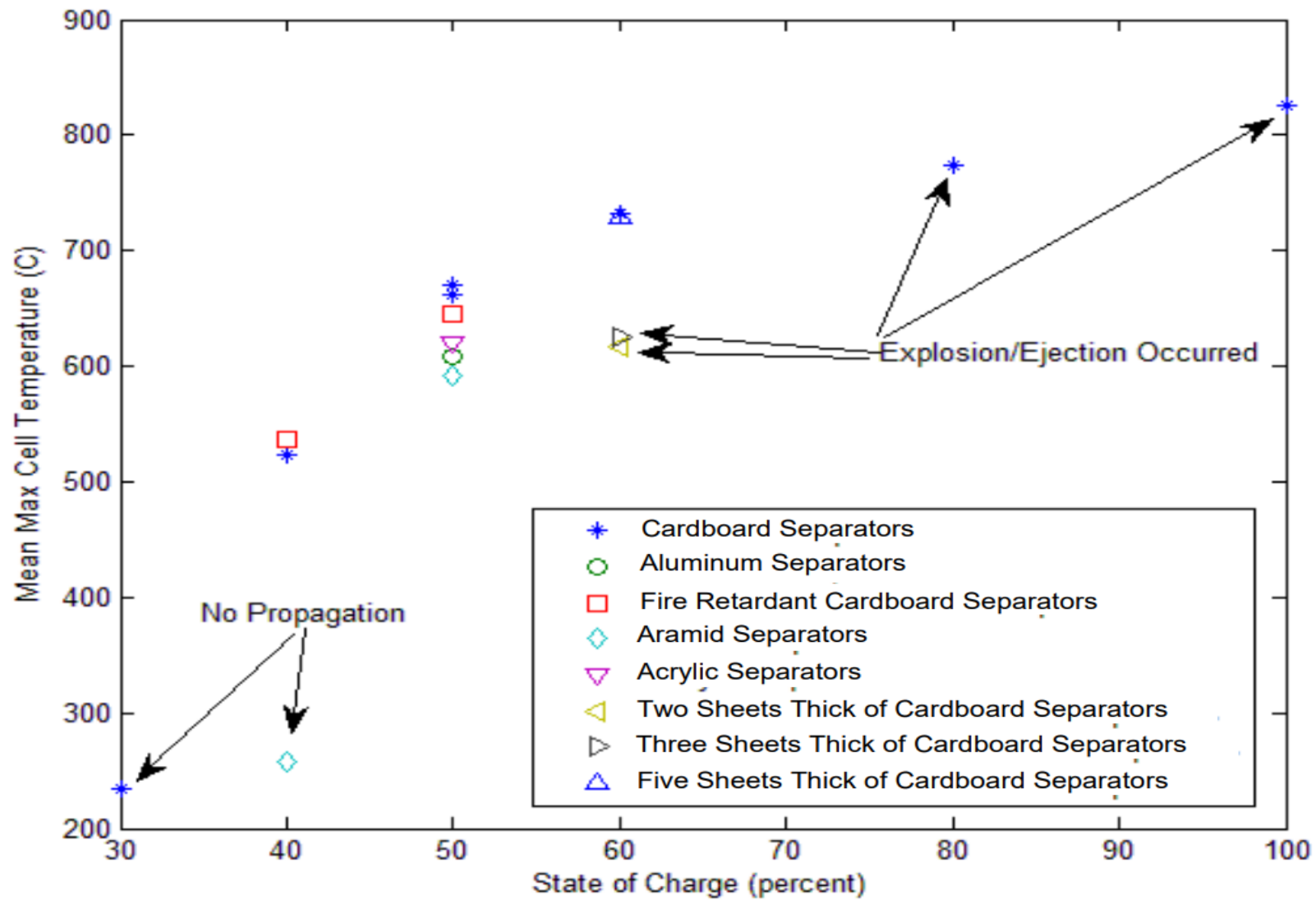

Figure 49. Average of the maximum of the cells in the tests

QUESTIONS?

