



ICAO

*International Civil Aviation Organization*THE FIFTH MEETING OF THE SURVEILLANCE  
STUDY GROUP (SURSG/5)*(Bangkok, Thailand, 23-24 March 2026)***Agenda Item 2**

Review of the outcome of relevant meetings

**GUIDANCE MATERIAL TO ASSIST APANPIRG SUBSIDIARY GROUPS IN REVIEWING  
AND UPDATING THE LIST OF APAC COMMON SWIM INFORMATION SERVICES**

(Presented by SWIM TF)

**SUMMARY**

This paper requests APANPIRG Subsidiary Groups with subject matter expertise in relevant information domains to review and update/refine the details associated with APAC Common SWIM Information Services planned for future implementation in the region. Guidance material has been drafted by SWIM TF Task 6 experts to illustrate the level of detail that is requested.

**1. INTRODUCTION**

1.1 Decision 36/11 from APANPIRG/36 in November 2025 adopted the [First Version of the Business Functionality for APAC Common SWIM Information Services](#), and was published on the ICAO APAC eDocuments site. SWIM TF acknowledges and appreciates the efforts and inputs from the APANPIRG Subsidiary Groups in achieving this important first milestone in providing guidance for planning and implementing SWIM information services in the APAC Region.

1.2 At SWIM TF/10 in May 2025, it was noted that the level of detail differed across different information domains (e.g., aeronautical information, flight information, surveillance data, meteorological information, etc.), potentially caused by different levels of understanding as to what detail is needed by SWIM TF to facilitate the development of SWIM information services within the APAC Region.

1.3 This Working Paper requests APANPIRG Subsidiary Groups with relevant information domain knowledge to review and update/refine the business functionality for APAC Common SWIM Information Services to initiate the development of the Second Version of the APAC Common SWIM Information Services document, through the provision of Guidance Material.

1.4 The provision of the Guidance Material is also intended to serve as the foundation for APANPIRG Subsidiary Groups to regularly review the APAC Common SWIM Information Services document and provide updates to SWIM TF as necessary to maintain the currency of the list relevant to their respective information domain.

## 2. DISCUSSION

2.1 Guidance Material to assist APANPIRG Subsidiary Groups in reviewing and updating the list of APAC Common SWIM Information Services is provided in **Appendix A**. Specifically, it provides guidance on the type and level of detail requested for:

- a) Business functionality of the Information Service;
- b) Brief description of the service;
- c) Type of information to be exchanged;
- d) Information exchange model / Message type;
- e) Message exchange pattern; and
- f) Priority.

2.2 The Guidance Material also provides a worked example reflecting updates that could be made to some entries based on the enclosed guidance. The worked example is indicative only and does not reflect the actual changes that may be proposed for those Information Services by the relevant information domain experts.

2.3 Subsidiary Groups are also invited to review whether the existing description of business functionality of information service per row of the list covers more than one business function and consider the need to break down the existing ones further into multiple specific information services at a higher level of detail as appropriate with more focused description. Each entry of the information service should be at a sufficient level of detail to facilitate the implementation of a single common SWIM information service per description.

2.4 A new working version (draft Second Version) of the Business Functionality for APAC Common SWIM Information Services is provided in **Appendix B**. APANPIRG Subsidiary groups are requested to use the provided Guidance Material and use “track changes” in this document to submit any proposed updates to SWIM TF. The proposed updates submitted by the groups will be collated into a WP for submitting the draft Second Version to the SWIM TF/11 scheduled for 26-29 May 2026.

2.5 SWIM TF welcomes suggested improvements to the usability/clarity/structure of the information in the list of APAC Common SWIM Information Services. Two potential changes have already been identified by SWIM TF for consideration for future updates:

- a) Introduction of “applicability” (e.g., “region-wide” in order to achieve the anticipated benefits, vs. “as needed” to meet local needs); and
- b) Addition of desired implementation timeframe (e.g., immediate (before 2030), medium-term (2030-2035), and long-term (beyond 2035)).

2.6 SWIM TF also recommends APANPIRG Subsidiary Groups regularly review the APAC Common SWIM Information Services document each time they meet and submit updates to SWIM TF as necessary to maintain the currency of the list relevant to their respective information domain.

2.7 It was also agreed that this guidance material will be submitted to all relevant groups under APANPIRG to get feedback on the document and share information about the expectations from the list of APAC common SWIM information services.

2.8 This paper was presented to the Fourth Asia/Pacific FF-ICE Ad-Hoc Group Meeting and Workshop, held from 16 to 18 March 2026. The Ad-hoc Group reviewed the Business Functionality of APAC Common SWIM Information Services, Version 1.0, and agreed on the following recommendations for consideration by the ICAO APAC SWIM Task Force (SWIM TF).

1. Recognizing the limited technical expertise within domain-specific groups such as the FF-ICE Ad-Hoc Group, it was agreed that the group should **focus on defining business rules and business process completion criteria** for information services. The determination of appropriate Message Exchange Patterns (MEPs) for each business process should be undertaken by SWIM TF, which possesses the relevant technical expertise.
2. To support the determination of MEPs, it was agreed that **comprehensive operational scenarios**, including operational requirements and business process completion criteria, are essential. Accordingly, such scenarios, where required, should be provided as an appendix to the Business Functionality of APAC Common SWIM Information Services document. A reference to the appendix should also be included in the ‘Brief description of the service’ column. Figure 1 illustrates an example of how these comprehensive scenarios may be incorporated:

Business functionality of the information service	Brief description of the service	Type of information to be exchanged	Information exchange model / Message type	Message exchange pattern	Priority of Recommended Service in Initial APAC Common SWIM-IS (1) / (2) / (3)
FF-ICE filing service	Provides a means to submit, update or cancel flight plans through a SWIM-based interface using FIXM. <b>Appendix A: Filing Scenario</b>	Flight plan for registration, update or cancellation	FIXM	Appendix A	1

SWIM TF to fill in

**Appendix A: Filing Scenario**

	Message	Details	Timeout	Comments	Message Exchange Pattern
1	eAU send eFPL (FFP) to eASP	Mandatory	N/A	-	
2	eASP returns Submission Response (SR) #1 to eAU	Mandatory (after eFPL received)	1 minute	eASPs validate message format and basic rules. SR ACK: Validation passed SR REJ: Validation failed SR MAN: Manual Processing needed	
3	eASP returns Submission Response (SR) #2 to eAU	Conditional (only if SR#1 = MAN)	Variable (manual processing time)	Any subsequent SR is provided after manual intervention of eFPL (after SR MAN)	
4	eASP returns Filing Status (FS) #1 to eAU	Mandatory (if final SR = ACK)	1 minute after SR “ACK”	eASPs evaluate flight plan against operational constraints and ATM configuration	
5	eASP returns Filing Status (FS) #2 to eAU	Conditional (if FS #1 = PENDING, or due to re-evaluation)	Variable (2 <sup>nd</sup> evaluation)	eASP sends updated FS when flight is ready to be evaluated (for PENDING) or when operational changes affect flight status	

Figure 1: An example of how the comprehensive scenarios may be incorporated in the Business Functionality of APAC Common SWIM Information Services.

2.9 The feedback submitted by FF-ICE/4 will be reviewed by the SWIM TF/10 Meeting in May 2026.

**3. ACTION BY THE MEETING**

3.1 The meeting is invited to:

- a) note the information contained in this paper;
- b) review and update/refine the relevant entries of the APAC Common SWIM Information Services document relevant to the information domain of the meeting for submission back to SWIM TF (paragraph 2.4 refers); and

- c) consider the review of the APAC Common SWIM Information Services document as a standing meeting agenda item for future meetings and subsequent update to SWIM TF, as both SWIM and the associated required Information Services continue to evolve regionally and globally.

-----



# Guidance Material for Business Functionality of APAC Common SWIM Information Services

Developed by: SWIM Task Force (Task 6)



## Purpose

- This Guidance Material has been developed to assist relevant APANPIRG Subsidiary Groups (e.g. MET/IE, SURICG, AAITF, FF-ICE Ad Hoc Group, ATFM SG) in specifying the relevant information associated with the high-level definition of planned APAC Common SWIM Information Services
  - Version 1 of the APAC Common SWIM Information Services has recently been published on the ICAO APAC eDocs site as per Decision APANPIRG/36/11:  
<https://www.icao.int/sites/default/files/APAC/Documents/edocs/CNS/APAC-Common-SWIM-Information-Services.pdf>
  - The purpose of list of APAC Common SWIM Information Services (including associated priorities) is to provide States/Administrations with **guidance on anticipated services to support their planning and implementation** of SWIM
    - Listed Information Services are expected to be at different levels of maturity, i.e. are not expected to be fully matured prior to being added to the list as an indicative roadmap for the Information Service
    - It is not intended to be overly prescriptive
      - This information will be captured in the Information Service Definitions (ISD)



## Version Maintenance

- The latest published version of the Common APAC SWIM Information Services is available on the ICAO APAC eDocs site (CNS section)
- Between published versions, SWIM TF maintains an updated working version of Information Services to capture inputs from the APANPIRG Subsidiary Groups as they occur
  - APANPIRG Subsidiary Groups are recommended to regularly review/update the APAC Common SWIM Information Services document each time they meet, and to provide updates to SWIM TF as necessary to maintain the currency of the list relevant to their information domain (e.g. Aeronautical Information, Flight information, Meteorological information)
  - Between published versions, SWIM TF will update the working list at SWIM TF meetings based on inputs from Subsidiary Groups
    - The latest working version will be available following finalisation of each SWIM TF Report



## Categories

- The Categories associated with the Business Functionality of APAC Common SWIM Information Services are:
  - Business Functionality of the information service
  - Brief description of the service
  - Type of information to be exchanged
  - Information exchange model / Message type
  - Message exchange pattern
  - Priority
- Guidance on each Category is provided in the following slides



# Business functionality of the information service

Business functionality of the information service	Brief description of the service	Type of information to be exchanged	Information exchange model / Message type	Message exchange pattern	Priority (1) / (2) / (3)
---	----------------------------------	-------------------------------------	---	--------------------------	--------------------------

- **What the Information Service is called**
  - **Wherever possible**, this should align with Information Services that are being implemented globally, defining APAC regional variations only where needed
    - e.g. FF-ICE filing service
  - It may be prudent (even advisable) to define **different information services** where the **same information** is provided in the payload, but which may serve a **different business need** (i.e. be utilised by different consumers of the information services at a different rate or have a different Quality of Service)
    - E.g. An information service providing surveillance data to support the provision of aircraft separation could be expected to be defined separately to an information service providing surveillance data to support ATFM purposes, as the business usage differs between the two information services



## Brief description of the service (1)

Business functionality of the information service	Brief description of the service	Type of information to be exchanged	Information exchange model / Message type	Message exchange pattern	Priority (1) / (2) / (3)
---	----------------------------------	-------------------------------------	---	--------------------------	--------------------------

- **Plain text description of the information service**
  - Includes **Intended usage** of the information service
    - Includes indication (where relevant) of the intended service consumers and/or associated business need
  - Includes **Identification of** (and link to) the **latest reference document** (where one exists)
    - Provides insight/clarity on how the intended information service is aligning with global or regional concepts/implementations
      - E.g. For FF-ICE filing service, **ICAO Doc 9965 (Manual on FF-ICE)**
      - E.g. for Surveillance data only sharing service, **Guidance Materials for the sharing of surveillance data in SWIM** developed by SURSG
    - As maturity increases over time, the document reference will change
      - **Goal** is to reference the relevant Information Service Description (ISD) once developed



## Brief description of the service (2)

Business functionality of the information service	Brief description of the service	Type of information to be exchanged	Information exchange model / Message type	Message exchange pattern	Priority (1) / (2) / (3)
---	----------------------------------	-------------------------------------	---	--------------------------	--------------------------

- **Plain text description of the information service**

- The description of the information service should include proposed timeframe for implementation
  - Note: proposed implementation timing may be moved to a separate column in a future update of the table
- The description of the information service should **not** include:
  - Proposed timeframe for implementation (this is proposed to be captured in a future update to the table)
  - Reference to the Information Exchange Model (e.g. FIXM)
  - Information to be exchanged (captured in the “information to be exchanged” column)



# Type of information to be exchanged

Business functionality of the information service	Brief description of the service	Type of information to be exchanged	Information exchange model / Message type	Message exchange pattern	Priority (1) / (2) / (3)
---	----------------------------------	-------------------------------------	---	--------------------------	--------------------------

- **The information that will be exchanged as part of the information service**
  - Describes the information in general terms only (rather than individual data elements)
    - E.g. Surveillance data with DAPs, Basic flight plan information (without trajectory), etc.
  - The ISD (once developed) will specify all mandatory and optional fields
    - Subsidiary groups may need to separately develop this additional granularity if the information service has not already been defined elsewhere
  - Timeframes for transitioning information types should not be included



# Information exchange model / message type

Business functionality of the information service	Brief description of the service	Type of information to be exchanged	Information exchange model / Message type	Message exchange pattern	Priority (1) / (2) / (3)
---	----------------------------------	-------------------------------------	---	--------------------------	--------------------------

- **The information exchange model (or message type) employed by the payload of the information service**
  - Identifies standard Exchange Models (FIXM, IWXXM, AIXM)
    - E.g. (FIXM, IWXXM, AIXM)
  - Where the content within the payload comes from another message type or data format, this can be identified
    - E.g. Surveillance data: JSON or RAW (derived from ASTERIX Cat 21)
  - Version / associated extensions of the Exchange Model is not required
  - If not yet known or confirmed, “TBD” is acceptable



# Message exchange pattern (1)

Business functionality of the information service	Brief description of the service	Type of information to be exchanged	Information exchange model / Message type	Message exchange pattern	Priority (1) / (2) / (3)
---	----------------------------------	-------------------------------------	---	--------------------------	--------------------------

- **The type of information that will be exchanged as part of the information service**
  - **At least one of:**
    - Request/Reply (**Req/Rep**), including type if known (see additional information on following slides)
      - Synchronous Request/Reply (**Sync R/R**)
      - Asynchronous Request/Reply (**Async R/R**)
    - Fire and Forget (**One-way**)
    - Publish/Subscribe (**Pub/Sub**)
  - If multiple MEPs are possible, identify which are mandatory or optional
    - E.g. Pub/Sub and Sync R/R
    - E.g. Req/Rep (mand), Req/Rep (opt), etc.
  - **“TBD” to be used where MEP is not yet known**



# Fire and Forget vs. Publish / Subscribe

Business functionality of the information service	Brief description of the service	Type of information to be exchanged	Information exchange model / Message type	Message exchange pattern	Priority (1) / (2) / (3)
---	----------------------------------	-------------------------------------	---	--------------------------	--------------------------

From the ICAO Manual on the SWIM Implementation (Doc 10203):

- For the **One-way (“Fire and Forget”) MEP**, the consumer initiates a message to an information service without expecting any response from the information service. This MEP is particularly useful at the lower application layer, where immediate message responses are not required;
- For the **Publish/Subscribe MEP**, the consumer initiates a subscription request to an information service. The subscription may be capable of providing details (such as through a filtering parameter) on the information being subscribed
- The P/S MEP can be either a ‘push’ or a ‘pull’ mechanism:
  - For the ‘push’ mechanism, this requires that the consumer can receive messages at any time, and is not restricted from completing other operations while waiting for the Information Service to respond
  - For the ‘pull’ mechanism, this requires the Information Service to keep necessary updates available to the consumer, and that the consumer sends requests to the information service to receive the updates

# Synchronous Request-Reply

Business functionality of the information service	Brief description of the service	Type of information to be exchanged	Information exchange model / Message type	Message exchange pattern	Priority (1) / (2) / (3)
---	----------------------------------	-------------------------------------	---	--------------------------	--------------------------

In Doc. 10203, **synchronous** R/R MEP is defined as – *The consumer initiates a request to an information service; the service processes the request and generates a reply to the consumer. The consumer waits for the information service to provide a response. During this waiting period, the consumer cannot send or receive any other requests or responses. This pattern is specifically applicable to information services that can quickly execute and respond to consumer requests*

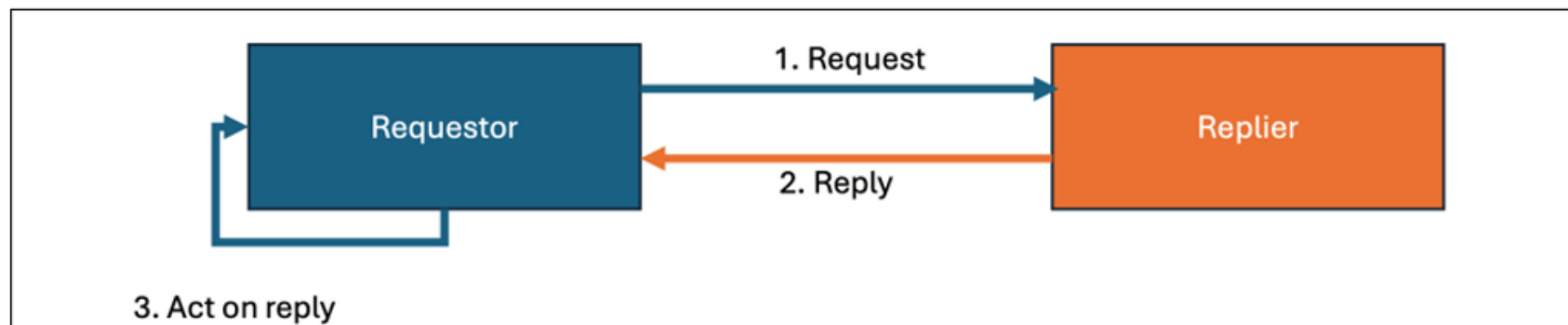

# Asynchronous Request-Reply

Business functionality of the information service	Brief description of the service	Type of information to be exchanged	Information exchange model / Message type	Message exchange pattern	Priority (1) / (2) / (3)
---	----------------------------------	-------------------------------------	---	--------------------------	--------------------------

In Doc. 10203, **asynchronous** R/R MEP is defined as – *The consumer initiates a request to an information service; the service processes the request and generates a reply to the consumer. However, the consumer is not restricted from performing other operations while waiting for the information service’s response. This MEP requires that the consumer be able to receive messages at any time and correlate them with prior requests*

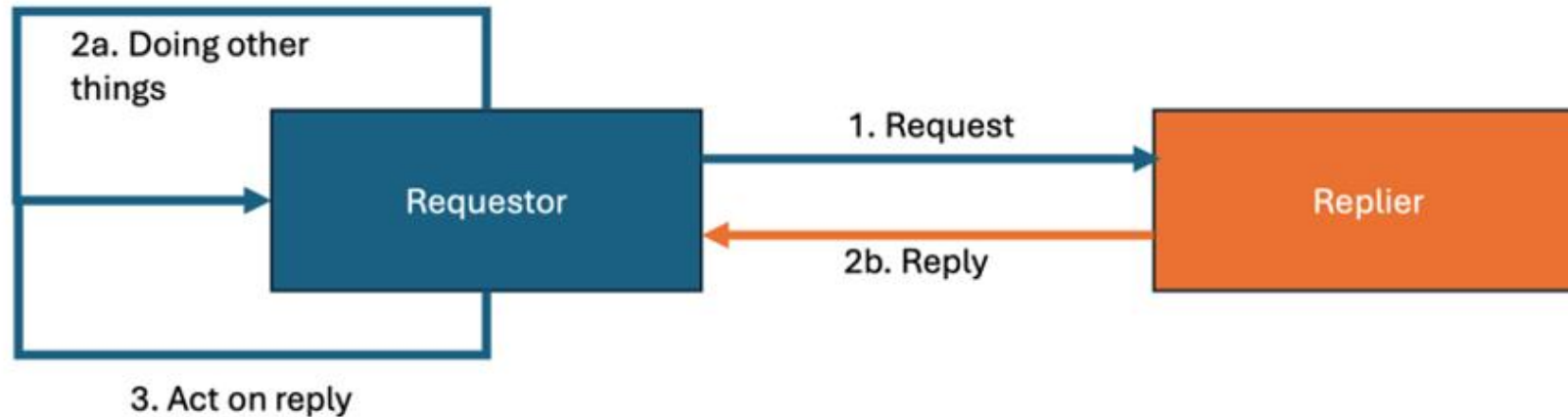



# Synchronous vs. Asynchronous Request-Reply

Business functionality of the information service	Brief description of the service	Type of information to be exchanged	Information exchange model / Message type	Message exchange pattern	Priority (1) / (2) / (3)
---	----------------------------------	-------------------------------------	---	--------------------------	--------------------------

Index	Synchronous	Asynchronous
Time Coupling	Both requester and replier are available at the same time.	Requester sends a request and continues its process; replier can send the response later when available.
Space Coupling	Requester needs to know the exact service endpoint (protocol, address, API).	Requester sends to a known endpoint, but response may arrive via callback, polling, or correlation ID; looser coupling in response handling.
Reliability Handling	Retries and error handling happen at requestor side.	Retries and correlation of delayed responses must be managed at the requester side (e.g., matching reply with original request).
Use Cases	<ul style="list-style-type: none"> <li>• Low latency expected</li> <li>• Both parties are available</li> <li>• Immediate response interaction</li> </ul>	<ul style="list-style-type: none"> <li>• Replier may not be immediate</li> <li>• Deferred or background processing acceptable</li> </ul>
Typical Scenarios	<ul style="list-style-type: none"> <li>• User Authentication</li> <li>• User Interface Interactions</li> <li>• Database Read and Immediate Write</li> </ul>	<ul style="list-style-type: none"> <li>• Order processing with delayed confirmation</li> <li>• Flight plan filing with later validation</li> <li>• Weather data request with queued response</li> <li>• Batch data processing</li> </ul>

– Additional guidance can be found in “**Draft Guidance Material REQ REP MEP in Asia**” provided as **Appendix C** to the Working Paper

- If in doubt:
- Specify Req/Rep only
  - Leave as TBD



## Priority (1) / (2) / (3)

Business functionality of the information service	Brief description of the service	Type of information to be exchanged	Information exchange model / Message type	Message exchange pattern	Priority (1) / (2) / (3)
---	----------------------------------	-------------------------------------	---	--------------------------	--------------------------

- **Either 1, 2 or 3 as determined by:**
  - Priority (1): Recommended for region-wide implementation for region-wide benefits
  - Priority (2): Recommended for implementation as much as practicable
  - Priority (3): Additional information services without common regional requirements and not included as a part of common regional information services
- *Note: It has been proposed to separate applicability (region-wide vs. as needed by a subset of States) and desired timeframe into separate columns, however any change to table columns will be formally communicated to Subsidiary Groups separately*



## Example update

Note: this is not an actual update, it has been provided to indicate *potential* updates to FF-ICE Common APAC SWIM Information Services content that would align with this Guidance Material



## Example – FF-ICE Information Services - Current

Business functionality of the information service	Brief description of the service	Type of information to be exchanged	Information exchange model / Message type	Message exchange pattern	Priority (1) / (2) / (3)
APAC Common SWIM Flight Information Services					
GUFI service	GUFI (Globally Unique Flight Identifier) generation and provision	GUFI	FIXM	Req/Reply	1
FF-ICE filing service	Provides a means to submit, update or cancel flight plans through a SWIM-based interface using FIXM.	Flight plan for registration, update or cancellation	FIXM	Req/Reply Pub/Sub	1
FF-ICE publication service	Provides harmonised sharing of flight plan information in a global standard supporting common situation awareness.	Flight information for publication	FIXM	Pub/Sub	2
FF-ICE trial service	Allows operators to test the effect of a potential change in a flight plan prior to committing to the change.	Proposed changes in a flight plan	FIXM	Req/Reply	2
FF-ICE flight data request service	Allows an operator to request the current status of a flight plan, or an ANSP can request an operator to submit the latest version of their flight plan.	Current status of a flight plan, a copy of flight plan or supplementary plan	FIXM	Req/Reply	1
FF-ICE notification service	Provides notification of a change in flight state, such as Departure (DEP) and Arrival (ARR) Air Traffic Service (ATS) messages.	ARR, DEP messages	FIXM	Req/Reply Pub/Sub	1
FF-ICE planning service	Allows operators to submit preliminary flight plans for early Air Traffic Flow Management (ATFM) planning and to obtain feedback regarding restrictions/constraints affecting the flight.	Preliminary flight plan for early ATFM planning	FIXM	Req/Reply Pub/Sub	2



## Example – FF-ICE Information Services – *Potential* updates

Business functionality of the information service	Brief description of the service	Type of information to be exchanged	Information exchange model / Message type	Message exchange pattern	Priority (1) / (2) / (3)
FF-ICE filing service	Provides a means <u>for Airspace Users</u> to submit, update or cancel flight plans <u>through a SWIM based interface using FIXM</u> . <u>Reference: ICAO Doc 9965 (Manual on FF-ICE)</u> <u>Target Implementation timeframe 2034</u>	<u>Full Flight plan with trajectory for registration, update or cancellation</u>	FIXM	<u>Req/Reply</u> <u>Async R/R</u> <u>and Pub/Sub</u>	1
FF-ICE publication service	Provides <u>harmonised sharing of</u> flight plan information in a <u>global standard format</u> supporting common situation awareness. <u>Reference: ICAO Doc 9965 (Manual on FF-ICE)</u>	<u>Flight information for publication Full Flight Plan with trajectory (latest agreed)</u>	FIXM	Pub/Sub	2
FF-ICE trial service	Allows operators to test the effect of a potential change in a flight plan prior to committing to the change. <u>Reference: ICAO Doc 9965 (Manual on FF-ICE)</u>	Proposed changes in a flight plan	FIXM	<u>Req/Reply</u> <u>Sync R/R</u> <u>and</u> <u>Async R/R</u>	2
FF-ICE flight data request service	Allows an operator to request the current status of a flight plan, or an ANSP can request an operator to submit the latest version of their flight plan. <u>Reference: ICAO Doc 9965 (Manual on FF-ICE)</u> <u>Target Implementation timeframe 2034</u>	Current status of a flight plan, <u>or a copy of full flight plan, or supplementary plan</u>	FIXM	<u>Req/Reply</u> <u>Sync R/R and</u> <u>Async R/R</u>	1
FF-ICE notification service	Provides notification of a change in flight state, such as Departure (DEP) and Arrival (ARR) Air Traffic Service (ATS) messages. <u>Reference: ICAO Doc 9965 (Manual on FF-ICE)</u>	<u>ARR, DEP messages</u> <u>Movement information (e.g. ARR, DEP)</u>	FIXM	<u>Req/Reply</u> <u>Pub/Sub</u> <u>and</u> <u>Sync R/R</u> <u>and</u> <u>Async R/R</u>	1
FF-ICE planning service	Allows operators to submit preliminary flight plans for early Air Traffic Flow Management (ATFM) planning and to obtain feedback regarding restrictions/constraints affecting the flight. <u>Reference: ICAO Doc 9965 (Manual on FF-ICE)</u>	Preliminary <u>full flight plan with trajectory for early ATFM planning</u>	FIXM	<u>Req/Reply</u> <u>Async R/R</u> <u>and Pub/Sub</u>	2



## Suggested Improvements?

- **SWIM TF is open to improving usability/clarity of information within the table of APAC Common SWIM Information Services prior to publishing the next version**
- **For the next version, SWIM TF is already considering a proposal:**
  - To replace “Priority” column with:
    - Applicability: region-wide (to achieve anticipated benefits) vs. as needed (to meet local needs), and
    - Desired implementation timeframe (e.g. immediate (before 2030), medium (2030-2035), longer term)
- **SWIM TF invites Subsidiary Groups to provide suggestions ahead of SWIM TF/11 in May 2026 for consideration for incorporation into the next version**
  - SWIM TF thanks you in advance for any suggestions



# Suggested Improvements – FF-ICE/4

- **FF-ICE/4 (16-18 March 2026) has additionally recommended the following:**
  1. **Subsidiary Groups should focus on defining business rules and business process completion criteria for Information Services. FF-ICE/4 recommended SWIM TF should undertake the determination of the appropriate Message Exchange Patterns (MEPs) for each business process, as SWIM TF possesses the relevant technical expertise**
  2. **FF-ICE/4 noted that comprehensive operational scenarios, including operational requirements and business process completion criteria, are essential. Accordingly, such scenarios, where required, should be provided as an appendix to the Business Functionality of APAC Common SWIM Information Services document. A reference to the appendix should also be included in the ‘Brief description of the service’ column, as illustrated below:**

Business functionality of the information service	Brief description of the service	Type of information to be exchanged	Information exchange model / Message type	Message exchange pattern	Priority of Recommended Service in Initial APAC Common SWIM-IS (1) / (2) / (3)
FF-ICE filing service	Provides a means to submit, update or cancel flight plans through a SWIM-based interface using FIXM. <b>Appendix A: Filing Scenario</b>	Flight plan for registration, update or cancellation	FIXM	<b>Appendix A</b>	1

**Appendix A: Filing Scenario**

	Message	Details	Timeout	Comments	Message Exchange Pattern
1	eAU send eFPL (FFP) to eASP	Mandatory	N/A	-	
2	eASP returns Submission Response (SR) #1 to eAU	Mandatory (after eFPL received)	1 minute	eASPs validate message format and basic rules. SR ACK: Validation passed SR REJ: Validation failed SR MAN: Manual Processing needed	
3	eASP returns Submission Response (SR) #2 to eAU	Conditional (only if SR#1 = MAN)	Variable (manual processing time)	Any subsequent SR is provided after manual intervention of eFPL (after SR MAN)	

SWIM TF to fill in





| ICAO

CAPACITY & EFFICIENCY

## Reference

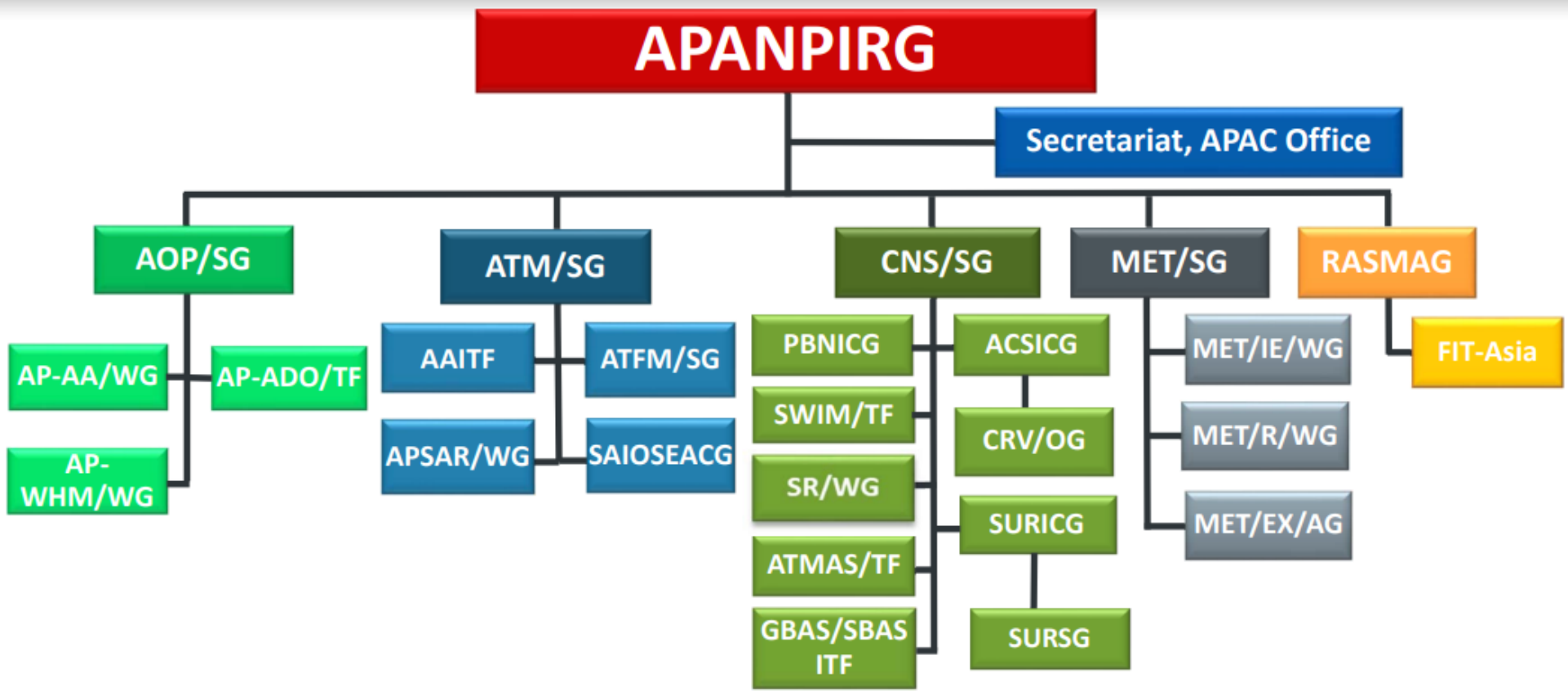

**AOP/SG** - Aerodrome Operations and Planning Sub Group  
**AP-AA/WG** - APAC Aerodrome Assistance Working Group  
**AP-ADO/TF** - APAC Aerodrome Design and Operations Task Force  
**AP-WHM/WG** - APAC Wildlife Hazard Management Working Group

**ATM/SG** - ATM Sub Group  
**AAITF** - AIS - AIM Implementation Task Force  
**APSAR/WG** - APAC Search and Rescue Working Group  
**ATFM/SG** - ATFM Steering Group  
**SAIOSEACG** - South Asia Indian Ocean and South East Asia ATM Coordination Group

**CNS/SG** - CNS Sub Group  
**PBNICG** - PBN Implementation Coordination Group  
**SWIM/TF** - System-Wide Information Management Task Force  
**SR/WG** - Spectrum Review Working Group  
**ATMAS/TF** - ATM Automation System Task Force  
**GBAS/SBAS ITF** - GBAS/SBAS Implementation Task Force  
**ACSICG** - Aeronautical Communication Services Implementation Coordination Group  
 • **CRV/OG** - Common Regional Virtual Private Network (VPN) Operations Group  
**SURICG** - Surveillance Implementation Coordination Group  
 • **SURSG** - Surveillance Study Group

**MET/SG** - Meteorology Sub Group  
**MET/IE/WG** - Meteorological Information Exchange Working Group  
**MET/R/WG** - Meteorological Requirements Working Group  
**MET/EX/AG** - Meteorological Exercises Advisory Group

**RASMAG** - Regional Airspace Safety Monitoring Advisory Group  
 • **FIT-ASIA** - FANS Interoperability Team-Asia

**Business Functionality of APAC Common SWIM Information Services**  
(Updated by **XXXX**)

**Draft Second Version (xx 2026)**

*Purpose.*– This list of APAC Common SWIM Information Services, including associated priorities, provides States/Administrations with guidance on anticipated services to support their planning and implementation of SWIM.

*Notes.*– Priority of Recommended Services in Initial APAC Common SWIM Information Service (IS) ((1)/(2)/(3)):

- Priority (1): Recommended for region-wide implementation for region-wide benefits
- Priority (2): Recommended for implementation as much as practicable
- Priority (3): Additional information services without common regional requirements and not included as a part of common regional information services

Business functionality of the information service	Brief description of the service	Type of information to be exchanged	Information exchange model / Message type	Message exchange pattern	Priority (1) / (2) / (3)
APAC Common SWIM Aeronautical Information Services					
Airspace management service	Exchanges of airspace status information between ASM Support System and Air Traffic Control (ATC) System. The sharing of airspace availability and airspace structure in real-time will contribute to a more efficient execution of the flight as information impacting the trajectory will be exchanged.	Availability or activation/deactivation or temporarily change of airspace, restricted area, danger area, search and rescue regions	AIXM	Pub/Sub or Req Reply	2
Airspace feature service	Provides the characteristics of the three-dimensional airspace, described as horizontal projection with vertical limits, and their relevance to air traffic.	FIR/UIR boundaries, waypoints, enroute ATS routes, SIDs and STARs, nav aids, procedures, and other airspace not limited to restricted area, prohibited area, danger area, search and rescue regions	AIXM	Pub/Sub or Req Reply	2

Business functionality of the information service	Brief description of the service	Type of information to be exchanged	Information exchange model / Message type	Message exchange pattern	Priority (1) / (2) / (3)
		(Remarks – Other data published in the AIP may be included)			
Aerodrome feature service	Provides current and/or planned airport layout features, such as aerodrome mapping data, runway, taxiway, passenger facilities.	Runways, movement areas, aerodrome services, nav aids, instrument landing systems, Aerodrome location, communication facilities (frequencies)	AIXM	Pub/Sub or Req Reply	2
Runway Condition Report service	Provides runway surface conditions and contaminants (least to most slippery) that are directly correlated to aircraft take-off and landing performance.	Global Reporting Format (GRF) for runway surface conditions	AIXM	Pub/Sub or Req/Reply	2
Digital NOTAM distribution service	Provides aeronautical information in accordance with the Digital NOTAM Specification, such as runway closure.	Digital NOTAM (e.g. Special activity airspace (SAA) NOTAMs, or other types of NOTAMs)	AIXM	Pub/Sub or Req Reply	2
ATIS distribution service	Provides continuous and automated broadcast of recorded aeronautical information in airport and terminal areas.	Current weather conditions, runway in use, available approaches, and other data relevant to arriving and departing aircraft, specific ATC procedures, and any airport construction activity that could affect taxi planning	TBD	Pub/Sub	3
Search and rescue service	Allows Rescue Coordination Centres (RCCs) to exchange information with neighbouring RCCs and ATS units for coordination during SAR operations.	Search and rescue regions, Registered aircraft operator details and contacts, ICAO Autonomous Distress Tracking (ADT) data, Location of Aircraft in Distress Repository (LADR) data, ICAO OPS CTRL database contact information, SAR Unit (SRU) location and capability data	TBD	Pub/Sub	3

<b>Business functionality of the information service</b>	<b>Brief description of the service</b>	<b>Type of information to be exchanged</b>	<b>Information exchange model / Message type</b>	<b>Message exchange pattern</b>	<b>Priority (1) / (2) / (3)</b>
APAC Common SWIM Flight Information Services					
GUFI service	GUFI (Globally Unique Flight Identifier) generation and provision	GUFI	FIXM	Req/Reply	1
FF-ICE filing service	Provides a means to submit, update or cancel flight plans through a SWIM-based interface using FIXM.	Flight plan for registration, update or cancellation	FIXM	Req/Reply Pub/Sub	1
FF-ICE publication service	Provides harmonised sharing of flight plan information in a global standard supporting common situation awareness.	Flight information for publication	FIXM	Pub/Sub	2
FF-ICE trial service	Allows operators to test the effect of a potential change in a flight plan prior to committing to the change.	Proposed changes in a flight plan	FIXM	Req/Reply	2
FF-ICE flight data request service	Allows an operator to request the current status of a flight plan, or an ANSP can request an operator to submit the latest version of their flight plan.	Current status of a flight plan, a copy of flight plan or supplementary plan	FIXM	Req/Reply	1
FF-ICE notification service	Provides notification of a change in flight state, such as Departure (DEP) and Arrival (ARR) Air Traffic Service (ATS) messages.	ARR, DEP messages	FIXM	Req/Reply Pub/Sub	1
FF-ICE planning service	Allows operators to submit preliminary flight plans for early Air Traffic Flow Management (ATFM) planning and to obtain feedback regarding restrictions/constraints affecting the flight.	Preliminary flight plan for early ATFM planning	FIXM	Req/Reply Pub/Sub	2

Business functionality of the information service	Brief description of the service	Type of information to be exchanged	Information exchange model / Message type	Message exchange pattern	Priority (1) / (2) / (3)
ADP Distribution Service	Supports publication and distribution of ATFM Daily Plan (ADP), based on information included in the APAC ADP Exchange Procedure <sup>1</sup> . The published ADP is designed to inform for stakeholders on upcoming demand/capacity constraints and possible ATFM measures.	Refer to ADP template	FLXM <sup>2?</sup>	Pub/Sub	1
Flight-Specific ATFM Measure Service	Supports notification of information related to “flight-specific” ATFM measures, i.e. measures whose control mechanisms apply to a single flight. An example is the Ground Delay Program (GDP), whose control mechanism is a Calculated Take-Off Time (CTOT), or an ATFM measure for airborne flight, whose control mechanism is a Calculated Time Over (CTO).  Recipients of this information should take actions to comply with the ATFM measure contained herein.	CTOT, CTO, CLDT, and fields currently included in <a href="#">APAC AFTN/AMHS-Based ICD for ATFM</a> <sup>3</sup>	FIXM	Req/Reply Pub/Sub	1
Flow-Specific ATFM Measure Service	Supports notification of information related to “flow-specific” ATFM measures, i.e. measures whose control mechanisms apply to a “group of flights” on a particular traffic flow. An example is the Minutes-in-Trail (MINIT) requirement applied on an eastbound traffic using A1 from VT*, VV* to RK*.	Spacing parameters for MINIT, MIT; Departure intervals for MDI; Alternate routes for Re-Routing; Flight level allocation for Level Capping	TBD	Pub/Sub	2 or 3

<sup>1</sup> The ADP template included herein is not updated. The new ADP template had been agreed by the AMNAC group and included into the [AMNAC COP v6.1](#), Appendix D, and was proposed to the ATFM/SG/15 (Apr-May 2025). The meeting agreed that the Secretariat will update the ADP Exchange Procedure to include the new template, which has already been supplied by AMNAC core team post-meeting.

<sup>2</sup> FLXM: Flow Information Exchange Model

<sup>3</sup> Based on the conclusion from ATFM/SG/15, an amendment to this ICD will be proposed in which a more structured use of REGUL and REGCAUSE fields will be introduced. This proposal is expected to be tabled at the upcoming CNS/SG meeting.

Business functionality of the information service	Brief description of the service	Type of information to be exchanged	Information exchange model / Message type	Message exchange pattern	Priority (1) / (2) / (3)
	Recipients of this information should take actions to comply with the ATFM measure contained herein. <sup>4</sup>				
ATFM/A-CDM Integration Service	Supports exchanges of flight-specific ATFM measure information and A-CDM milestone parameters among stakeholders, including arrival/departure ATFM units, airspace users, and airport operators, to integrate A-CDM process with ATFM operations.	ATFM measure information: CTOT  A-CDM departure planning information: TOBT, TTOT, TSAT	FIXM	Req/Reply Pub/Sub	1
APAC Common SWIM Meteorological Information Services					
FOR AERODROME					
METAR/SPECI service	Provides of IWXXM-formatted METAR/SPECI product specified in ICAO Annex 3.	Provision of the existing Annex 3 product via an information service	IWXXM	Pub/Sub Req/Reply	1
TAF service	Provides of IWXXM-formatted TAF product specified in ICAO Annex 3.		IWXXM	Pub/Sub Req/Reply	1
Aerodrome Meteorological Observation Information Service	Provides continuous observations of weather parameters at an aerodrome. Advanced meteorological SWIM (MET-SWIM) service being developed by MET Panel.	To be introduced as recommended practice in Annex 3 (Amd 84) in Nov 2030 tentatively (Note: Level of standardisation needs to be considered, as different aerodrome information services may be required for different use cases.)	IWXXM	Pub/Sub or Req/Reply	2*
Aerodrome Meteorological Forecast Information Service	Provides information of the expected meteorological conditions, including probability, at an airport during a specified period. Advanced meteorological SWIM (MET-SWIM) service being developed by MET Panel.		IWXXM	Pub/Sub or Req/Reply	2*
FOR ENROUTE					
SIGMET service	Provides IWXXM-formatted SIGMET product specified in ICAO Annex 3.	SIGMETs for thunderstorm, tropical cyclone, turbulence, icing, mountain wave, duststorm,	IWXXM	Pub/Sub Req/Reply	1

<sup>4</sup> Common operating procedure for this group of ATFM measures (e.g., MINIT, MIT, MDI, Re-Route, Level Capping) has not been developed for the APAC region yet, and should be developed before finalizing the information service to support the operations.

\* Will become Priority (1) when it is introduced as recommended practice in Annex 3 tentatively in Nov 2030

Business functionality of the information service	Brief description of the service	Type of information to be exchanged	Information exchange model / Message type	Message exchange pattern	Priority (1) / (2) / (3)
		sandstorm, volcanic ash and radioactive cloud			
AIRMET service	Provides IWXXM-formatted AIRMET product specified in ICAO Annex 3.	Provision of the existing Annex 3 product via an information service	IWXXM	Pub/Sub Req/Reply	2
Tropical Cyclone Advisory service	Provides IWXXM-formatted Tropical Cyclone Advisory product specified in ICAO Annex 3.  (Designated provider: States with Tropical Cyclone Advisory Centre)		IWXXM	Pub/Sub Req/Reply	1
Volcanic Ash Advisory service	Provides IWXXM-formatted Volcanic Ash Advisory product specified in ICAO Annex 3.  (Designated provider: States with Volcanic Ash Advisory Centre)		IWXXM	Pub/Sub Req/Reply	1
Space Weather Advisory service	Provides IWXXM-formatted Space Weather Advisory product specified in ICAO Annex 3.  (Designated provider: States with Space Weather Advisory Centre)		IWXXM	Pub/Sub Req/Reply	1
Volcano Observatory Notice for Aviation (VONA) service	Provides of IWXXM-formatted VONA specified in ICAO Annex 3. Provision of VONA is a recommended practice in Annex 3 (Amd 82).  (Designated provider: States with a designated State Volcano Observatory)		IWXXM	Pub/Sub Req/Reply	2
Quantitative volcanic ash concentration information (QVA) service	Provides detailed information of significant volcanic ash in the atmosphere, including probabilities of ash concentration thresholds over space and time. Advanced meteorological SWIM (MET-SWIM) service being developed by MET Panel.  (Designated provider: States with Volcanic Ash Advisory Centre (VAAC))		QVA gridded forecasts including probabilities, and IWXXM QVA objects. A recommended practice for significant ash clouds in Annex 3 (Amd 82) for VAACs in a position to do so from Nov 2025, and for all VAACs from Nov 2026.	Gridded data (e.g. NetCDF), IWXXM	Pub/Sub Req/Reply

<sup>#</sup> Will become Priority (1) from Nov 2026

Business functionality of the information service	Brief description of the service	Type of information to be exchanged	Information exchange model / Message type	Message exchange pattern	Priority (1) / (2) / (3)
WAFc (World Area Forecast Centres) gridded forecast service	Provides global gridded weather forecasts. (Designated provider: WAFcs (UK and US))	Global gridded forecasts of CB, icing, turbulence, upper winds, upper-air temperatures and humidity, flight level and temperature of tropopause, and direction, speed and flight level of maximum wind	Gridded data in GRIB2	Pub/Sub Req/Reply	1
WAFc significant weather (SIGWX) forecast service	Provides global WAFc SIGWX data sets with coverage expressed in polygons. (Designated provider: WAFcs (UK and US))	Significant weather forecast such as tropical cyclone, turbulence, icing, etc.	IWXXM	Pub/Sub or Req/Reply	1
Special Air Report (ARS) service	Provides reports of special observations made by aircraft when they encounter special weather phenomena, such as moderate/severe turbulence or icing. (Note: Currently there is no plan to implement this information service at MET Panel)	Special aircraft observations of weather phenomena as specified in Annex 3, including turbulence, icing, mountain wave, thunderstorms, duststorm, sandstorm, volcanic cloud, volcanic activity / eruption	TBD	Pub/Sub or Req/Reply	2
MET derived from Mode S DAPs service	Provides upper air winds and temperatures derived from Mode S Downlinked Aircraft Parameters (DAPs) (e.g. true airspeed, ground speed, magnetic heading, true track angle) and facilitates exchange of derived winds and temperatures among MET service providers.	Upper air winds and temperatures derived from Mode S DAPS	TBD	Pub/Sub or Req/Reply	3
Satellite image service	Provides satellite observational information.	Satellite derived MET information (e.g. significant convection)	Gridded format (e.g. NetCDF) and image format	Req/Reply	2
Weather radar image service	Provides two- or three-dimensional radar observational information.	Weather radar reflectivity to visualise the intensity of convection	Gridded format (e.g. NetCDF) and image format	Req/Reply	2

Business functionality of the information service	Brief description of the service	Type of information to be exchanged	Information exchange model / Message type	Message exchange pattern	Priority (1) / (2) / (3)
APAC Common SWIM Surveillance Information Services					
Surveillance data only sharing service	Provides surveillance data of aircraft.	latitude, longitude, flight level, ground speed (optional), magnetic heading (optional), target identification, target address, mode 3/A code (optional), date, time of message reception for position, quality indicators, SAC, SIC	ASTERIX Cat 21 (payload in JSON or RAW format)	Pub/Sub	1
Surveillance data with flight plan information sharing service	Provides surveillance data of aircraft with flight plan information.	globally unique flight identifier, aircraft identification, departure aerodrome, destination aerodrome, aircraft type (optional), wake turbulence category (optional) latitude, longitude, flight level, ground speed (optional), magnetic heading (optional), target identification, target address, mode 3/A code (optional), date, time of message reception for position, quality indicators, SAC, SIC	ASTERIX Cat 21+FPL (payload in JSON or RAW format)	Pub/Sub	2

Draft Guidance Materials for  
Request and Reply Message  
Exchange Pattern in Asia/Pacific  
SWIM

Oct. 2025

## Table of Contents

1.	Introduction .....	1
1.1.	Background .....	1
1.1.1.	SWIM Implementation Pioneer Ad-hoc Group (SIPG) .....	1
1.1.2.	Limitation of the Previous SWIM Efforts in the Asia/Pacific Region.....	1
1.2.	Guidance Materials .....	2
1.3.	Purpose of the Document.....	2
2.	Operational Concept.....	2
2.1.	Definition of R/R MEP .....	2
2.2.	Components of R/R MEP.....	2
3.	R/R MEP in SWIM.....	3
3.1.	R/R MEP in the Global Level .....	3
3.2.	R/R MEP in the Asia/Pacific Region.....	4
4.	Mechanism.....	4
4.1.	Synchronous R/R MEP.....	5
4.2.	Asynchronous R/R MEP.....	5
4.3.	Comparison of Synchronous and Asynchronous R/R MEP .....	5
4.4.	Confusion between Synchronous and Asynchronous R/R MEP .....	6
4.5.	Clarification of Synchronous and Asynchronous R/R MEP .....	7
5.	Implementation .....	8
5.1.	Implementation of Synchronous R/R MEP .....	8
5.2.	Implementation of Asynchronous R/R MEP .....	9
5.3.	Approach on Implementation of R/R MEP in Asia/Pacific Region .....	12
6.	Regional R/R MEP Architecture .....	12
6.1.	Introduction of R/R MEP Solution.....	12
6.2.	Candidate Architecture using API GW or Forward/Reverse Proxy.....	13
6.3.	Candidate Architecture using Message Broker (AMQP).....	15
6.4.	Approach on Topology in Support of R/R MEP in Asia/Pacific Region .....	16
7.	Routing Mechanism .....	16
7.1.	Routing Mechanisms.....	16
7.1.1.	Path Based Routing.....	16
7.1.2.	Contents Based Routing.....	17
7.2.	Recommendation on Routing Mechanism of R/R MEP in Asia/Pacific Region.....	19
8.	Any Other Considerations.....	19
9.	Annexes.....	20

9.1.	Annex 1 – Synchronous and Asynchronous R/R Data Flow Diagram.....	20
9.2.	Annex 2 – Applicability of Synchronous and Asynchronous R/R MEP to FF-ICE Service .....	21
9.3.	Annex 3 – FF-ICE Service Data Flow Diagrams of Synchronous and Asynchronous R/R MEP	22

# 1. Introduction

## 1.1. Background

### 1.1.1. SWIM Implementation Pioneer Ad-hoc Group (SIPG)

The establishment of SIPG was decided at the SWIM TF/7 in 2023, and its Terms of Reference (TOR) was endorsed by the SWIM TF/? under the “”. Following SIPG’s TOR, the initial objective of the SIPG was to implement a seed/prototype version of the Asia/Pacific SWIM within 2024 as a means of kickstarting SWIM adoption in the region. Based on the initial objectives SIPG, SIPG built prototype version of Asia/Pacific SWIM and supported SWIM Demonstration over CRV and surveillance data sharing in the SWIM trial in Hong Kong, China, from 28 to 29 May 2024

After the supported SWIM Demonstration over CRV and surveillance data sharing in the SWIM trial, there were still needs for an expert group that can provide technical work for SWIM implementation in the Asia/Pacific region, and the SIPG continues its work in response to the need. In line with this, the SIPG defined sub-tasks to further materialize the implementation of SWIM in the Asia/Pacific region, and the sub-tasks, which are currently identified and in progress by the end of Dec 2026, as of Sep. 2025, are as below:

- Task 1: Requirements and Functionalities of the Edge EMS and Gateway EMS
- Task 2: New proposed hierarchical architecture review
- **Task 3: Guidance for the Sync Req/Rep and Async Req/Rep Message Exchange Pattern**
- Task 4:
- Task 5 : SWIM Technical Infrastructure Integration
- Task 6: SWIM Security Requirements and Implementation
- Task 7: SWIM Registry Requirements and Implementation
- Task 8:
- Task 9: APAC SWIM Integration Testing
- Task 10: Performance Testing SWIM TI
- Task 11: Regional SWIM TI Operationalization Guidance Material

### 1.1.2. Limitation of the Previous SWIM Efforts in the Asia/Pacific Region

There have been various efforts for the implementation of SWIM in the Asia/Pacific region. These efforts are not only about the establishment of regional implementation guidance or standardization, but also implementation of regional SWIM prototype, and demonstrations. However, regarding the demonstration and technical efforts for message delivery, these efforts were mostly depended on an Enterprise Messaging System (EMS) using Publish and Subscribe (Pub/Sub) Message Exchange Pattern (MEP), as mentioned in “APPROACH TO GLOBAL API GATEWAY FOR WEB SERVICE (SWIM TF/10 – WP/18)”.

A MEP refers to the fundamental interaction mechanism that defines how messages are exchanged between heterogeneous systems. There are a few mechanisms to enable MEP such as Pub/Sub, Request and Reply (R/R), and Fire and Forget. And, ICAO SWIM Implementation document (Doc. 10203) identified this mechanism for MEP in the SWIM. However, given the current emphasis on the regional SWIM prototype architecture using an EMS which the SIPG is developing in the APAC region, the primary issue is to discuss how the Request/Reply MEP should be implemented.

## 1.2. Guidance Materials

Guidance materials (i.e. this document) is one of the deliverables of Task 3 under SIPG. Republic of Korea, Australia, China, Hong Kong China, India, Japan, Fiji, Singapore, Thailand, Malaysia, USA, New Zealand. CANSO have volunteered and contributed to producing this document.

## 1.3. Purpose of the Document

This document provides guidance for R/R MEP in the Asia/Pacific region, and it covers business and technical aspect of R/R MEP including FF-ICE/R1 based a data flow and use-case diagram, with the purpose of ensuring continuous and coherent implementation of the R/R MEP to SWIM platform in harmonized and interoperable within the region.

## 2. Operational Concept

This chapter introduces the operational concept of the R/R MEP. It describes the definition of the R/R MEP, identifies the core components of the R/R MEP, including participants, synchronization mechanisms, and supporting elements.

### 2.1. Definition of R/R MEP

The R/R MEP is a communication model where a requester sends a request message to a replier, which then processes the message and returns a reply.

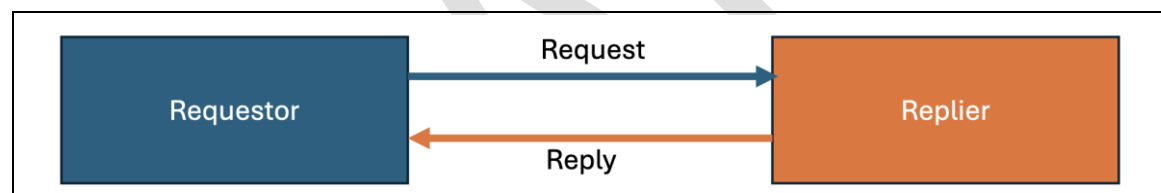

Figure X. Diagram

### 2.2. Components of R/R MEP

The components of R/R MEP could be distinguished as follows:

#### **Core Participants**

- **Requester:** The requester asks for something via a request; it could be simply considered as Create, Read, Update, Delete (CRUD) operation
- **Replier:** The replier processes the request and return a message in reply

#### **Synchronization Mechanisms**

- **Synchronous:** The requester waits for the response before continuing its operation
- **Asynchronous:** The requester's control flow is released after the request is sent, and the response is handled later, perhaps via a callback or another mechanism.

#### **Supporting Elements**

- **Payload:** it defines the actual contents of the message being exchanged. This could be Extensible Markup Language (XML), JavaScript Object Notation (JSON)
- **Transportation and Protocol Binding:** it defines how the R/R is implemented. This could be Hyper Text Transfer Protocol/Representational State Transfer (HTTP/REST), Simple

Object Access Protocol (SOAP), Advanced Messaging Queue Protocol (AMQP), Message Queuing Telemetry Transport (MQTT)

- **Error and Exception Handling:** it provides mechanism to manage any other errors or exceptions such as failures, timeouts, and invalid requests
- **Security and Policy Enforcement:** it provides authentication, authorization, encryption, compression, logging mechanism

### 3. R/R MEP in SWIM

This chapter provides the conceptual framework of R/R MEP within the SWIM environment. It identifies the role of R/R MEP at the global level, and in the Asia/Pacific region, explains how the R/R MEP operates under different synchronization mechanisms, Furthermore, it provides comparison between synchronous and asynchronous R/R MEP, points out possible confusion part and clarifies them.

#### 3.1.R/R MEP in the Global Level

ICAO SWIM Implementation Document (Doc. 10203) defined MEP including synchronous and asynchronous R/R as follows:

##### 5.3.2.4.2 *Message exchange patterns*

5.3.2.4.2.1 Several types of message exchange patterns (MEPs) are expected to be supported within a SWIM environment, including synchronous request/reply, asynchronous request/reply, one-way ("fire-and-forget") and publish/subscribe. The MEP used in any given exchange is directed by the information service provider to meet information service objectives. These MEPs include:

- a) **Synchronous request/reply:** The consumer initiates a request to an information service; the service processes the request and generates a reply to the consumer. The consumer waits for the information service to provide a response. During this waiting period, the consumer cannot send or receive any other requests or responses. This pattern is specifically applicable to information services that can quickly execute and respond to consumer requests;
- b) **Asynchronous request/reply:** The consumer initiates a request to an information service; the service processes the request and generates a reply to the consumer. However, the consumer is not restricted from performing other operations while waiting for the information service's response. This MEP requires that the consumer be able to receive messages at any time and correlate them with prior requests;
- c) **One-way ("fire-and-forget"):** The consumer initiates a message to an information service without expecting any response from the information service. This MEP is particularly useful at the lower application layer, where immediate message responses are not required;
- d) **Publish/subscribe (P/S):** The consumer initiates a subscription request to an information service. The subscription may be capable of providing details (such as through a filtering parameter) on the information being subscribed to:
  - 1) in the case of a P/S with a push mechanism, the information service sends necessary updates (publish) to the consumer, in accordance with the subscription. This MEP requires that the consumer can receive messages at any time. However, the consumer is not restricted from completing other operations while waiting for the information service to respond; and
  - 2) in the case of a P/S with a pull mechanism, the information service would keep necessary updates available to the consumer, in accordance with the subscription. This MEP requires that the consumer send requests to the information service to receive the updates.

Figure X. Diagram

## 3.2.R/R MEP in the Asia/Pacific Region

ICAO APAC SWIM Implementation Guidance Document (IGD, Working Draft) defines MEP including R/R as follows:

### 3.3.2 Standards for Resource-oriented Interface

#### 3.3.2.1 RESTful API

The following table makes reference to RESTful API related standards and specifications required for supporting the service or infrastructure bindings of SWIM TI.

### 3.3.3 Standards for Method-oriented Interface

#### 3.3.3.1 OGC WCS

The Open Geospatial Consortium (OGC) has developed a number of Web Common Service (WCS) standards that define services for accessing and manipulating geospatial data in a web environment, such as aeronautical information and meteorologic information. The following table makes reference to some of the key WCS standards and specifications required for supporting the service or infrastructure bindings of SWIM TI.

#### 3.3.3.2 SOAP

As most users have not applied SOAP to current web applications, this standard is not recommended for the development of SWIM services. The following table makes reference to SOAP related standards and specifications required for supporting the service bindings of SOAP applications.

### 4.1 Functional Capabilities

The SWIM TI functional capabilities described in this section are common features widely supported by mainstream Commercial Off The Shelf (COTS) systems and services. Implementing a SWIM TI that supports all these capabilities is recommended. The SWIM TI functional capabilities can be grouped into three categories as follows:

Table 8. SWIM TI Functional Capabilities

Capability	Description	Related Technology
Messaging	This capability employs technologies that enable information exchange using various access methods (e.g., publish/subscribe, request/reply).	- Message brokers: such as Apache Kafka, RabbitMQ, ActiveMQ.

Figure X. Diagram

*Note: This section is intended for the business experts group of the ICAO APAC region to explain why this document does not select SOAP as one of the candidate technologies to be explored, despite the fact that Eurocontrol's SWIM implementation uses SOAP for R/R MEP.*

## 4. Mechanism

This chapter outlines the mechanism of the R/R MEP. It explains the difference between synchronous and asynchronous interactions, compares their characteristics, and highlights common points of confusion. It also clarifies how R/R MEP should be understood from a business perspective to support consistent implementation in the Asia/Pacific SWIM environment.

### 4.1.Synchronous R/R MEP

In ICAO SWIM Implementation Document, synchronous R/R MEP is defined as – *The consumer initiates a request to an information service; the service processes the request and generate a reply to the consumer. The consumer waits for the information service to provide a response. During this waiting period, the consumer cannot send or receive any other requests or responses. This pattern is specifically applicable to information services that can quickly execute and respond to consumer request*

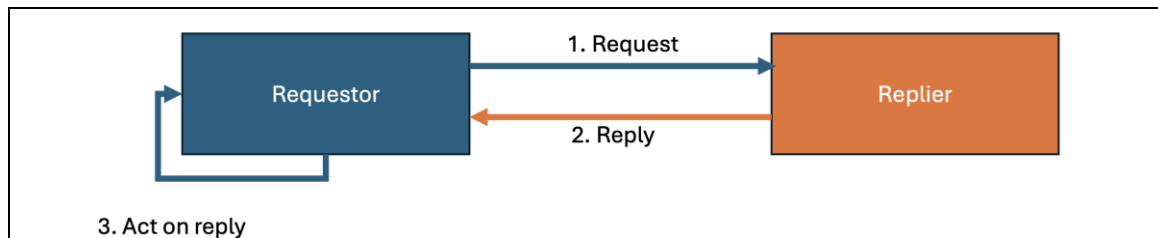

Figure X. Diagram

### 4.2.Asynchronous R/R MEP

In ICAO SWIM Implementation Document, asynchronous R/R MEP is defined as – *The consumer initiates a request to an information service; the service processes the request and generates a reply to the consumer. However, the consumer is not restricted from performing other operations while waiting for the information service’s response. This MEP requires that the consumer be able to receive messages at any time and correlate them with prior requests*

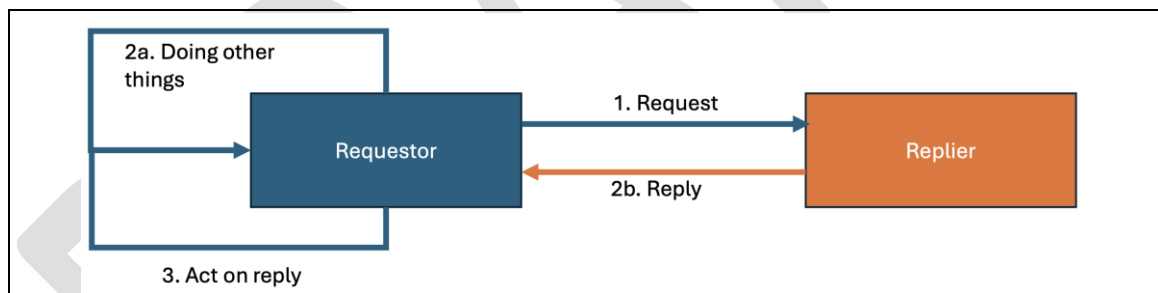

Figure X. Diagram

### 4.3. Comparison of Synchronous and Asynchronous R/R MEP

Comparison of synchronous and asynchronous R/R MEP is as follows:

Index	Synchronous	Asynchronous
Time Coupling	Both requester and replier are available at the same time.	Requester sends a request and continues its process; replier can send the response later when available.
Space Coupling	Requester needs to know the exact service endpoint (protocol, address, API).	Requester sends to a known endpoint, but response may arrive via callback, polling, or correlation ID; looser coupling in response handling.
Reliability Handling	Retries and error handling happen at requestor side.	Retries and correlation of delayed responses must be managed at the

		requester side (e.g., matching reply with original request).
Use Cases	<ul style="list-style-type: none"> <li>• Low latency expected</li> <li>• Both parties are available</li> <li>• Immediate response interaction</li> </ul>	<ul style="list-style-type: none"> <li>• Replier may not be immediate</li> <li>• Deferred or background processing acceptable</li> </ul>
Typical Scenarios	<ul style="list-style-type: none"> <li>• User Authentication</li> <li>• User Interface Interactions</li> <li>• Database Read and Immediate Write</li> </ul>	<ul style="list-style-type: none"> <li>• Order processing with delayed confirmation</li> <li>• Flight plan filing with later validation</li> <li>• Weather data request with queued response</li> <li>• Batch data processing</li> </ul>

Table X. Table

#### 4.4. Confusion between Synchronous and Asynchronous R/R MEP

In real-world implementations, confusion often arises when distinguishing between synchronous and asynchronous Request/Reply (R/R) patterns, especially in cases where a service returns an immediate acknowledgment (e.g., Status code without payload) but the actual business result (e.g., Payload) is provided later.

This confusion was raised at the SWIM TF/10 – Approach to Global API Gateway for SWIM Web Services (WP/01) and SIPG WS/2 - *Request-Reply Message Exchange Pattern (SP/09)*.

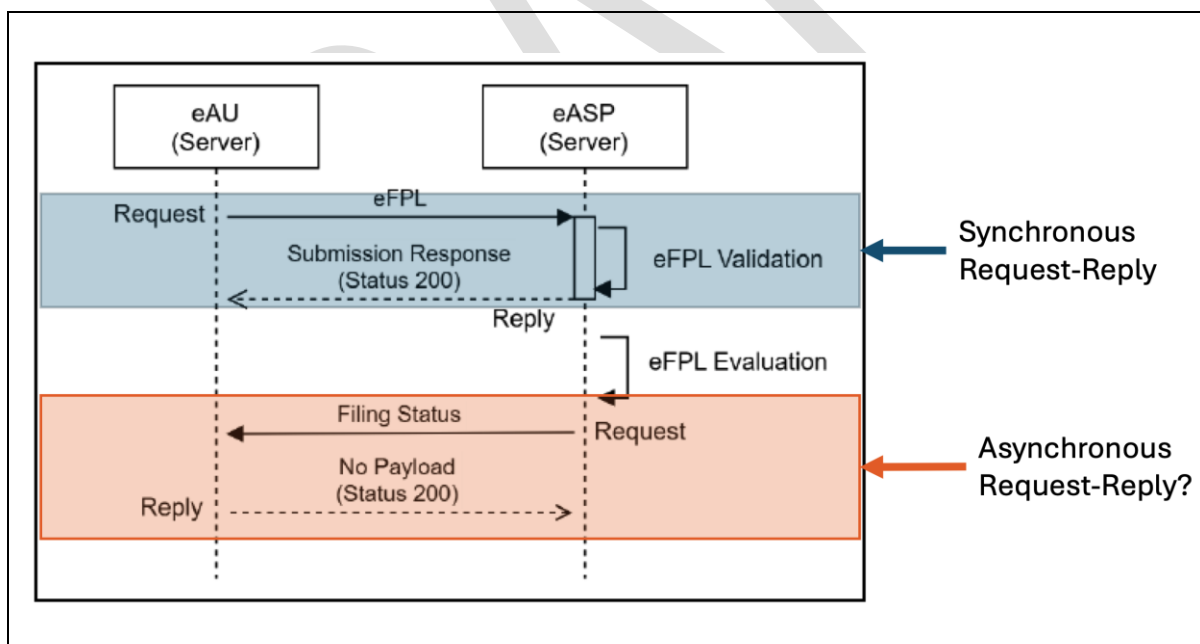

Diagram X. Diagram

From a **technical perspective**, when a requester sends a message and immediately receives a system-level response (e.g., status code with no payload), this exchange may be classified as **synchronous**. The requester technically obtains a reply within the same transaction, even if that reply does not contain the final outcome of the request.

From a **business perspective**, however, the true result of the request (e.g., validation outcome, processing status, or evaluation result) is delivered at a later stage. The requester must therefore

rely on additional asynchronous mechanisms—such as callbacks, notifications, or correlation with a subsequent message—to complete the intended business process. In such cases, the service behavior is effectively **asynchronous**, because the requester cannot proceed with its operational workflow until the deferred reply is received.

This duality highlights that:

- At the **technical-level**, an immediate acknowledgment can be interpreted as synchronous.
- At the **business-level**, the process may still be asynchronous if the final response is decoupled from the initial request.

To make it clear and reduce the nuisance triggered by the confusion mentioned above, when designing or documenting R/R MEP in SWIM, it is important to clearly differentiate between **technical-level of synchronization** and **business-level of synchronization**, to avoid misinterpretation and ensure consistent implementation across different systems and stakeholders.

#### 4.5. Clarification of Synchronous and Asynchronous R/R MEP

To resolve the confusion described in the previous section, it is necessary to establish a clear basis for distinguishing between synchronous and asynchronous R/R MEP.

From a **technical perspective**, any immediate acknowledgment could be appeared as a synchronous, since the requester receives a response without delay. However, this does not always reflect the completion of the underlying business process.

Therefore, for the purpose of SWIM implementation in the Asia/Pacific region, the classification of R/R MEP shall be **defined from the business perspective**:

- If the requester can complete its intended **business operation** immediately upon receiving the reply, the interaction is considered **Synchronous R/R**.
- If the requester must wait for an additional message or deferred processing result in order to complete its **business operation**, the interaction is considered **Asynchronous R/R**.

Classification	Case/Description	Technology
Synchronous Response	<b>ACK + Final Result Payload</b> <i>Returns an acknowledgment together with the final result (payload). No further response is expected.)</i>	<b>HTTP-based Synchronous R/R</b> <i>HTTP 200 OK + payload result</i>
Asynchronous Response	<b>ACK + Partial / Meta Payload</b> <i>Returns an acknowledgment along with some meta information or partial result (payload). The result will be delivered later through the same or a different channel.</i>	- <b>HTTP-based Asynchronous R/R</b> <i>HTTP 200 Accepted → HTTP later callback</i> - <b>AMQP-based Asynchronous R/R</b> <i>AMQP ACK (Accepted) → asynchronous reply via reply-to queue with matching correlation-id</i>
	<b>ACK Only</b> Simply acknowledges that the request has been accepted The actual result will be sent asynchronously via a designated reply mechanism (e.g., callback endpoint, reply queue, topic, or event).	- <b>Hybrid Asynchronous R/R</b> <i>HTTP 202 Accepted → final result via MQ (reply queue)</i>

By adopting this **business-oriented definition**, system designers and stakeholders can avoid misinterpretation caused by protocol-level acknowledgments and instead align the classification of R/R MEP with operational reality. This ensures that the design of SWIM services, including error handling, correlation mechanisms, and user expectations, is consistent with the actual business workflows they are intended to support.

Table X provides examples that bridge the business and technical perspectives of **asynchronous** R/R MEP. It highlights that a transaction may appear synchronous at the protocol level, yet still behave asynchronously from a business process standpoint.

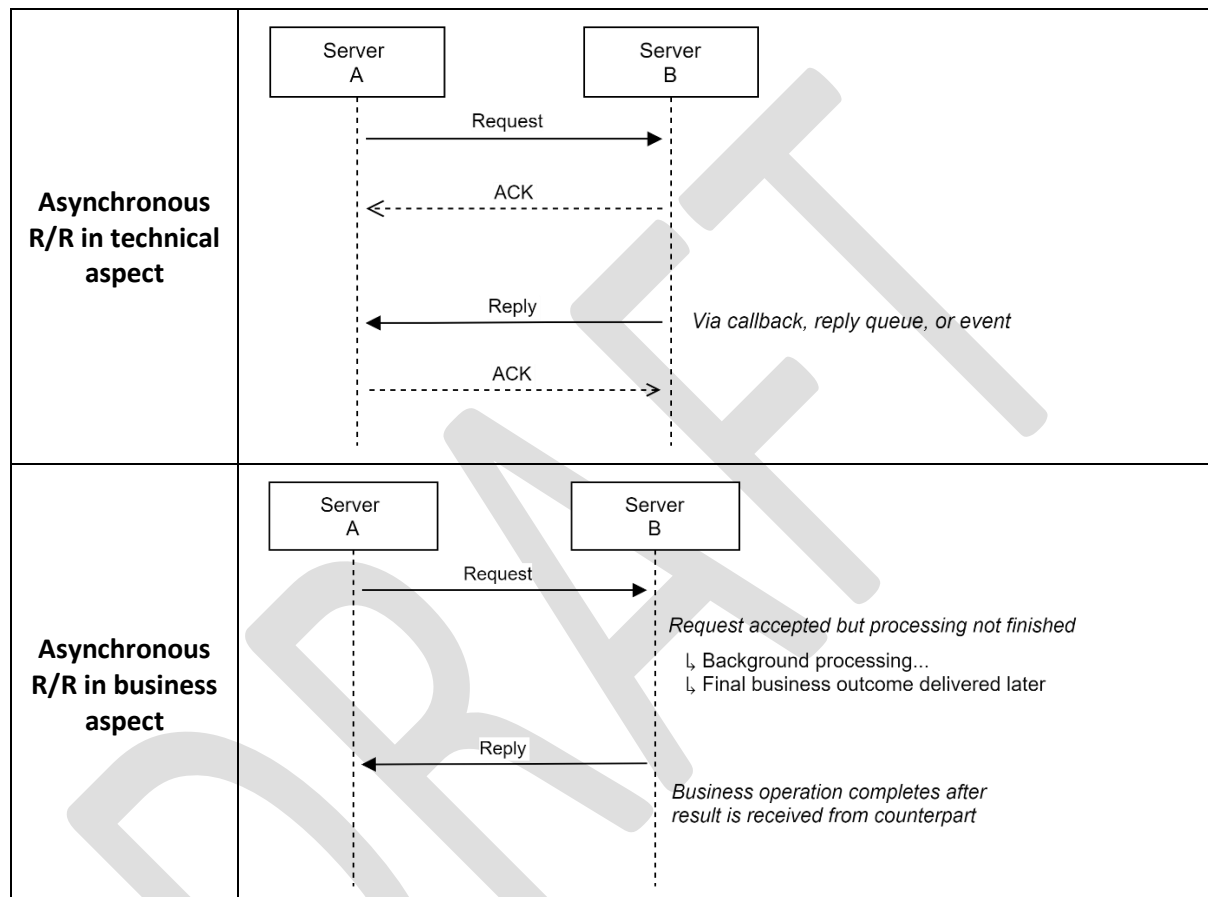

Table X. Table

## 5. Implementation

This chapter explains practical methods that could be adopted to implement the R/R MEP in the SWIM environment. It describes technical options for both synchronous and asynchronous interactions, evaluates their suitability for Asia/Pacific SWIM, and provides regional approach.

### 5.1. Implementation of Synchronous R/R MEP

Synchronous R/R interactions can be effectively implemented using lightweight, stateless web service technologies as follows:

- a. REST API (HTTP/HTTPS)
  - A requester sends an HTTP request (e.g., GET, POST, or DELETE) and waits for an immediate reply from counterpart
  - The response includes both status code (e.g., HTTP status code 200 - OK, HTTP status code 400 - Bad Request) and, a payload (e.g., JSON, XML)
  - RESTfAPI represents the de-facto for synchronous R/R interactions in the ICT industry
  - This approach aligns with the APAC SWIM regional strategy, as REST is widely supported, interoperable, and well-suited for cross-domain information exchange
- b. SOAP (HTTP/HTTPS)
  - SOAP provides a rigid XML-based messaging protocol and was historically used for enterprise-level synchronous R/R.
  - However, as stated in previous chapters, although SOAP also could be enabled using HTTP/HTTPS, unlike REST, SOAP is not recommended to use due to its complexity, high overhead, and limited scalability due to its constraints as follows:
    - Only XML is supported, other data format like JSON is not supported
    - Requires WSDL (Web Services Description Language) for service definitions, which adds complexity at the initial setting;
    - SOAP's components such as envelop have an overhead, but a bandwidth of CRV is one of the major issues in the Asia/Pacific region;
- c. Other Protocol Bindings
  - While synchronous R/R can also be implemented over other protocols (e.g., gRPC, GraphQL, even AMQP), these remain optional and are not stated at the IGD at the regional level.

## 5.2.Implementation of Asynchronous R/R MEP

Asynchronous R/R interaction is not directly related to whether processing can be completed instantly or not, or whether replies must be deferred. Implementation options could be as follows:

- a. REST API (HTTP/HTTPS) with Asynchronous Callback
  - A requester sends an HTTP request and receives an immediate acknowledgment (status code).
  - The actual business result is delivered later via an HTTP callback endpoint provided by the requester. This solution (a) is the callback mechanism that is limited to HTTP/HTTPS-based endpoints;
  - This requires correlation mechanisms to match replies with original requests.

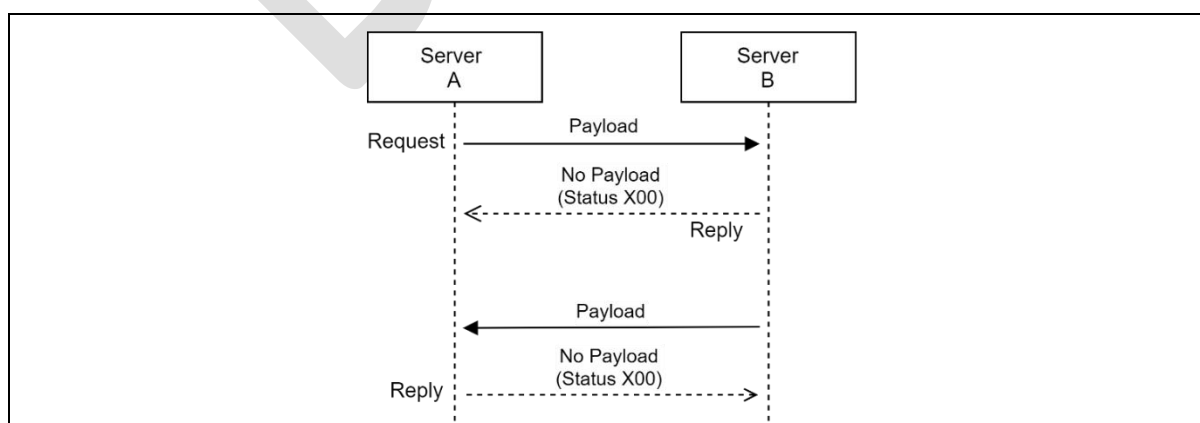

Diagram X. Diagram

b. REST API (HTTP/HTTPS) with Polling

- The requester periodically polls the service to check the status of its request.
- While simple, polling may cause inefficiencies in bandwidth usage and should be applied only for services with low response frequency.

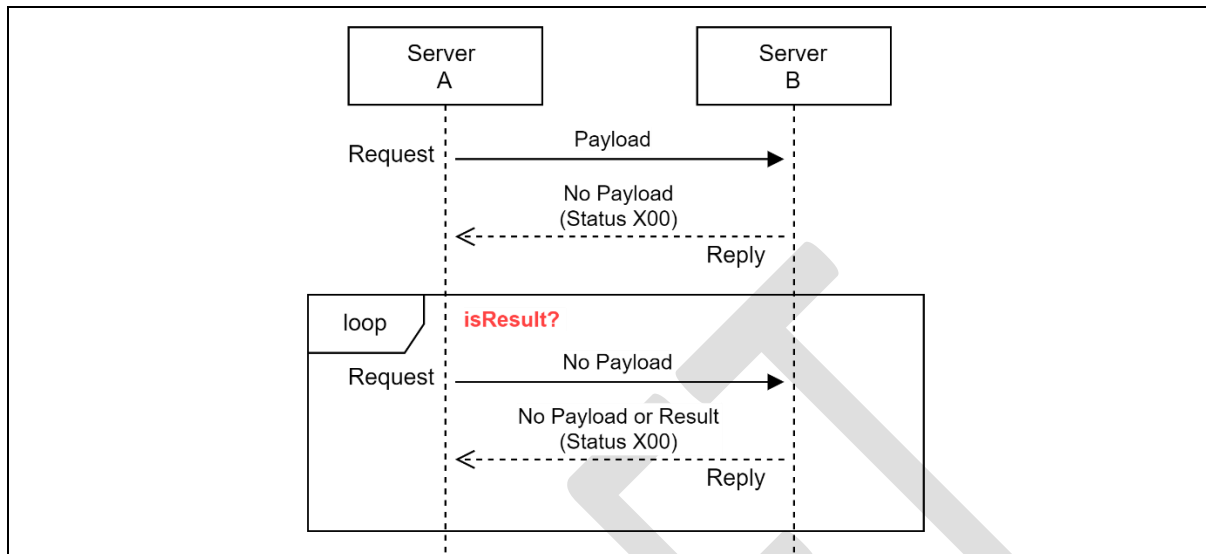

Diagram X. Diagram

c. Message Queue

- AMQP or MQTT can be used to implement asynchronous R/R interactions in distributed environments.
- AMQP properties (e.g., correlation-id, reply-to) must be configured to send request a query, and the message broker uses or creates shared or exclusive queue to handle the R/R MEP.
- Counterpart processes a request query, generates a corresponding reply using the same correlation-id, and returns it to the queue or topic specified in the reply-to property.

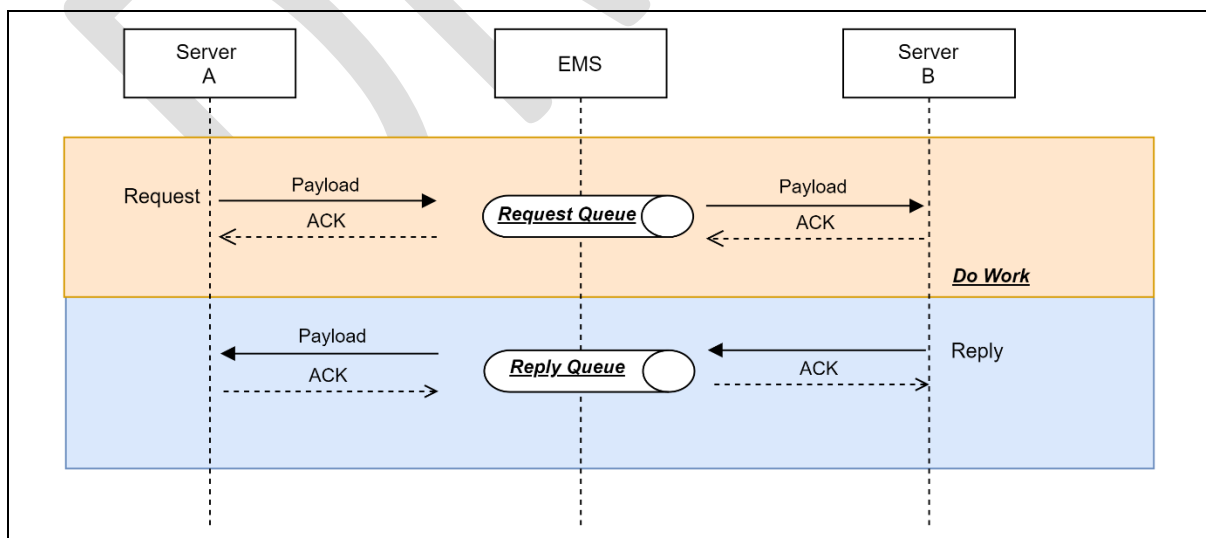

Diagram X. Diagram

## d. REST API–Message Queue Bridge

- Most modern message brokers provide a REST API interface. A gateway service, either built into the broker or deployed as a standalone component, performs protocol conversion between AMQP and HTTP.
- This provides a REST API interface externally while using asynchronous message queue–based message delivery internally. Internal message delivery is the same as described in the (c)

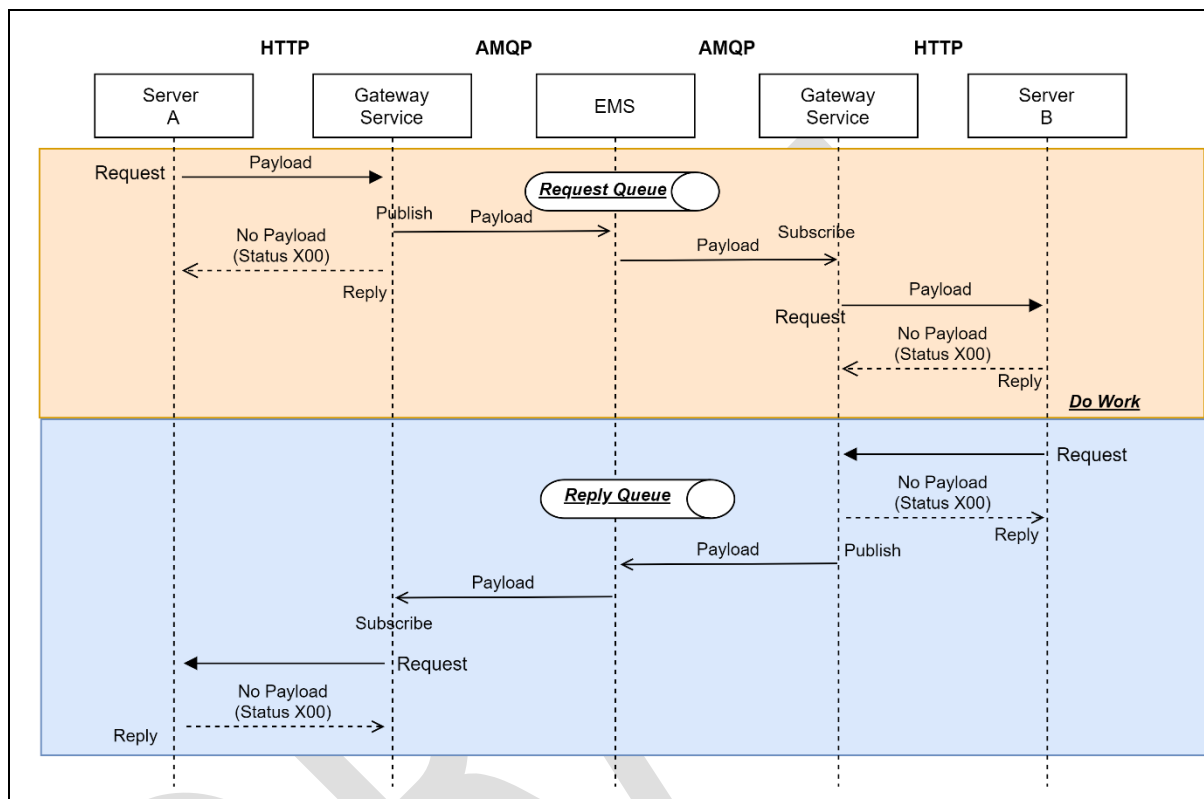

Diagram X. Diagram

## a. Synchronous REST with Asynchronous Event Delivery using Message Queue

- This pattern is asynchronous R/R MEP implementation of Network Manager (NM), Eurocontrol. The pattern is composed of two parts:
  - Synchronous part: The server sends HTTP request, and the counterpart returns reply. If the status of the information reply is OK, the server extracts the information on how to consume the asynchronous reply message, the pattern continues with the asynchronous part
  - Asynchronous part: The server connects to the broker and consumes the asynchronous reply message
- This pattern allows integration of REST API with asynchronous processing workflows using message queue

Click link to see more about asynchronous R/R MEP of NM, Eurocontrol - [NM Release Notes](#)

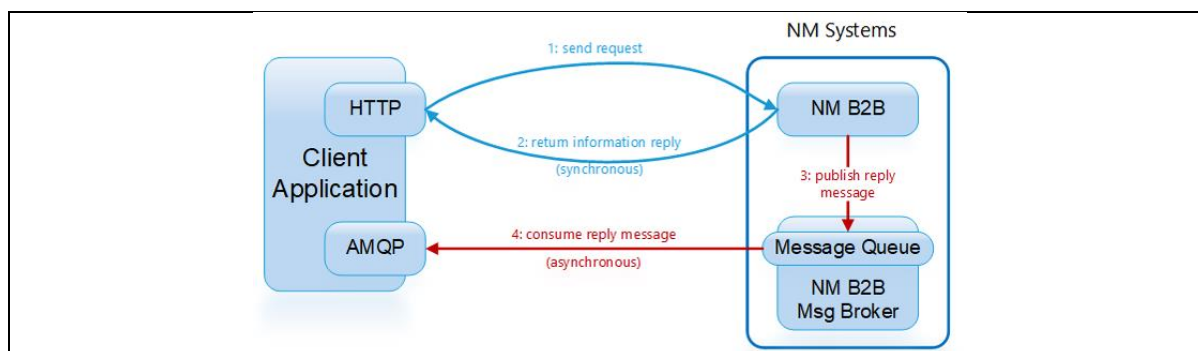

Diagram X. Eurocontrol Network Manager 26.0 Release Note ed.5

### 5.3. Approach on Implementation of R/R MEP in Asia/Pacific Region

For the Asia/Pacific SWIM environment, the following implementation approaches could be explored and adopted to ensure harmonization and interoperability among diverse stakeholders:

#### **Synchronous R/R MEP – REST API via HTTP/HTTPS**

For synchronous Request/Reply MEP, **REST API via HTTP/HTTPS** could be considered

Appendix X shows the sequence diagram of synchronous R/R MEP using REST API via HTTP/HTTPS

#### **Asynchronous R/R MEP – REST API via HTTP/HTTPS with Asynchronous Callback**

For asynchronous interactions, **1) REST API with asynchronous callback, 2) Message Queue 3) Synchronous REST API with Asynchronous Event Delivery using Message Queue** could be considered.

Appendix X shows the sequence diagram of 1) REST API via HTTP/HTTPS with asynchronous callback, 2) Message Queue-based Asynchronous R/R via AMQP, MQTT

In some cases, to support its business operation, information exchange may involve a combination of **Synchronous R/R MEP, Asynchronous R/R MEP, and P/S MEP** patterns. However, this document doesn't describe it in detail.

## 6. Regional R/R MEP Architecture

This chapter outlines the topology of the R/R MEP. Specifically, it explains which R/R MEP solutions could be considered, and what architecture could be used to deploy those products or solutions to enable both synchronous and asynchronous R/R MEP within the region.

### 6.1. Introduction of R/R MEP Solution

- a. Forward/Reverse Proxy
  - A forward proxy acts on behalf of an internal resource (e.g., client, server, or system), managing outbound requests to an external resource (e.g., client, server, or system) to provide capabilities such as access control, caching, and monitoring.
  - A reverse proxy acts on behalf of an external resource (e.g., client, server, or system), managing inbound requests to internal resource (e.g., client, server, or system) to security, load balancing, and routing, while hiding internal system details.
  - Comparison of forward and reverse proxy is as follows:

Aspect	Forward Proxy	Reverse Proxy
Diagram		
Traffic Direction	Handles outbound requests from internal resource to external resource	Handles inbound requests from external resource to internal resource
Visibility	Hides the internal resource's identity from external resource	Hides the internal resource's identity to external resource

Table X. Table

- Forward and reverse proxy supports OSI 3<sup>rd</sup>, 4<sup>th</sup>, and 7<sup>th</sup> layer protocols such as HTTP, Web-socket, TCP, UDP, IP. Main focus of forward and reverse proxy is message routing.
- b. API Gateway
  - An API Gateway (GW) is built on top of a reverse proxy, primarily supporting HTTP and providing advanced API management capabilities. The main difference between an API GW and a reverse proxy lies in how policies are applied and managed from an API management perspective.

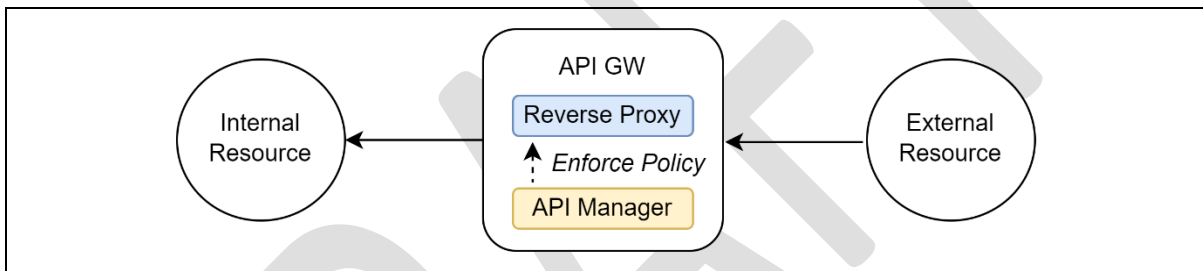

Diagram X. Diagram

## 6.2.Candidate Architecture using API GW or Forward/Reverse Proxy

This section describes candidate architectures that could be applied for synchronous and asynchronous R/R MEP using REST API (HTTP)

- a. Full Mesh Architecture
  - Same as Decentralized Approach of EMS interconnectivity architecture presented in WP05,SWIM/TF8. A service interacts with its own Edge API GW, and the Edge API GW directly forwards the request to another Edge API GW.

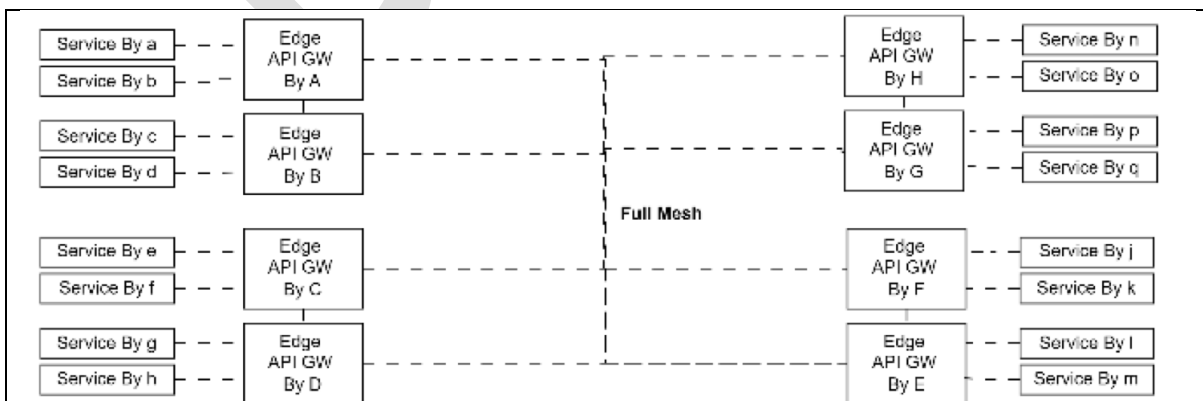

Diagram X. Diagram

- b. Centralized Architecture

- Same as Centralized Approach of EMS interconnectivity architecture presented in WP05, SWIM/TF8 API GW acts as a single-entry point for all services between member states

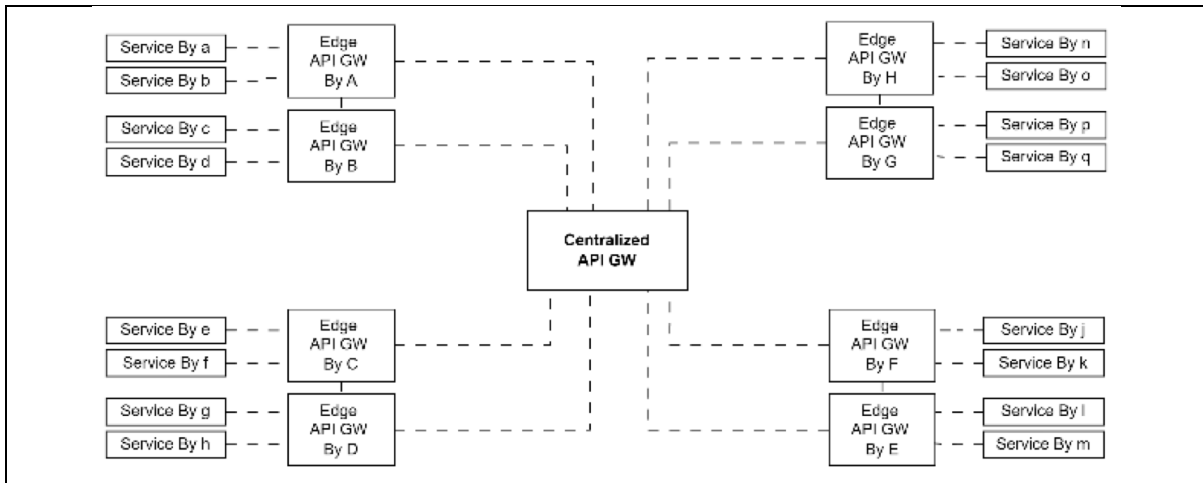

Diagram X. Diagram

c. Hierarchical Architecture

- Same as Hierarchy Approach of EMS interconnectivity architecture presented in WP05, SWIM/TF8. Edge API GW interacts with Regional API GW, which handle routing within sub-community or forward requests to other sub-community.

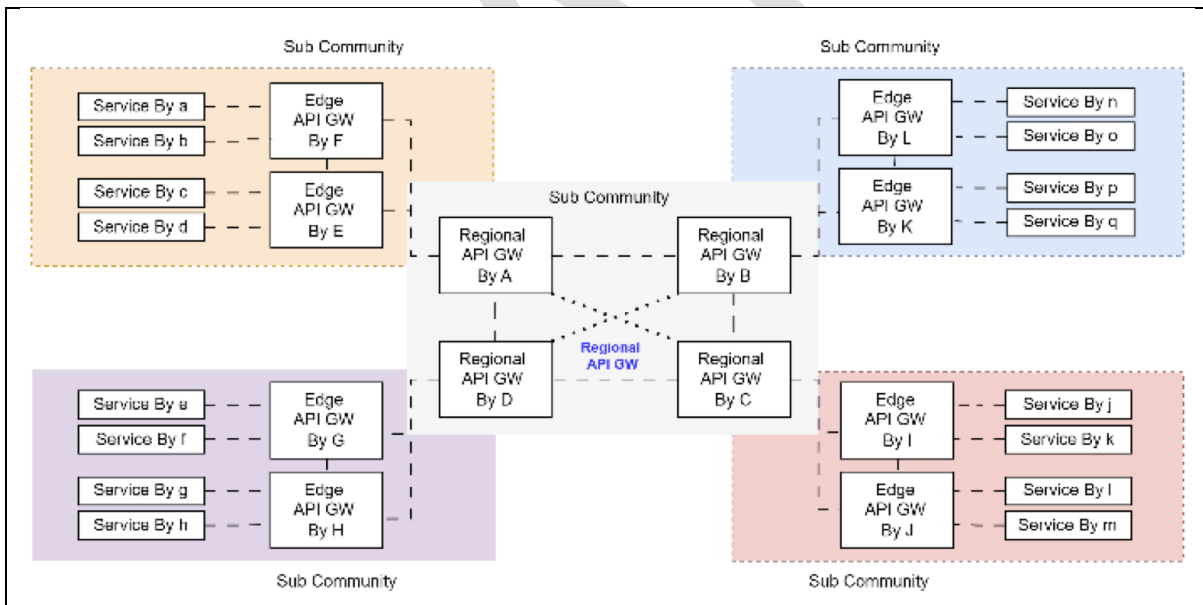

Diagram X. Diagram

d. Two-layered Hierarchical Architecture

- Same as Modified Hierarchy Approach of EMS interconnectivity architecture. presented in SP07 SIPG/WS8. Two-layer hierarchical API GW architecture with a clustered regional layer

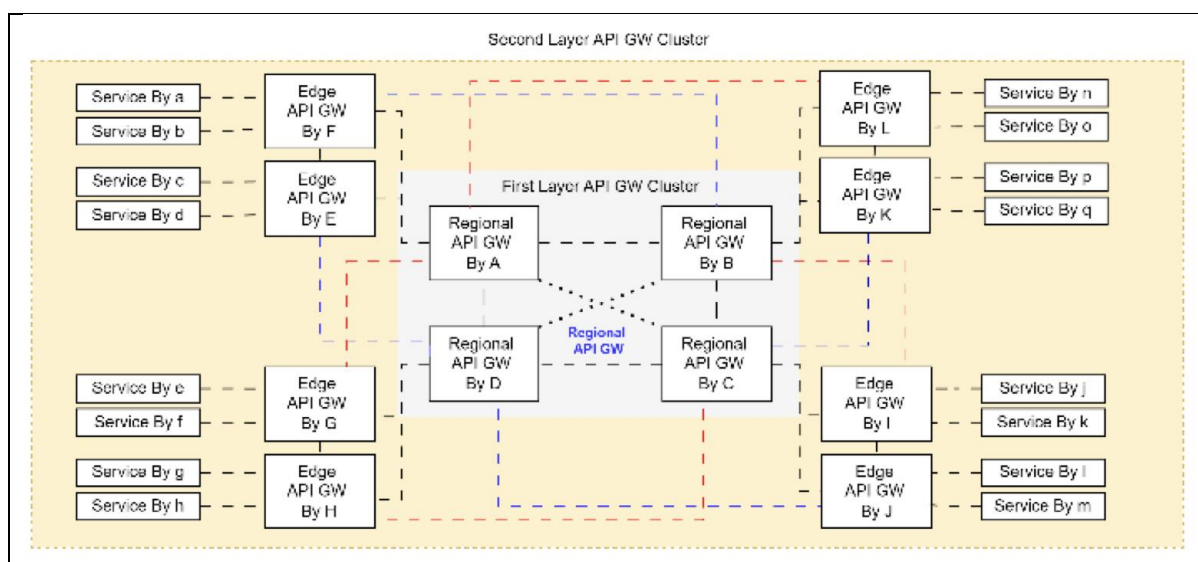

Diagram X. Diagram

Comparison of candidate architectures is as follows:

Architecture	Pros	Cons
Full Mesh	<ul style="list-style-type: none"> <li>- Low dependency between API GWs</li> <li>- Easy to implement</li> <li>- High Sovereign</li> </ul>	<ul style="list-style-type: none"> <li>- All API GW should be ready for cross-border data exchange (e.g., bridge to SOAP for European region)</li> <li>- API GW should be able to get connected with all API GW interested</li> <li>- All API GW should be updated when there is a policy/configuration change</li> </ul>
Centralized	<ul style="list-style-type: none"> <li>- Simple communication</li> <li>- Easy to configure policy</li> </ul>	<ul style="list-style-type: none"> <li>- Low Sovereign</li> <li>- Centralized API GW is SPOF</li> </ul>
Hierarchical	<ul style="list-style-type: none"> <li>- Efficient for cross border data exchange</li> <li>- A configuration change could be affected to only regional API GWs</li> </ul>	<ul style="list-style-type: none"> <li>- Regional API GW is SPOF</li> </ul>
Two Layered Hierarchical	<ul style="list-style-type: none"> <li>- Higher Fault tolerance</li> <li>- Better HA and scalability</li> </ul>	<ul style="list-style-type: none"> <li>- High cost for maintenance</li> <li>- Management Complexity</li> </ul>

### 6.3.Candidate Architecture using Message Broker (AMQP)

This section describes the candidate architecture that could be applicable to synchronous and asynchronous R/R MEP using Message Broker (AMQP).

As modified hierarchy approach of EMS interconnectivity architecture, presented in SP07 SIPG/WS8 is information backbone for P/S MEP in the region. To enable synchronous and asynchronous R/R MEP using Message Broker (AMQP), same architecture is better to be used.

As of Oct. 25, Implementation of two layered hierarchical architecture (i.e., APAC SWIM P/S MEP architecture) is in progress under SIPG Task 1 and Task2.

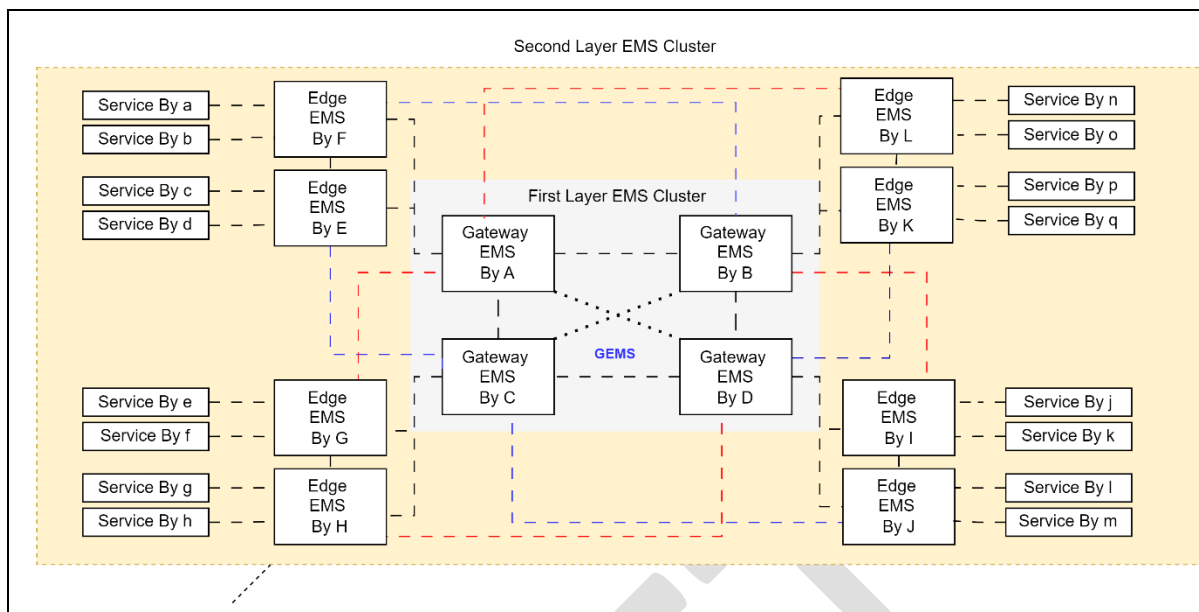

Diagram X. Diagram

## 6.4. Approach on Topology in Support of R/R MEP in Asia/Pacific Region

For the Asia/Pacific SWIM environment, the following solution and architecture could be explored in support of R/R MEP in the region before adoption.

For synchronous Request/Reply MEP, **1) API GW + Full Mesh Architecture** or **2) API GW + Two Layered Hierarchical Architecture** could be considered

For asynchronous Request/Reply MEP, **1) API GW + Full Mesh Architecture** or **2) API GW + Two Layered Hierarchical Architecture**, and **3) Message Broker + Two Layered Hierarchical Architecture (i.e., APAC SWIM P/S MEP Architecture (co-use))** could be considered

## 7. Routing Mechanism

This chapter introduces routing mechanisms for R/R MEP. In R/R interactions, a message sent by a requester must be delivered to the correct replier through the API GW or message broker. Therefore, routing mechanism plays a critical role in ensuring that requests are directed to the right service and that responses are returned correctly. There are many different routing mechanisms for R/R MEP such as Path-based Routing, Content-based Routing, Header-based Routing, Policy-based Routing, and so on, but this chapter only describes Path-based Routing, and Contents-based Routing. They are mentioned as they represent the most fundamental and widely applicable approaches. These two mechanisms provide a clear contrast between simplicity and flexibility: Path-based routing offers transparency and ease of configuration, while Content-based routing enables dynamic and context-driven service delivery. This could be mapped with message routing for Topic and Queue in Pub/Sub MEP.

### 7.1. Routing Mechanisms

#### 7.1.1. Path Based Routing

Path-based routing is the simplest and most commonly used routing mechanism. In this approach, the Uniform Resource Identifier (URI) path or topic within the HTTP or AMQP request determines the destination of the message.

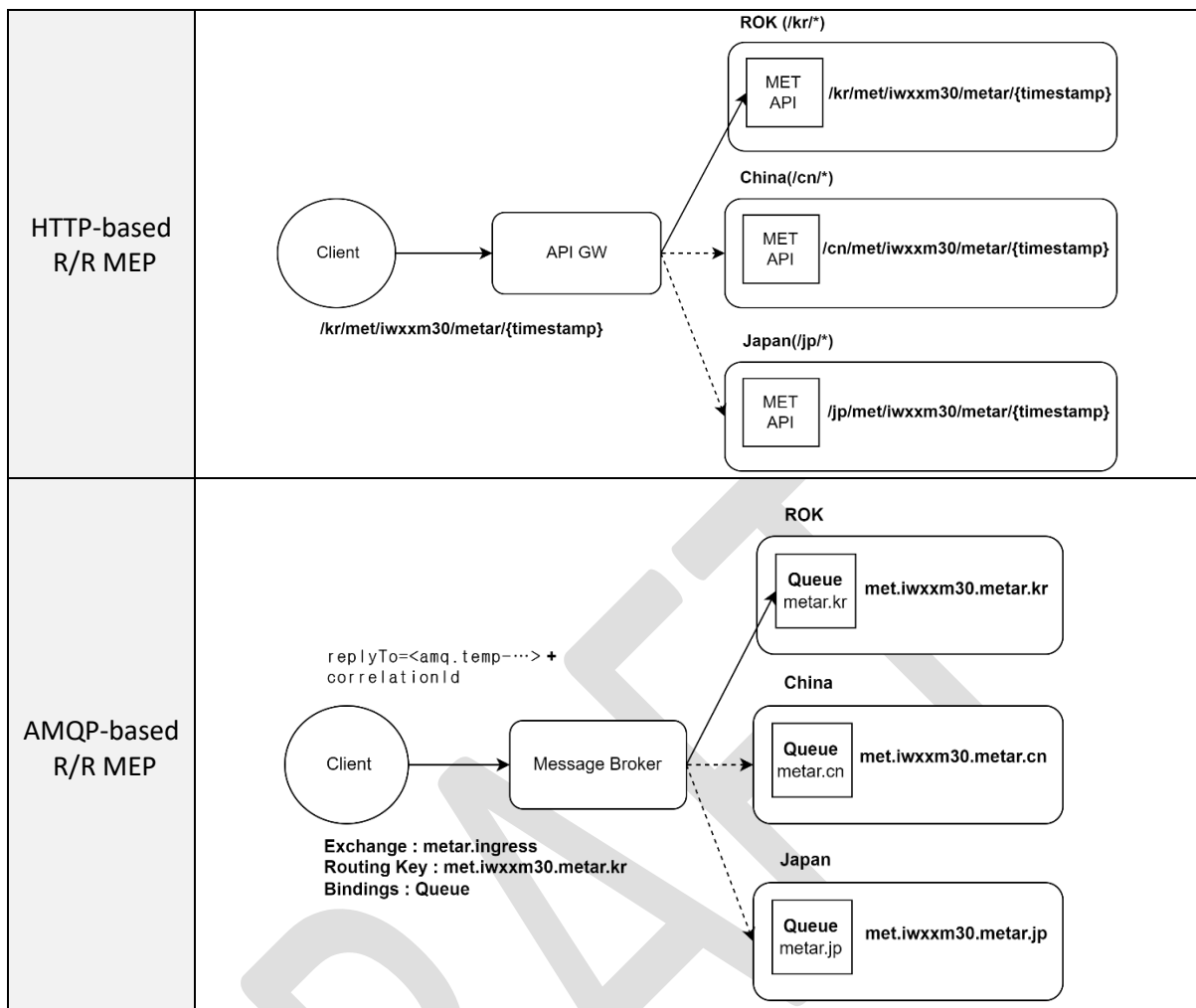

Diagram X. Diagram

- a. **Mechanism:** The requester specifies the region, service name, or function within the routing path or topic naming structure (e.g., (HTTP) `/kr/met/iwxxm30`, `/jp/met/iwxxm30`, or (AMQP) `met.iwxxm30.metar.kr`).
- b. **Advantages:**
  - Easy to implement and configure
  - High clarity and transparency, since routing is explicitly defined in the URL
  - Works well with both HTTP-based gateways and messaging systems that support topic-based or header-based routing.
- c. **Disadvantages (Consideration):**
  - Need to have commonly agreed naming convention for the routing path and topic
  - Front-facing path routing structure (e.g., URL or topic schema) need to be carefully designed; backend endpoints remain abstracted from requestor

## 7.1.2. Contents Based Routing

Content-based routing provides more flexibility by making routing decisions based on the message content (headers, parameters, or payload), rather than just the routing path or topic.

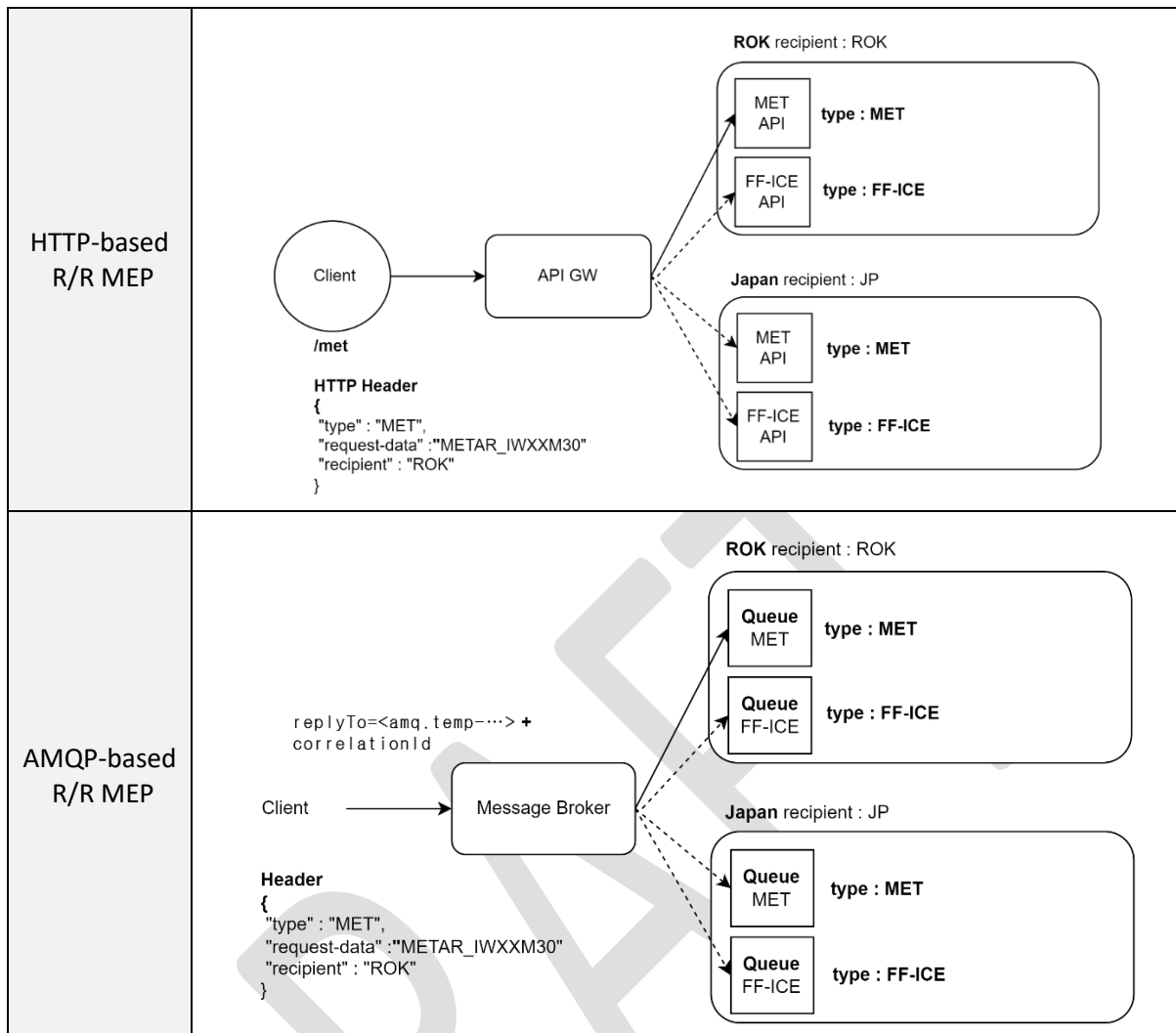

Diagram X. Diagram

- a. **Mechanism:** The requester sends a generic request while including additional routing information in headers or message body (e.g., type, request-data, and recipient). The API GW or message broker inspects the content and dynamically determines the correct destination.
- b. **Advantages:**
  - High flexibility in handling dynamic services
  - Decouples clients from internal routing logic; clients only need to know the front-facing service address, not the exact backend service.
  - Supports complex service ecosystems where routing depends on data attributes (e.g., airspace ID, flight identifier)
- c. **Disadvantages (Consideration):**
  - More complex to configure and manage.
  - Potential security risks such as injection attacks (e.g., malicious payloads in headers or message body) must be carefully mitigated through validation, sanitization, and strict policy enforcement.

- Inspection of the full message body is generally not permitted under ICAO provisions (e.g., Annex 15). Therefore, routing decisions should primarily rely on HTTP or AMQP headers or query parameters, rather than deep inspection of the payload.
- Routing decisions should therefore rely on standardized HTTP or AMQP headers or query parameters, rather than payload inspection.
- A commonly agreed set of routing-related headers should be established at the regional level to ensure consistency.

## 7.2. Approach on Routing Mechanism of R/R MEP in Asia/Pacific Region

For the Asia/Pacific SWIM environment, the following routing mechanism could be explored:

### ***Path- or Topic-Based Routing (PBR)***

Path-Based Routing is both applicable to HTTP-based API GW and AMQP-based message broker more consistent with the principles of REST API or topic design architecture

## **8. Any Other Considerations**

This document proposes approaches to implementing R/R MEP in the APAC region. Proof of Concept (POC) will be conducted to evaluate and select specific technologies after the POC is completed.

This document does not consider interoperability of R/R MEP between regions; this will be addressed in a later phase.

It also does not define the requirements for the API Gateway or the message broker to enable R/R MEP; these will be defined in a separate document.

## 9. Annexes

### 9.1. Annex 1 – Synchronous and Asynchronous R/R Data Flow Diagram

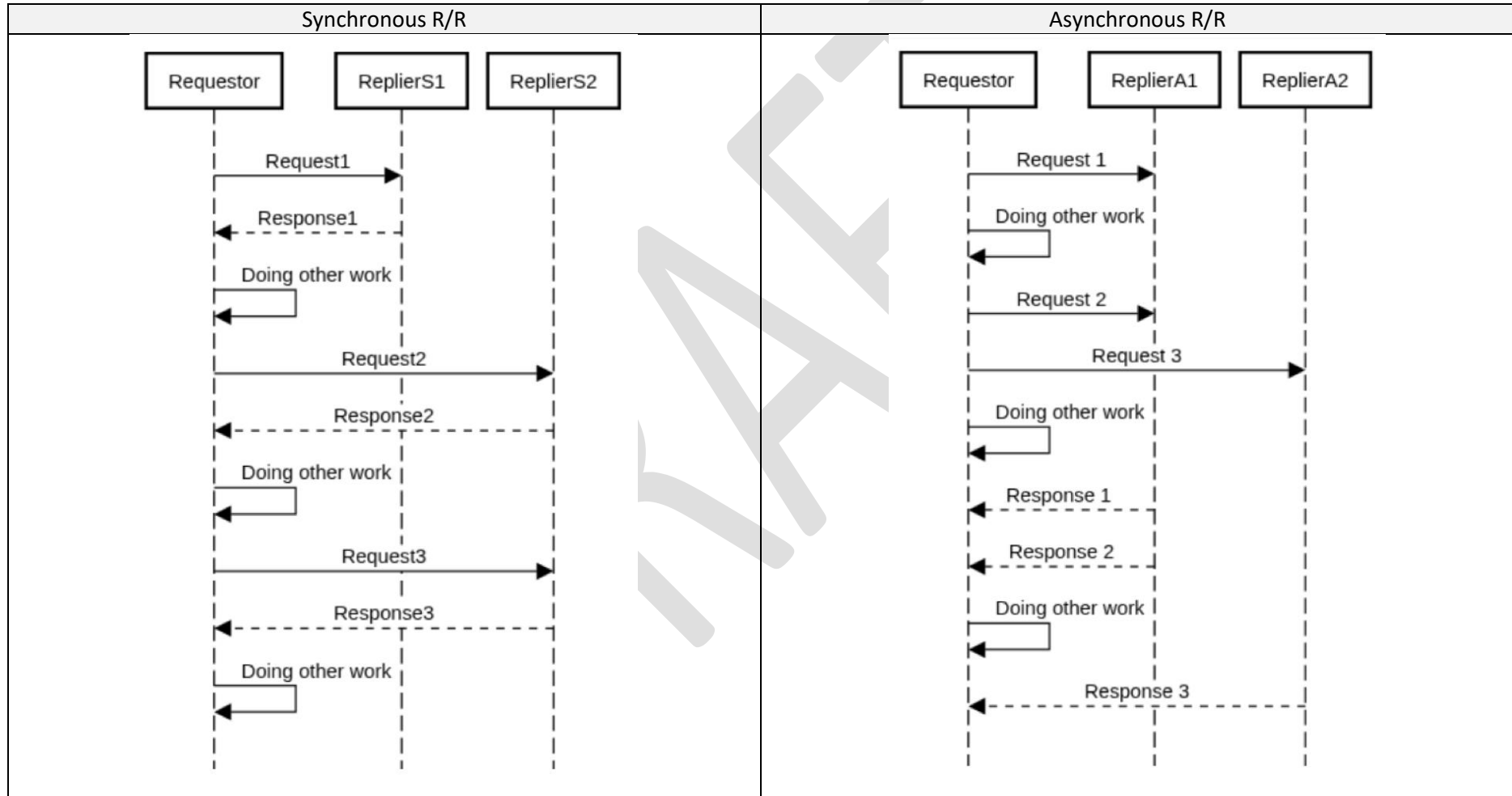

## 9.2. Annex 2 – Applicability of Synchronous and Asynchronous R/R MEP to FF-ICE Service

Service	MEP	Synchronous R/R	Asynchronous R/R	Note
GUFI Service	R/R	O	O	
FF-ICE Filing Service	P/S, R/R	X	O	Separate messages ought to be responded from replier (Submission Response + Filing Status)
FF-ICE Data Publication Service	P/S	-	-	
FF-ICE Trial Service	R/R	O	O	
FF-ICE Flight Data Request Service	R/R	O	O	
FF-ICE Notification	P/S, R/R	O	O	
FF-ICE Planning Service	P/S, R/R	X	O	Separate messages ought to be responded from replier (Submission Response + Planning Status)

\* FF-ICE services mentioned above are defined in the APAC SWIM Common Services (APAC Common SWIM Information Services, WP11, SWIM TF/10)

## 9.3. Annex 3 – FF-ICE Service Data Flow Diagrams of Synchronous and Asynchronous R/R MEP

## ● FF-ICE Trial Service

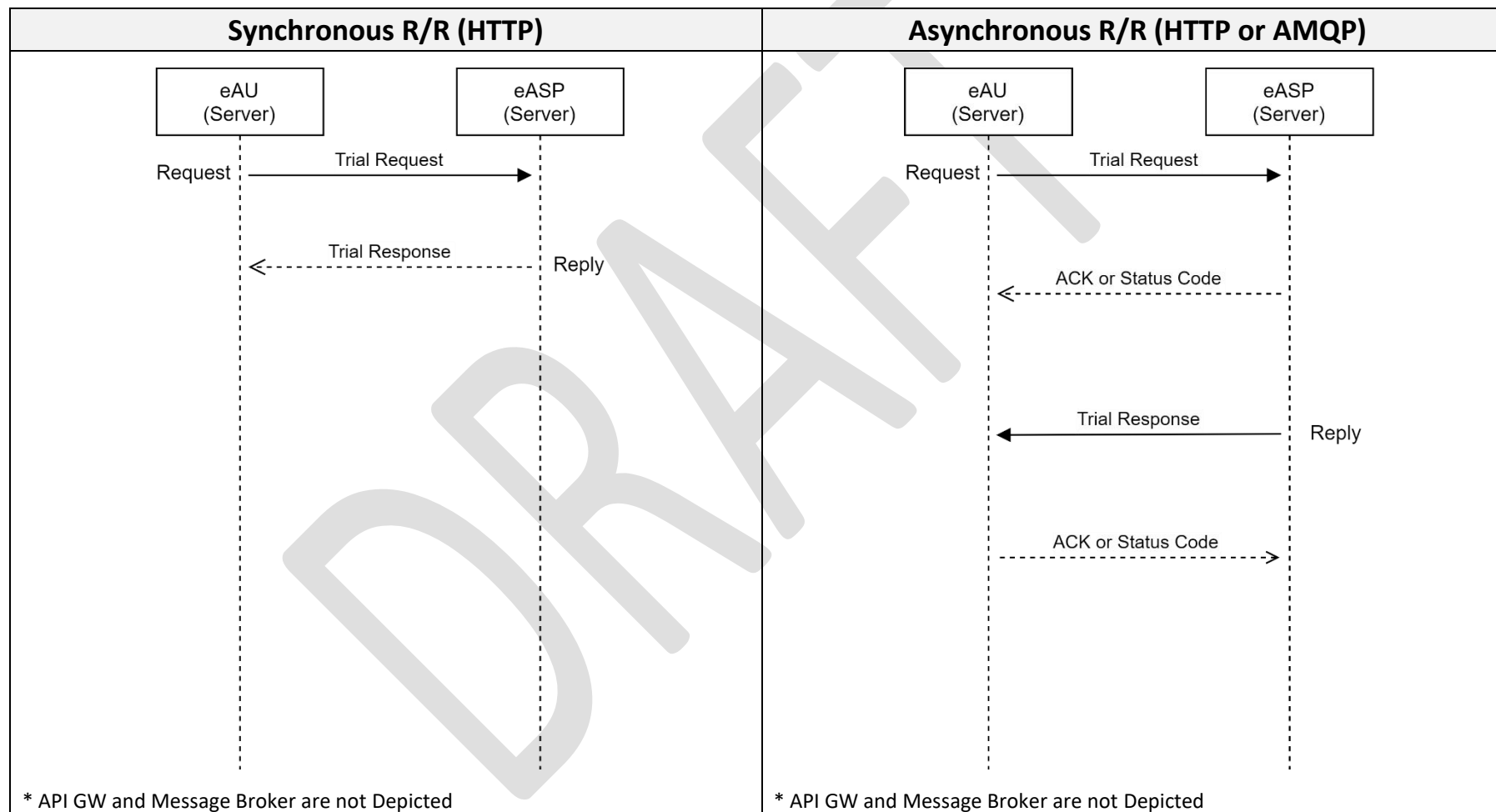

● FF-ICE Planning Service

