



# ICAO

*International Civil Aviation Organization*

**Fourth Meeting of the Asia/Pacific Air Traffic Management Automation System Task Force (APAC ATMAS TF/4)**

*Bangkok, Thailand, 28 – 30 June 2023*

Agenda Item 4: ATM Automation System Implementation Experience by States

4.2 Resilience consideration and contingency planning

### **New Air Traffic Management Automation System – Availability, Contingency, and Configuration**

(Presented by New Zealand)

#### **SUMMARY**

This paper details the needs that drove the enhanced availability, contingency and configuration capability of New Zealand's new Air Traffic Management Automation System – SkyLine-X

## **1. INTRODUCTION**

1.1 New Zealand's Air Navigation Service Provider (Airways) is soon replacing its existing Air Traffic Management Automation System (Skyline) with SkyLine-X. The new system represents a significant improvement in availability, contingency and configurability and more closely aligns New Zealand with ICAO, National and airspace user guidance.

1.2 The enhanced availability, contingency and configurability of the new system will support the preservation of service delivery to airspace users throughout technical failure or contingency events and allow more effective system development in support of the National Air Navigation Plan and Airways associated Operational Strategy.

## **2. DISCUSSION**

### ATMAS availability, contingency and configuration drivers

2.1 ICAO's Global Air Navigation Plan identifies Capacity, Flexibility, Predictability and Safety Key Performance Areas (KPA). Respectively, these KPA ambitions identify the need for:

- Continuous service availability through disruptive events
- The ability to absorb required business or operational changes in trajectory
- No increase in the variability of ANS service delivery
- Zero service-related accidents and a 50% reduction in service-related incidents

2.2 Doc 9882 (Manual on ATM System Requirements) goes on to identify the need to:

- Ensure that quality of service includes performance requirements related to availability, continuity, reliability, and integrity

- Ensure that the ATM system safety is maintained during any transition
- Establish contingency plans at all levels of operation to deal with anomalies/disruptions and to ensure safety and an appropriate level of operations
- The ATM system shall be implemented and operate in such a way that varying and diverse user requirements will be met as closely as technically possible within defined equity and access

2.3 New Zealand's Air Navigation Plan's key ATM objective is to move from air traffic controlling (Tactical) to air traffic enabling (Strategic). To achieve this objective, the following items are identified:

- Phasing in new systems and technology in a systematic and orderly fashion
- Identifying and mitigating risks associated with technology and process change
- Ensure that there are adequate contingencies in the event of system failure
- For surveillance services – ensure continuity of service can be maintained at international airports and main trunk routes

2.4 The national plan also highlights ATC (and by association the ATMAS) as the current coordination point for all air and ground operations and therefore subject to both national and international objectives for the ATMAS.

2.5 Airspace users also identified ATM system needs that reflected their business imperatives and obligations to support the national Air Navigation Plan. Primary of those needs were:

- Less intervention and greater predictability in flying planned operations
- Greater use of ATMAS tools to support TBO and facilitate optimal use of aircraft CNS and performance capabilities
- No interruption to the availability of Air Traffic Services for key airports/routes

2.6 Airways 2014-15 Operational Strategy factored in Regulatory and airspace user needs. The Strategy envisaged a migration from ATC service, with failure and contingency modes punctuated by periods of service reduction or unavailability, to ATM services with 100% systems and service availability and only capacity adjustments, based on the type of failure or contingent event. This migration was captured within the One System/Two Locations concept with the following primary workstreams enabling it:

- Common operations (processes and support tools)
- Enhanced system resilience (availability/development)
- Enhanced contingency
- Configuration flexibility

### Common Operations

2.7 Common operations conceptualised standardisation by sector type (Common TMA/Common En-route) using a common set of support tools aligned to the sector type's needs, e.g. all Approach sectors using the same airspace/procedures model and a common suite of Approach orientated tools. The combination of standardisation and support tools would be the primary driver in moving from ATC to ATM.

2.8 Delayed by the impact of COVID and the resulting re-scoping of the strategy, common operations is still identified as integral for moving to an ATM environment. Further detail is beyond the scope of this paper, but it will be a significant factor in achieving operational safety and efficiency goals as Airways defines its new strategy in 2023.

Enhanced system resilience (availability/development)

2.9 The current ATMAS has been in operation for 20 years. Assessment of Airways' Safety Management System database for technical events over that period identified several minor, and three significant service disruption events. Generally, technical disruptions related to hardware or functional failures, adaptation error, or network issues. Less than 10% related to software stability. It is important to note that the ATMAS was rarely the root cause of disruptions but was often impacted by them.

2.10 Minor events resulted in no or limited service disruption. For events that affected the ATMAS, the result was often the short-term use of alternative function or process e.g., moving to Surveillance Data Bypass (BYP), reversion to verbal co-ordination or proceduralised operational work-around.

2.11 Each significant service disruption event had a different primary cause, these were:

- Corrupt flight data resulting in ATMAS instability
- A configuration error resulting in an overloaded data network
- A power supply fault affecting the aeronautical telecommunication network

2.12 For Airways, the variance of fault source and system dependency, meant that for the new ATMAS, resilience would need to be implemented across all critical components – ATMAS, Voice Switch, networks, power etc. The 100% service availability requirement meant the ATMAS' architecture would need sufficient resilience to recover from problems and always be available. The ATMAS, as part of that architecture, would also need to support the desired availability.

2.13 For its Domestic and Oceanic ATMASs, Airways manages its own software development, adaptation, and update processes. Updates (adaptation and software) occur with every AIRAC cycle. If not scheduled to occur during low traffic periods, and without considerable procedural and resourcing requirements supporting them, current updating process would have the potential to cause significant operational impact.

2.14 Update scheduling is further complicated by the inclusion of a significant functional upgrade e.g., introducing new surveillance sensors. Managed as a project, such change usually has associated training and procedural change elements that require scheduling. If a desired implementation date conflicts with an already large update cycle, project enhancements are often deferred to a cycle with less potential impact, complicating project rollout. With many projects in motion at one time, implementation clashes are not uncommon – further exacerbating the issue.

2.15 To resolve its development issues, Airways desired a system that could be updated dynamically; de-linking its development roadmap updates from cycle changes so that as soon as a validated solution is available, it could be installed onto the live system for final validation and release when desired.

2.16 To support the desired resilience needs, the new ATMAS includes several key features:

- Distributed architecture. Each server application is split into multiple processes, each of which runs as a primary and secondary process on separate hardware.
- A multichannel system in which each channel runs as an individual ATMAS system mounted on virtualised machines and networks across the two centres. One channel acts as the master, with successfully processed data from that master synchronised across to the passive channels. This design means:
  - Severe technical failures are likely to be confined to one channel on its one virtual network, because of measures to reduce cross-channel common-mode failure

- Each channel processes inputs independently, potentially with different software and static data and operating system releases.
- Cyclic failure detection within the core servers. This feature means an input which results in a cyclic (common mode) process failure is quarantined.
- Cyclic failure detection within each workstation, limiting the impact of corrupted or unexpected input data by isolating the inputs when a workstation fails more than once within a preset period
- Server processes able to immediately restart with the last successfully processed data
- Core servers able to immediately restart with software-version independent persistent saved data
- Enhanced contingency configuration
- Enhanced power supply configuration
- Significantly improved cyber-security

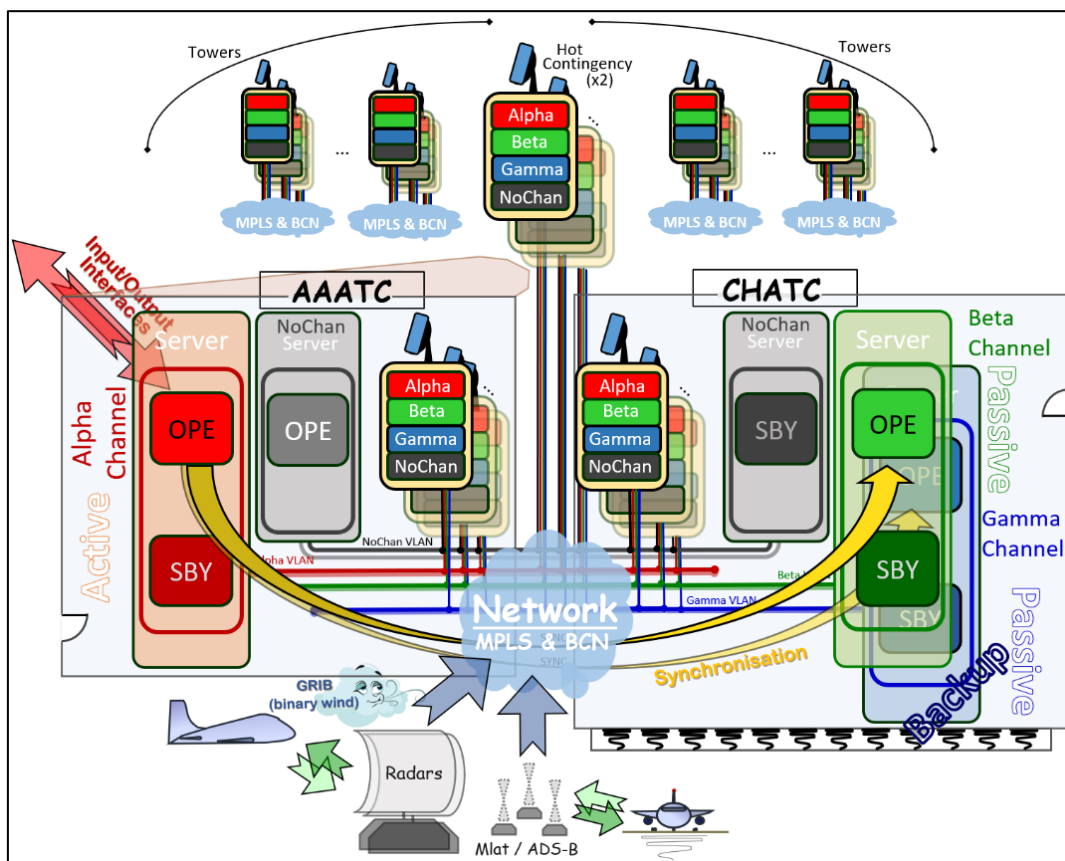

Fig 1. Multiple Channel Architecture

Enhanced contingency

2.17 The 2011 earthquakes highlighted the service availability risk of having most surveillance operations located in one Centre – Christchurch. One System/Two locations envisaged a single ATMAS servicing two physical Centres that would split day-to-day operations between them. In the event of the loss of one Centre, the other would have the availability, capacity, and configurability to take over.

2.18 To support One System/Two locations, the ATMAS design has several novel configuration and functional capabilities, including:

- Replication of physical Controller Work Positions (CWPs) at each Centre

- Replacement of multiple system-specific networks (routers, switches, etc.) with a sophisticated system-agnostic nation-wide network infrastructure
- Replication of supporting ATM systems at each Centre
- Each CWP has identical capabilities and is immediately configurable to exercise any set of airspace or functionality via Sector/Airspace Role allocation
- Sector mirroring functionality to facilitate ‘dual control’ for remote Transfer of Control/Radio guard between positions in separate Centres
- Voice Control Switch (VCS) role following with ATMS Sector allocation
- Multiple channel architecture as described in 2.16. With network capability to support reconfiguration, the loss of a Centre will not eliminate system availability at other sites including contingency facilities

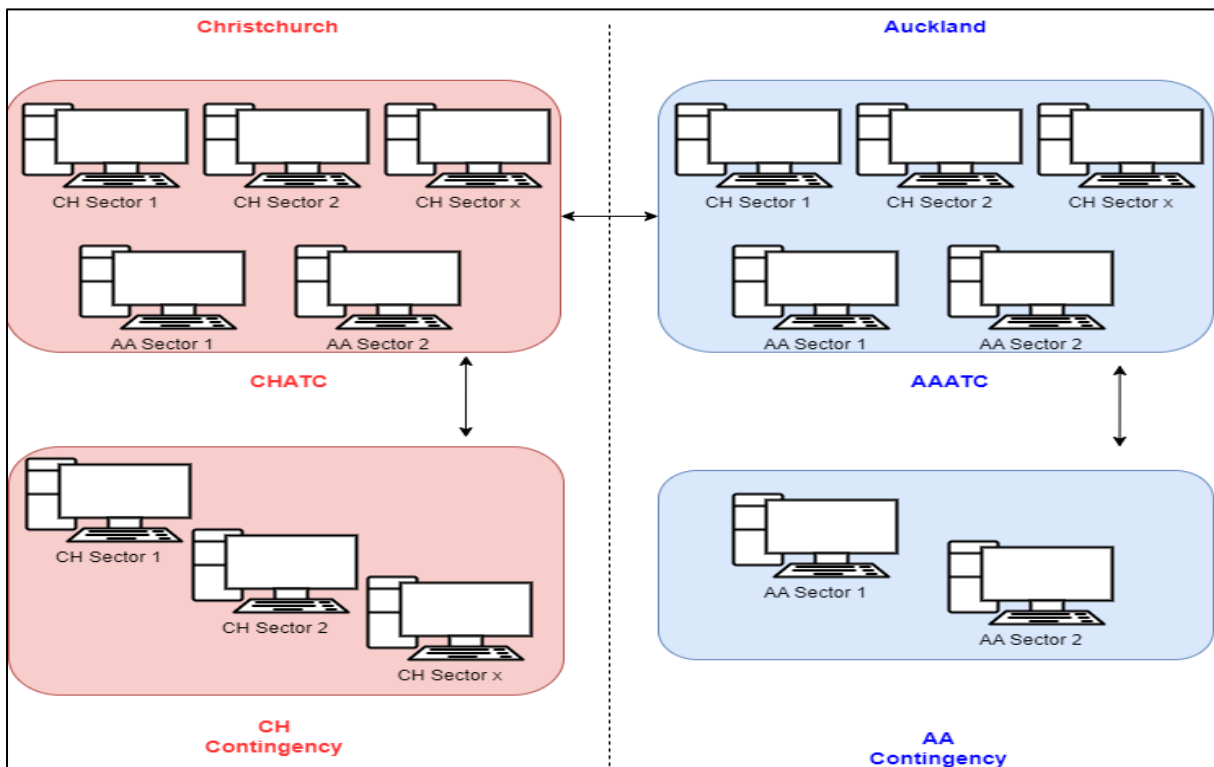

Fig. 2 – Overview of the final configuration of the new ATMAS including Local contingencies

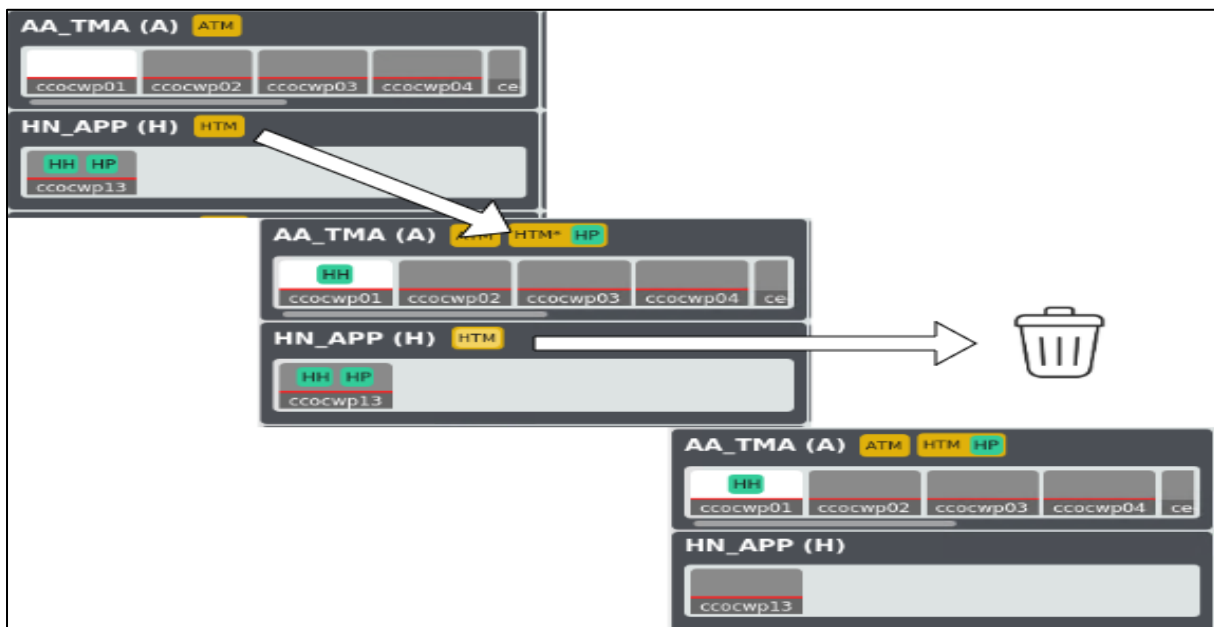

Fig.3 Example of Sector mirroring management from the SkyLine-X Control Room window

2.19 With common operations delayed by the impact of COVID, the bulk of domestic operations remain in Christchurch and the current staffing numbers of the Auckland Centre cannot support the desired contingency service level envisaged for One System/Two Locations. As a result, in 2022 two additional Local Contingency (LC) facilities were stood up to support continuous operations in the case of the loss of either main Centre. These additional contingencies required re-configuration of the ATMAS (primarily CWP additions and mirroring of supporting ATS systems required for each contingencies' calculated operational capacity).

Configuration flexibility

2.20 As demonstrated by the need for additional contingency facilities, configuration flexibility is essential for the new ATMAS. With a re-set of Airways Strategy this year, further ATMAS re-configuration is expected as the result of road-mapped sectorisation reviews and the resumption of investigation into common operations.

- 2.21 New Functionality implemented to support enhanced configuration include:
- Review and enhancement of the SkyLine-X adaption tool
  - Additional adaptation features to support the availability and contingency functionality previously mentioned
  - Ingestion of geographic data in AIXM format each AIRAC cycle
  - Use of multi-channel to support dynamic development, simpler release processes and project function implementation timeframes

2.22 It is important to highlight that to support the configuration flexibility desired by Airways, having its own adaptation and software development teams and development lab facilities that mirror the live environment is crucial. Beyond the regular AIRAC updates, this capability supports project workshopping and prototyping activities to test proposed configuration before operational application and facilitates operational changes in the timeframes required. The capability also manages adaptation and software changes, their integration, testing and validation activities, and then the final build creation and deployment activities

**3 ACTION BY THE MEETING**

- 3.1 The meeting is invited to:
- a) note the information contained in this paper; and
  - b) discuss any relevant matter as appropriate

-----