



ICAO UNITING AVIATION

NO COUNTRY LEFT BEHIND



Introduction to Mode S Secondary Surveillance Radar System

CHEN Yang (Isaac)
CAAC ATMB
isaac21@qq.com





Content

- **1. Mode S operations**
 - a) Dialogue between Mode S Interrogator and Transponder
 - b) II & SI code
 - c) Acquisition and Lockout protocols
 - d) Mode Interlace Pattern & Optimal interrogation sequence
 - e) Time and Power constraint of the interrogator
- **2. ELS & EHS**
 - a) Operational requirements of ELS & EHS
 - b) Register introduction
 - c) Optimal register extraction
- **3. Mode S transponder**
 - a) Basic electrical specification
 - b) Interrogation acceptance & Lockout protocols
- **4. Flight inspection for a Mode S radar**
- **5. APAC's proposed modifications to Doc. 9924**



ICAO UNITING AVIATION

NO COUNTRY LEFT BEHIND



Mode S operations





Mode S operations-- Dialogue between Mode S Interrogator and Transponder History & Advantage

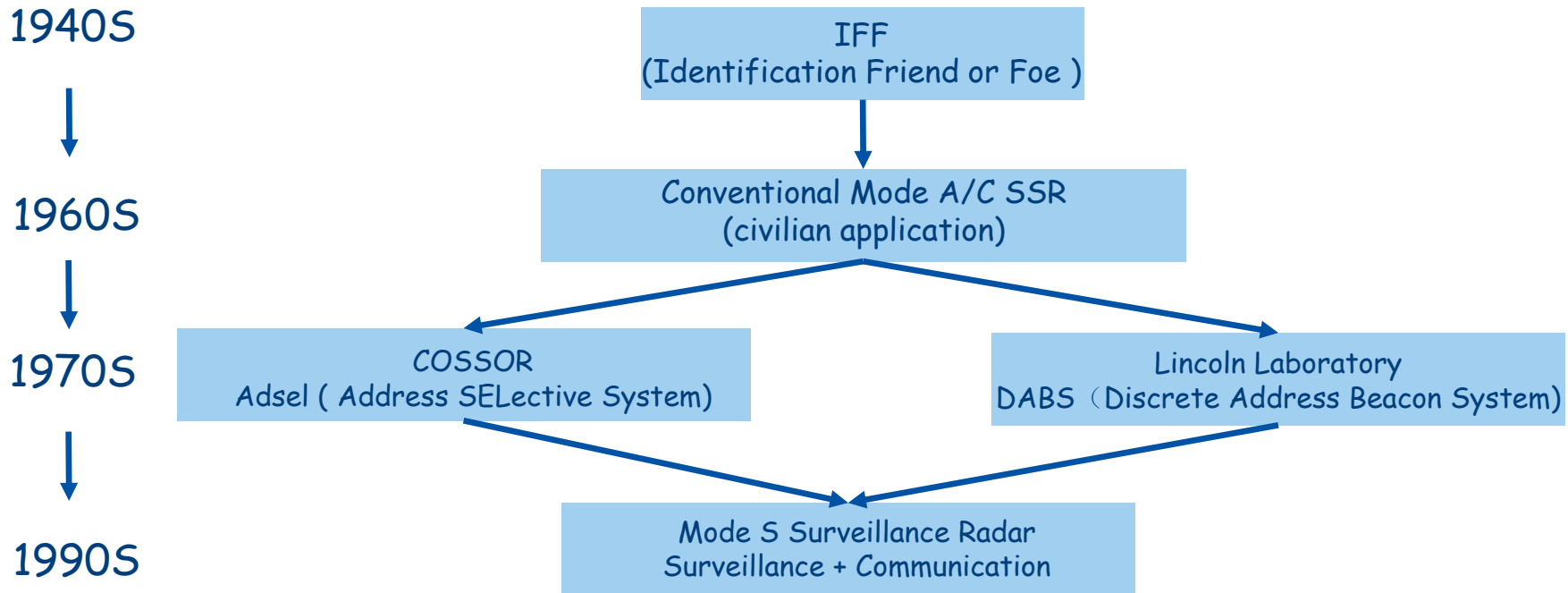

The advantage

- Compatible to the secondary surveillance radar (SSR)
- Better performances in degarbling & defruit
- Protection against transmission errors by a cyclic redundancy check
- Enhanced communication to collect on board information (BDS Information)





Mode S operations-- Dialogue between Mode S Interrogator and Transponder

Mode AC Interrogation

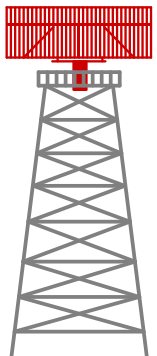
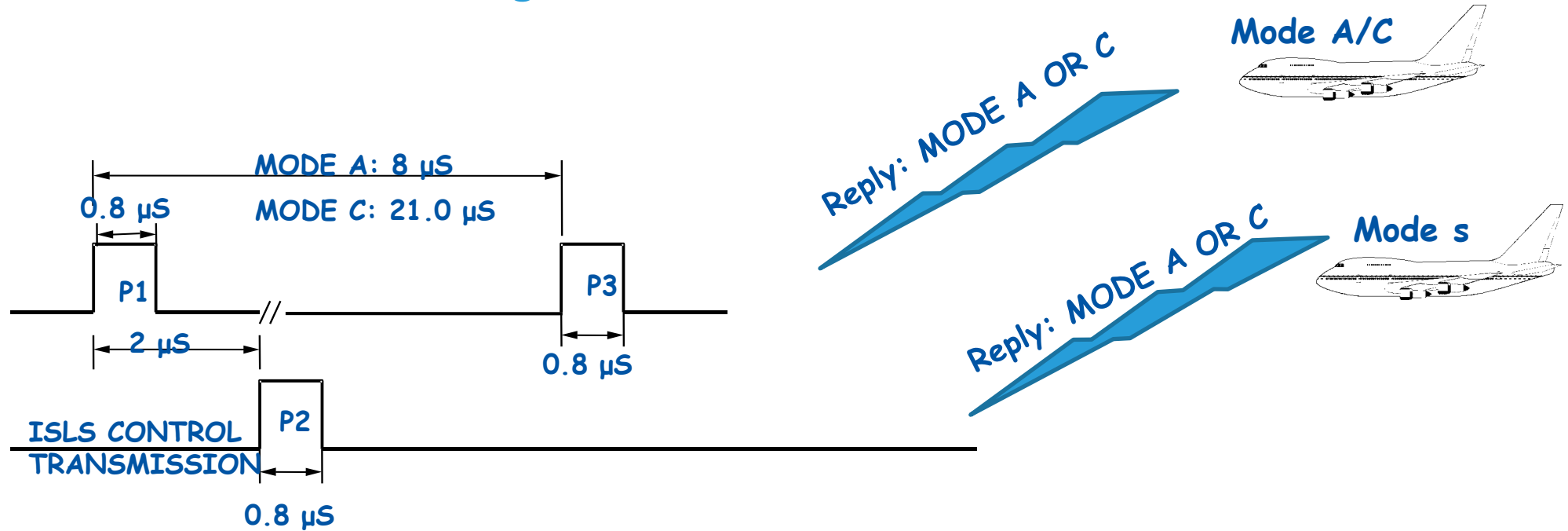

| Interrogation | Mode AC Transponder | Mode S transponder |
|---------------|---------------------|--------------------|
| P1-P3 8μS | Mode A | Mode A |
| P1-P3 21μS | Mode C | Mode C |



Mode S operations-- Dialogue between Mode S Interrogator and Transponder Inter-Mode Interrogation

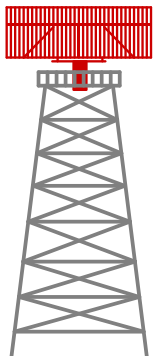
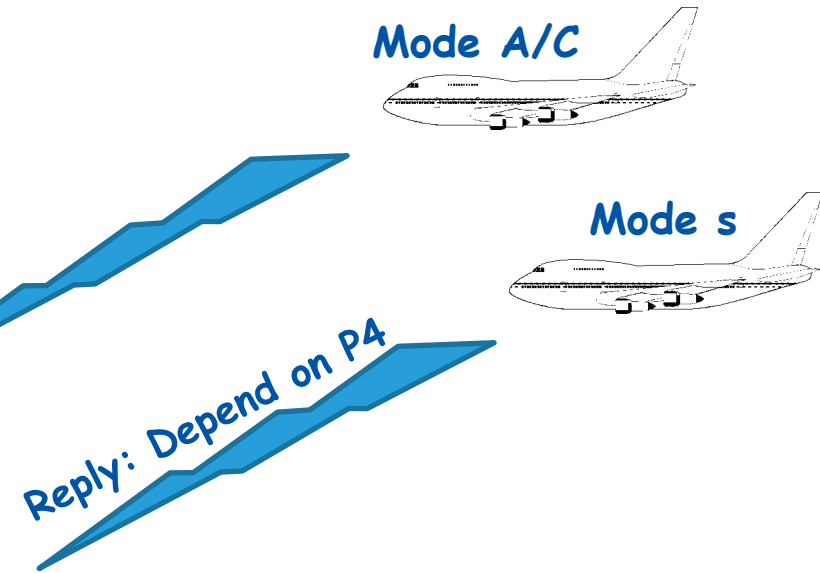
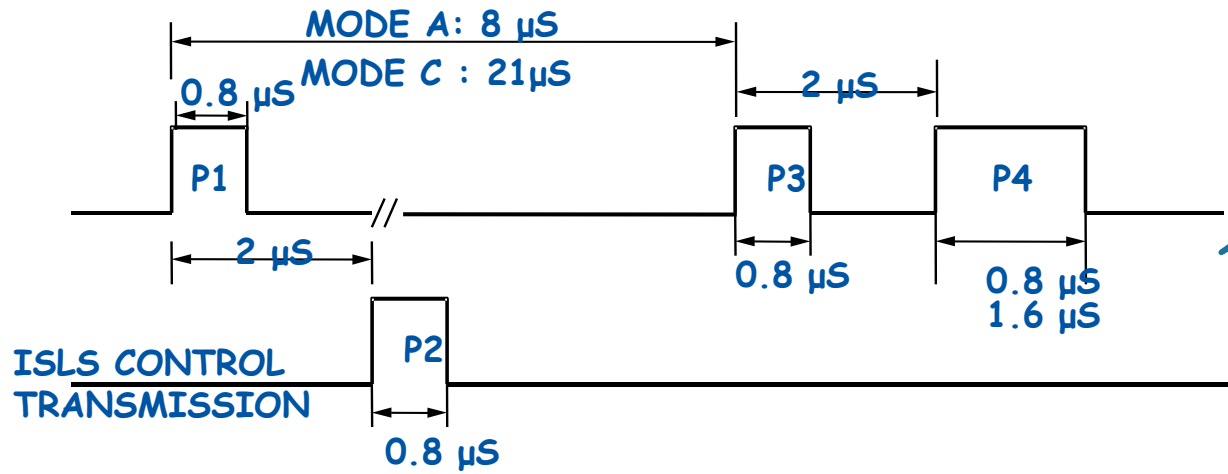

| Interrogation | Mode AC Transponder | Mode S transponder |
|--|---------------------|---------------------|
| Mode A/C/S all-call P4 =1.6 μs | Mode A/C | DF11 with II=0 & AA |
| Mode A/C-only all-call P4 =0.8 μs | Mode A/C | No reply |



Mode S operations-- Dialogue between Mode S Interrogator and Transponder

Mode S Interrogation

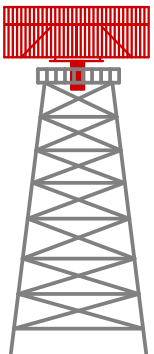
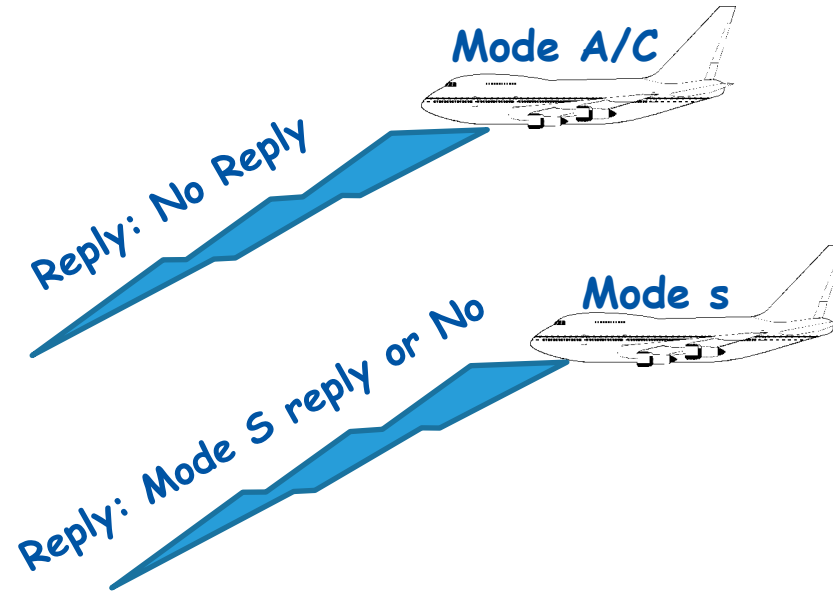
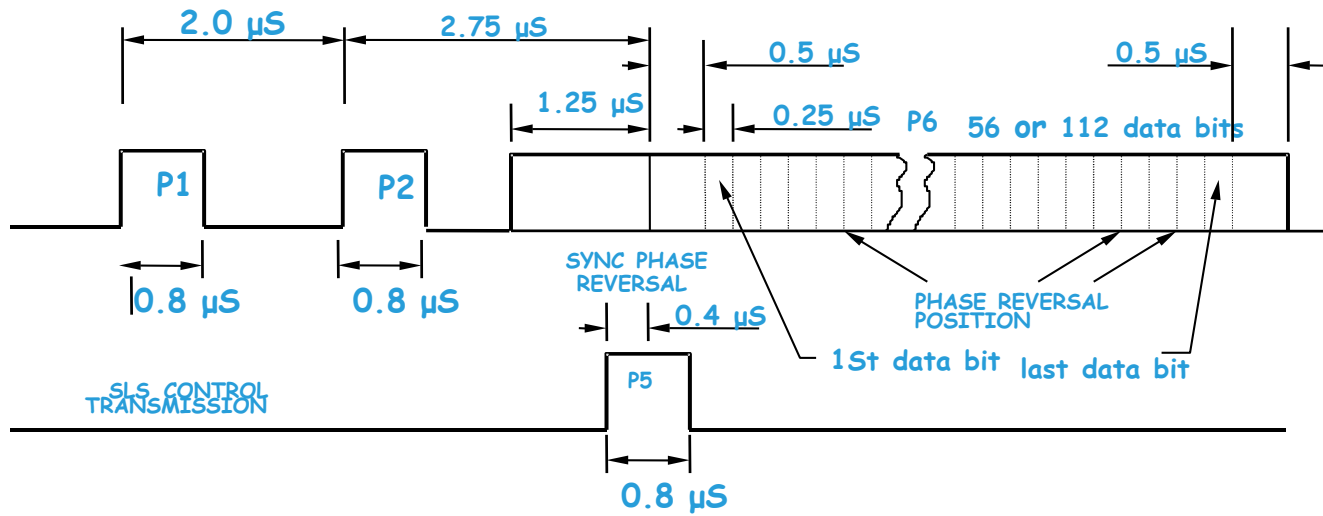

| Interrogation | Mode AC Transponder | Mode S transponder |
|---------------|---------------------|--------------------------|
| Mode S | No Reply | Mode S reply or No Reply |



Mode S operations-- Dialogue between Mode S Interrogator and Transponder

Interrogation Modulation and Coding Design

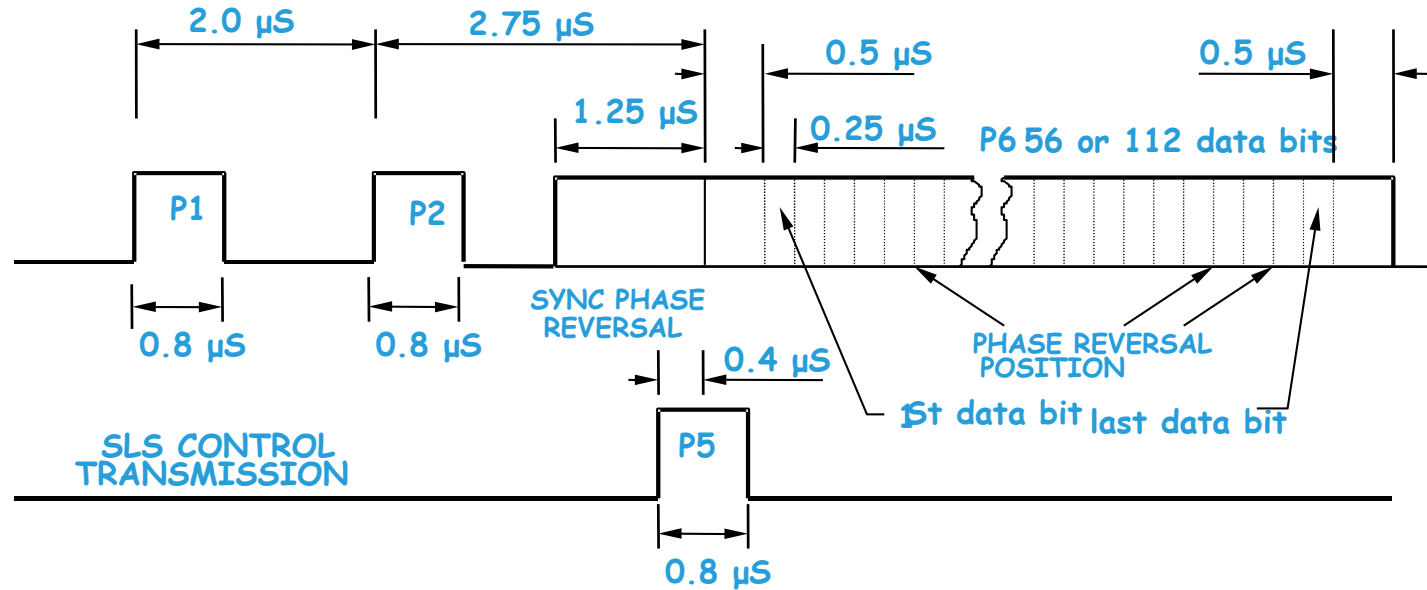

Uplink design philosophy

- P1—P2 pulse ----- suppression of Mode A/C transponder.
- 56-112 bit information. $P6 = 16.25 - 30.25 < 35 \mu S$
- Mode S data lie within in the Mode A/C suppression interval ($35 \mu S$).
- $1 \text{ bit} / 0.25 \mu S \rightarrow 4 \text{ MHz} + \text{BDPSK} \rightarrow 8 \text{ MHz Bandwidth}$.
- 2 MHz -----Need two segments, 8 MHz -----Not compatible with receiver bandwidth.



Mode S operations-- Dialogue between Mode S Interrogator and Transponder Reply Modulation and Coding Design

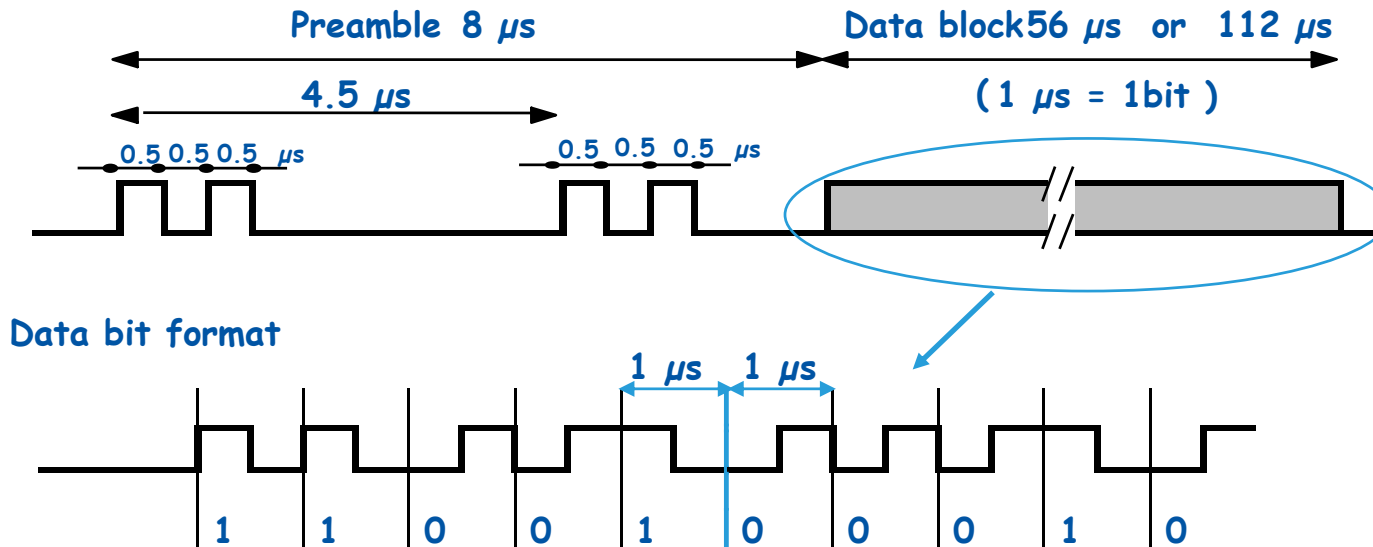

Downlink design philosophy

- The four pulse preamble is designed to be easily distinguished from Mode AC replies.
- PPM : The absence of interference results in received energy in only one half of the interval. Thus energy in both halves indicates that an interfering pulse was received at the same time.
- PPM : results in a constant number of pulses in each reply, assuring sufficient pulses for an accurate monopulse angle estimate.



Mode S operations-- Dialogue between Mode S Interrogator and Transponder

All Call Reply - Downlink Format 11

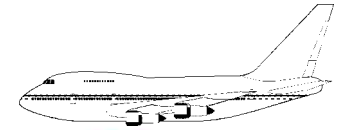

DF : Downlink Format

CA : Capability

AA : Address Announced

PI : Parity / Interrogator Identifier

Mode S acquisition

Mode S only - All Call Interrogation - Uplink Format 11

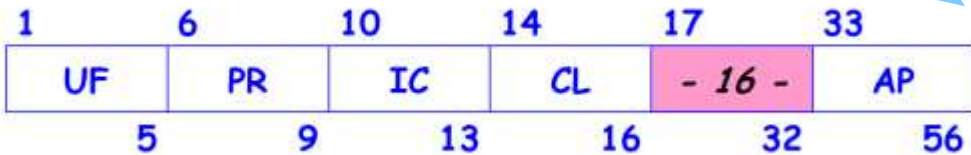

UF : Uplink Format

PR : Probability of Reply

IC : Interrogator Code

CL : Code Label

Spare : 16 bits

AP : Address / Parity

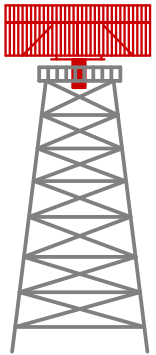



Mode S operations-- Dialogue between Mode S Interrogator and Transponder UF11

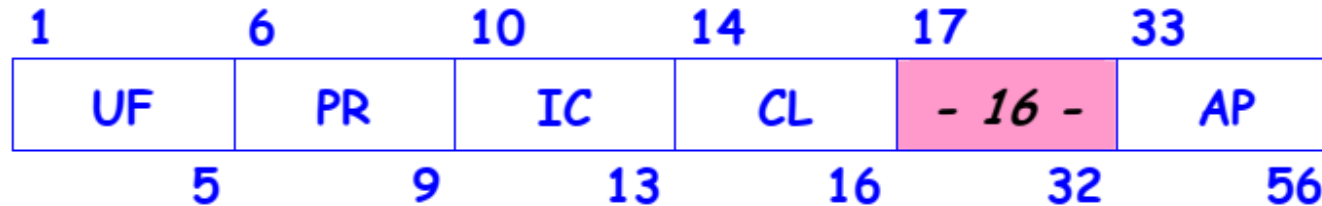

- UF = uplink format (01011; Decimal value 11)
- PR = probability of reply (related to Stochastic acquisition & Lockout Override)
- IC = interrogator code:
- CL = code label
- AP = address/parity:



Mode S operations-- Dialogue between Mode S Interrogator and Transponder UF11 PR

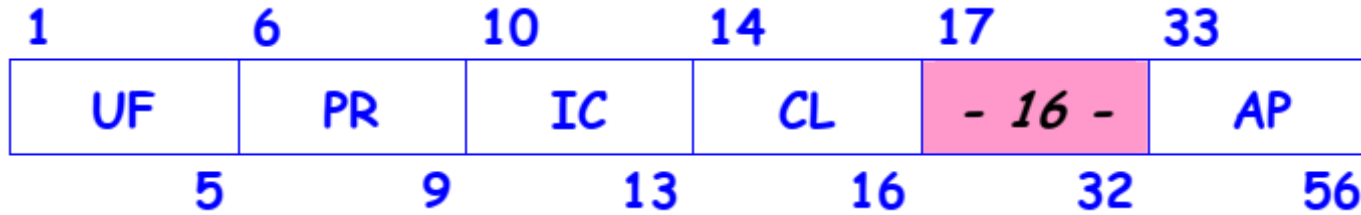

PR : Probability of Reply (4 bits)

| | | |
|------------|--|-------------------------------|
| 0 | Reply with probability of 1 | Stochastic Acquisition |
| 1 | Reply with probability of 1/2 | |
| 2 | Reply with probability of 1/4 | |
| 3 | Reply with probability of 1/8 | |
| 4 | Reply with probability of 1/16 | |
| 5, 6, 7 | Not assigned | Lockout Override |
| 8 | Disregard Lockout , reply with probability of 1 | |
| 9 | Disregard Lockout , reply with probability of 1/2 | |
| 10 | Disregard Lockout , reply with probability of 1/4 | |
| 11 | Disregard Lockout , reply with probability of 1/8 | |
| 12 | Disregard Lockout , reply with probability of 1/16 | |
| 13, 14, 15 | Not assigned | |

For example, if PR =1, the transponder generate a random number between 0 and 1 and will reply only if:

- a) a lockout condition does not apply; and
- b) the generated random number is less than or equal to 0.5

If PR =9, the transponder generate a random number between 0 and 1 and will reply if

- a) Disregard the lockout state, generated random number is less than or equal to 0.5



Mode S operations-- Dialogue between Mode S Interrogator and Transponder UF11 PR

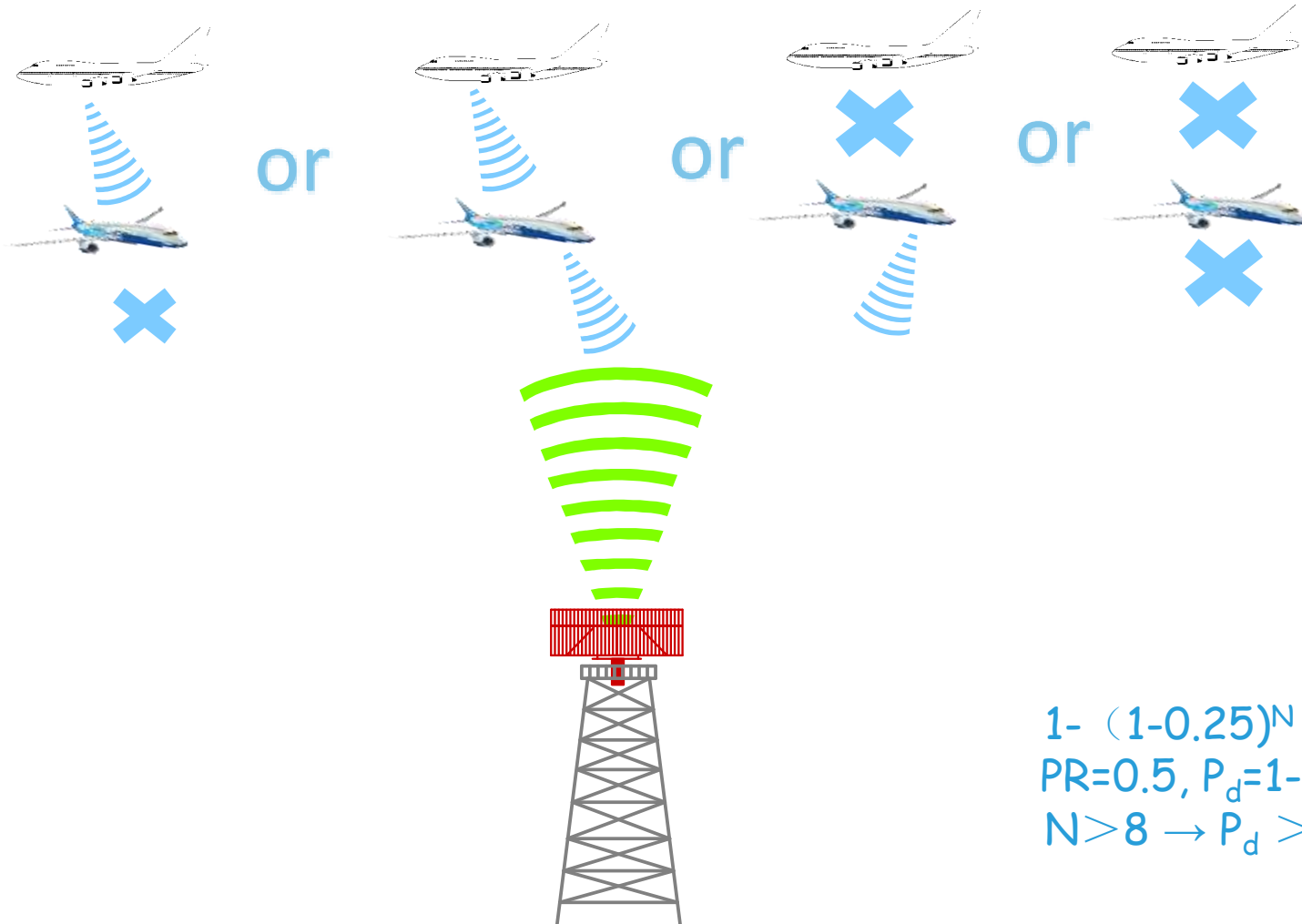

$$1 - (1 - 0.25)^N$$

$$PR = 0.5, P_d = 1 - 0.75^N,$$

$$N > 8 \rightarrow P_d > 90\%$$



Mode S operations-- Dialogue between Mode S Interrogator and Transponder UF11 PR

| Number of aircraft in garble zone | Acquisition Stochastic probability | | |
|-----------------------------------|------------------------------------|-------|-------|
| | 0.5 | 0.25 | 0.125 |
| 2 | 16 | 22 | 40 |
| 3 | 35 | 31 | 46 |
| 4 | 72 | 41 | 53 |
| 5 | > 100 | 56 | 61 |
| 6 | | 76 | 70 |
| 7 | | > 100 | 80 |
| 8 | | | 93 |
| 9 | | | 105 |
| 10 | | | 121 |

- This table from *Appendix H ICAO Doc 9924, 3rd Edition* shows the number of all-call interrogations required for 99 percent probability of acquisition.
- For a Mode S all call, the size of the garble zone is 5.18 Nm according to the length of the DF11 reply.



Mode S operations-- Dialogue between Mode S Interrogator and Transponder UF11 IC & CL

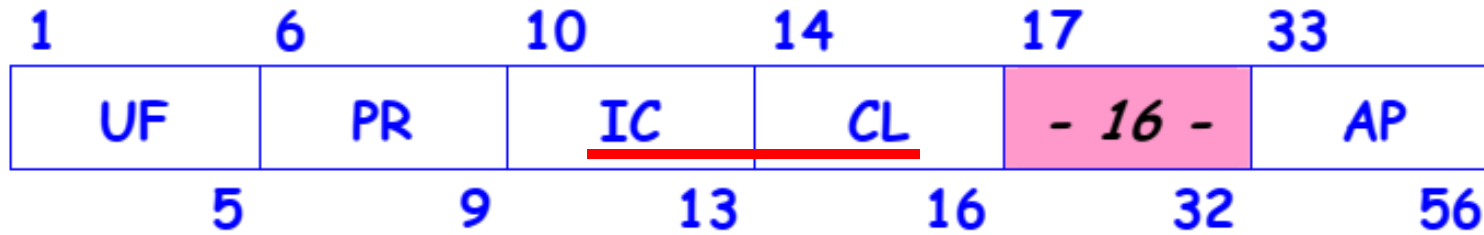

- IC (interrogator code):
The 4 bits contain the interrogator identifier or the last four bits of the surveillance identifier (SI).
- CL = code label :
If CL = 000, the information in the IC field is the interrogator identifier.
If CL = 001 to 100 (decimal value 1 to 4), the information in the IC field contains the last four bits of the SI.
- II 0-15/ SI 1-63

Note: A Mode S II-only transponder will ignore the CL field. A Mode S II-only interrogator cannot set the CL field and defaults to "000"



Mode S operations-- Dialogue between Mode S Interrogator and Transponder

UF11 AP

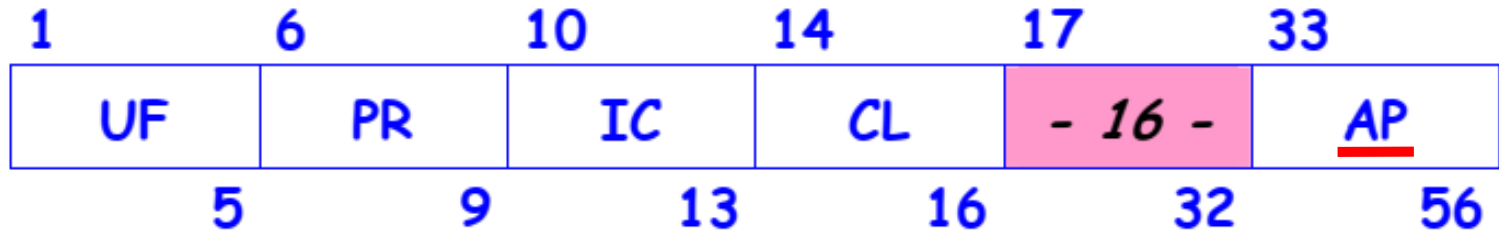

- For a UF11, the address consists of 24 one's, on which the parity is overlaid.
- The bits in AP (Address/parity) field are calculated by the first 32 information bits of UF11, broadcast aircraft address and generator polynomial. For the all-call interrogation, the aircraft address here use 24 ones.



Mode S operations-- Dialogue between Mode S Interrogator and Transponder UF11 AP

Up Link AP Coding

- $M(x)$ =Message $A(x)$ =Aircraft Address =ICAO 24-bit Address
- $G(x)=1 + x^3 + x^{10} + x^{12} + x^{13} + x^{14} + x^{15} + x^{16} + x^{17} + x^{18} + x^{19} + x^{20} + x^{21} + x^{22} + x^{23} + x^{24}$
- $x^{24} M(x)/G(x)=m(x)+R(x)/G(x) \rightarrow R(x)=\text{remainder}\{x^{24} M(x)/G(x)\}$
- $A(x) G(X)/ x^{24}=Q(x)+ r(x)/x^{24} \rightarrow r(x)=\text{remainder}\{A(x) G(X)/ x^{24}\}$

$$AP(X)= R(x)+A(x) G(X)/ x^{24} +r(x)/ x^{24}$$

$$T(X)=x^{24} M(x)+R(x)+A(x) G(X)/ x^{24} +r(x)/ x^{24}$$



Decoding

$$x^{24} T(X)/G(X)= x^{24} \left[\frac{x^{24} M(x)+R(x)+A(x) G(X)}{x^{24}} + \frac{r(x)}{x^{24}} \right] /G(X)$$

$$= x^{24} \frac{m(x)+A(x)+ r(x)}{G(X)}$$

High order bits



low order bits-
the last 24bits

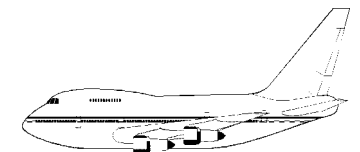



Mode S operations-- Dialogue between Mode S Interrogator and Transponder

UF11 AP

Example :

The task: Transmission 1011001, $G(x)=X^4+X^3+1$, $AA(X)=1001$

$$M(x)=1011001 \rightarrow x^6+x^4+x^3+1;$$

$$G(x)=11001=x^4+x^3+1=G(x) \text{ ----- CCITT CRC-4}$$

$$R\{x^4 * M(x) / G(x)\} = x^3+x = 1010 \rightarrow \text{Remainder}$$

$$AA(x)=1001=x^3+1 \quad AA(x)G(x) / x^4 = Q(x)+r(x) / x^4 = (x^3+x^2+1)+1/x^4$$

Transmission: $T(X) = x^4 M(x)+R(x)+AA(x) G(X) / x^4 +r(x) / x^4$
 $= x^{10}+x^8+x^7+x^4+x^2+x+1$
 $= 10110010111$



Mode S operations-- Dialogue between Mode S Interrogator and Transponder UF11 AP

Receive:

$$\begin{aligned}x^4 T(X)/G(X) &= x^4 \left[x^4 M(x)+R(x)+A(x) G(X)/ x^4 +r(x)/ x^4 \right] /G(X) \\&= \underline{x^4 m(x)} + \underline{A(x)} + r(x)/G(X) \\&= \underline{x^{10}+x^9+x^7+x^5+x^3+1} + 1/(x^4+x^3+1)\end{aligned}$$

1001

Summary: The $A(x)$ is modulo 2 with $G(x)$, then take the high 24 bits, perform modulo 2 operation with the remainder of $M(x)$ divided by $G(x)$ to obtain AP.



Mode S operations-- Dialogue between Mode S Interrogator and Transponder

UF11 Interrogation Rate

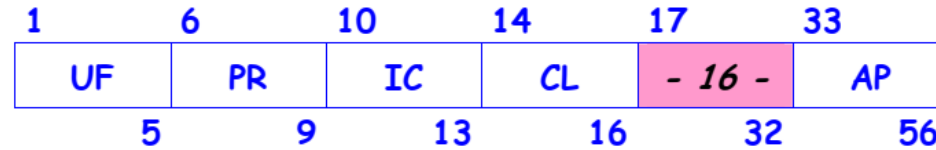

- The interrogation repetition rate for the Mode A/C/S all-call, used for acquisition, shall be less than 250 per second. This rate shall also apply to the paired Mode S-only and Mode A/C-only all-call interrogations used for acquisition in the multisite mode.

-----3.1.2.11.1.1 ICAO Annex 10 Volume 4, Fifth Edition

- A Mode S interrogator shall not trigger, on average, more than 6 all-call replies per period of 200 ms and no more than 26 all-call replies counted over a period of 18 seconds.

-----3.1.2.11.1.2 ICAO Annex 10 Volume 4, Fifth Edition

- 4-second per scan, beam width=2.4° (3dB) , All-Call rate ≤225 Hz;
4-second per scan, beam width=4° (effective beam width) All-Call rate ≤135 Hz



Mode S operations-- Dialogue between Mode S Interrogator and Transponder DF11

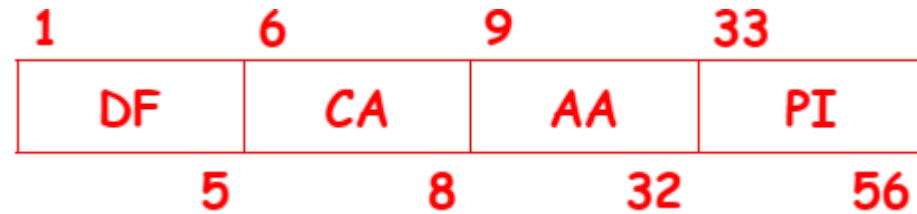

- DF = downlink format (01011; decimal value 11)
- CA = Capability (airborne or on ground , level 1 or above, DR ≠ 0 ?, FS alert →FS=2,3,4 or 5)
- AA = ICAO 24 bits
- PI = IC/parity



Mode S operations-- Dialogue between Mode S Interrogator and Transponder DF11

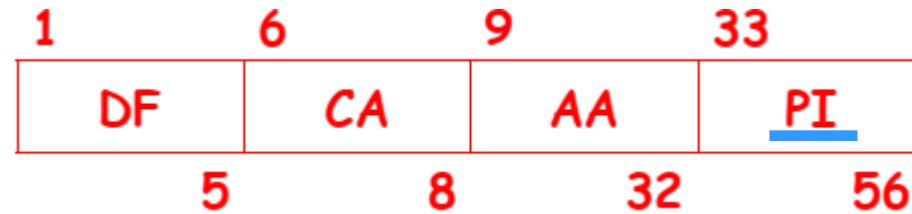

- $PI = 17 \text{ zero} + CL (3 \text{ bits}) + IC (4 \text{ bits}) = PI(x)$

Transponder --- Transmission: $T(x) = x^{24} M(x) + R(x) + PI(x)$

Radar---Reception : $[x^{24} M(x) + R(x) + PI(x)] / G(x) = Q(x) + 0 + [PI(x) / G(x)]$

The remainder = $PI(x)$



Mode S operations-- Dialogue between Mode S Interrogator and Transponder UF4 DF4 DF20

Surveillance , Altitude Request - Uplink Format 4

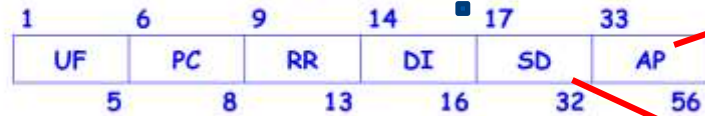

UF : Uplink Format
 PC : Protocol
 RR : Reply Request
 DI : Designator Identification
 SD : Special Designator
 AP : Address / Parity



Up link AP

Lockout command

Surveillance , Altitude Reply - Downlink Format 4



DF : Downlink Format
 FS : Flight Status
 DR : Downlink Request
 UM : Utility Message
 AC : Altitude Code
 AP : Address / Parity

Comm-B broadcast or AICB Application

Up link AP

Comm-B , Altitude Reply - Downlink Format 20



DF : Downlink Format
 FS : Flight Status
 DR : Downlink Request
 UM : Utility Message
 AC : Altitude Code
 MB : Message , Comm-B
 AP : Address / Parity

BDS information

RR=18 BDS 2,0

RR=17 BDS 1,0

RR=16 AICB

Others: RR+RRS(subfield in SD)

Up link AP

Downlink AP coding is different from Uplink, but similar to PI. Just replace PI (X) with A(X).



Mode S operations-- Dialogue between Mode S Interrogator and Transponder UF5 DF5 DF21

Surveillance , Identity Request - Uplink Format 5

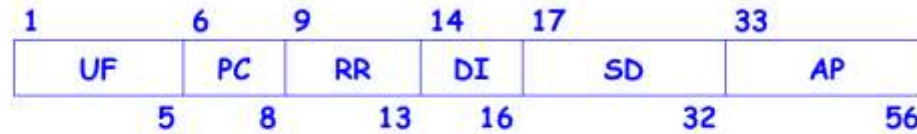

- UF : Uplink Format
- PC : Protocol
- RR : Reply Request
- DI : Designator Identification
- SD : Special Designator
- AP : Address / Parity

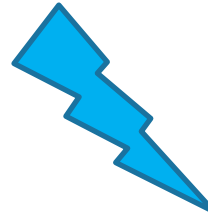

Surveillance , Identity Reply - Downlink Format 5



- DF : Downlink Format
- FS : Flight Status
- DR : Downlink Request
- UM : Utility Message
- ID : Identity
- AP : Address / Parity

Comm-B , Identity Reply - Downlink Format 21



- DF : Downlink Format
- FS : Flight Status
- DR : Downlink Request
- UM : Utility Message
- ID : Identity
- MB : Message , Comm-B
- AP : Address / Parity



Mode S operations-- Dialogue between Mode S Interrogator and Transponder Generation Polynomial

- $G(x) = x^{24} + x^{23} + x^{22} + \dots + x^{13} + x^{12} + x^{10} + x^3 + 1$
- It can detect any 24-bit error burst over any length of the bits-window.
- Hamming Distance=6, It can correct random error of length smaller than 5.
- It can correct burst-error of length 12.or 12 burst-error in any 24 bits window.

12 = 4 PULSE A + 4 PULSE B + 4 PULSE C + 4 PULSE D

Related to the interval between the F1 pulse and the SPI pulse of the MODE AC reply (24.65 μS)

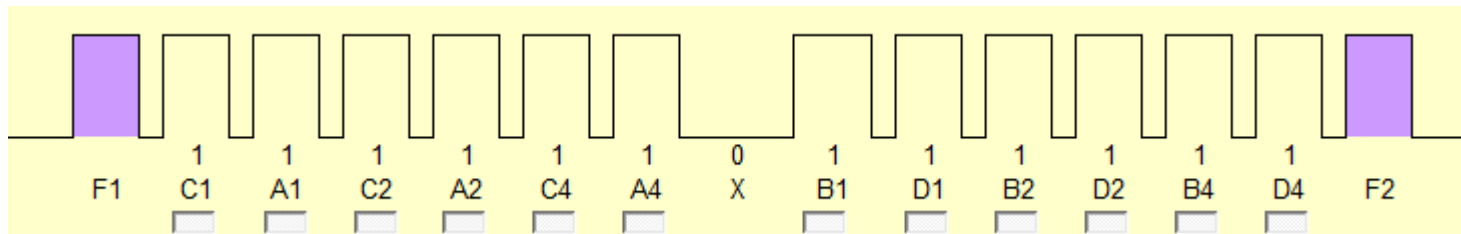



Mode S operations-- Dialogue between Mode S Interrogator and Transponder Generation Polynomial

$G(x)$ was first discovered by Kasami in 1964. It was then applied to Mode S radar by MIT Lincoln Laboratory.

<<Some Efficient Shortened Cyclic Codes for Burst-Error Correction>>

---- TADAO. KASAMI

TABLE I

| $\sigma = r - 2b$ | b | r | n | $g(x)$ |
|-------------------|-----|-----|-----|------------|
| 0 | 11 | 22 | 65 | 37774757 |
| 0 | 12 | 24 | 72 | 177772011 |
| 0 | 13 | 26 | 78 | 564625255 |
| 0 | 14 | 28 | 82 | 3000056271 |
| 1 | 9 | 19 | 121 | 2203717 |
| 1 | 10 | 21 | 127 | 12463441 |
| 1 | 11 | 23 | 111 | 60005741 |
| 1 | 12 | 25 | 131 | 321327031 |
| 2 | 7 | 16 | 200 | 207375 |
| 2 | 8 | 18 | 209 | 1274533 |
| 2 | 9 | 20 | 248 | 4076773 |
| 3 | 6 | 15 | 366 | 170787 |
| 3 | 7 | 17 | 420 | 713561 |
| 3 | 8 | 19 | 524 | 2643127 |

Dept. of Electronics
University of Osaka



Mode S operations-- Dialogue between Mode S Interrogator and Transponder II & SI Code

In order to avoid ambiguity :

⇒ for each Mode S interrogator is allocated an Interrogator Code (IC) to protect it from interference by other Mode S interrogators operating in overlapping airspace.

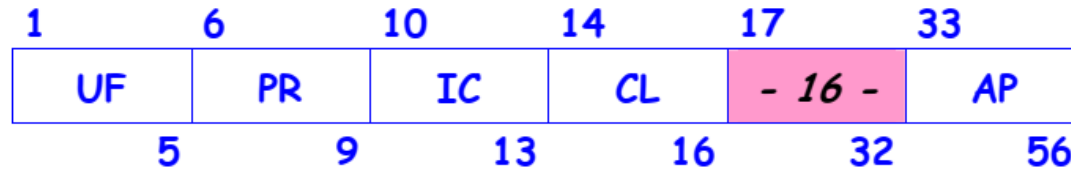

If CL = 000, IC =II.

If CL = 001 to 100 (decimal value 1 to 4), IC=last four bits of the SI code

2 types of Interrogator Code (IC) are used :

⇒ the Interrogator Identifier (II) code,0-15, 0 is used for non-selective

⇒ the Surveillance Identifier (SI) code,1-63, multisite surveillance and the limited data link functions

(It shall not be used with the multisite uplink or down link ELM protocols)



Mode S operations-- Dialogue between Mode S Interrogator and Transponder II & SI Code

- Not all transponders are capable of operating with SI code.

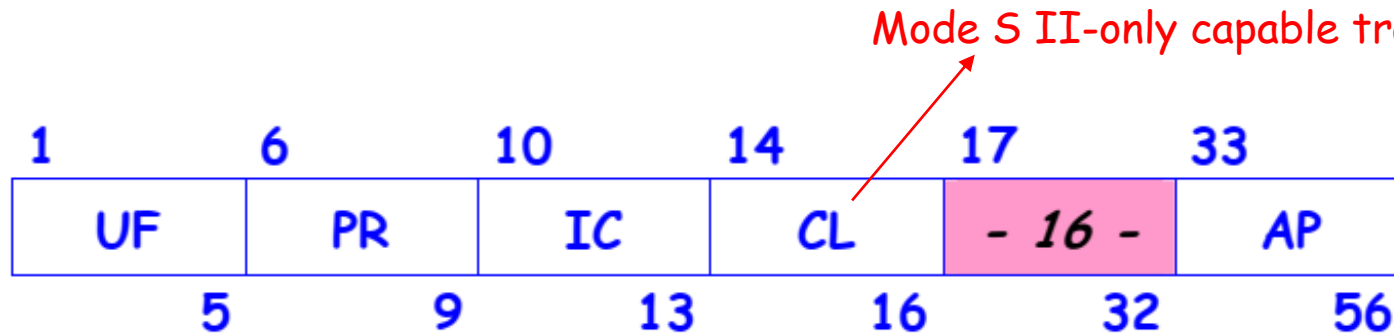

- Transponders which have not been upgraded to handle SI code, by default, consider the content of the IC field as being an II code value.
- So, if CL is not equal to zero (meaning that the IC field contains SI code), the II only capable transponders encode the parity sequence of the reply using the "matching" II code rather than the SI code contained in the interrogation.



Mode S operations-- II & SI Code

- ⇒ The interrogator operation with SI code, which will receive Mode S-only all-call replies encoded with the "matching" II code will normally reject these replies. The consequence is that Mode S II-only transponders which have not been upgraded to handle SI codes will not be detected by the interrogator operating with an SI code.
- ⇒ The Mode S II/SI capable interrogator that supports the use of II/SI code operation, if operating with an II code, must be configurable by the user to either:
 - a) not lockout Mode S transponders that do not report the SI capability in Register 10 or cannot report Register 10
 - b) use intermittent lockout for transponders that do not report the SI capability in Register 10 or cannot report Register 10
- ⇒ The Mode II/SI capable interrogator that supports the use of II/SI code operation, if operating with an SI code, must be configurable by the user to either:
 - a) acquisition the transponder on "matching" II code ;
 - b) not lockout non-SI capable transponders on the "matching" II code; or
 - c) use intermittent lockout for this "matching" II code.



Mode S operations-- II & SI Code

Allocation principle

The IC has to be unique :

- ⇒ It cannot be used in a coverage overlapping with other (non-connected) interrogators using that same II or SI code.
- ⇒ The II only interrogator can not have overlapping coverage with the interrogator with it's matching SI code.



Mode S operations-- Acquisition & Lockout Acquisition

- Mode S Acquisition: Obtain aircraft's ICAO 24bits address and approximate position information for next roll-call activity.
- Multisite acquisition: Using the Mode S-only all-call UF11. The transponder replies DF11 to this interrogation if it is not in a lockout state to that specific IC. (II=1-15,SI=1-63)

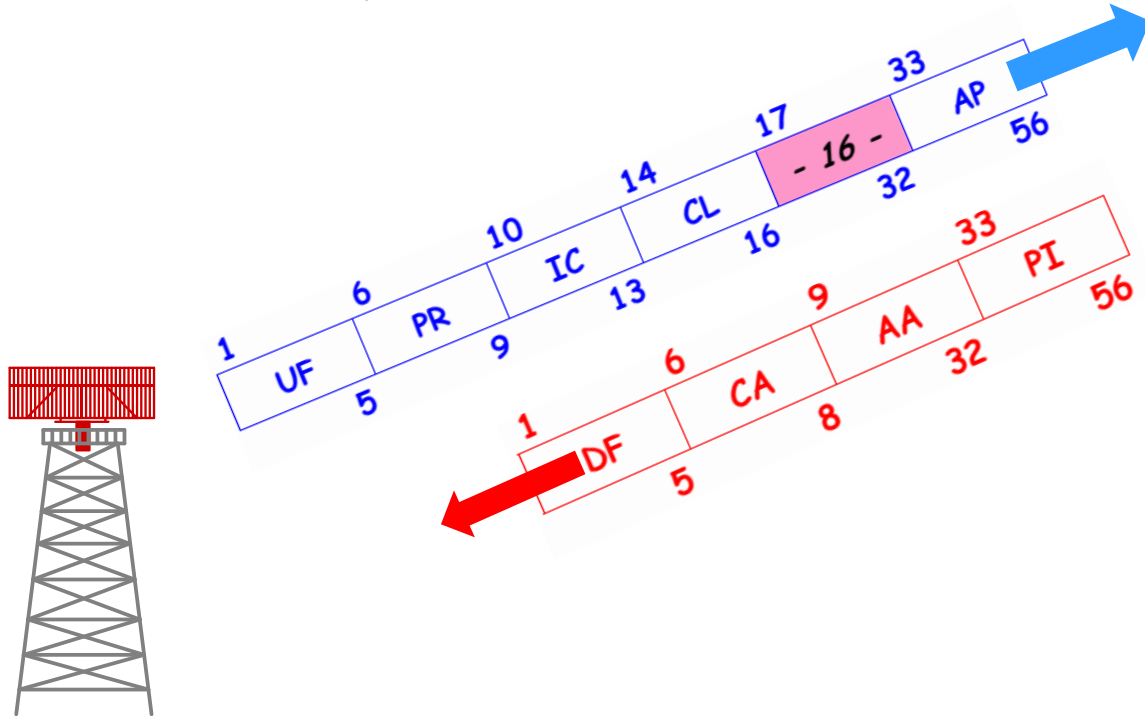



Mode S operations-- Acquisition & Lockout Lockout

- Lockout: Once acquired, the Mode S transponder should be locked out from replying to subsequent Mode S all-call interrogations from specific IC code Mode S radar in order to minimize all-call synchronous garbling.
- This lockout condition is controlled by the Mode S radar through Roll-Call interrogation. If for any reason an aircraft ceases to receive roll-call interrogations containing a lockout command for a period of 18 seconds, the lockout state will lapse so that the aircraft can be reacquired by Mode S acquisition.

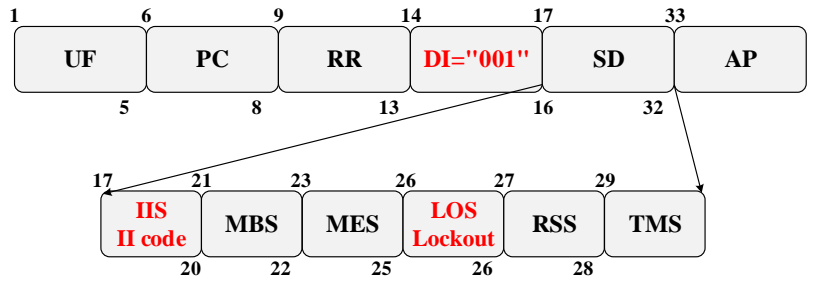

II CODE LOCK OUT, II ≠ 0

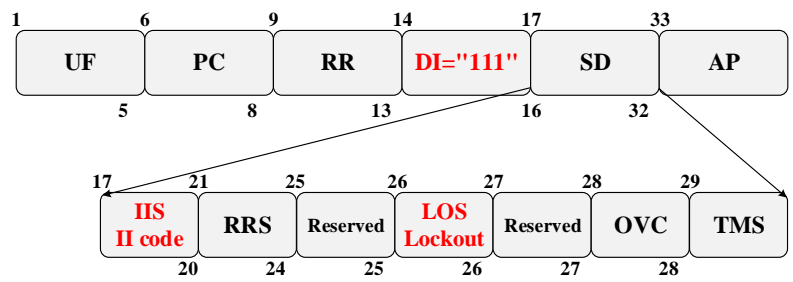

II CODE LOCK OUT, II ≠ 0

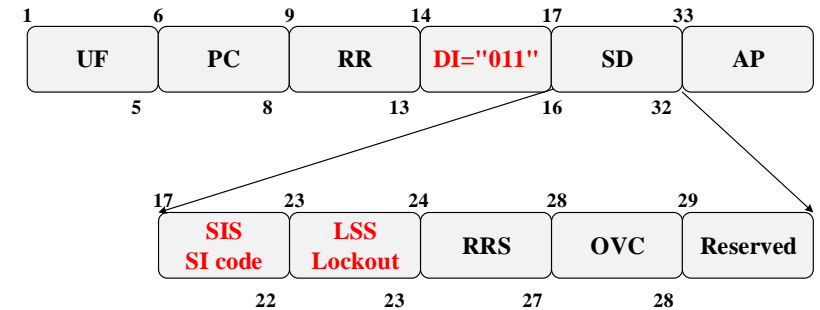

SI CODE LOCK OUT



Mode S operations—Progressive Interaction Between Interrogator and Transponder

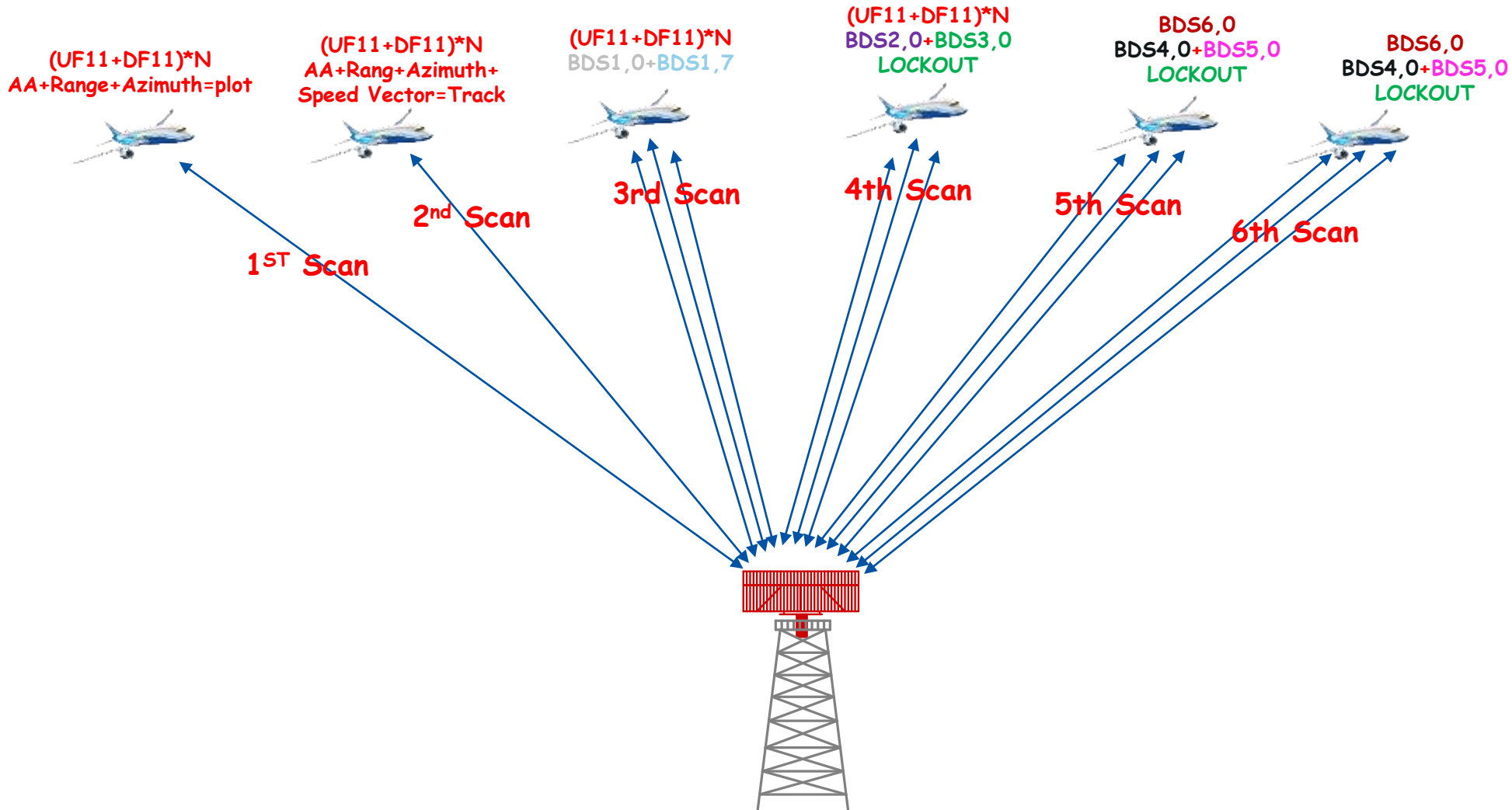



Mode S operations—Mode Interlace Pattern

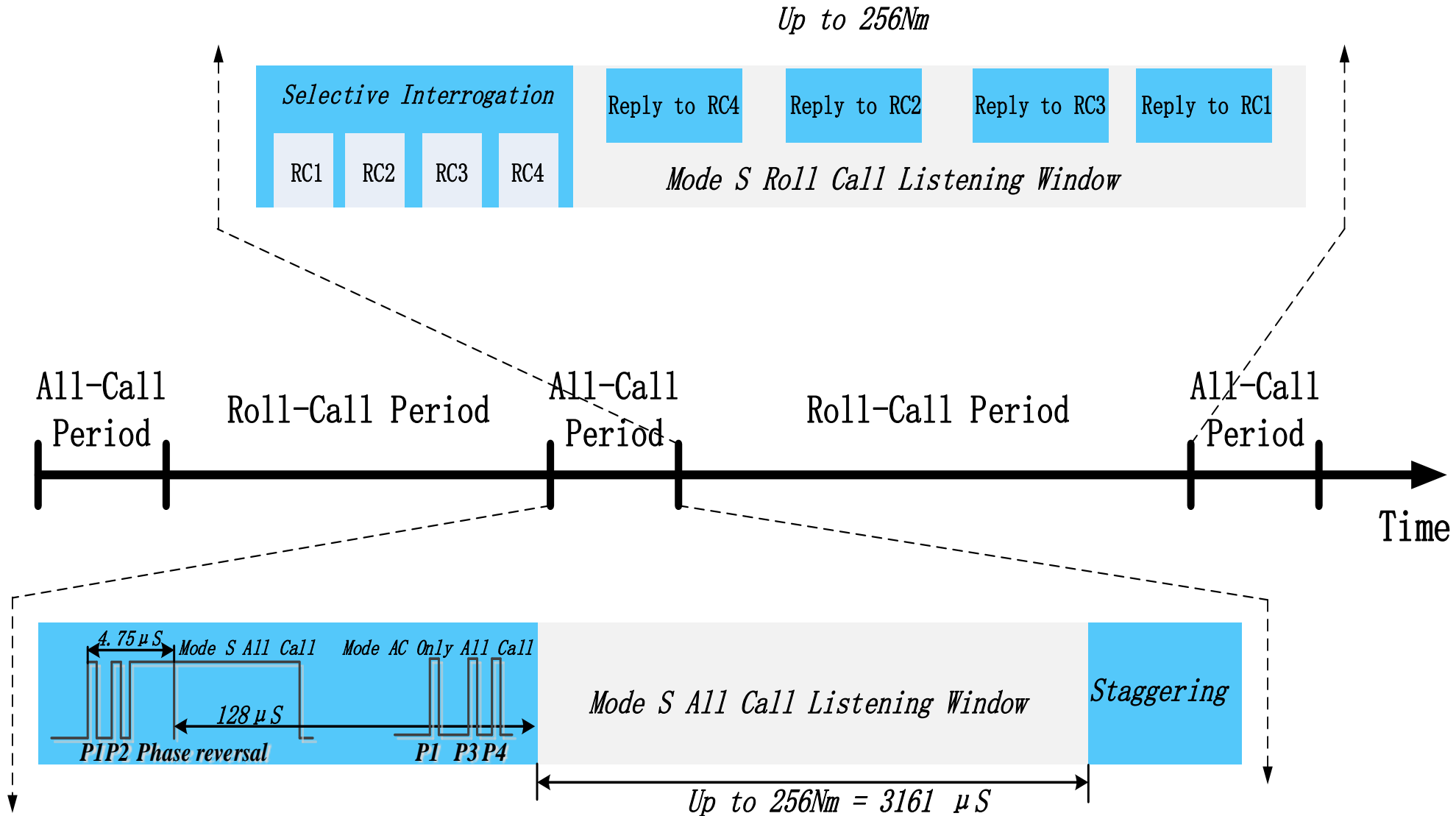



Mode S operations—Mode Interlace Pattern

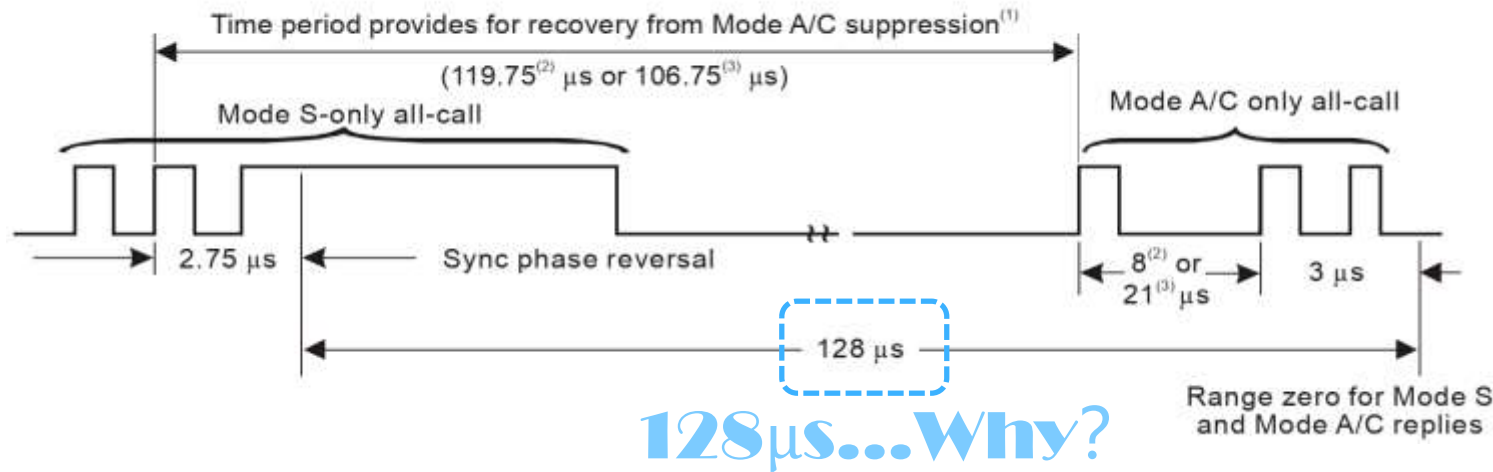

- It is desirable to provide at least 45 microseconds spacing between the interrogations to ensure that Mode A/C transponders recover from the suppression caused by the Mode S interrogation preamble. The spacing shown is the maximum possible without interfering with the receipt of zero range Mode S all-call replies.

The transponder suppression shall be for a period of 35 plus or minus 10 microseconds.

--3.1.1.7.4.2 ICAO Annex10 Volume IV 5th Edition

- If STC is to be used, the spacing of 128 microseconds must be used to provide an identical range zero point for Mode S and SSR replies.



Mode S operations—Mode Interlace Pattern Interleaving for Mode S Roll-Call

- Scheduling of Mode S roll-call interrogations and replies occurs under the following principles:
 - a) Mode S interrogations are addressed only to aircraft within the antenna beam;
 - b) channel time is allocated to each Mode S interrogation and reply based upon a prediction of aircraft range;
 - c) the ground station is able to interrogate an aircraft more than once while it remains in the beam.

-----3.2.3 ICAO Doc 9924 Appendix J, 3rd Edition



Mode S operations—Mode Interlace Pattern

Interleaving for Mode S Roll-Call

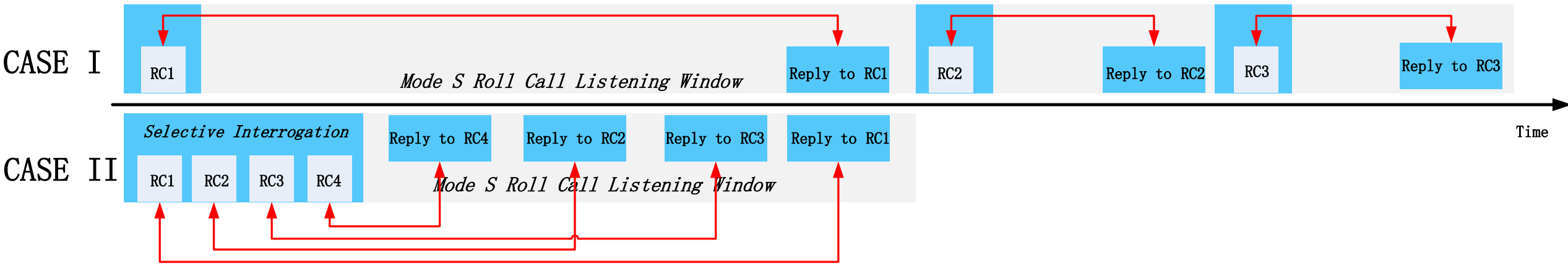

- Although the time of transmission and reception periods of any roll call- reply transaction can't be interleaved, but with the proper scheduling, the TL (listening window) of two or more roll call- reply transactions can be interleaved by scheduling the transmission and/or receive time intervals of one transaction in the wait phase of another transaction to save the restricted beam dwell time.
- The Uplink roll-call and downlink reply contain ICAO 24-bit address, So the pairing of the interrogation and reply can be completed without ambiguity.



Mode S operations– Time Constraint

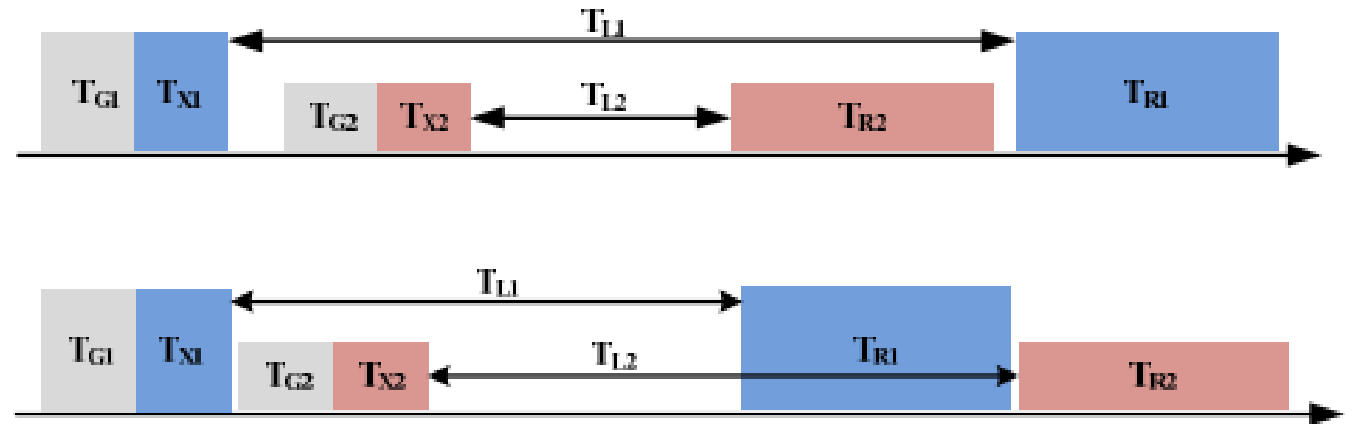
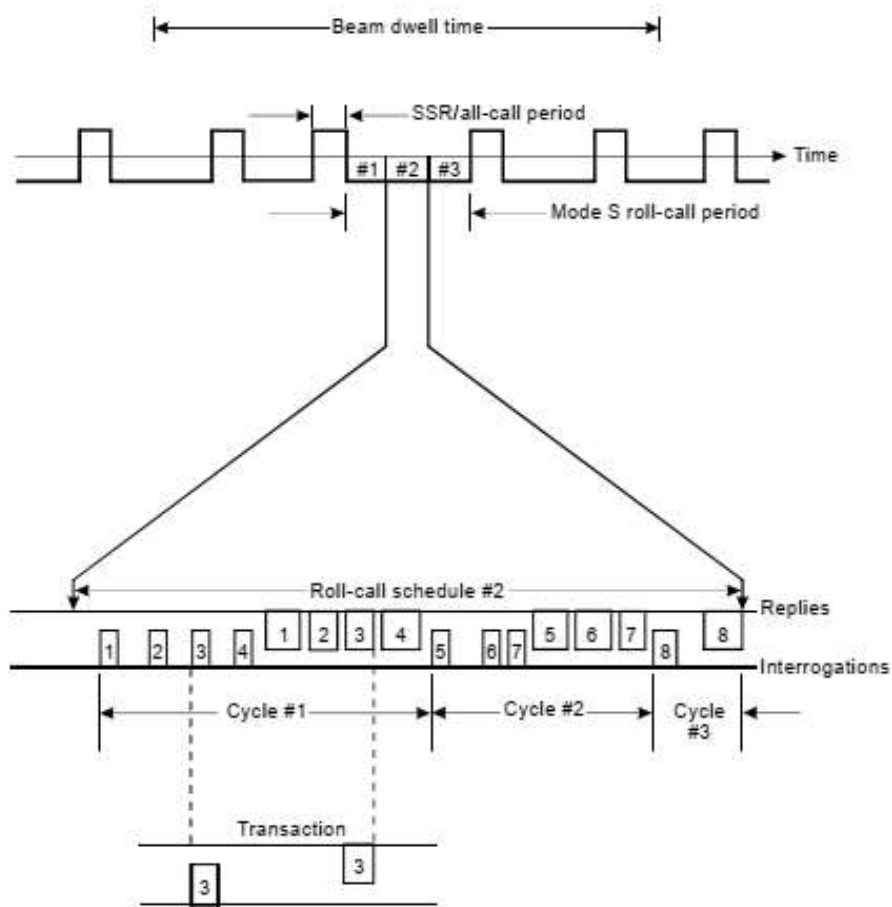



Mode S operations-- Time constraint

Scenario:
PRF = 150Hz
Beam Width = 2.4°
Rotation = 4 S
Instrument Range = 250nm

$$\begin{aligned}T_{\text{Beam-dwell Time}} &= 2.4^\circ \times 4s/360^\circ = 27ms \\N_{\text{All-call}} &= 27ms \times 150Hz \approx 4 \\T_{\text{All-Call}} &= 4 \times (3161 + 128 + 4.75) = 13.18ms \\T_{\text{Roll-Call}} &= 40 - 13.18 = 26.8ms \\RC_{\text{Max}} &= 2400 \times 26.8ms = 64 \\&64 \div 7 = 9\end{aligned}$$

For all Mode S interrogators, the transmission rate for selective interrogations shall be:
a) less than 2 400 per second averaged over a 40-millisecond interval; and
b) less than 480 into any 3-degree sector averaged over a 1-second interval.



Mode S operations-- Power constraint

- The interrogation repetition rate for the Mode A/C/S all-call, used for acquisition, shall be less than 250 per second. This rate shall also apply to the **paired Mode S-only and Mode A/C-only all-call interrogations** used for acquisition in the multisite mode.
-----3.1.2.11.1.1.1 ICAO Annex10 Volume IV, 5th Edition
- The minimum time between the beginning of successive Comm-C interrogations **shall be 50μS**.
-----3.1.2.11.1.2.2 ICAO Annex10 Volume IV, 5th Edition
- As a minimum, the transmitter shall be capable of operating at a peak duty cycle of **63.7%** over **2.4ms** length of time. It is expected that the above requirement can be repeated every 24ms.
-----Surveillance Mode S European Mode S Functional Specification
Eurocontrol



Mode S operations-- Time constraint

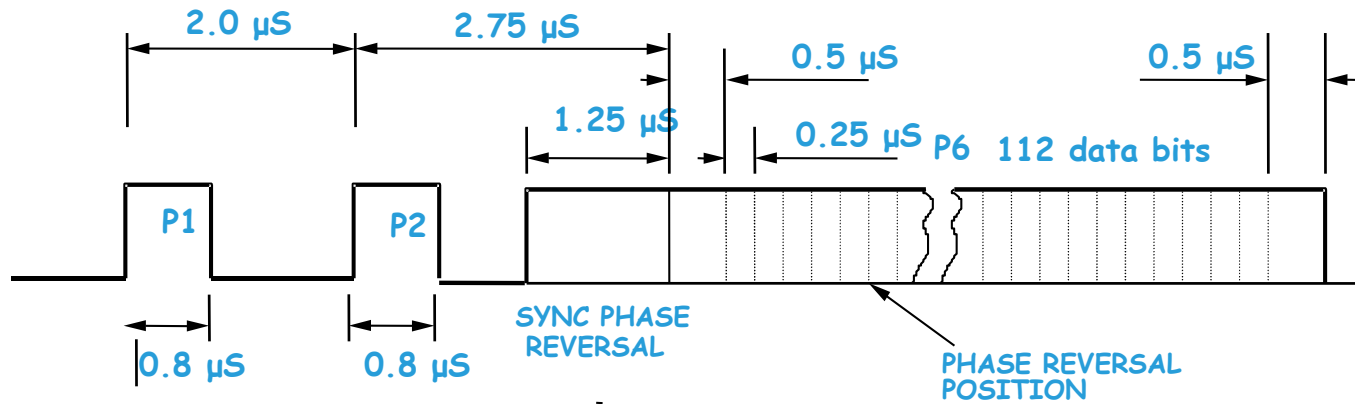

Comm-C Pulse-Time
 $= 0.8 + 0.8 + 1 + 1.25 + 112 * 0.25 = 31.85 \mu s$
 peak duty cycle
 $31.85 \mu s / 50 \mu s = 63.7\%$

Requires the capability of 48 consecutive COMM-C TRANSMISSION in 2.4 ms.

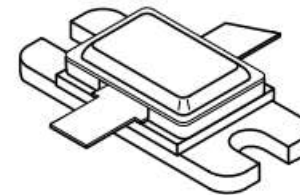
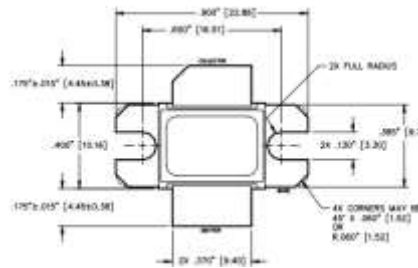

MDS60L/MDS500L:ELM Burst: 32μSec ON/ 18μSec OFF x 48, repeated at 23mSec



ELS and EHS





ELS & EHS-- Operational requirements

In Mode S ELS implementation, requirements of the aircraft and ground Mode S system

- a) Selective interrogation.
- b) Use of ICAO Aircraft Address.
- c) Automatic reporting of ACID.
- d) Report of transponder capability.
- e) Altitude reporting with a resolution of 25ft (subject to aircraft capability).
- f) Provision of flight status to indicate airborne or on-the-ground (subject to aircraft capability).
- g) Report of SI Code capability; and
- h) ACAS active resolution advisory report (when equipped with TCAS)

Mode S EHS implementation

- a) includes all the features of Mode S ELS
- b) BDS 4,0
- c) BDS 5,0
- d) BDS 6,0



ELS & EHS-- Benefits

- **Improve tracking accuracy** through the use of DAPs information (track, turn, speed and heading of the aircraft) in the track calculation.
- **Improve the accuracy of safety nets**, e.g., Short-Term Conflict Alert (STCA), through the provision of more accurate aircraft tracks, and Medium-Term Conflict Detection (MTCD), Minimum Safe Altitude Warning (MSAW), through the provision of the earlier judgment of vertical movement.
- **Allow the implementation of new safety nets** in ATM automation system for cross-checking selected aircraft vertical intention (i.e., Selected Altitude) with ATC controllers' instruction as well as verifying the barometric pressure setting applied in the aircraft with QNH setting in ATM automation system.
- **Improve situational awareness of ATC controllers** by enabling the direct access of aircraft parameters in ATM automation system, e.g., Indicated Air Speed, Mach speed, Selected Altitude, Barometric Pressure Setting, etc.
- **Progressive reduction of R/T workload per aircraft.**



ELS & EHS-- Register Introduction

Mode S Register Assignments (Partial)

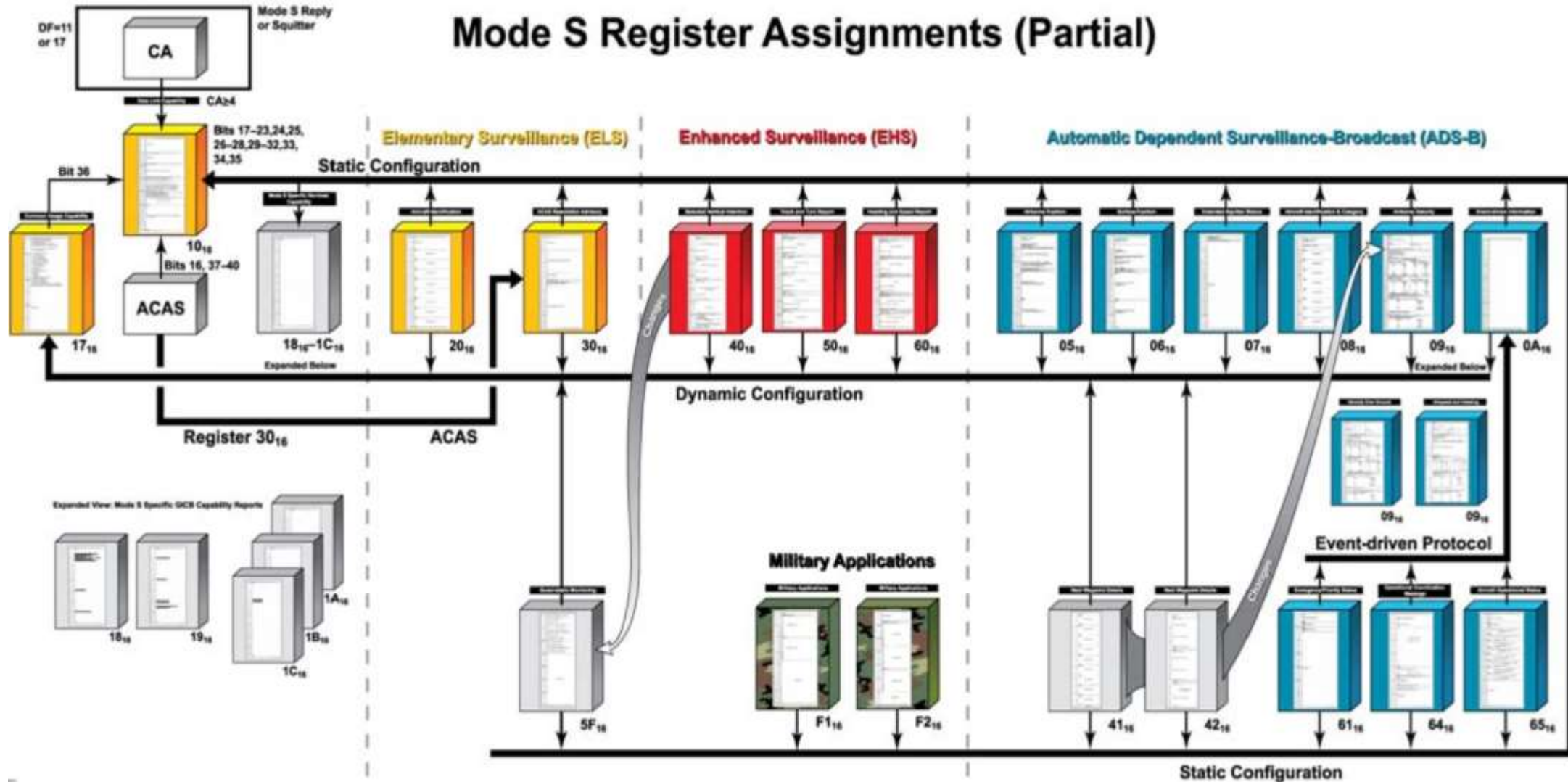



ELS & EHS-- Register Introduction

| Register | Name | Usage | |
|--------------|-------------------------------------|--|---|
| BDS code 1,0 | Datalink Capability Report | To report the data link capability of the Mode S transponder/data link installation. | |
| BDS code 1,7 | Common Usage GICB Capability Report | To indicate common usage GICB services currently supported. | |
| BDS code 2,0 | Aircraft Identification | To report aircraft identification to the ground. | |
| BDS code 3,0 | ACAS Resolution Advisory Report | To report ACAS active resolution advisory | |
| BDS code 4,0 | Selected Vertical Intention | MCP/FCU Selected Altitude | To provide information about the aircraft's current vertical intentions |
| | | FMS Selected Altitude | |
| | | Barometric Pressure Setting | |
| | | MCP/FCU Mode | |
| | | Target Altitude Source | |
| BDS code 5,0 | Track and Turn Report | Roll Angle | To provide track and turn data to the ground systems. |
| | | True Track Angle | |
| | | Ground Speed | |
| | | Track Angle Rate | |
| | | True Air Speed | |
| BDS code 6,0 | Heading and Speed Report | Magnetic Heading | To provide heading and speed data to ground systems. |
| | | Indicated Air Speed | |
| | | Mach Number | |
| | | Barometric Altitude Rate | |
| | | Inertial Vertical Velocity | |

More details in ICAO Doc 9871, 2nd Edition and ICAO APAC Mode S Daps IGD, Edition 3.0.



ELS & EHS-- Optimal register extraction GICB

Extraction: Insertion of BDS 1 and BDS 2 codes into roll-call (UF 4, 5, 20, 21) to read out aboard BDS data

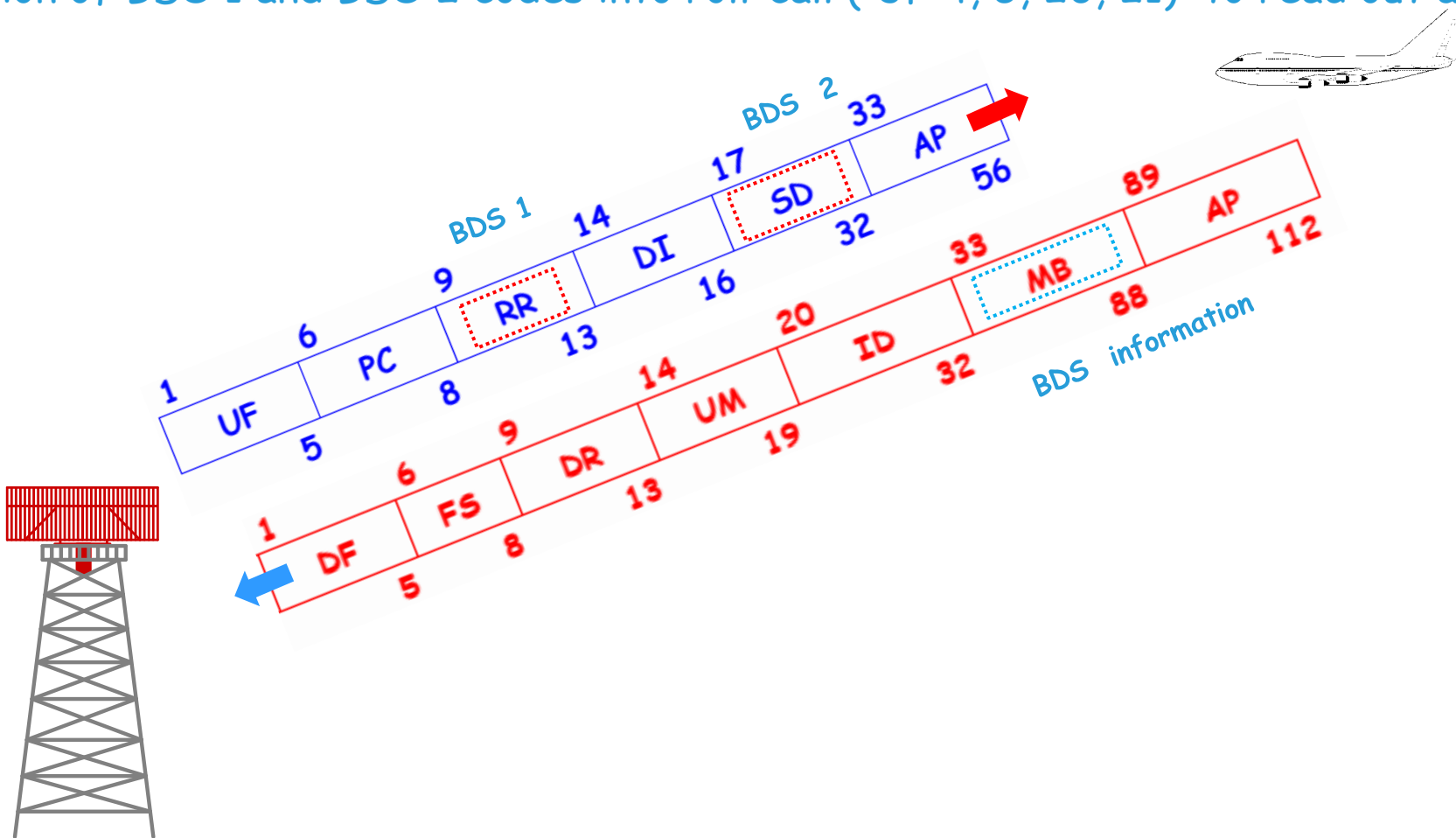



ELS & EHS-- Optimal register extraction Comm-B Broadcast

- Initiation:** To Insert DR codes 4, 5 into roll-call reply DFs 4, 5, 20, 21 and starting the B-timer (18 s).
- Extraction:** To extract the broadcast message, an interrogator shall extract BDS0,0
RR = 16 and DI ≠ to 7 or RR = 16 and DI = 7 with RRS = 0 in a next roll call interrogation.
- Interruption:** AICB activity can interrupt a Comm-B broadcast cycle. If a broadcast cycle is interrupted, the B-timer shall be reset, the interrupted broadcast message shall be retained.
- Currently, only registers of register BDS 1,0 and BDS 2,0 make use of the Comm-B Broadcast.

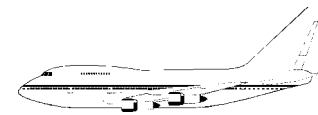
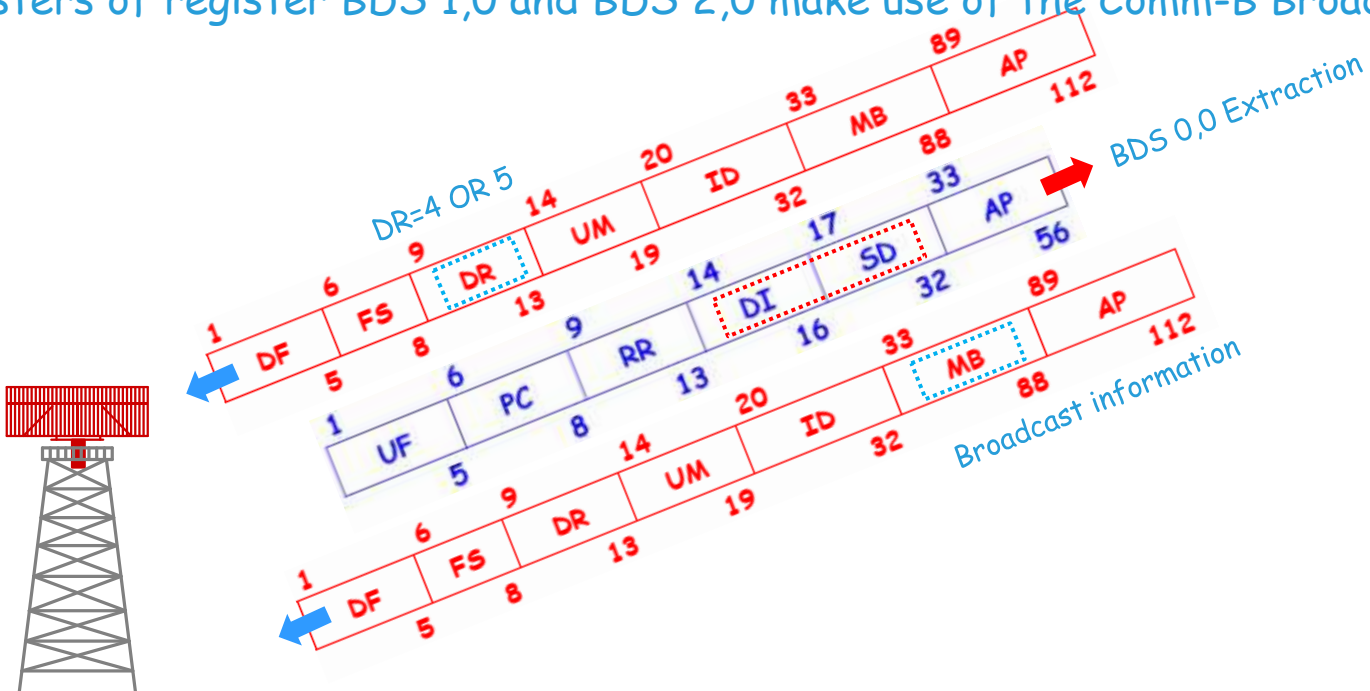



ELS & EHS-- Optimal register extraction Air-Initiated Downlink of RA Report

Initiation: To insert code 2,3,6,7 in the DR field to announce the presence of active Resolution Advisory (RA) message .

Extract: Interrogator shall transmit a request for a Comm-B message reply in a subsequent roll-call with RR and RRS for BDS 0,0.

Finish: DR=2, 3, 6 or 7 shall remain set for 18 ±1 seconds following the end of the RA unless superseded by a new ARA.

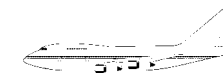
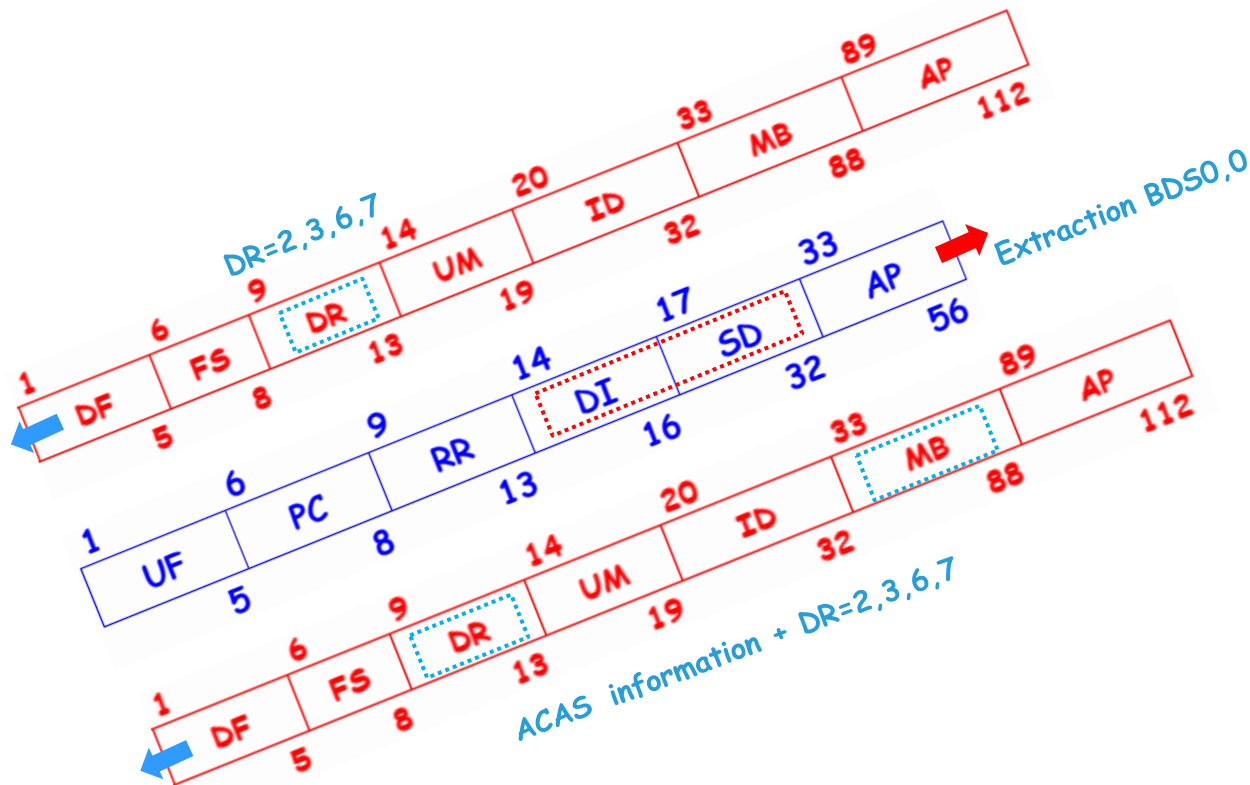
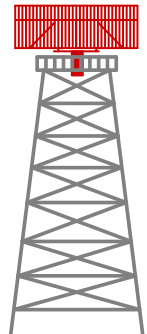



ELS & EHS-- Optimal register extraction AICB

Initiation: The transponder insert code 1 (1,3 RTCA) in the DR field to announce the presence of an AICB message .

Extract: The interrogator shall transmit a request for a Comm-B message reply in a subsequent roll-call with RR and RRS for BDS 0,0.

Finish: After a Comm-B closeout has been accomplished, the message shall be cancelled and the DR code belonging to this message immediately removed.

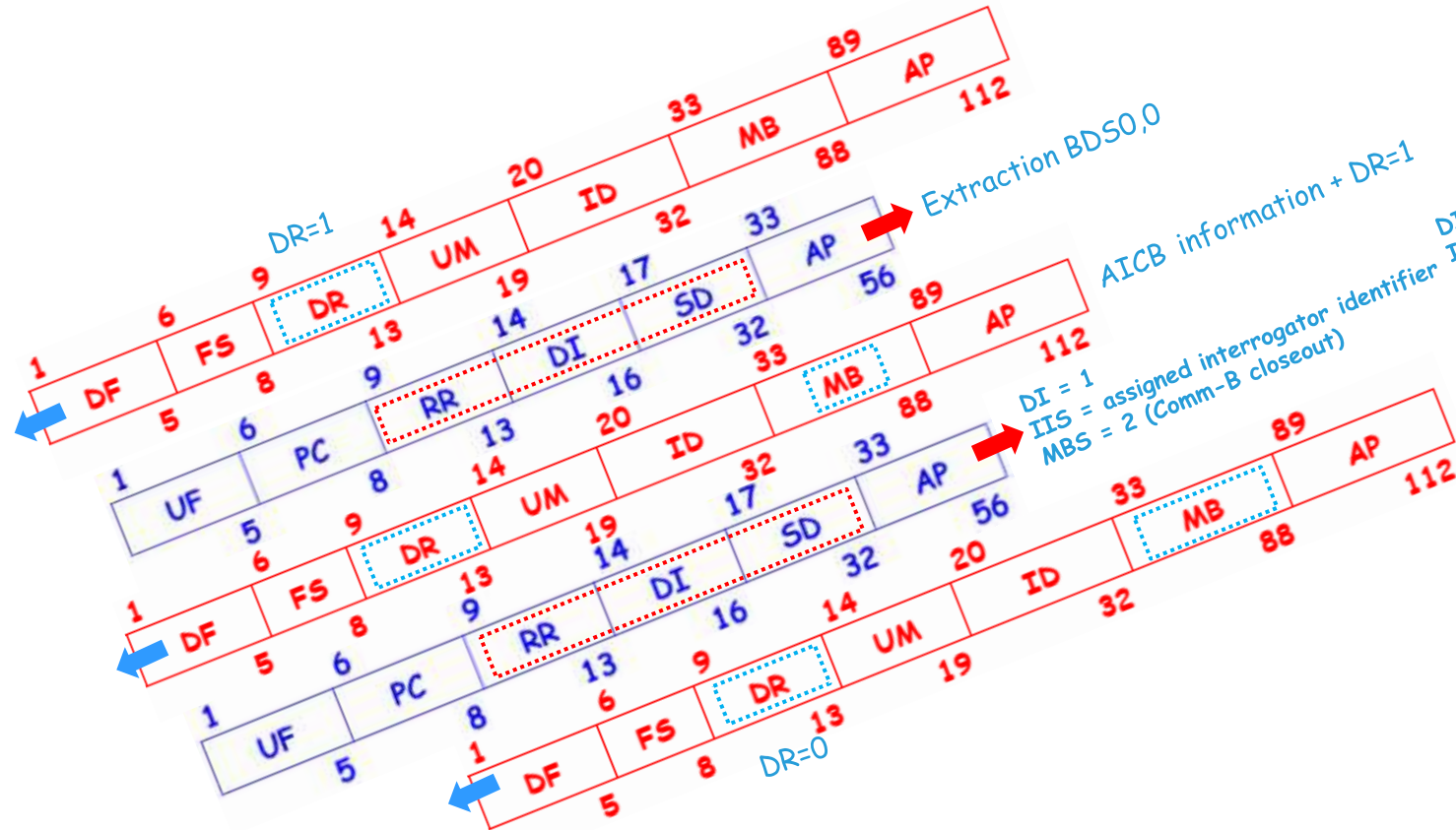
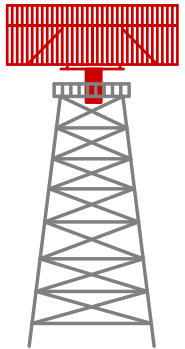

DI = 0, 1 or 7
 IIS = assigned interrogator identifier
 PC = 4 (Comm-B closeout)



ELS & EHS– Optimal register extraction

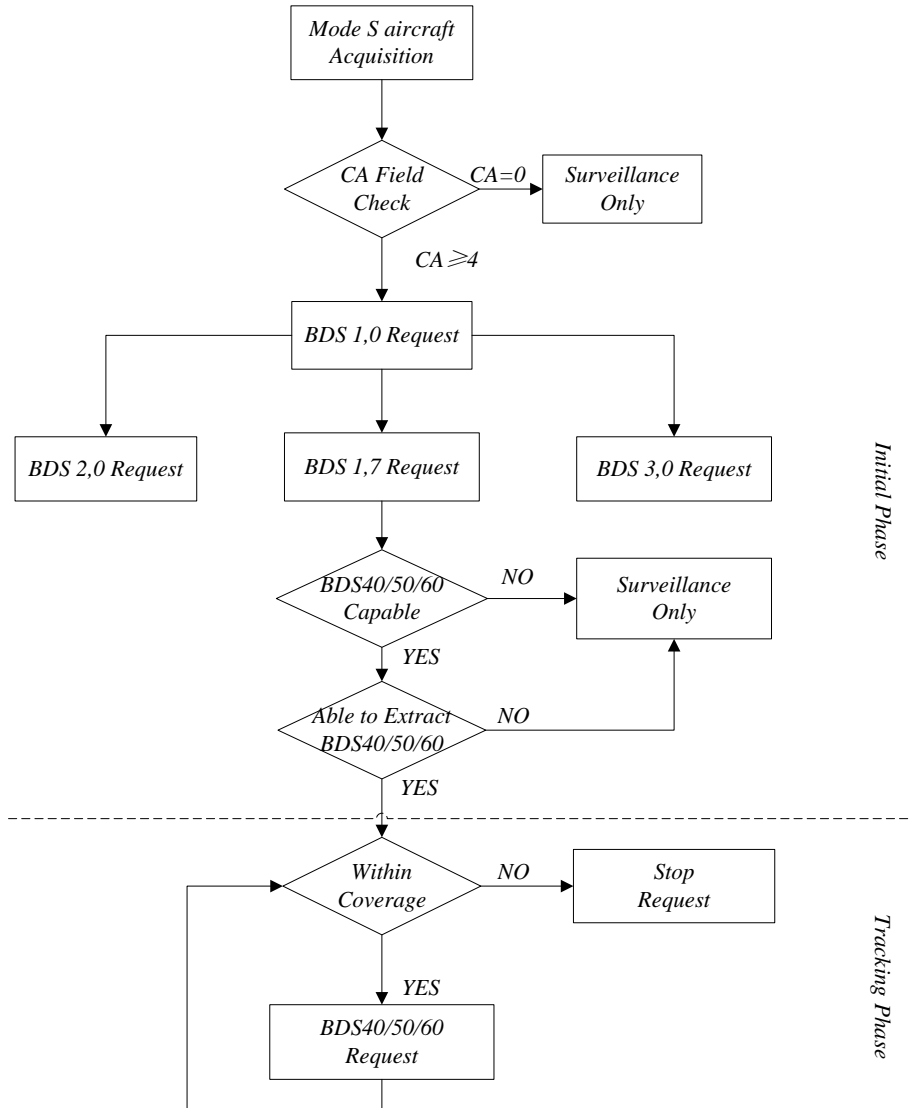

- Reg. 10₁₆, 20₁₆, 17₁₆, 30₁₆ are the static or semi-static registers and do not need to be extracted all the time.
- Any changes in the contents of the Reg. 10₁₆, 20₁₆, or 30₁₆ triggers a downlink message via the Comm B broadcast or Air-Initiated Downlink of RA Report including the updated register contents.
- The changed state might result in interruption of certain Mode S data link functions.
- A change in the value of the common-usage GICB report bit in the data link capability report (Reg. 10₁₆) would cause the application to re-extract the contents of the common-usage GICB capability report (Reg. 17₁₆).



Mode S Transponder





Mode S transponder-- Basic electrical specification

Operating at altitudes above 15000 ft, or have a maximum cruising true airspeed in excess of 175 kt (324 km/h)----Class I

Operate at altitudes not exceeding 15000 ft, and have a maximum cruising true airspeed not exceeding 175 kt (324 km/h)-----Class II

RF Peak Power:

The RF peak output power of each pulse of each reply at the terminals of the antenna shall be as follows.

a. CLASS I Equipment

Minimum RF peak power: 51.0 dBm (125 W).

Maximum RF peak power: 57.0 dBm (500 W).

b. CLASS II Equipment

Minimum RF peak power: 48.5 dBm (70W).

Maximum RF peak power: 57.0 dBm (500 W).



Mode S transponder-- Reply Capability Mode AC

Mode AC

- All Transponders The transponder shall be able to continuously generate at least 500 Mode A/C 15-pulse replies per second.
- CLASS 1 Equipment shall be capable of a peak reply rate of 1200 Mode A/C replies per 1S for a 15-pulse coded reply for a duration of 100 milliseconds
- CLASS 2 Equipment shall be capable of a peak reply rate of 1000 Mode A/C replies per 1S for a 15-pulse coded reply for a duration of 100 milliseconds



Mode S transponder-- Reply Capability Mode S

The total reply rate over each time interval, shall be the sum of the individual Mode A/C replies at an average rate of 500 per second and the Mode S reply rate over that interval.

a. Short DF Reply Rates

- (1) 50 Mode S replies in any one-second interval;
- (2) 18 Mode S replies in a 100-millisecond interval;
- (3) 8 Mode S replies in a 25-millisecond interval;
- (4) 4 Mode S replies in a 1.6-millisecond interval.

b. Long DF Reply Rates

A transponder shall be able to transmit as long replies;

- (1) at least 16 of the 50 Mode S replies in any one-second interval;
- (2) at least 6 of the 18 Mode S replies in a 100-millisecond interval;
- (3) at least 4 of the 8 Mode S replies in a 25-millisecond interval;
- (4) at least 2 of the 4 Mode S replies in a 1.6-millisecond interval.



Mode S transponder---Interrogation acceptance

II/SI Capable Transponder

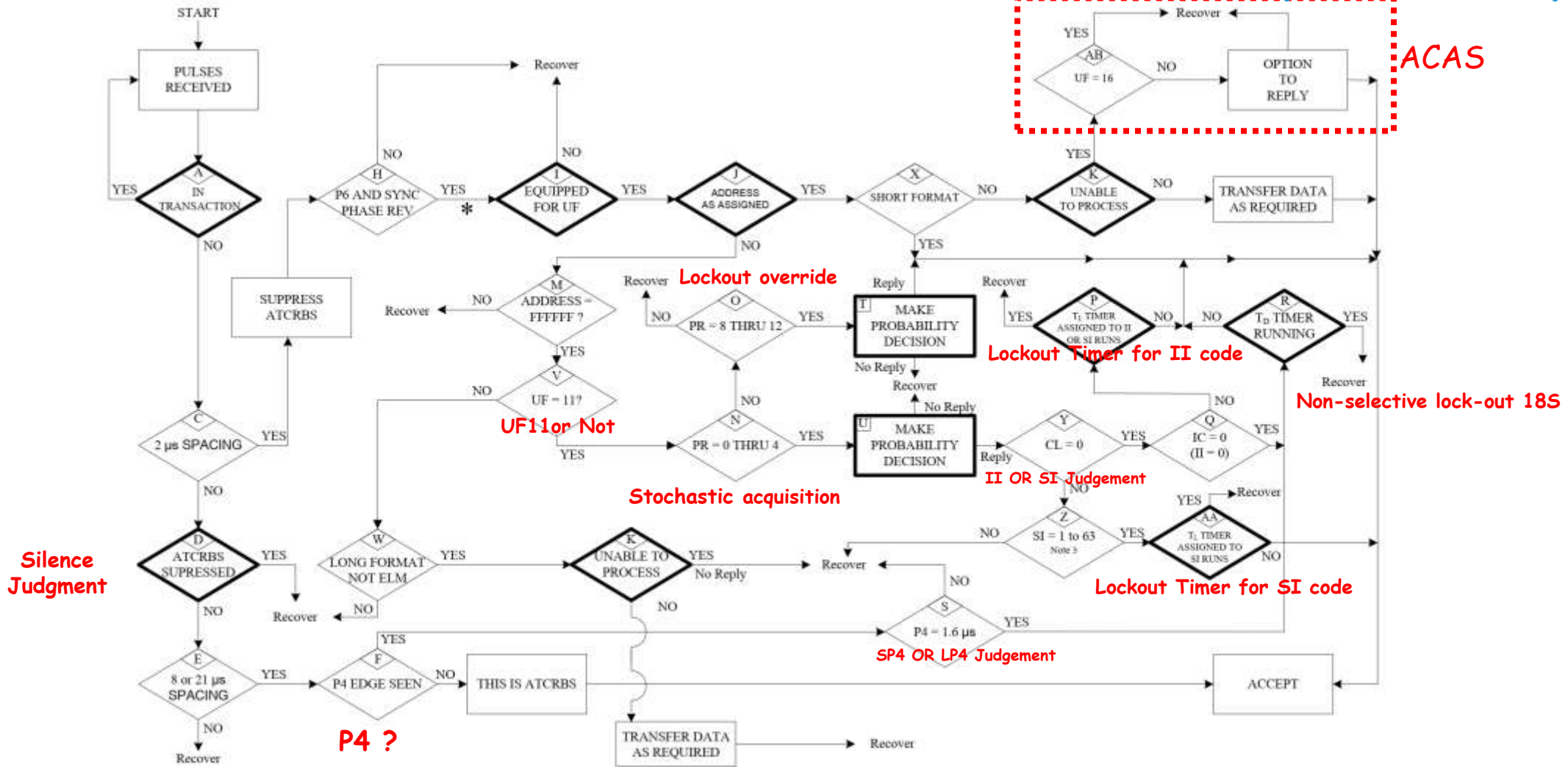



Mode S transponder---Interrogation acceptance

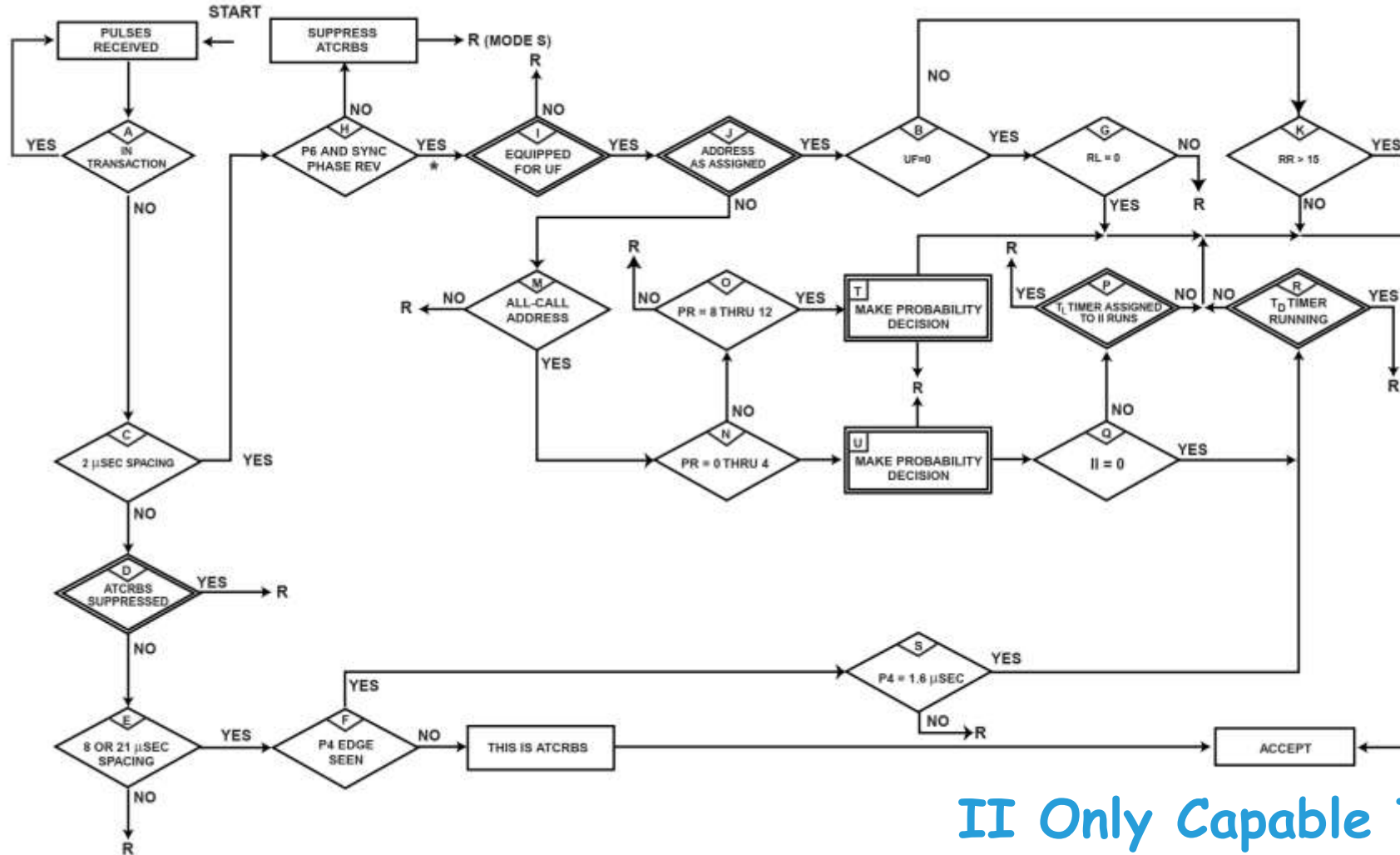

II Only Capable Transponder



Mode S transponder--- Lockout Protocol

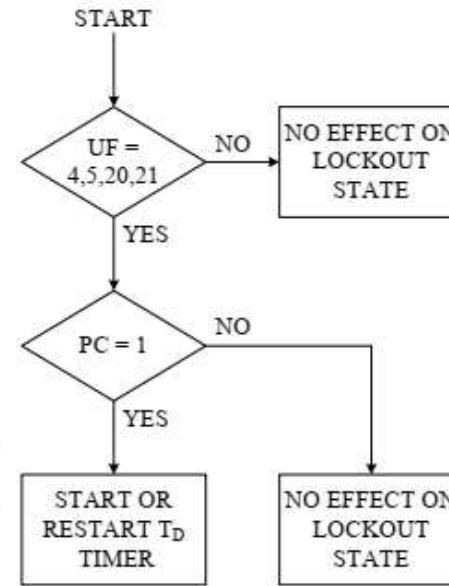
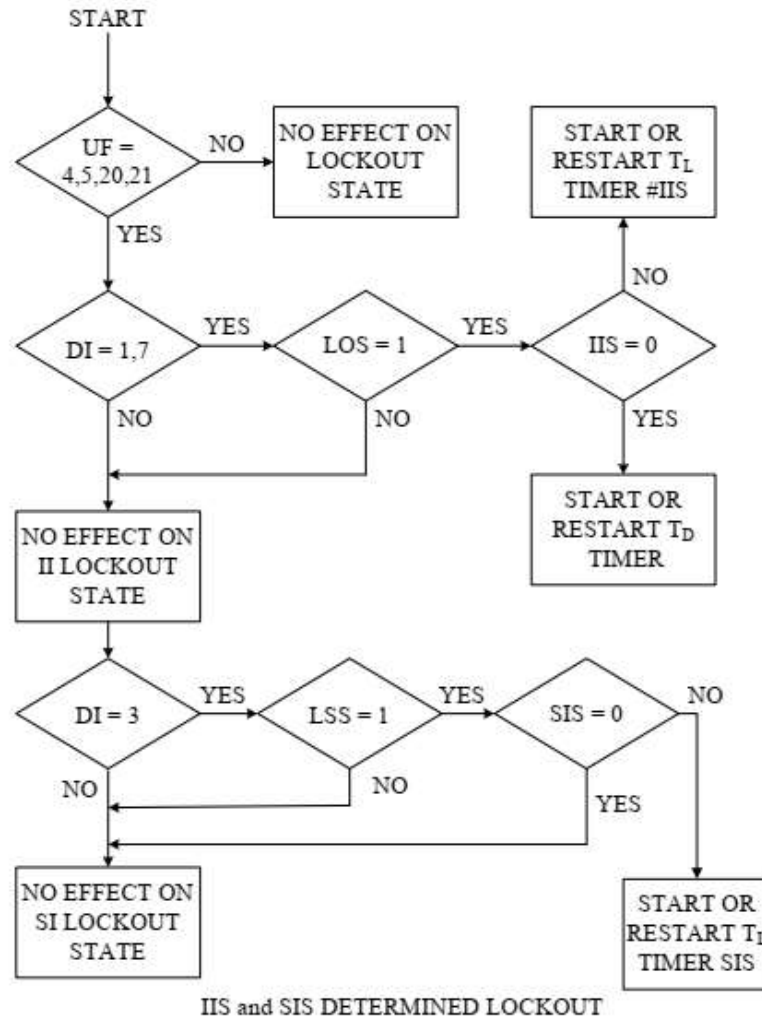

II/SI Capable transponder



Mode S transponder--- Lockout Protocol

II Only Capable transponder

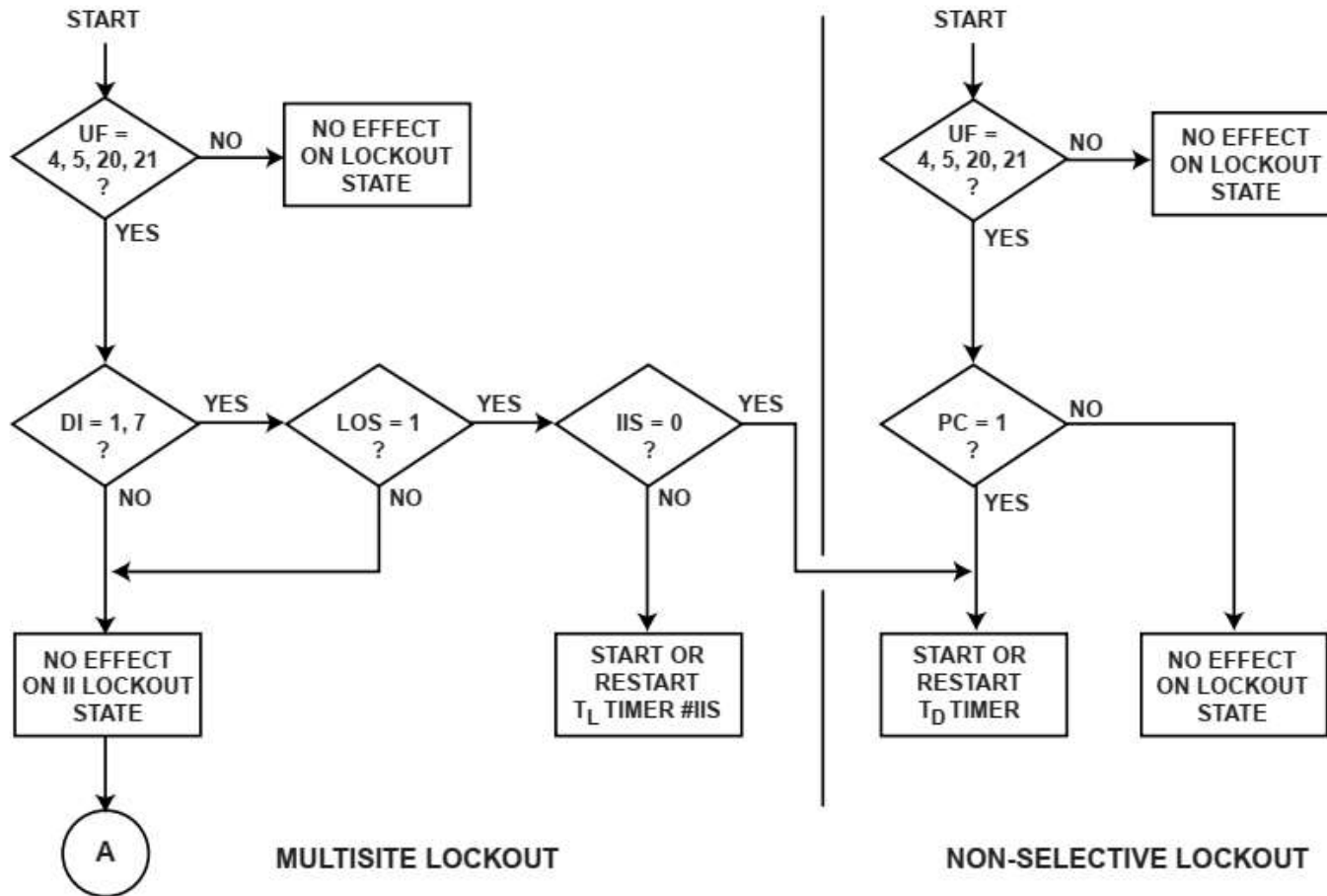



ICAO

UNITING AVIATION

NO COUNTRY LEFT BEHIND



Flight Inspection for a Mode S Radar





Flight inspection for a Mode S radar

At present, many ANSPs require *GICB*, *COMM-B* broad-related capabilities in the technical specifications when purchasing Mode S radars. Flight Inspection is recommended for the following capabilities which have not been mentioned in ICAO Doc 8071 2nd Edition:

Prior to commissioning,

- It is recommended for a verification of the *GICB*, *COMM-B* broadcast protocols in the flight inspection.
- It is recommended to perform stochastic acquisition and lockout override tests in the flight inspection.
- It is recommended to perform *II* and *SI* operation in the flight inspection.



ICAO UNITING AVIATION

NO COUNTRY LEFT BEHIND



APAC's proposed modifications to Doc. 9924





APAC's proposed modifications to Doc. 9924

Existing Doc 9924 Appendix H provided information on acquisition and lockout protocols

Improvements are made to:

- Explain II and matching SI codes.
- Provide elaboration on the II/SI code operation where the interrogator acquires both II and SI transponders, but intentionally only lock out SI transponders and not lock out II only transponders.

Existing Doc 9924 Appendix J provided information on II code assignments

Improvements are made to:

- Provide guidance on code assignment when there is a mixture of II and SI code interrogators in an environment where II only transponders still exist.
- Explain the conditions when the radar coverage can overlap safely.



ICAO

North American
Central American
and Caribbean
(NACC) Office
Mexico City

South American
(SAM) Office
Lima

ICAO
Headquarters
Montréal

Western and
Central African
(WACAF) Office
Dakar

European and
North Atlantic
(EUR/NAT) Office
Paris

Middle East
(MID) Office
Cairo

Eastern and
Southern African
(ESAF) Office
Nairobi

Asia and Pacific
(APAC) Sub-office
Beijing

Asia and Pacific
(APAC) Office
Bangkok



THANK YOU