



ICAO

**The Second Meeting of the Asia/Pacific Air Traffic Management Automation System Task Force (APAC ATMAS TF/2)**

Video Tele-Conference, 14 - 16 September 2021

---

**Agenda Item 4:** ATM Automation System Implementation by States

4.4 Integration and Interoperability with External Systems

**SOLUTION OF FLIGHT PLAN ASSOCIATION CONSISTENCY BETWEEN TOWER ATM AUTOMATION SYSTEM AND ATM AUTOMATION SYSTEM**

(Present by China)

**SUMMARY**

This paper presents the solution of flight plan association consistency between the tower ATM automation system and the ATM automation system.

**1. BACKGROUND**

1.1. CAAC has redefined the concept of integrated towers as the Tower ATM automation system which is an independent system suitable for the tower control operation. Its advantages are gradually reflected in Chinese civil aviation.

1.2. The Tower automation system is characterized by high integration, strong safety, convenient operation and simple maintenance. The system is in close connection with the ATM automation system. Data interaction and sharing shall be realized to ensure the data consistency between two systems. For controllers, the flight plan association consistency between two systems is one of the basic requirements.

**2. DISCUSSION**

2.1. The Tower automation system and the ATM automation system usually respectively process surveillance data and AFTN messages. Life cycle of flight plan differs in the two systems (as shown in Figure 1 & Figure 2 below), and processing logic differs in different kinds of messages. Due to the complex operation scenarios, it is easy to appear various problems caused by association inconsistencies.

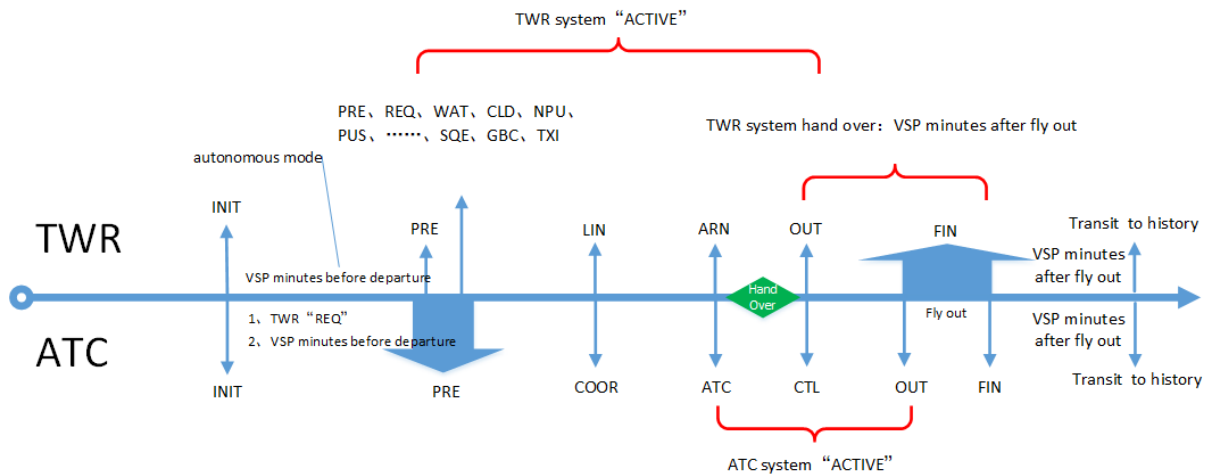

Figure 1. Life Cycle Difference of Departure Flight Plan Between Tower and ATM

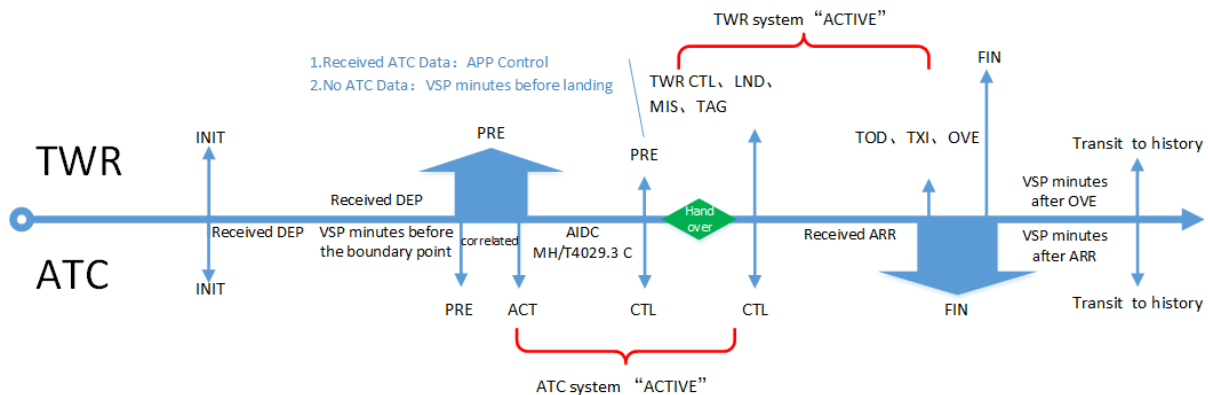

Figure 2. Life Cycle Difference of Arrival Flight Plan between Tower and ATM

**2.2. problems caused by CNL**

2.2.1. For some reason, the airline may merge two flight segments with the same callsign of a connecting flight into one flight. In this case, the airline sends FPL message for the first segment, and then sends CNL message to cancel the previous plan, and sends a new FPL message in the end.

2.2.2. For an outbound flight, two systems create plans by receiving the first FPL. After releasing clearance, the flight plan enters into Active State and couples with the plan in the tower automation system. In the meantime, the plan keeps Pre-active State in the ATM automation system. At this time, if the CNL message is received, the tower ATM automation system will discard this message due to active state. The ATM automation system will handle the message normally and terminate the plan, and create a new flight plan by the second FPL message. After taking off, the ATM automation system will couple the radar track with the new plan. Obviously, inconsistent flight plan association will result in the handover failure.

**2.3. problems caused by CPL**

2.3.1. When receiving a CPL message in which the flight alternate landing airport is local airport, the Tower ATM automation system usually creates flight plan directly by ignoring route

information. On the contrary, the ATM automation system will check the route. If the check fails, the flight plan will not be created, and the CPL message will be put into the error message queue.

2.3.2. Once the track of this flight enters the control area, in the ATM automation system it cannot be correlated without flight plan. When the track is in tower area, it can be correlated automatically in the Tower ATM automation system. The correlation state is different in the two systems.

#### 2.4. **problems caused by DLA**

2.4.1. When the flight delayed for a long time and the DLA message is not received, the flight plan state is inconsistent in the two systems because the life cycle parameter configuration for the abnormal flight plan is different.

2.4.2. Since the flight has been released, the delay would not affect the plan state in the Tower ATM automation system. But in the ATM automation system, the flight plan may be terminated due to the delay expired the configuration of VSP time.

2.4.3. There is the flight plan in the Tower ATM automation system so the trajectory can be normally correlated. But in the ATM automation system, the trajectory cannot be correlated and only displayed as simple signage, because there is no flight plan after the plane takes off.

2.4.4. It can be seen from the above that the difference in life cycle definition and message processing logic is easily to cause inconsistencies correlation of the flight plan, and result in a safety risk.

### 3. **SOLUTIONS**

#### 3.1. **Unified management of flight plans**

3.1.1. Since the flight plan consistency between the two systems is a prerequisite to ensure the correlation consistency, we recommend that the Tower ATM automation system synchronize the flight plan with the ATM automation system. The best solution is that the flight plan of tower gets from the ATM automation system.

3.1.2. Take Chengdu terminal, Tianfu tower and Shuangliu tower as an example. In order to ensure the robustness of the Tower ATM automation system, the system is designed with two modes:

a) Cooperative mode and autonomous mode. When the link with the ATM automation system is normal and the ATM automation system works normally, the tower automation system works in "cooperative mode". In this mode, the flight plan is created and updated by the ATM automation system. And the tower automation system does not process AFTN messages, the plan updates by following the changes in the ATM automation system.

b) When the ATM automation system fails or the link between the systems breaks, the tower automation system runs in "autonomous mode". Then the tower automation system autonomously processes the AFTN messages, creates and updates plans by the AFTN messages.

3.1.3. When the tower is running in cooperative mode, it is recommended to follow the principles of 'who controls who modifies' and 'who cares who modifies', in order to ensure the priority and consistency of the flight plan data.

**Agenda Item 4.4**

14 – 16/09/21

**3.2. trajectories exchanged between systems**

3.2.1. In order to maintain the correlation consistency between the systems, the ATM automation system and the Tower ATM automation system need to exchange the system track. The ATM automation system sends the airborne track to the Tower automation system. At the same time, the Tower ATM automation system sends the ground track to the ATM automation system. It is recommended to use ASTERIX Cat062 as the system track data exchange protocol.

3.2.2. The track relation between the ATM automation system and the Tower ATM automation system is established by checking ACID, SSR code, position and altitude. If all the conditions above are met, the correspondence of track in the two systems establishes.

3.2.3. It is recommended to use system track overlap area to ensure the track reliability and to reduce the occupation of system resources(as shown in Figure 3 below).

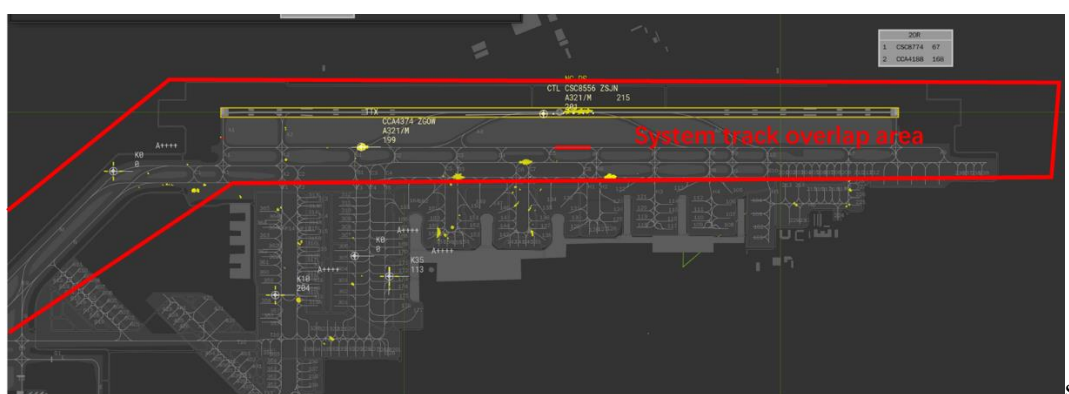

Figure 3.SystemTrackOverlap Area

**3.3. flight correlation consistency between systems**

3.3.1. For arrival flight, it is suggested that the ATM automation system correlation results should be given higher priority. The Tower ATM automation system verifies the correlation consistency by using the trajectory correspondence with the ATM automation system. It checks the flight callsign, destination&departure aerodrome information in the corresponding flight plan to make sure the correlation of the arrival flight be consistent in the two systems.

3.3.2. For departure flight, it is suggested that the Tower ATM automation system correlation results should be given higher priority. The ATM automation system verifies the correlation consistency by using the trajectory correspondence with the ATM automation system. It checks the flight callsign, destination& departure aerodrome information in the corresponding flight plan to make sure the correlation of the arrival flight be consistent in the two systems.

**4. ACTION BY THE MEETING**

4.1. The meeting is invited to:

- a) Note the information contained in this paper, and
- b) Discuss any relevant matters as appropriate.

-----