



NOTE DE TRAVAIL

GROUPE D'EXPERTS SUR LES MARCHANDISES DANGEREUSES (DGP)

VINGT-SEPTIÈME RÉUNION

Montréal, 16 – 20 septembre 2019

- Point 2 : Gestion des risques de sécurité propres au transport aérien et détection des anomalies**
2.2 : Élaboration, s'il y a lieu, de propositions d'amendement des *Instructions techniques pour la sécurité du transport aérien des marchandises dangereuses* (Doc 9284) à introduire dans l'édition de 2021-2022
- Point 3 : Gestion des risques de sécurité présentés par le transport aérien des piles au lithium**
3.4 : Examen des mesures visant à atténuer les risques présentés par le transport ou l'utilisation des piles au lithium par les passagers, les membres d'équipage et l'exploitant (*fiche de tâches DGP.003.02*)
- Point 10 : Questions diverses**

**PRÉSERVATION D'ORGANES HUMAINS DESTINÉS À LA TRANSPLANTATION
LORS DU TRANSPORT PAR VOIE AÉRIENNE**

(Note présentée par E. Gillett)

RÉSUMÉ

La présente note propose que l'équipement contenant des marchandises dangereuses pour la préservation d'organes humains destinés à la transplantation soit exempté du champ d'application des dispositions des Instructions techniques.

Le Groupe DGP est invité à examiner la proposition d'amendement de la Partie 1, § 1.1.5 des Instructions techniques qui figure en appendice à la présente note de travail.

1. INTRODUCTION

1.1 Standard heart preservation before transplantation consists of cold ischemic storage of the heart. Clinical studies have shown that the morbidity and mortality risks increase with an extension of the time over four hours to which the organ has an inadequate blood supply (allograft ischemic time). For each additional hour the mortality risk increases by 25 per cent within the first year. This time constraint is costly and results in severe logistical problems, leading to a loss of transplantable organs¹.

* Seuls le résumé et l'appendice sont traduits.

¹ [A Randomized Controlled Trial Comparing Non-ischemic to Ischemic Preservation in Adult Cardiac Transplantation \(NIHP\)](#)

1.2 Equipment for the ex-vivo preservation of hearts has been developed. An example is the XVIVO Heart Box System (see Appendix A). This device has a form factor corresponding to the cooling boxes used for organ transport today and keeps the heart perfused with a temperature and pH-controlled solution. It is understood that the equipment must be monitored during use by trained personnel and there is therefore no requirement at this time for such equipment to be carried as cargo or checked baggage.

1.3 The XVIVO Heart Box System is powered by Nickel-metal hydride batteries which are not subject to the Technical Instructions when contained within the equipment through Special Provision A199. However, similar equipment could conceivably be powered by lithium ion or lithium metal batteries. It also contains approximately 70 g of UN 3159 — **Refrigerant gas R134** (which could be deemed not subject to the Technical Instructions through Special Provision A26) and a small cylinder containing 0.4 L of a gas mixture of 95% O₂ and 5% CO₂ at 200 Bar. Although a single cylinder would be sufficient for many applications, it is conceivable that a spare bottle could be required depending on the predicted total duration of transport. Part 2;6.3.2.3.7 of the Technical Instructions establishes that organs intended for use in transplantation are not subject to those Instructions.

1.4 Air transport provides opportunities to reduce transport time, greatly expand the potential donor pool of organs that would be viable at the time of implantation and make organs available to patients with the greatest need and/or those presenting the highest likelihood of organ adoption.

1.5 Part 1;1.1.5.1 a) establishes that the Technical Instructions do not apply to dangerous goods carried by an aircraft where the dangerous goods are to provide, during flight, medical aid to a patient. However, an organ for transplant is not a patient and so the need to urgently transport human organs by air within ex-vivo preservation systems containing dangerous goods is not provided for.

1.6 The nature of dangerous goods likely to be contained within equipment designed for the ex-vivo preservation of organs for transplantation, and the need for provisions to allow their carriage and operation on board aircraft is considered analogous with the existing provisions for dangerous goods to provide medical aid for a patient. Accordingly, paragraph 2.1 proposes to supplement these existing provisions, and modify to require that lithium cells or batteries meet the applicable provisions of Part 2;9.3 (including those used for medical aid for a patient).

2. ACTION BY THE DGP

2.1 The DGP is invited to consider the amendment Part 1;1.1.5 of the Technical Instructions as shown in the appendix to this working paper.

APPENDICE A

PROPOSITION D'AMENDEMENT DES INSTRUCTIONS TECHNIQUES, PARTIE 1

Partie 1

GÉNÉRALITÉS

Chapitre 1

PORTÉE ET CHAMP D'APPLICATION

(...)

1.1 CHAMP D'APPLICATION GÉNÉRAL

(...)

1.1.5 Exemptions générales

1.1.5.1 Sauf pour la section 4.2 de la Partie 7, les dispositions des présentes Instructions ne s'appliquent pas aux marchandises dangereuses transportées par un aéronef s'il s'agit :

- a) d'administrer des soins médicaux à un patient ou de préserver des organes humains destinés à la transplantation, en cours de vol, lorsque ces marchandises :
 - 1) ont été placées à bord avec l'approbation de l'exploitant ; ou
 - 2) font partie de l'équipement permanent de l'aéronef lorsqu'il a été adapté à un usage spécialisé ;si les conditions suivantes sont remplies :
 - 1) les bouteilles de gaz ont été fabriquées expressément pour contenir et transporter ce gaz précis ;
 - 2) l'équipement contenant des accumulateurs remplis d'électrolyte est maintenu en position verticale et, lorsque c'est nécessaire, arrimé dans cette position pour empêcher un déversement de l'électrolyte ;
 - 3) les piles ou les batteries au lithium métal ou au lithium ionique sont conformes aux dispositions de la Partie 2, § 9.3. Chaque batterie au lithium de rechange doit être protégée afin de prévenir des courts-circuits lorsqu'elle n'est pas utilisée.

Note.— Pour les marchandises dangereuses que les passagers sont autorisés à transporter pour soins médicaux, voir le § 1.1.2 de la Partie 8.

(...)

APPENDIX B

AIR TRANSPORT OF XVIVO HEART BOX SYSTEM

Content

Purpose.....	2
General intended use.....	2
System description.....	2
Load securing in aircraft or in ground transport	2
Power need.....	3
Internal systems to address	3
Standards.....	4
Technical specifications XVIVO Heart Box.....	5
Emission standards.....	6
Immunity standards.....	6
Contact person XVIVO Heart Box	9

Purpose

This document describes the general function of the XVIVO Heart Box System and identifies possible dangerous goods areas. The intention is to give enough information to set out a way forward in the classification of the system from a regulation dangerous goods perspective.

The system will eventually be used first in Europe and later in North America. Usage of the system will start in mid 2019.

General intended use

The system is intended to transport human hearts between donor and recipient hospitals. The system will enable a controlled environment for the organ during the transport. The organ will reside inside the box, cooled to an appropriate temperature, and supplied with all necessary needs to keep the organ status as it was when received from the donor. The transport time can be several hours without interference from the operator. The box is kept under surveillance during the whole transport chain.

System description



Picture 1 XVIVO Heart Box System

In an aircraft the system will be transported as in Picture 1 in the aircraft cabin secured according to the operating company's directions. I.e. The Box is closed and the device is running during the flight. Overall dimensions are 740 x 420 x 420 mm.

Load securing in aircraft or in ground transport

Two securing straps can be placed on each handle. An additional strap is provided to secure the lid. No additional load can be put on top of the XVIVO Heart Box. The XVIVO Heart Box can only be positioned as in Picture 1. i.e. bottom down.

Power need

Power is either taken from mains in the aircraft or the device is running on its internal batteries.

Internal systems to address

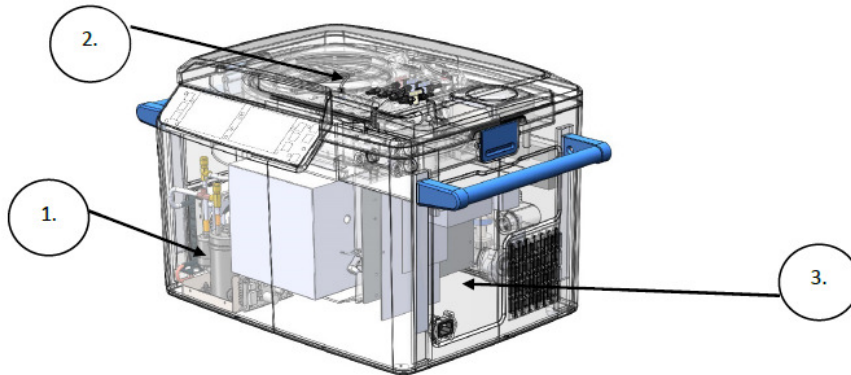

Picture 2 Front

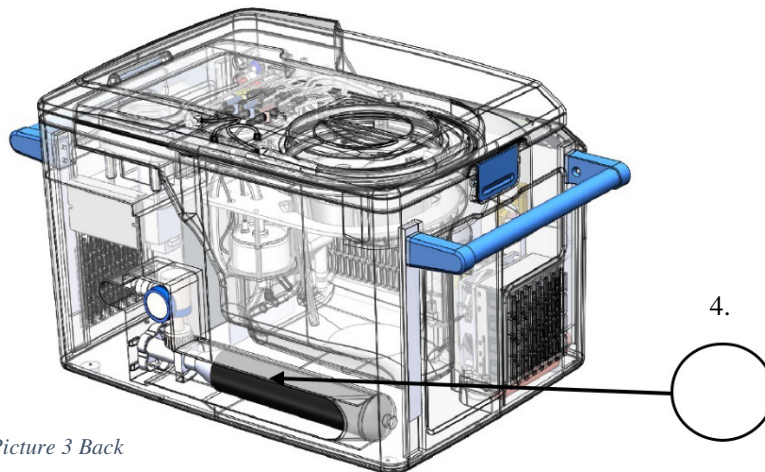

Picture 3 Back

See Picture 2. and 3. above:

1. Cooling system – a “std” compressor driven refrigerant system containing approximately 50 – 70 g of R134a refrigerant.

2. Organ reservoir – a sterile compartment/reservoir containing 3 L of a specific fluid and a human heart connected to a controlled flow path.
3. Battery pack – 24V system, NiMh batteries. Approximately 16 Ah.
4. Gas Cylinder – a 0.4L (approximately 380 x 51 mm) small gas cylinder (“Lecture bottle”) containing a gas mix of 95% O₂ and 5%CO₂ at 200Bar. DGR designation is UN 3156. The pressure is reduced in the regulator in the XVIVO Heart Box to 4.5 Bar. Internally the pressure is further reduced to ambient pressure.

Although the gas content do last for most transports it is a possibility that the operator may bring a spare bottle onboard the flight depending on the predicted total duration of the transport.



Picture 4 Currently used gas container.

Standards

Applicable standard for Medical Devices are utilized. E.g. EN60601-1-xx as a main contributor.

Else are, both the COUNCIL DIRECTIVE 93/42/EEC of 14 June 1993 and the more recent REGULATION (EU) 2017/745 OF THE EUROPEAN PARLIAMENT AND OF THE COUNCIL of 5 April 2017 are applicable. Eventually the US CFR-regulations will be applicable as well.

Technical specifications XVIVO Heart Box

Power	XHB 230 V 50 Hz/60 Hz	
Mains voltage	120/230 VAC -15% + 10%	
Power consumption	Max 3A	
Over-voltage	Category II	
Protection class	II	
Earth leakage current	Not applicable	
Fuse protection		
Main fuses	2xT6.3 AH 250 V	
Classification		
Safety classification according to	SS-EN 60601-1 (IEC 60601-1)	
Electromagnetic compatibility	SS-EN 60601-1-2 (IEC 60601-1-2) Home healthcare environment	
Encapsulation class (evaluation unit with connected disposable kit and mounted lid)	IP33	
Dimensions and weight		
Width	730 mm	
Depth	420 mm	
Height (highest operating position)	420 mm	
Weight (dry weight, without disposable kit)	25 kg	
Environment		
Ambient temperature during operation	min/max: 8/40°C	
Maximum altitude	4000 m	
Other	Specification	Measurement accuracy
Pump	0-1 l/min	± 5%, min. 0.05 l/min
Temperature measurement, all channels	0-45°C	± 0.5°C
PID arterial temperature regulation	8°C	± 0.5°C
Pressure measurement, perfusion solution	-10 mmHg to 300 mmHg	± 2 mmHg
PID perfusion solution pressure regulation	15 mmHg to 30 mmHg	± 3 mmHg

Noise level alarm/maximum noise level	69.3 dB(A)	-
Maximum permitted connected gas pressure, Carbogen (95% O ₂ /5% CO ₂)	4.5 bar Supplied from gas bottle with regulator	-
Gas flow Carbogen (95% O /5% CO)	100 ml/min	± 2 %
Technical service life	2	2
	8 years	

Emission standards

Emission test	Compliance	Electromagnetic environment - Guidance
Conducted and radiated RF emissions CISPR 11	Group 1, Class B	The emitted disturbances from the XVIVO heart box are compliant with the current regulation and is not likely to cause interference with other equipment.
Harmonic distortion IEC 61000-3-2	Class A	The emitted disturbances from the XVIVO heart box are compliant with the current regulation and is not likely to cause interference with other equipment
Voltage fluctuations and flicker IEC 61000-3-2	Complies	The emitted disturbances from the XVIVO heart box are compliant with the current regulation and is not likely to cause interference with other equipment
RF emission EUROCAE ED-14G	Category M	The emitted disturbances from the XVIVO heart box are compliant with the current regulation and is not likely to cause interference with other equipment

Immunity standards

Immunity test	EN/IEC 60601-1-2 test level	Compliance level	Electromagnetic environment - Guidance
Electrostatic discharge IEC 61000-4-2	± 8 kV contact ± 2 kV, ± 4 kV, ± 8 kV, ± 15 kV air	± 8 kV contact ± 2 kV, ± 4 kV, ± 8 kV, ± 15 kV air	The XVIVO heart box will function within specification in its intended environment.
Radiated RF EM fields IEC 61000-4-3	10V/m	10 V/m	The XVIVO heart box will function within specification

Immunity test EN/IEC	60601-1-2 test level	Compliance level	Electromagnetic environment - Guidance
			in its intended environment.
Proximity fields from RF Wireless communications equipment IEC 61000-4-3	9 to 28V/m according to IEC 60601-1-2, table 9	9 to 28V/m according to IEC 60601-1-2, table 9	The XVIVO heart box will function within specification in its intended environment.
RATED power frequency magnetic fields IEC 61000-4-8	30 A/m, 50Hz	30 A/m, 50Hz	The XVIVO heart box will function within specification in its intended environment.
Electrical fast transients /bursts IEC 61000-4-4	± 2 kV 100 kHz repetition frequency	± 2 kV 100 kHz repetition frequency	The XVIVO heart box will function within specification in its intended environment.
Surges Line-to-line IEC 61000-4-5	± 0,5 kV, ± 1 kV	± 0,5 kV, ± 1 kV	The XVIVO heart box will function within specification in its intended environment.
Surges Line-to-ground IEC 61000-4-5	± 0,5 kV, ± 1 kV, ± 2 kV	± 0,5 kV, ± 1 kV, ± 2 kV	The XVIVO heart box will function within specification in its intended environment.
Conducted disturbances induced by RF fields IEC 61000-4-6	3 V 0,15 MHz – 80 MHz 6 V in ISM and amateur radio bands between 0,15 MHz and 80 MHz 80 % AM at 1 kHz	3 V 0,15 MHz – 80 MHz 6 V in ISM and amateur radio bands between 0,15 MHz and 80 MHz 80 % AM at 1 kHz	The XVIVO heart box will function within specification in its intended environment.
Voltage dips IEC 61000-4-11	100% drop for 0.5 cycles 100% dip for 1 cycle 30% dip for 25/30 cycles	100% drop for 0.5 cycles 100% dip for 1 cycle 30% dip for 25/30 cycles	The XVIVO heart box will use internal power source when mains fail

Immunity test	EN/IEC 60601-1-2 test level	Compliance level	Electromagnetic environment - Guidance
Voltage interruptions IEC 61000-4-11	100% drop for 5 seconds	100% drop for 5 seconds	The XVIVO heart box will use internal power source when mains fail

Contact person XVIVO Heart Box
Per Frid

Sr. Project Manager

XVIVO Perfusion AB

Propellervägen 16

SE-224 78 Lund Sweden

Visitors: Propellervägen 16 SE-224 78 Lund Sweden

Email: per.frid@xvivoperfusion.com

Phone: +46 761 750 552

— FIN —