

UNIVERSITY of SOUTH CAROLINA

Department of Electrical Engineering

Air-Ground Channel Characterization

David W. Matolak

ICAO

August 2015



UNIVERSITY OF
SOUTH CAROLINA

Outline

- Introduction & Motivation
- Channel Characterization Basics & Significance
- AG Channel Measurements
- AG Channel Modeling
- Example Results
- Summary

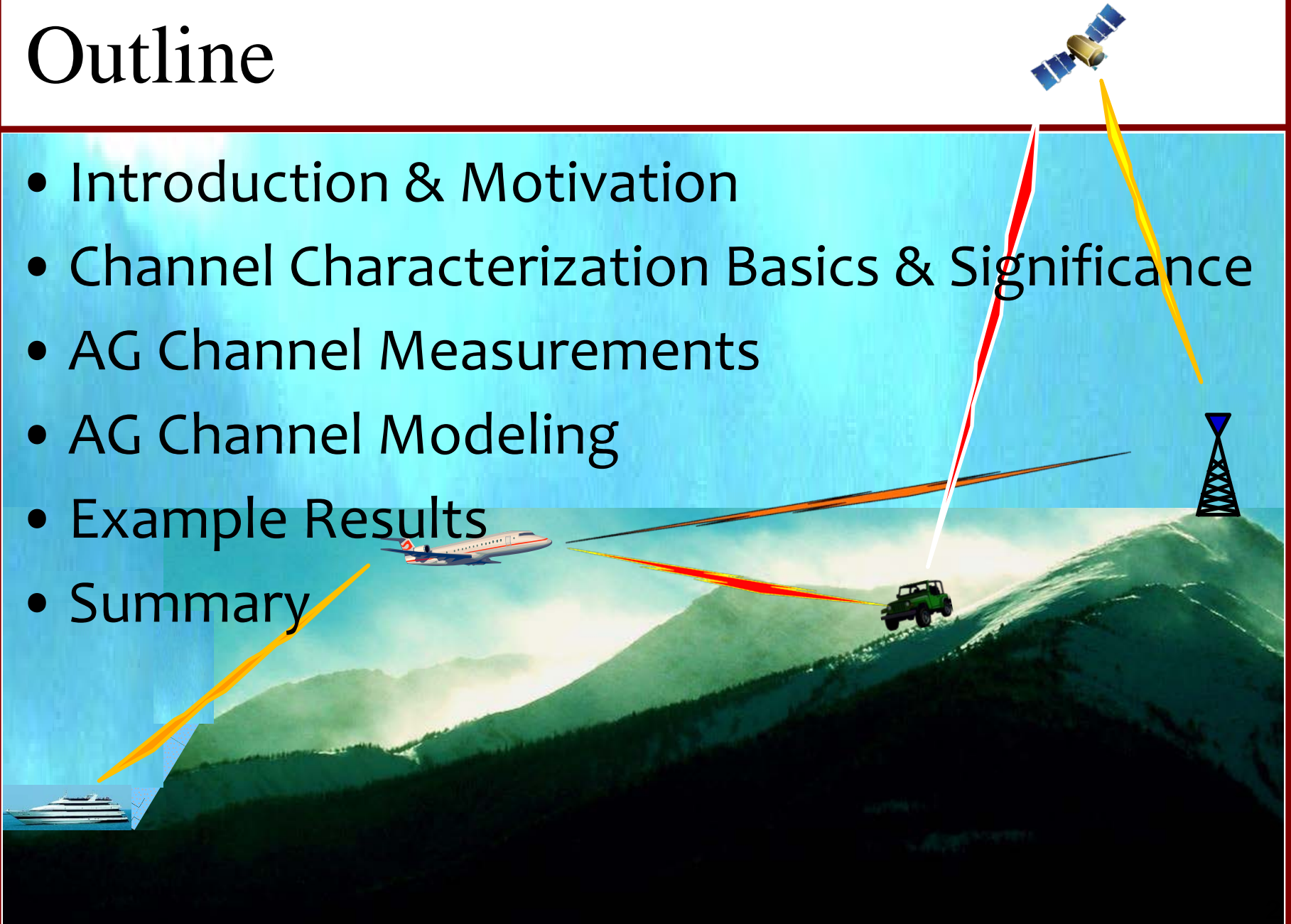

Introduction & Motivation

- Since safety & reliability paramount, UAS **CNPC** systems being specified to meet rigorous performance requirements
- NASA project (UAS in the NAS) exploring & validating technologies for reliable CNPC
 - **U. South Carolina** working w/NASA on PHY/MAC
 - **Air-ground (AG) channel**
 - Radio mod/demod
 - Networking

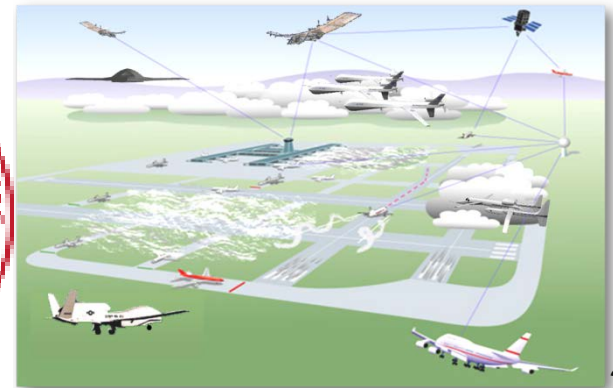

Introduction & Motivation (2)

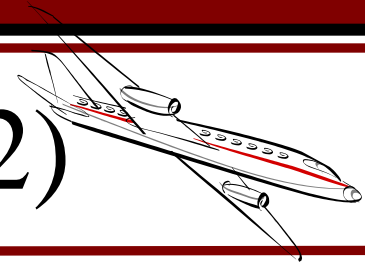

- There exist NO comprehensive, validated, *wideband* models for time-varying AG channel
- Existing measurements
 - Sparse, & for different frequency bands in widely *different* environments
 - *Not parameterized* as function of
 - Elevation \angle
 - Ground site (GS) antenna height
 - GS local environment
 - Do *not* include airframe *shadowing*

Introduction & Motivation (3)

- “Classical” AG channel
 - ~En-route, with **continuous LOS**
 - **Narrowband** signals (only path loss required)
 - GS in **open, cleared** areas, with**out** obstructions
- Modern AG channel (e.g., UAS) will **NOT** always satisfy these conditions!



University of South Carolina

Introduction & Motivation (4)



- Other organizations **studying the AG channel**
 - German Aerospace Center
 - NICT (Japan)
 - Nanyang Tech. Univ. (Singapore), Czech Tech. Univ.
 - IMST GmbH (Germany), Canadian Research Centre
 - Also past/future



- BYU
- Boeing
- ITT
- UPM (Spain)
- L3 Communications
- Virginia Tech
- USAF
- Lockheed-Martin

Channel Characterization

- Characterization means
- Accurate, **quantitative** description of channel
 - $h(\tau, t)$ or $H(f, t)$
- Translating this description into simpler functions, features, **models**
 - For use in evaluation of **signaling**
 - “Classical” AG channel characterized only by path loss

Channel Characterization Importance

- If you don't know your channel, system performance will be **sub**optimal, possibly very poor, with
 - Irreducible channel error rate, precluding reliable message transfer (e.g., **blurry** video!)
 - Severely limited data carrying capacity
- ... could require costly remediation

Channel Char. Importance (2)

- AG channel can **strongly** affect performance

Channel Effect on Signaling (“101”)

- Delay Spread (multipath) \Rightarrow Dispersion \sim distortion

– Requires compensation (equalization, multicarrier, diversity...)

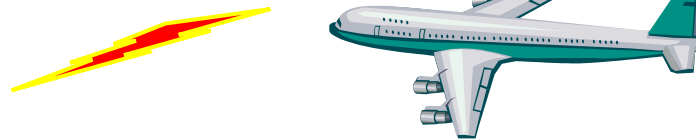

- Doppler \Rightarrow Time Variation

– Requires compensation (carrier tracking, inter-carrier interference mitigation,...)

If channel not quantified, signal design suboptimal

AG Literature Review Summary

- Some research begun in early 1960s (VHF)
- Common assumptions
 - Isolated GS in open area
 - Tall tower
 - Narrowband signals
 - Latency requirement moderate (voice)

⇒ simple channel models sufficient

Environment	Since...	# Papers (~2012)
Vehicle-to-Vehicle	2005	77
Cellular	1980	>500
Air-Ground	1960	27

Measured RMS Delay Spreads

Channel Type	Avg Delay Spread σ_τ (μs)	Max Delay Spread σ_τ (μs)	~Min Coherence Bandwidth (kHz)	Comments
<i>Airport</i>	0.5-1	2.5	80	Miami, Cleveland, JFK airports
<i>Surface</i>	0.65	1.8	111	Munich airport
<i>Air-Ground</i>	0.07	—	—	Aero telemetry w/narrow beamwidth GS antenna, open desert, 2 GHz
	3.8	7.2	27.7	VHF in Duluth, MN, Aspen, CO
	1.4	3	67	L-band, Aspen, SIMULATED only
	3	15	13	VHF, analytical + measured
	0.1	0.55	200	2 GHz, college campus
	—	0.5	400	C-band, over ocean, directional antenna
	—	0.4	500	C-band, near mountains
<i>Satellite</i>	1.2	4.5	44.4	L-band, 15-70 degree elevation angle

Delay spreads (& coherence bandwidths) vary by more than an order of magnitude

Key Channel Parameters

- Path loss (attenuation)
 - $L(d) \cong A + 10n\log(d/d_o) + X$; or “2-ray”

- Delay dispersion

- RMS-delay spread σ_τ
- Coherence BW $B_c \sim 1/\sigma_\tau$

- Time Variation

- Doppler spread f_D & coherence time $t_c \sim 1/f_D$

- Inter-antenna/band correlation

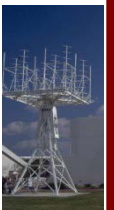
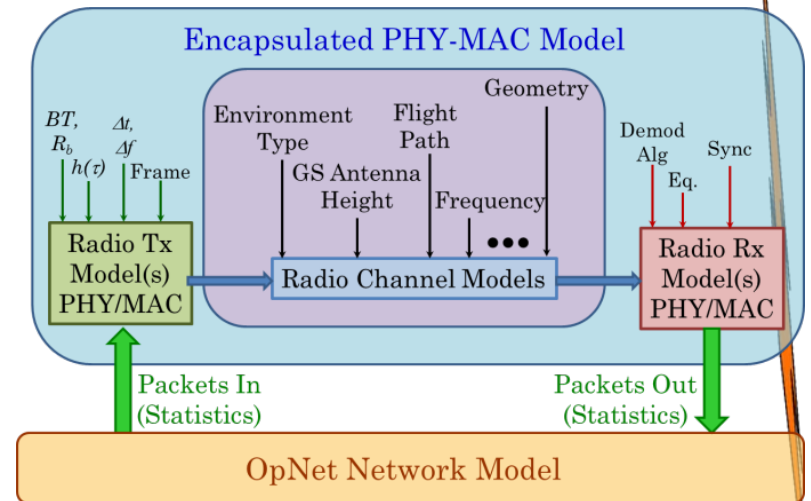

Channel Effects



- Current comm. systems: 3 main chan. effects
 1. **Large scale path loss**: function of Tx-Rx distance d ; typically $\sim d^n$, $n \sim 2-7$
 - Attenuation, spreading or basic transmission loss
 2. **Small scale fading**: “local” phenomenon, often nearly independent of Tx-Rx distance
 - Occurs on spatial scales $\sim \lambda/2$ —**multipath**
 3. **Shadowing**: blockage or obstruction of LOS
 - Related to **diffraction**

Channel Attenuations

- Graphically (extension of plot in [Sklar]); with P_t , G 's constant

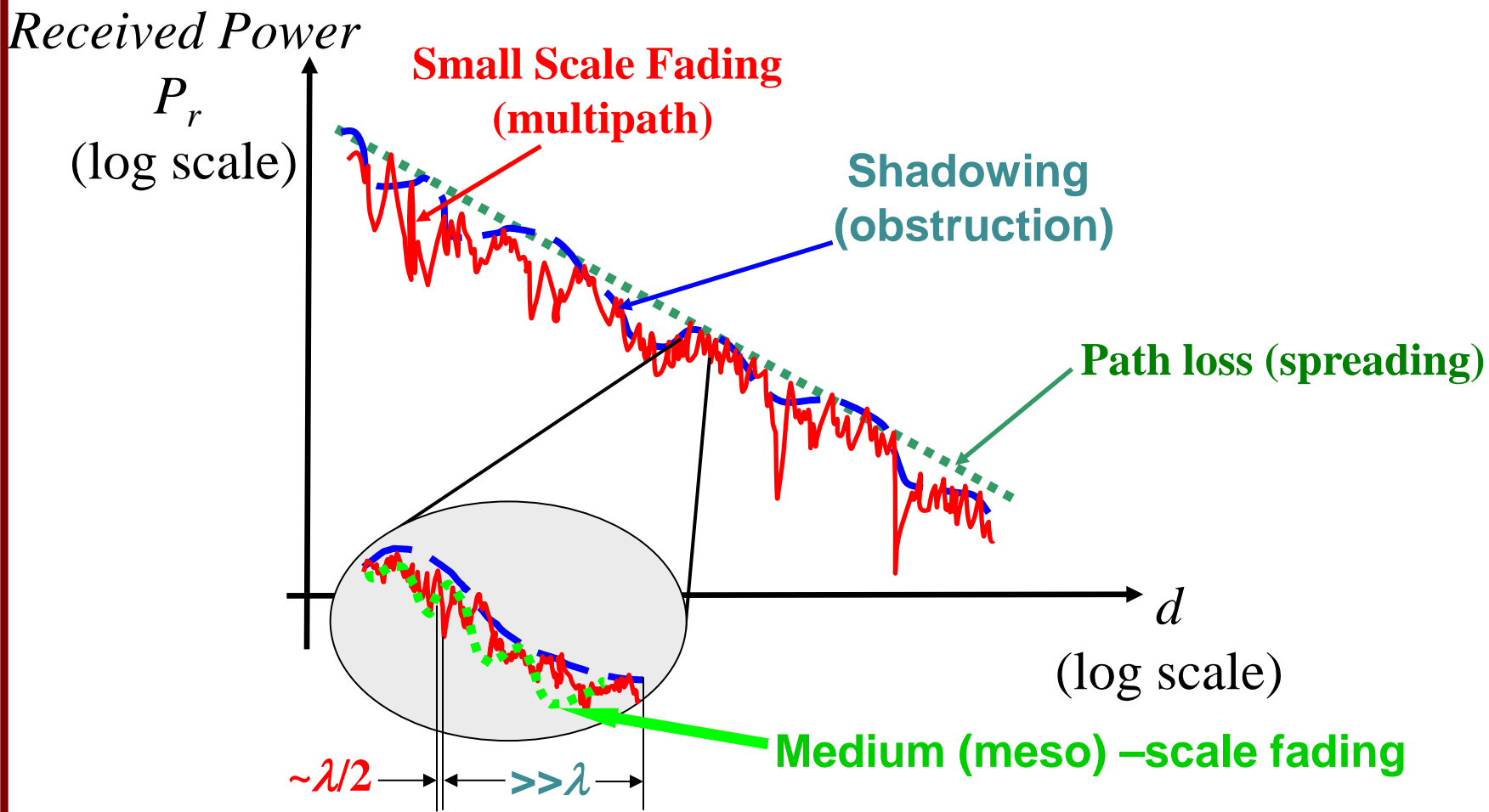

Channel Models

- For communications (& radar, navigation, etc.), want **model** for what channel does to signals
- Simplest model is

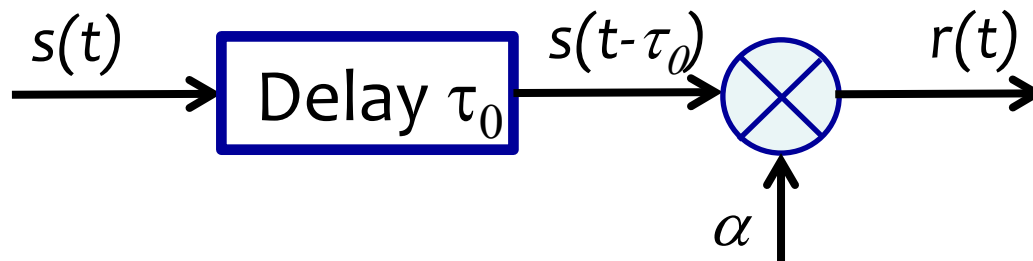

- $s(t)$ = transmitted signal, bandpass
- α = channel gain
- $r(t)$ = received signal

Valid for AG channel (e.g., enroute) when GS in OPEN area, & surface reflection minimal/mitigated

Channel Models (2)

- Simplest model is **distortionless**

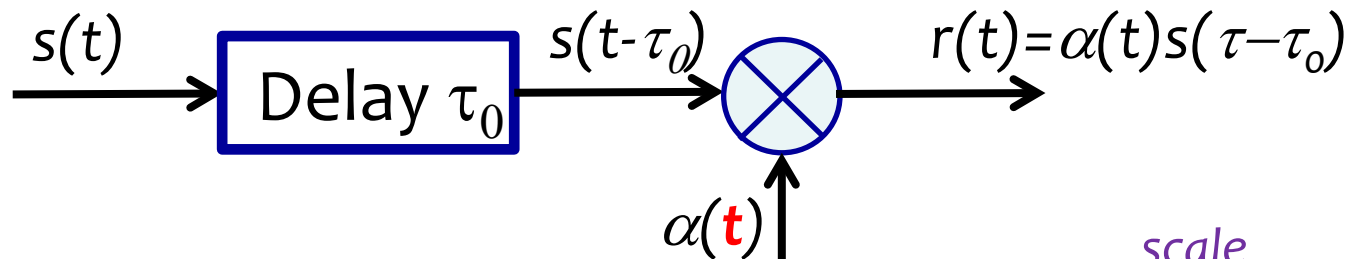

- Channel impulse response (CIR) $h(\tau, t) = \alpha(t) \delta(\tau - \tau_0)$
 - Transfer function $H(f, t) = \alpha(t) \exp(-j2\pi f \tau_0)$
 - gain ↗
 - linear phase ↖
 - scale ↓
 - delay ↓
 - Model can interchange order of **delay** & **gain** (**linear**)
 - In general, both τ_0 and α are **time varying**

Canonical Channel Model

- For digital comm., send symbol **sequences** $\{x_k\}$
- Linear, time-varying (LTV) channel modeled by FIR filter, “tapped-delay line” (TDL)

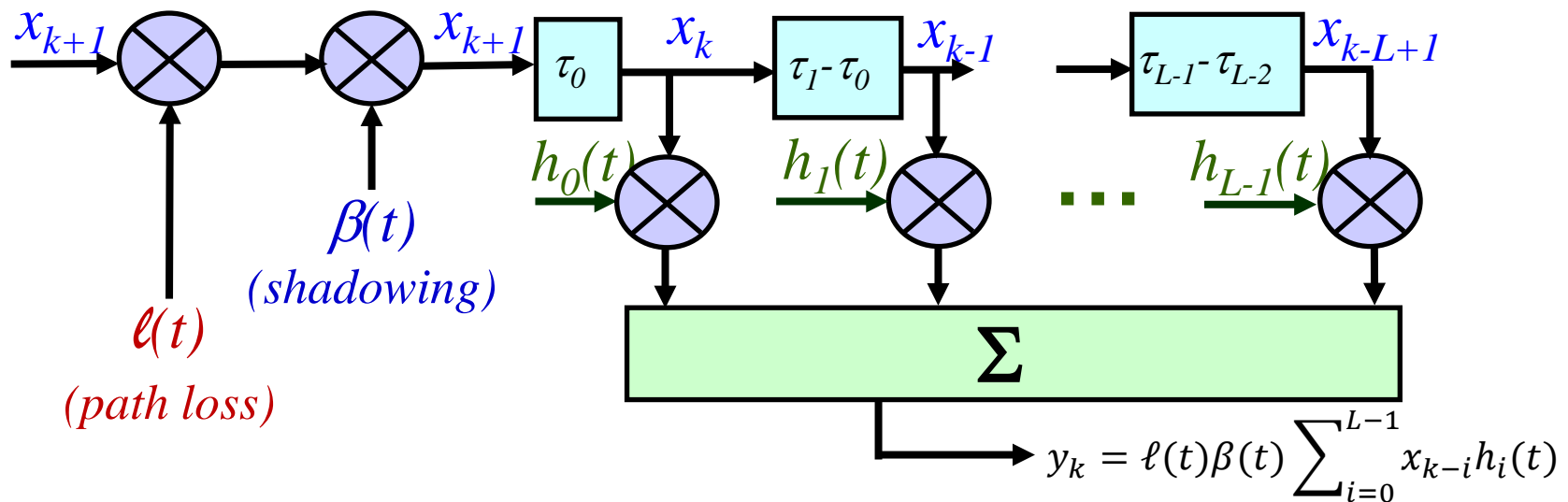

Delay dispersion \Leftrightarrow Frequency selectivity

Time variation \Leftrightarrow Spectral broadening

Channel Characteristics



- Channel is *linear, time-varying* system

⇒ Completely characterized by **channel impulse response** (CIR) $h(\tau, t)$ (or $\mathbb{F}\{h(\tau, t)\} = H(f, t)$)

$$h^{(c)}(\tau, t) = \sum_{k=0}^{L(t)-1} z_k(t) \alpha_k(t) \exp\{j[\omega_{D,k}(t)(t - \tau_k(t)) - \omega_c(t)\tau_k(t)]\} \delta[\tau - \tau_k(t)]$$

“birth/death” → $z_k(t)$
 amplitude of k^{th} MPC → $\alpha_k(t)$
 Doppler of k^{th} MPC → $\omega_{D,k}(t)$
 phase of k^{th} MPC → $\omega_c(t)\tau_k(t)$
 Dirac delta → $\delta[\tau - \tau_k(t)]$
 delay of k^{th} MPC → $\tau_k(t)$

Channel Parameters & Effects

Channel Parameters	Affected Signal/System Design Parameters
Multipath delay spread T_M , & coherence bandwidth B_c	Signal & subcarrier bandwidths, symbol rate, cyclic prefix or equalizer length
Channel attenuation α	Transmit power P_t , link range, modulation/FEC/detection, data rate R_b
Doppler spread f_D , & coherence time t_c	Data block/packet size, signal & subcarrier bandwidths, FEC type/strength, transceiver adaptation rates, duplexing method
Spatial/temporal correlations ρ_s, ρ_t	Diversity method, FEC type, multiplexing method, antenna design

Channel affects availability, integrity, latency

Channel Parameters & Effects (2)

- How channel model affects **spectrum**
 - **Dispersion** affects signal **bandwidth** (\Rightarrow data rates)
 - **Path loss, shadowing** affect link **range**
 - This affects frequency re-use distance \Rightarrow *capacity*
 - **Rate of time variation** affects **packet size**
 - Variation rate \Rightarrow “burst” length, which for given data rate, specifies signal bandwidth

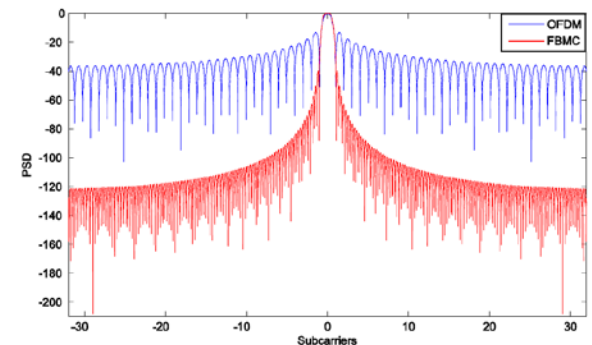

Channel Modeling



- Channel modeling **complexity** ↑ over time
 - Increased **accuracy** for higher system reliability
 - **Wider** signal **bandwidths**



- Model types/examples

- Free-space
- 2-ray
- MPCs (TDL)
- Deterministic (HF, e.g., ray tracing)
- Statistical
- **Hybrid/combination**



Aeronautical Channels

- Types

- Air-to-Ground (AG) ~ Ground-to-Air (GA) x
- Air-to-Air ~x

- Aircraft “phases of flight”

- En route (✓ for conventional links)
- Takeoff/Landing ~ x (✓ for conventional links)
- Taxiing & Parking (GG)
 - Done for airport surface area [DWM, DLR] ✓

[Cleveland Hopkins International Airport]

NASA AG Chan. Measurements



- Simultaneous **dual-band** 1 x 2 measurements
- Six-seven distinct environments
- Power delay profiles for estimating
 - Path loss, small-scale fading
 - Delay dispersion
 - Doppler
 - Correlations

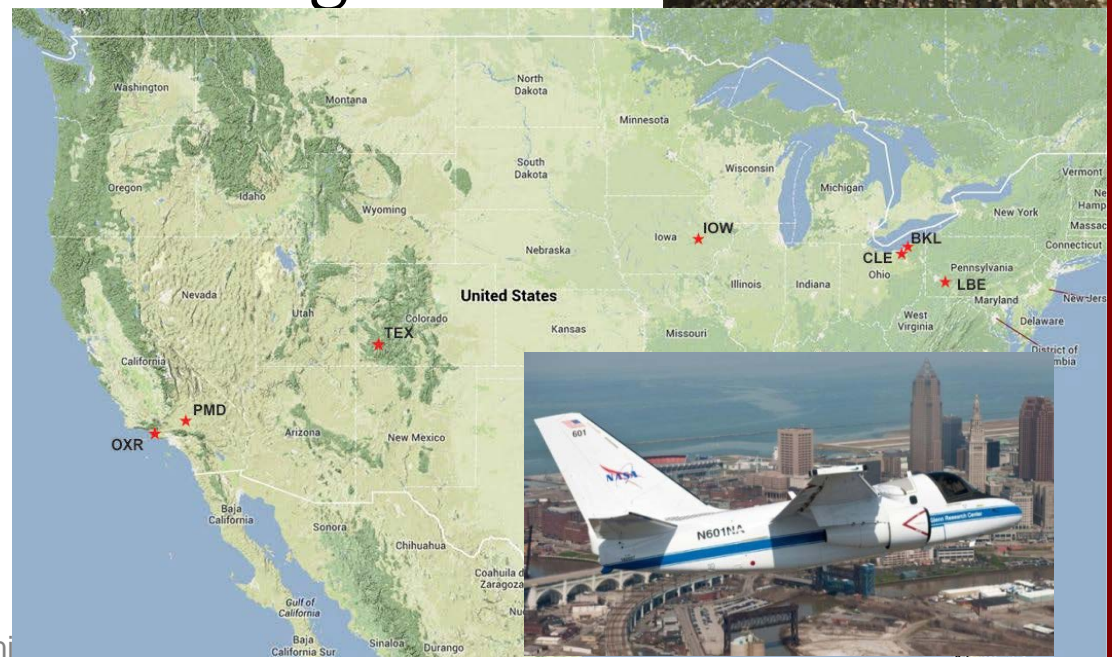
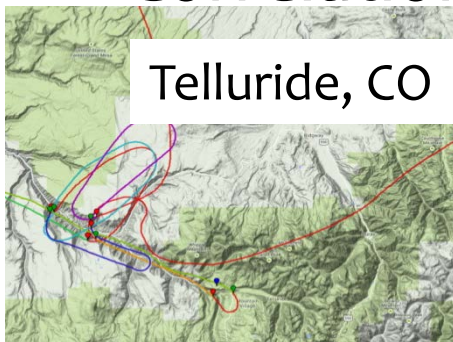

Measurement Equipment

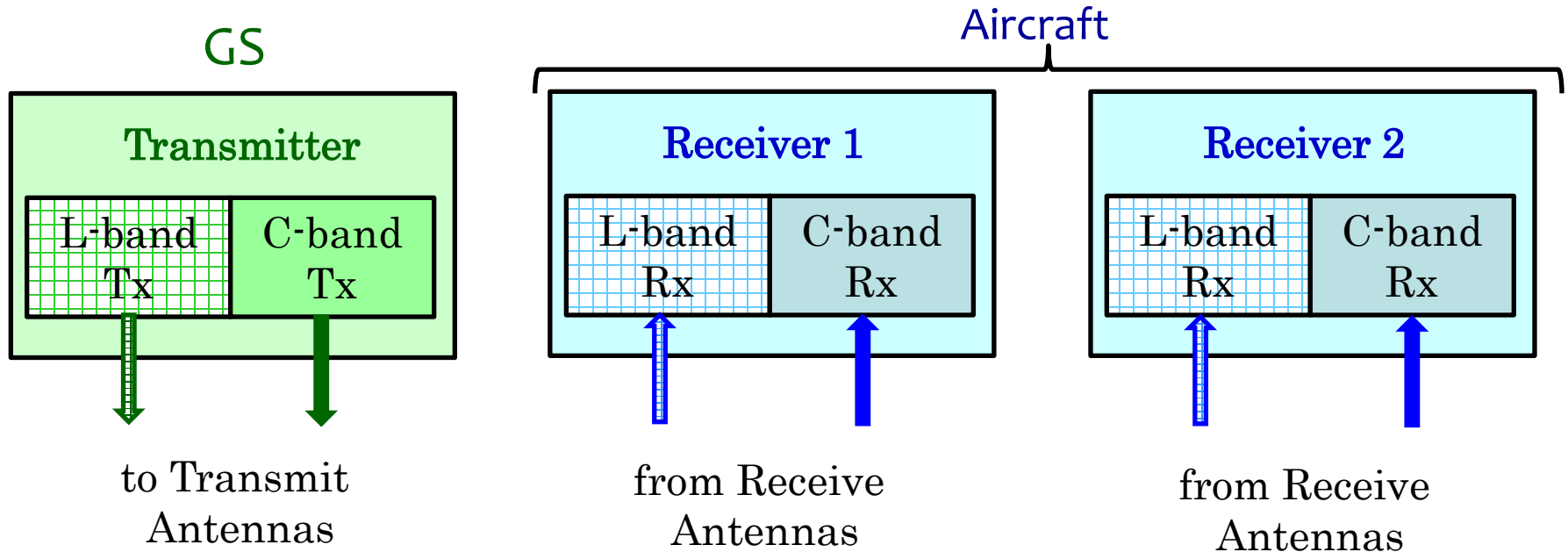

Band	Signal Bandwidth (MHz)	Frequency Span (MHz)
L	5	960-977
C	50	5000-5100

Band	DS-SS Sequence Length N	τ_{MAX} (μs)
L	511	102.2
L	1023	204.6
C	511	10.2
C	1023	20.4

- $P_{TX} \sim 10$ W (40 dBm)
- C-band: HPA $G \sim 7$ dB, LNAs $G \sim 30$ dB
- $R_{rep,max} \sim 3$ kHz

Dual-Band Channel Sounder

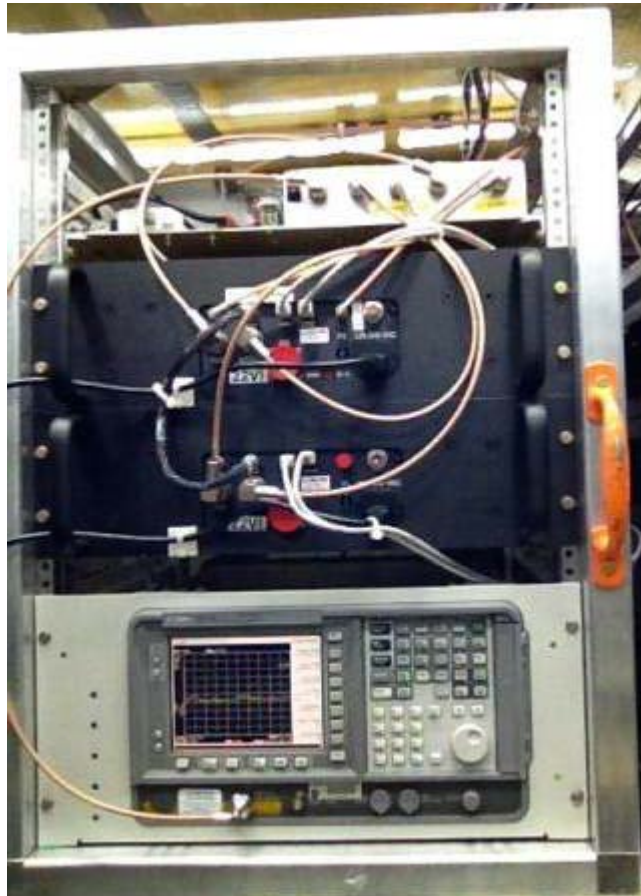

Spectrum Analyzer



Transmitter
(at GS)

Receivers
(Qty 2)



Each Rx chassis contains
1 L-band & 1 C-band Rx

Measurement Equipment (cont'd)

- Transportable ground site (GS), S-3B aircraft



20 m extendable tower



Four receiver (Rx) antennas:
2 in C-band, 2 in L-band

AG Channel Modeling Procedure

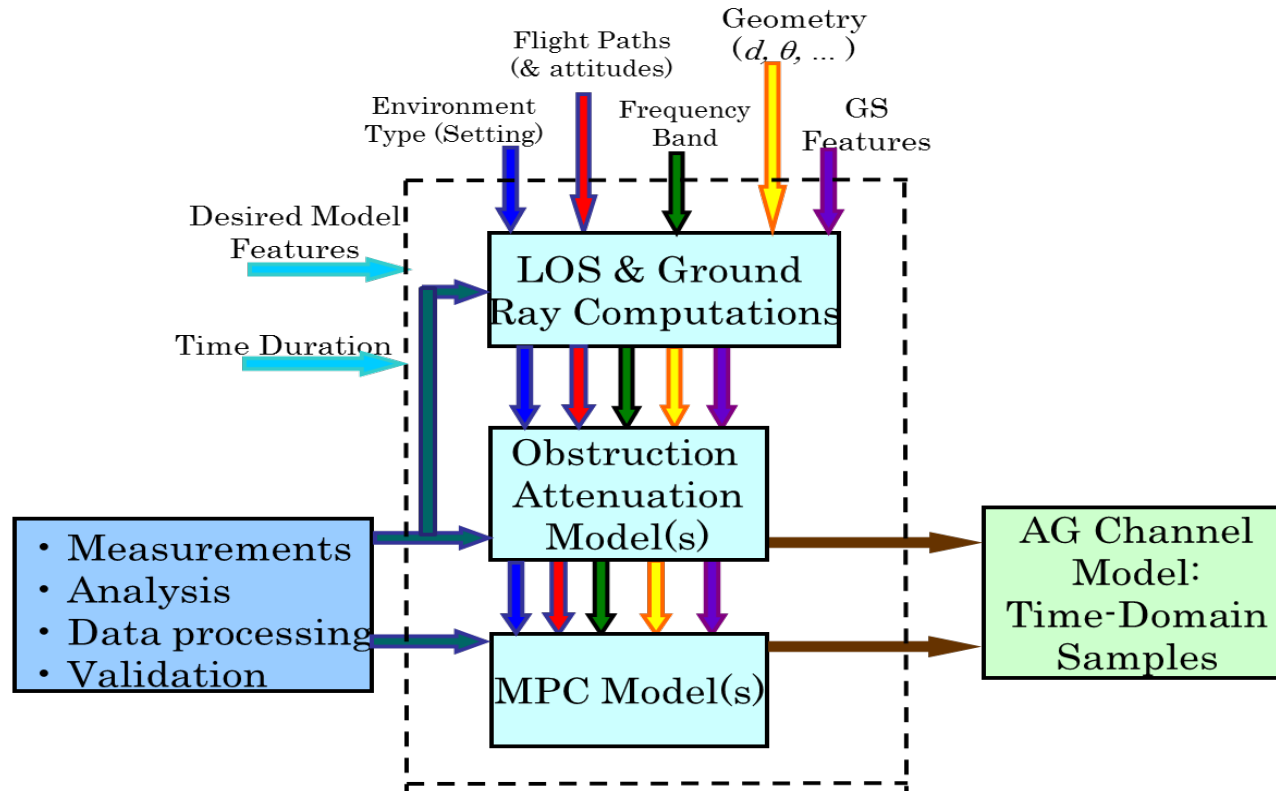

$$h_{OverSea}(\tau, t) = \alpha_0(t)e^{-j\phi_0(t)}\delta(\tau) + \alpha_s(t)e^{-j\phi_s(t)}\delta(\tau - \tau_s(t)) \\ + z_3(t)\alpha_3(t)e^{-j\phi_3(t)}\delta(\tau - \tau_s(t) - \Delta\tau_3(t))$$

Channel Modeling → Radio → Network

1. AG Channel Modeling

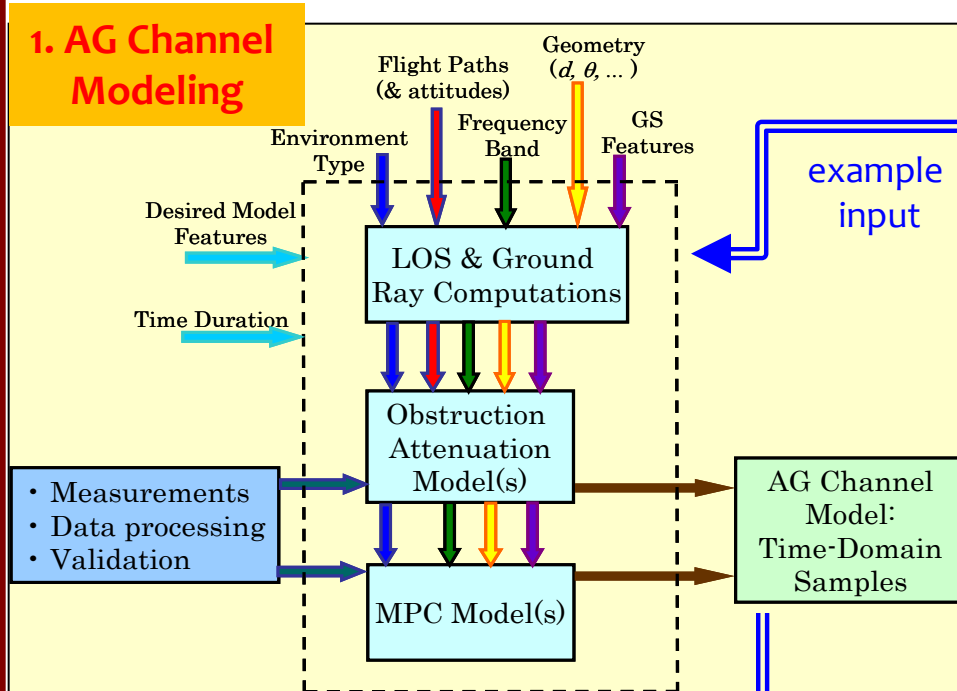

2. Channel Model Implementation

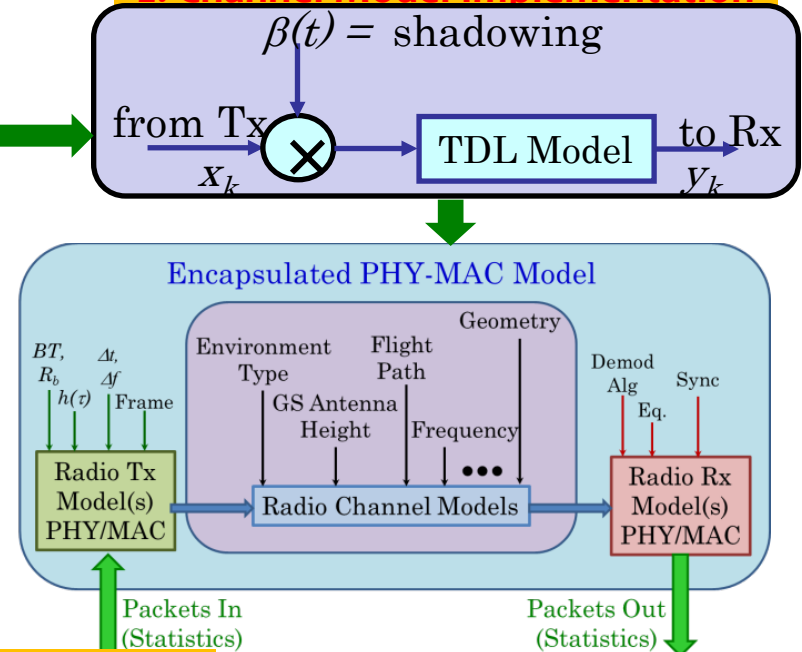

Variation of Ricean K-factor
Mountainous terrain

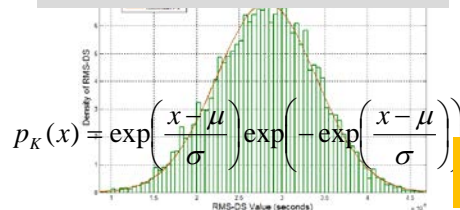

3. Network Model Integration

OpNet Network Model

Measurement Results: Path Loss

- Over-water best model: CE2R + Ricean

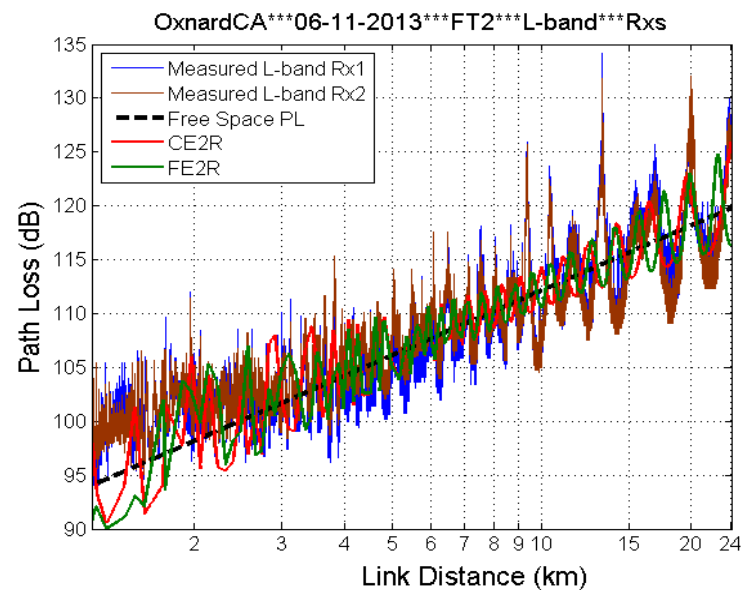
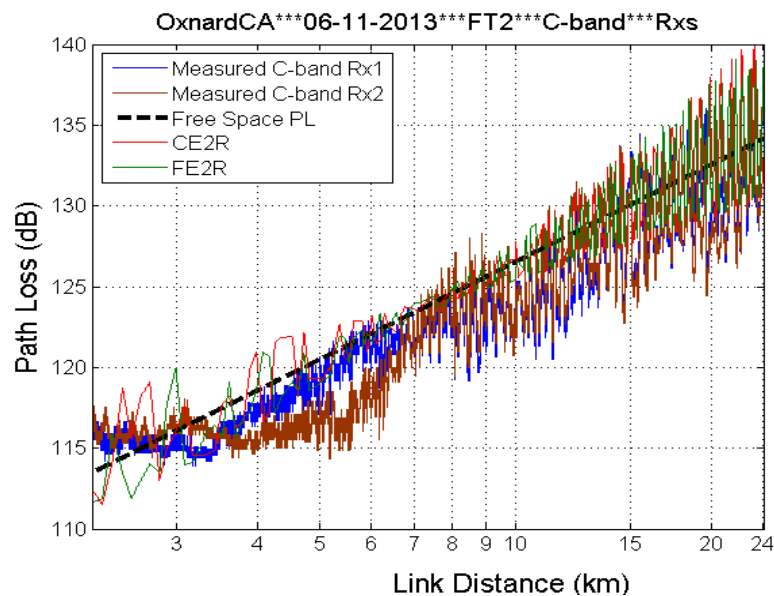

- CE2R approximates shape vs. range better than log-distance models
 - Ricean models surface scattering

Airframe Shadowing



- Example shadowing events, statistics

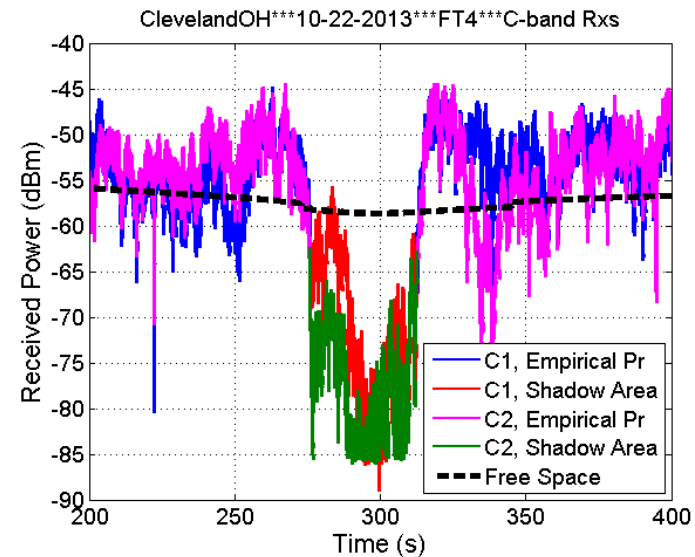
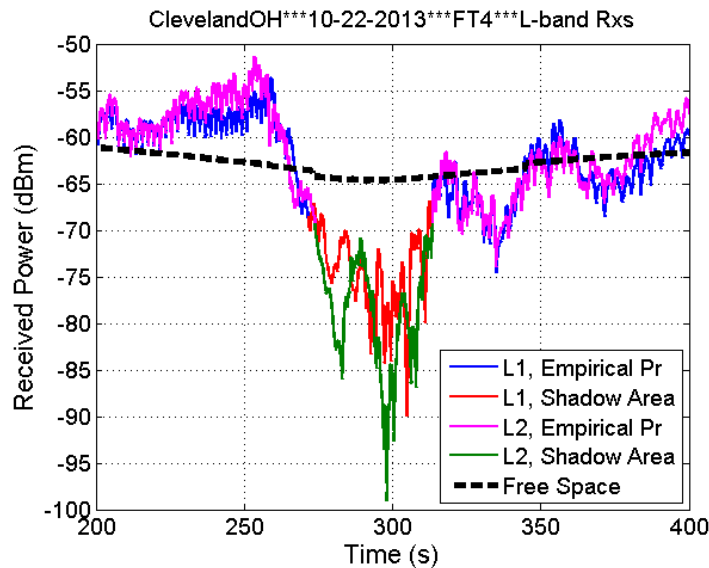

Over-Freshwater Statistics		C-band		L-band	
		Rx1	Rx2	Rx1	Rx2
Shadow Duration (s)		36.5	37.3	41.9	39.8
Shadow Loss (dB)	Max	30.4	27.5	25.5	34.4
	Min	0	4.2	2.6	5.0
	Mean	9.1	17.2	10.3	14.2
	Median	6.3	16.9	9.6	12.9
	Standard Deviation	7.4	6.4	4.4	5.9
Distance (km)	Max	21.8	21.8	21.8	21.8
	Min	20.5	20.5	20.1	20.3

Example: Hilly Terrain RMS-DS

- RMS-DS vs. distance

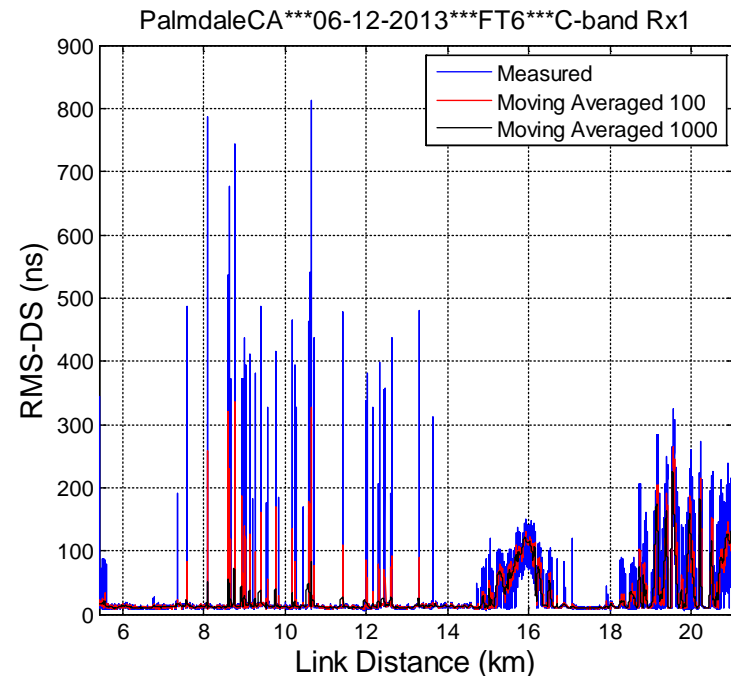
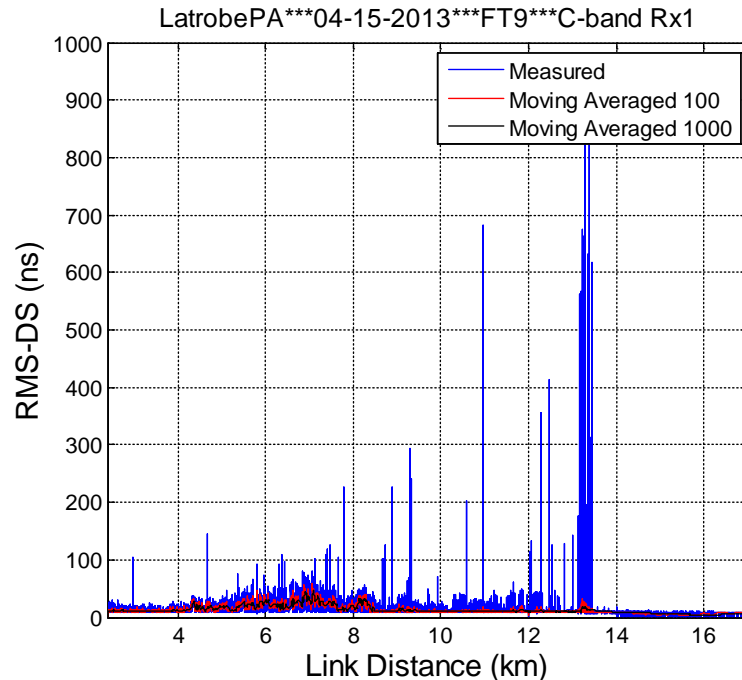

- “Spikes” not anomalies/noise: *intermittent MPCs due to terrain, buildings, etc.*

Hilly Terrain PDPs, RMD-DS Stats

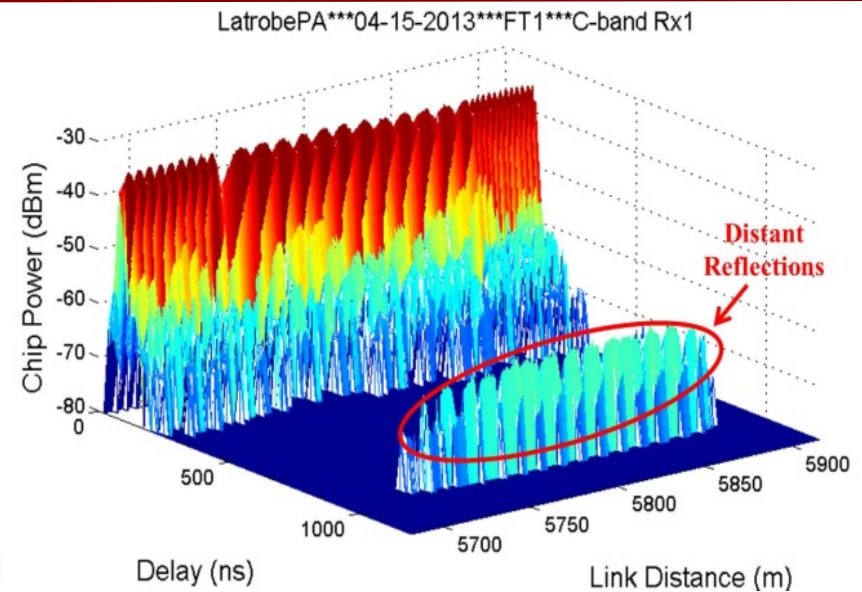
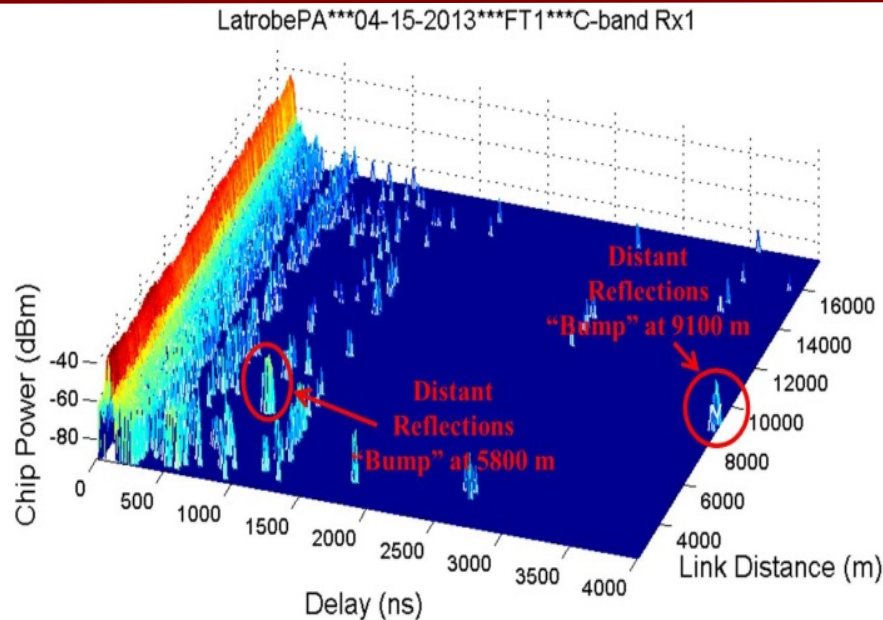

RMS Delay Spread		Mean (ns)	Median (ns)	Max (ns)	Standard Deviation (ns)
FT1	Original	12.9	10.9	267.2	9.8
	Moving Averaged, 100 PDPs		11.1	87.0	6.6
	Moving Averaged, 1000 PDPs		11.2	57.0	5.7
FT6	Original	35.7	10.9	995.7	55.7
	Moving Averaged, 100 PDPs		18.6	371.8	42.9
	Moving Averaged, 1000 PDPs		19.3	349.2	40.4

(profile animation)

Wideband Modeling

- Traditional TDL

- For over-water

- component 1=LOS
 - component 2=surface reflection
 - component 3=*intermittent 3rd ray*

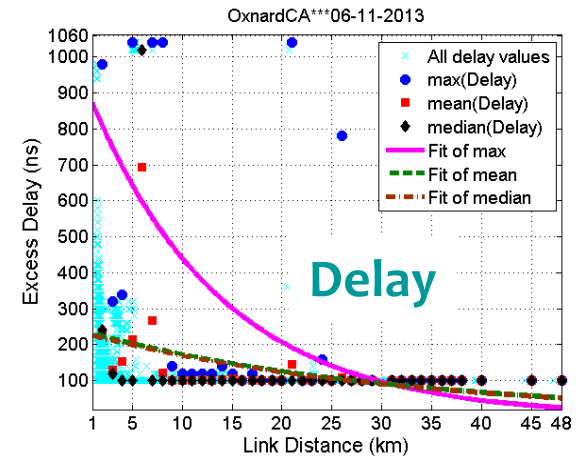
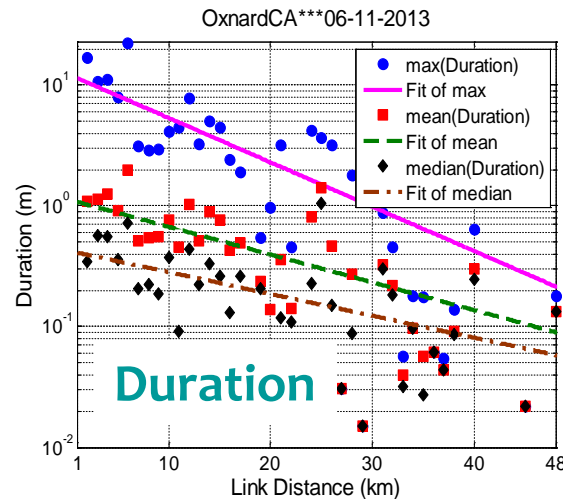
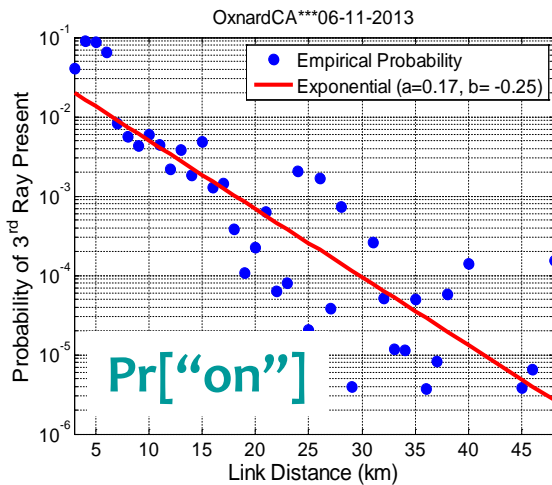
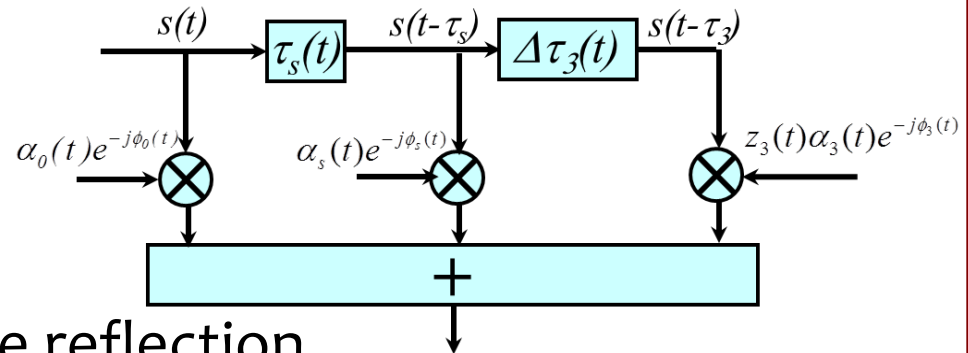

Additional Models, TBDeveloped

- Hilly & mountainous terrain
- Suburban & near-urban
- Airframe shadowing

- Small UAS!

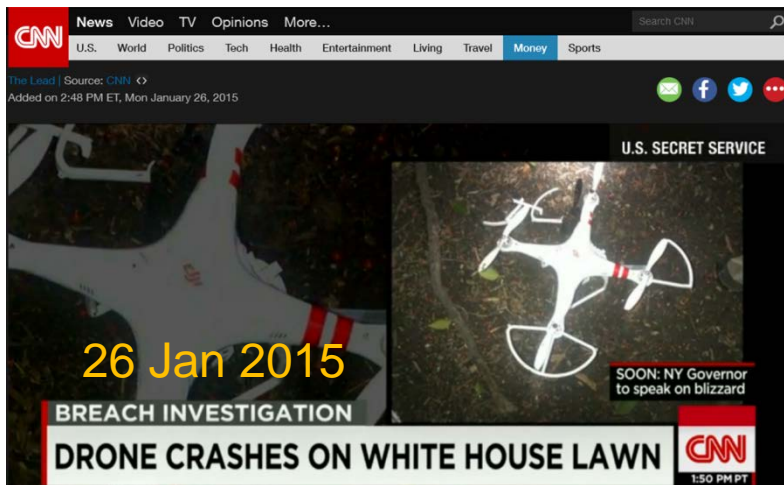

Summary



- Mobile radio—AG—communications requires **accurate channel characterization** for **high reliability**
- Complete channel characterization/modeling
 - CIR $h(\tau, t)$ or CTF $H(f, t)$
 - Path loss, small-scale fading, shadowing, # MPCs, correlations...



Summary (2)



- AG channel investigated *much less* than other channels (narrowband signals, high GS in open area...)
- Setting (GS) & flight path significantly affects
 - Presence/absence of LoS (range, fading severity)
 - Density of *scatterers* (dispersion, distortion)
 - Rate of time variation (Doppler)
- **Channel modeling work ongoing!**



Questions?



Thank You!