

MACHINE READABLE TRAVEL DOCUMENTS



TECHNICAL REPORT

DURABILITY OF MACHINE READABLE PASSPORTS

Version: **3.2**
Date: 2006-08-30

Published by authority of the Secretary General

INTERNATIONAL CIVIL AVIATION ORGANIZATION

Preface

Document History

This document is based on decisions taken at WG3 Meeting Singapore, October 6 - 8, 2003. As a consequence, new taskforces were created, one of these dealing with the test methods and requirements for MRTDs with contactless integrated circuits. The initial discussion in this taskforce resulted in a proposal to create a strawman draft specification using the work done by another team of experts as presented to the ICAO TAG-MRTD during its 14th session as Working Paper 22.

WP/22 is composed of TF documents WG3TF4_N0003_TAGMRTD.14.WP.022.App.en.doc and WG3TF4_N0002_TAGMRTD.14.WP.022.en.rtf

The original TF proposal is described in TF document WG3TF4_N0008_eMail_Otto_Rationale_ePassportTest.pdf

At ICAO/TAG 16, Montreal, Canada, September 26-28, 2005, WG3/TF4 presented working paper 14 (TF4 document WG3TF4_N0116_TAG16 WP Durability NTWG V2.DOC). This document asked the TAG to acknowledge the work already accomplished by WG3/TF4 and to endorse the continued development of a minimum durability specification – in the form of a Technical Report.

Editorial Explanatory note

Italic style is used for explanatory comments in the drafting stage and is not meant to remain in the final text. The color of text used is not of significance. Color is used in some instances to better visualize insertions and definitions, etc.

Revision History

Version	Date	TF4 Doc No.	Description
0.1	2003-11-17	0022	Critical review and adaptation of basic principles using TF doc no 002
0.1a	2004-01-20	0023	Revision of v. 0.1 Content added to sections 3 upward (Definitions, Stress Methods, Evaluation Methods, Test Procedures, _Test Scenarios)
0.2	2004-03-14		Dealing with comments implied in v.0.1a
0.3	2004-03-19		Some editorial and opinion comments
0.4	2005-03-04		Major revision introducing test plan concept and removing direct source tracking references to WP22
0.5	2005-09-26	0117	First draft to include all submissions from contributing editors
0.6	2005-11-23		Result of editorial session in Paris, November, 2005
1.0	2006-02-10	N0147	Output from Ottawa meeting. Re-worked document
2.0	2006-05-12	N0182	Technical re-write contribution from ISO SC17/WG1 from ad-hoc meeting
3.0	2006-08-16	N225	Results from meeting in Graz, June 2006
3.1	2006-08-23	N0230	Final Committee draft from TF4D after Ottawa meeting
3.2	2006-08-30	N0232	Update of dynamic bend method

Table of Contents

1	Introduction	6
1.1	Scope and Purpose	6
1.2	Future Considerations	6
1.3	Other Uses for this Document	6
1.4	Terminology	7
1.5	Abbreviations	7
1.6	Terms and Definitions	7
1.7	References	9
2	Methodology	10
3	Guidance to the Tester	12
3.1	Number of Samples	12
3.2	Preparation	12
3.3	Sampling	12
3.4	Storage	12
4	Common Method Information	13
4.1	Default Environment	13
4.2	Climatic conditions	13
4.3	Tolerances	13
4.4	Default MRP holder	13
5	Stress Methods	14
5.1	Conditioning Stress Method	14
5.2	Thermal Cycling Method	15
5.3	Storage Temperature Stress Method	16
5.4	Operational Temperature Stress Method	17
5.5	Impact Stress Method	18
5.6	Book Bend Stress Method (Back Pocket)	20
5.7	Dynamic Bend Stress Method	22
5.8	Torsion Stress Method	25
5.9	Sheet Turning Stress Method	27
5.10	Sheet Pull Stress Method	28
5.11	Abrasion Stress Method	29
5.12	Pen Stress Method	30
5.13	Resistance to chemicals Evaluation Method	32
5.14	Artificial Daylight Exposure Stress Method	34
5.15	X-Ray Stress Method	35
6	Evaluation methods	36
6.1	Functional PIC Evaluation Method	36
6.2	Physical Damage Evaluation Method	37
6.3	Peel Strength Evaluation Method	38
6.4	Colour Fastness Evaluation Method	39
6.5	Datapage Warpage Evaluation Method	40
6.6	Book Warpage Evaluation Method	41
7	Test sequences	42
7.1	General	42
7.2	Instructions for using the Sequence Table	42
7.3	Sheet Binding Sequence	43
7.4	Storage Climate Sequence	44
7.5	Operational Climate Sequence	45
7.6	Impact Sequence	46
7.7	Back Pocket Sequence	47
7.8	Torsion Fatigue Sequence	48
7.9	Delamination Sequence	49
7.10	Bending Fatigue Sequence	50
7.11	Thermal Cycling Sequence	51
7.12	Colour Fastness Sequence	52
7.13	Resistance to Chemicals Sequence	53
7.14	Pen Sequence	54
7.15	Datapage Abrasion Sequence	55
7.16	X-Ray Sequence	56
8	Test plans	57

8.1 General	57
8.2 Minimum Level Test Plan	58

1 Introduction

1.1 Scope and Purpose

ICAO Doc. 9303, [R7], provides the basic functional specification for Machine Readable Travel Documents (MRTDs) and, together with the Supplement, [R10], which is published from time to time, describes all relevant properties of MRTD's. Machine Readable Passports (MRP's) are a subset of all MRTD's. The publication of the Part 1 of the 6th edition of Doc 9303 introduces the contactless integrated circuit to the MRP. Such a passport containing a contactless integrated circuit is commonly referred to as an e-Passport.

This Test Specification provides a set of instructions for prototype evaluation of MRP's which may incorporate contactless integrated circuits. Prototype evaluation is an instrument to establish the ability in principle of a specific type of document to fulfil the requirements of use. The procedure of prototype evaluation, therefore, is also referred to as "Type Evaluation".

This document is a companion to ICAO Doc. 9303. It specifies the minimum criteria that shall be achieved in order to meet ICAO's expectations for durability of fully personalized MRP's. Therefore, by its existence, and endorsement by ICAO, this document implicitly defines additional requirements for Passports above and beyond Doc. 9303. Some of the tests described herein are also intended to serve as an instrument for the assessment of the ageing behaviour of the MRP and its components.

1.2 Future Considerations

Where technologies or combinations of technologies are to be applied in a MRP, which are not covered by the test methods described below, it is recommended to define such test methods based on available methods described in ISO/IEC, ANSI or any other accepted international standard organization in cooperation with the suppliers of such technologies.

Today, there is no stable state of the art regarding the correlation between stress and ageing, neither for previously existing nor for oncoming types of MRP. Related work by SC17/WG1/TF2 is still under way. The tests that can be described at the present stage may contribute to improve such knowledge but need to be considered preliminary. It is important to notice that ultimately, reliable and predictably useful correlations can only be achieved by continuously comparing the ageing behaviour of documents in real use to the predictions made. Such predictions are based on assumptions that, in particular if novel and unusual technologies and components are used, are in many cases unproven and preliminary in nature. It is one of the aims of this standard to help in the task of establishing sound correlations. This is done by providing tools for executing tests with comparable results for a multitude of acting parties. Comparable results are a prerequisite to encourage the execution of field surveys in quality related research and their use for a continuous improvement not only of this standard but also of the quality of MRP's on a global basis.

1.3 Other Uses for this Document

The tests defined in this document may also be appropriate for other forms of MRTD, however, they may require modification before use.

Where applicable, tests may be used to evaluate characteristics of non-personalized MRP's or materials used to make MRP's.

Type Evaluation is usually a one-time exercise in the life cycle of a specific type of document. However the same test procedures may be useful for the proper definition of quality assurance procedures during the regular production of MRTD's. In the framework of the contractual relationship between a manufacturer and his customer(s) it is common practice to establish an expected quality level for the MRTD's in the delivery contract, and also to specify acceptance criteria for individual deliveries in executing the contract. On the other hand, it is good practice to leave it with the manufacturer to decide on the production quality measures to assure this quality level.

This specification has been carefully designed to provide the user with a set of tools for evaluating MRP's, whether it be Prototype Evaluation, Delivery Acceptance, or any other purpose.

Because of the paramount importance of a common understanding between manufacturer and customer of the role of testing procedures in the production of security documents, an informative

annex A may be included in a future version of the standard which gives a more detailed best practice survey of the principles of quality assurance and of the role that the present standard is expected to play in this context.

1.4 Terminology

For ICAO, keywords are SHALL, which means mandatory, and SHOULD, which is optional but is considered best practices.

1.5 Abbreviations

ICAO	International Civil Aviation Organization
MRP	Machine Readable Passport
MRTD	Machine Readable Travel Document
PIC	Proximity Integrated Circuit (note, Doc 9303 uses CIC (contactless integrated circuit) and PIC interchangeably)

1.6 Terms and Definitions

Constant	Fixed values that can be given to parameters (within methods) when defining a sequence or test plan.
Evaluation Method	method to measure numerical values for specific document properties
Evaluation Result	All numerical values related to document properties measured upon performing a Test Sequence.
Method	Instruction or set of instructions defining equipment and related tools and materials in an experimental setup, including general advice on their use in a specific test procedure.
Page	indicates any single side of an individual sheet of the MRP.
Parameter	A variable quantity within a test procedure that is not part of the instructions describing the procedure. In particular experimental parameters that need to be controlled during the test sequence but whose values and/or tolerances are not explicitly defined in a specific Stress or Evaluation Method or sequence.
Sheet	any structure having a free edge and an opposite edge attached to the spine making up the MRP including covers, datapage, visa pages, observation pages, and chip sheet. Each sheet has 2 pages.
Stress Method	An experimental setup and procedure that may or may not deteriorate or destroy the document under examination.
Test instruction	A distinct piece of information required within the framework of test execution.
Test plan	A list of Test Sequences and their specific Test Parameters and expected Evaluation Results.
Test procedure	Set of instructions to be followed in order to obtain a test result.
Test sequence	Test procedure that comprises a number of different methods in a defined order of execution.

Type Evaluation or Type Approval Type approval is the process of testing a design (type of documents produced while using a common material and component basis and the same manufacturing processes, including same production quality assurance process) to ensure it is compliant-in-principle with the specifications.

1.7 References

The following normative documents contain provisions that, through reference in this text, constitute provisions of this technical report. For dated references, subsequent amendments to, or revisions of, any of these publications do not apply. However, parties to agreements based on this technical report are encouraged to investigate the possibility of applying the most recent editions of the normative documents indicated below. For undated references, the latest edition of the normative document referred to applies.

- [R1]** ISO/IEC 10373-1:2006, Test methods — Part 1: General characteristics
- [R2]** ISO/IEC 10373-6:2001, Test methods – Proximity cards
- [R3]** ISO/IEC 10373-6:2001/FDAM1, Test methods – Proximity cards (Amendment 1: Protocol Test Methods for Proximity Cards)
- [R4]** ISO/IEC 10373-6:2001/AM2:2003, Test methods – Proximity cards (Amendment 2: Improved RF Test Methods)
- [R5]** ISO/IEC 10373-6:2001/FDAM4, Test methods – Proximity cards (Amendment 4: Additional Test Methods for PCD RF Interface and PICC Alternating Field Exposure)
- [R6]** ISO/IEC 10373-6:2001/FDAM5, Test methods – Proximity cards (Amendment 5: Bit Rates of fc/64, fc/32 and fc/16)
- [R7]** ICAO Doc 9303, Part 1, 6th edition, 2005, Machine Readable Travel Documents.
- [R8]** ISO 105-E04:1994, Textiles - Tests for colour fastness - Part E04: Colour fastness to perspiration.
- [R9]** ISO/IEC 7816-1, Identification cards – Integrated circuit cards – Part 1: Cards with contacts – Physical characteristics
- [R10]** ICAO Supplement to Doc 9303 as published from time to time.
- [R11]** ISO/IEC 7810, Identification cards - Physical characteristics.
- [R12]** TAG-MRTD/14-WP/22: Recommendations on Durability Measurement of Travel Documents, May 2003
- [R13]** ISO 12757: Ball point pens and refills
- [R14]** ISO 1817: Rubber, vulcanized - Determination of the effect of liquids
- [R15]** ISO 9227:1990: Corrosion tests in artificial atmospheres – salt spray tests
- [R16]** ISO 1302: Geometrical Product Specification (GPS) – Indication of surface texture in technical product documentation
- [R17]** RF Protocol and Application Test Standard for e-Passport – Part 2, WG3TF4_N0163, Version 0.9, 2006-02-10
- [R18]** ASTM E 832 – 81 (Reapproved 2003): Standard Specification for Laboratory Filter Papers
- [R19]** ISO 105-A02:1993: Textiles – Tests for colour fastness – Part A02: Grey scale for assessing change in colour
- [R20]** ISO 105-A02:1993 TECHNICAL CORRIGENDUM 2 (2005): Textiles – Tests for colour fastness – Part A02: Grey scale for assessing change in colour TECHNICAL CORRIGENDUM 2
- [R21]** ISO 105-B02:1994: Textiles – Tests for colour fastness – Part B02: Colour fastness to artificial light: Xenon arc fading lamp test
- [R22]** ISO 105-B02:1994 AMENDMENT 1 (1998): Textiles – Tests for colour fastness – Part B02: Colour fastness to artificial light: Xenon arc fading lamp test AMENDMENT 1
- [R23]** ISO 105-B02:1994 AMENDMENT 2 (2000): Textiles – Tests for colour fastness – Part B02: Colour fastness to artificial light: Xenon arc fading lamp test AMENDMENT 2
- [R24]** ISO 12040:1997: Graphic technology – Prints and printing inks – Assessment of light fastness using filtered xenon arc light

2 Methodology

The systemic approach used in this document provides three structural levels to define a complete test specification for MRP's.

The first level deals with methods to exert defined stresses to documents and to evaluate the results of such stresses. The second level deals with predefined sequences of stresses and related evaluations using the methods defined in level 1. The third level specifies the lists of test sequences and the individual quantities of test specimens to be subject to each sequence. The purpose is to include in such lists all sequences that are considered necessary to achieve type approval for a specific type of MRP with specific lifetime and usage expectations. This is referred to as a test plan.

This approach provides flexibility in creating individual test plans appropriate for varying user requirements and MRP specifications without increasing the variety of basic testing methods beyond a strict minimum. It also allows the use of a parameterized method description; parameters, which may be explicitly specified on the sequence and/or test, plan level.

In this way this Test Specification provides the entire toolset for prototype evaluation of MRP's.

Level	Subject	Description	Degree of variance	Chapter
1	Stress methods	The purpose is to submit the document(s) under evaluation to specific stress or environmental conditions in a well-defined experimental setup that ensures reproducibility.	Parameters	4
1	Evaluation methods	The purpose is to measure numerical values for specific document properties using well-defined and reproducible experimental setups that may or may not deteriorate or destroy the document under examination.	Parameters	5
2	Test sequences	Sequence of use of the above methods in performing a complete test.	Constants and Parameters	6
3	Test plans	Scenarios which link the user requirements to specific test sequences and related parameters used for the tests on the one hand and to specific test results on the other.	Constants	7

Table 1: Hierarchical Approach for Test Methodology

Each sequence is composed of stress methods and evaluation methods executed in a specific order. A test plan is composed of one or more individual sequence(s) that is linked to a specific set of documents and user requirements.

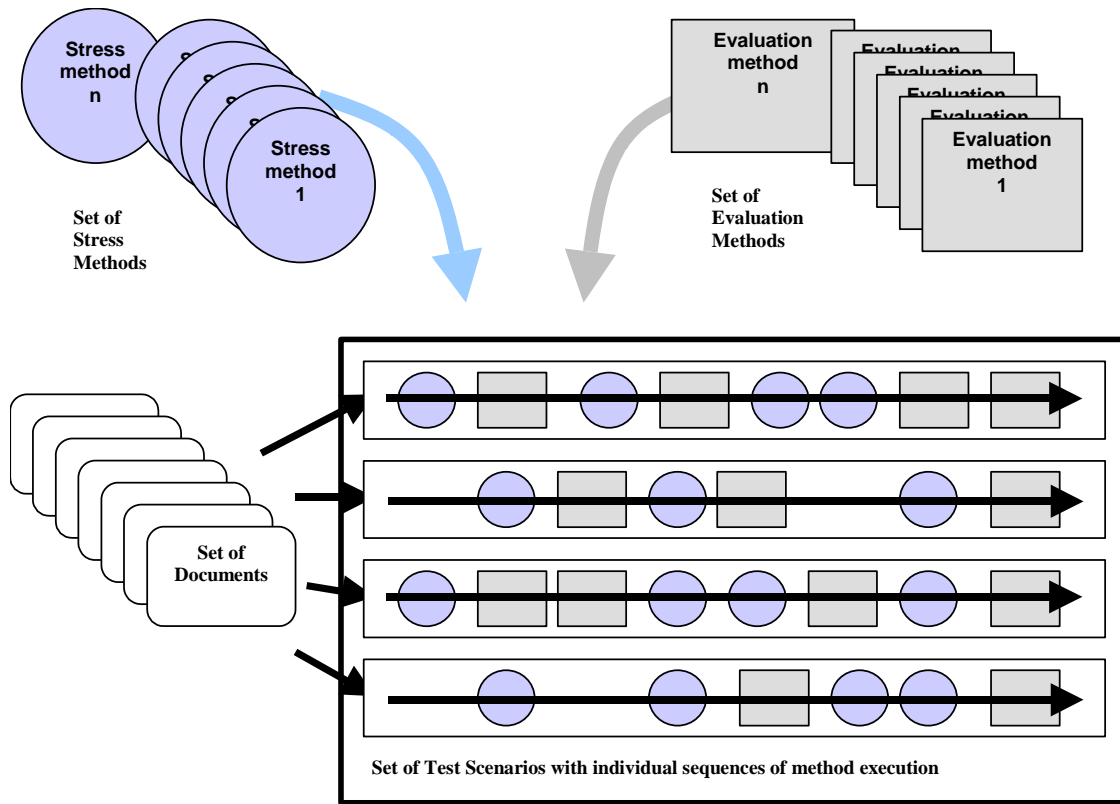

Figure 1: - Relationship Between Methods, Sequences and Test Plans

3 Guidance to the Tester

3.1 Number of Samples

References are given to a single MRP. However, multiple MRP samples may be tested simultaneously depending on the size and construction of the test apparatus.

3.2 Preparation

Test samples shall, wherever applicable, be either finished MRP's or be prepared from finished MRP's having passed the entire production process including visual personalisation with a dataset considered typical for the specific type of passport. Initialisation and personalisation of the chip may be done in an arbitrary way as long as the chip is able to support the necessary tests within the intended test sequence.

MRP's shall be conditioned in accordance with 4.1.

Test pieces shall, as necessary, be prepared from the test samples in the particular form required by the test apparatus used.

3.3 Sampling

In certain cases samples may be taken from the base material before MRP manufacture if it can be demonstrated that no significant change in the property to be tested can arise during subsequent processing. The samples used to prepare a set of test pieces shall be taken from the same batch of MRP base materials.

3.4 Storage

Any test samples or test pieces retained for reference shall be stored under the environmental conditions specified in 4.1 Default Environment.

All such samples shall be clearly cross-referenced to the test report and any relevant supplementary documentation.

4 Common Method Information

4.1 Default Environment

Unless otherwise specified, testing shall take place in an environment having a default temperature of $23\text{ }^{\circ}\text{C} \pm 3\text{ }^{\circ}\text{C}$ ($73\text{ }^{\circ}\text{F} \pm 5\text{ }^{\circ}\text{F}$) and relative humidity of 40% RH to 60% RH (ISO/IEC 10373-1).

4.2 Climatic conditions

Climatic conditions defined in the test methods given below are the conditions within the chamber. The resulting temperature in the MRP is not specified or defined in the methods.

4.3 Tolerances

Unless otherwise specified, a tolerance of $\pm 5\%$ shall be applied to the quantity values given to specify the characteristics of the test equipment (e.g. linear dimensions) and the test method procedures (e.g. test equipment adjustments).

4.4 Default MRP holder

A structure for holding the MRP while maximizing air space around the MRP during testing shall have the general construction as shown in Figure 2. There are no size or quantity limitations for the holder rack, any number of MRP positions may be used.

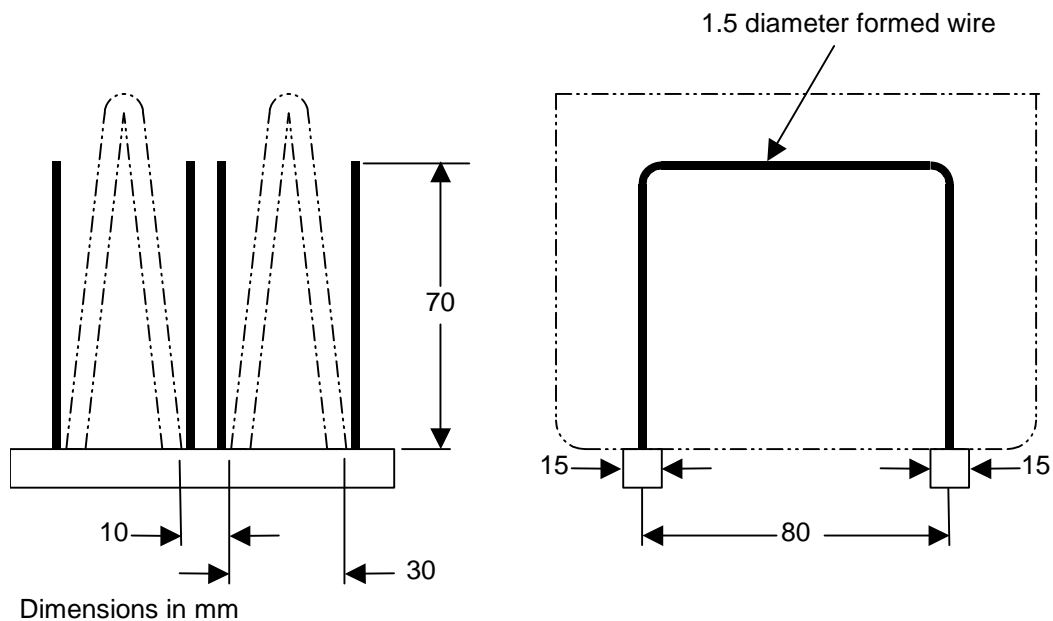

Figure 2 MRP rack

5 Stress Methods

Instructions and methods described below are designed to apply reproducible stresses to the travel document. Instructions and methods that describe how to measure the effect of these stresses are given in 6 Evaluation methods.

The fundamental philosophy behind all stress methods is to define conditions that mimic real daily use (as much as possible). In cases where the correlation between real life and the stress method is tenuous, every attempt has been made to define conditions that produce similar rates of deterioration.

5.1 Conditioning Stress Method

5.1.1 Introduction

The MRP's to be tested shall be conditioned to the test environment as described below.

5.1.2 Input Parameters

t = time of conditioning. If t is not specified, assume 24 hours.

5.1.3 Apparatus

- Default MRP holder.

5.1.4 Method

- Remove MRP from any box and protective packaging.
- Place MRP in default MRP holder with spine up. MRP shall not be forced open but may open on its own. Minimum spacing between MRP and any other MRP shall be 10 mm in all directions.
- Expose MRP to a temperature of $23\text{ °C} \pm 3\text{ °C}$ and relative humidity of 40%RH to 60%RH for at least time t.

5.2 Thermal Cycling Method

5.2.1 Introduction

This stress method subjects the MRP to cycling between two temperature extremes. This stress simulates the thermal shock the MRP could experience due to thermal expansion and contraction of each MRP component. The test is conducted over a short period of time for each stress cycle.

5.2.2 Input Parameters

n = number of cycles

5.2.3 Apparatus

- Two climate controlled chambers. Where applicable, a single fast-response climate controlled chamber may be used in place of a second test chamber.
- Default MRP holder

5.2.4 Method

- Control of relative humidity in the climate chambers is not required for this test.
- Place in a climate controlled chamber at temperature of $77\text{ °C} \pm 3\text{ °C}$ for 15 minutes.
- Transfer the MRP in the default MRP holder to a second climate controlled chamber held at a temperature of $-32\text{ °C} \pm 3\text{ °C}$ in less than 60 seconds (a transfer time of 15 seconds is recommended). The position of the MRP in the holder should not be modified during the transfer process.
- Subject the MRP to a temperature of $-32\text{ °C} \pm 3\text{ °C}$ for 15 minutes.
- Repeat the process for n cycles as depicted in Figure 3.
- At the end of the cycling process remove MRP and return to the default environment. Leave MRP in holder and condition according to 4.1.

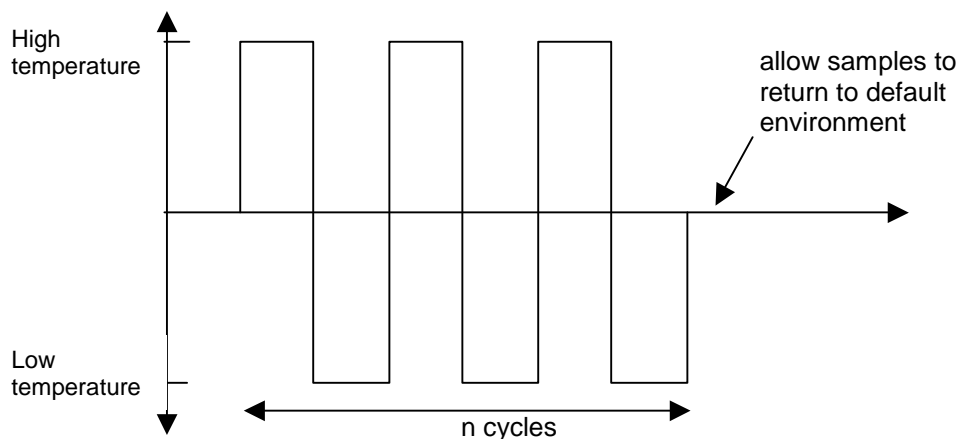

Figure 3: Thermal Cycling

5.3 Storage Temperature Stress Method

5.3.1 Introduction

This stress method applies high or low temperature and humidity to the document for specified amounts of time. This stress simulates a document's exposure to various storage conditions. The purpose of the test is to demonstrate the resistance of MRP construction to such conditions in principle.

The test refers to temperature stability in Doc 9303: "2.4 Temperature stability. The MRP shall remain machine readable at operating temperatures ranging from -10°C to $+50^{\circ}\text{C}$ (14°F to 122°F). The MRP should not lose its reliability after being stored or exposed at temperatures ranging from -35°C to $+80^{\circ}\text{C}$ (-31°F to 176°F)."

Note that extremes of temperature may affect various security features, especially inks. Changes in these features shall not be considered a failure unless they render the document unrecognisable as belonging to the bearer.

5.3.2 Input Parameters

T = temperature at which the passport is stored

H = relative humidity for storage

5.3.3 Apparatus

- Climate controlled chamber.
- Default MRP holder

5.3.4 Method

- Place MRP in climate controlled chamber at temperature $T \pm 3^{\circ}\text{C}$ and H Relative Humidity for 168 hours.
- Remove MRP

5.4 Operational Temperature Stress Method

5.4.1 Introduction

This stress method applies high or low temperature and humidity to the document for specified amounts of time. This stress simulates a document's exposure to various climatic conditions. The purpose of the test is to demonstrate the resistance of MRP construction to such conditions in principle.

The test refers to temperature stability in Doc 9303: "2.4 Temperature stability. The MRP shall remain machine readable at operating temperatures ranging from -10°C to $+50^{\circ}\text{C}$ (14°F to 122°F). The MRP should not lose its reliability after being stored or exposed at temperatures ranging from -35°C to $+80^{\circ}\text{C}$ (-31°F to 176°F)."

Note that extremes of temperature may affect various security features, especially inks. Changes in these features shall not be considered a failure unless they render the document unrecognisable as belonging to the bearer.

5.4.2 Input Parameters

T = temperature at which the passport is expected to operate

5.4.3 Apparatus

- Climate controlled chamber.
- Default MRP holder

5.4.4 Method

- Place MRP in climate controlled chamber at temperature $T \pm 3^{\circ}\text{C}$ for 1 hour.
- Evaluate the MRP within the climate chamber.

5.5 Impact Stress Method

5.5.1 Introduction

This stress method applies a certain forced impact to the sample to simulate stamping of the document at a border control point.

5.5.2 Input Parameters

S = sheet to be affected by impact. Note, as only visa pages will be impacted, sheet S may not be impacted directly.

5.5.3 Output Parameters

None

5.5.4 Apparatus

- Stamp:

The face of the stamp is a flat solid surface, steel or equivalent, with a diameter 29 mm.

Concentric circles are etched into the surface. The profile of the grooves is rectangular, with a minimum groove depth 0.3 mm. The width of the grooves is $1 \text{ mm} \pm 0.1 \text{ mm}$, and the nominal distance between grooves is 1.5 mm.

The nominal diameter of the central circular groove is 1 mm.

The accumulated tolerances of groove distances is $\pm 0.5 \text{ mm}$.

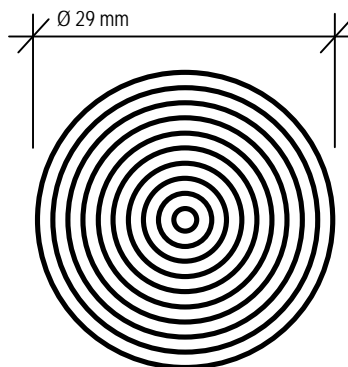

Figure 4: Impact Pattern Resulting from Specified Stamp

- The stamp/weight may be constructed as one of:
 - Single-piece stamp of mass M
 - Stamp that is placed on document and then struck by a weight of mass M.
- Flat surface made of steel at least 12 mm thick with a 2mm rubber blanket
- The rubber blanket shall have a Shore D value of 50.
- Suitable guiding for stamp to maintain stamping face parallel to MRP surface at the point of impact.
- Holder for retaining pages of the MRP against the flat surface during testing.

- Description of stamp parameters:

H = nominal height (mm) from which an impact stamp is dropped onto the document or weight is dropped onto the stamp, thereby defining an impact velocity according to the formula for acceleration of inert bodies under earth gravitation.

H shall be between 0.05 m and 0.20 m

M = weight (kg) of the impact stamp

D = displacement between two impacts

The product $P = H \cdot M$ shall have a value of 0.02 kg·m.

If the apparatus is composed of a stamp that is impacted by a separate weight, the weight shall have mass M, and be dropped from a height H above the stamp. The mass of the stamp is not considered.

5.5.5 Method

- Locate the sheet S.
- Locate the nearest visa page that could require stamping and turn this over on top of the sheet under test. Depending on location, it is possible that there could be several sheets between the sheet S and the nearest visa page.
- Open MRP to 180 degrees and place on flat hard surface covered with a rubber coating so the outer cover is directly against the flat surface.
- Drop impact stamp of mass M from a height H at each of the locations as shown in Figure 5. Move from first to last location progressing from left to right and from top to bottom.
- If there are visa pages that could require stamping on the opposite side of the sheet under test, repeat the above process on the other side, but using a different MRP.

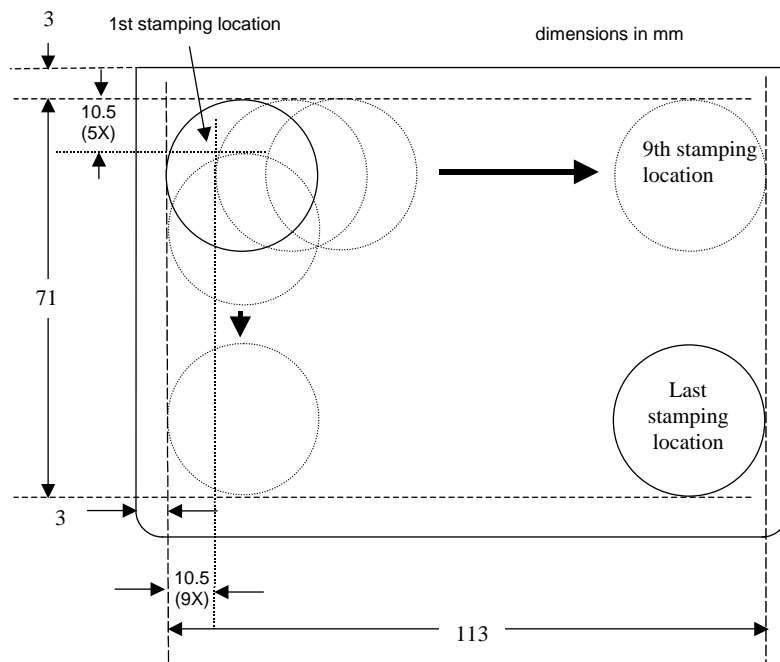

Figure 5: Impact stamp locations

5.5.6 Alternate Method

- If the fragile area is obvious it is acceptable to exclude drops that do not impact this obvious area.

5.6 Book Bend Stress Method (Back Pocket)

5.6.1 Introduction

This test simulates on the stresses of sitting on a MRP, This method applies a force to the MRP and forces it to bend around a curved surface. The resulting stresses acting on the MRP are a combination of compression and bending stresses.

5.6.2 Input Parameters

n = number of cycles to apply force

5.6.3 Output Parameters

None

5.6.4 Apparatus

- A test apparatus to load the MRP in a manner consistent with Figure 6 below.
- An anvil with spherical impact area of radius $r = 150$ mm.
- A cushion having elastic properties equivalent to an air cushion inflated to a pressure of 30 kPa, or to foam having density of 40-50 g/l and hardness of 20-30 kg/cm² as defined in ISO 2439. The minimum thickness of the cushion is 0.1 m. The minimum dimension, in any direction, of the cushion surface on which the sample is placed shall be larger than 0.2 m and shall be larger than the anvil.
- Notes:
The test results do not depend on the exact properties of the cushion as long as (a) its resistance to the force exerted by the sample under the anvil is sufficient to so that the force is not deviated from the sample (i.e. the activated anvil shall not touch the cushion directly as long as the bending of the sample is not entirely following the anvil shape),
(b) its elasticity is sufficient to follow the anvil shape without irregular deformations, and
(c) its resistance to the exerted pressure is not subject to local deviations or irregularities.

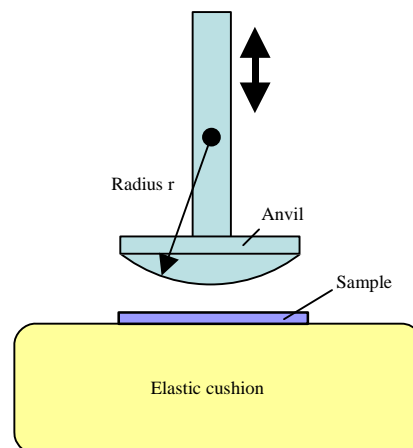

Figure 6: Schematic of the test apparatus to load the MRP in the Back Pocket Bending Method

5.6.5 Method

- Place and center the MRP with respect to the cushion and the spherical anvil.
- Secure the MRP on the test machine so that the centered placement can be maintained during testing. A flexible support pocket constructed from fabric such as denim may be used.

- Press the spherical anvil into the MRP and cushion support to a maximum force of 350 N. Maintain the applied force of 350 N for 5 s.
- Lift the spherical anvil so that it does not touch the MRP or cushion. The net external force acting on the MRP shall be less than 0.2 N.
- Repeat the loading and unloading process for a total of n times.
- Turn the MRP over and repeat the loading and unloading process n times.

5.7 Dynamic Bend Stress Method

5.7.1 Introduction

The purpose of this test is to determine the bending fatigue resistance of the booklet construction to fully reversed loading. This method differs from the back pocket stress method by avoiding directly applied pressure. This method accelerates fatigue due to imposed bending, especially in the area of the antenna and associated connections if present.

5.7.2 Input Parameters

n = Number of bending cycles with the MRP

O = orientation of book in the bender

5.7.3 Output Parameters

None

5.7.4 Apparatus

- Dynamic flexion machine as illustrated below.

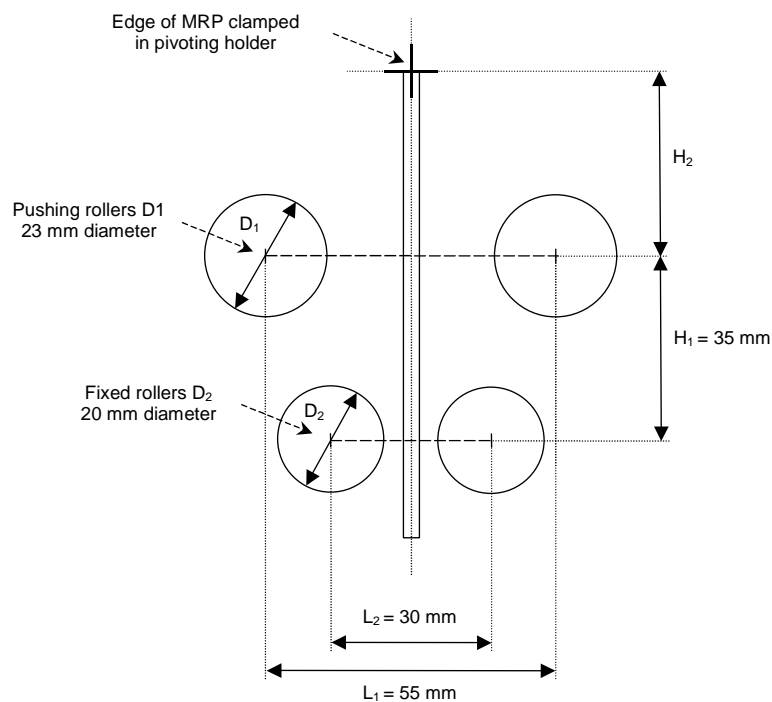

Figure 7: Apparatus to impose cyclic motion

- The pushing rollers shall be set to ensure that the centreline deflection of the MRP is equal on each segment of the stroke.
- The distance H_2 between the clamped edge of the MRP and the pushing rollers on center is adjustable between 40 and 58 mm.
- Pushing rollers and fixed rollers are separated by 35 mm (H_1) on center.
- Pushing rollers have an outer diameter D_1 of 23 mm and are separated by 55 mm (L_1) on center.
- Fixed rotating rollers are separated by a distance of 30 mm (L_2) on center and have an outer diameter D_2 of 20 mm.

5.7.5 Calibration of movement Method

- Taking into account, the specified orientation, O, the MRP shall be clamped at one extremity and allowed to freely move at the opposite edge.
- H_2 should be adjusted depending on the orientation of the book

Orientation (O)	H_2
Spine clamped	40 mm
Top clamped	58 mm

- Move the pushing rollers so that they just push the passport up against the fixed rollers without bending the passport as illustrated below. The amount of roller movement is b_0 and is called the initial position.

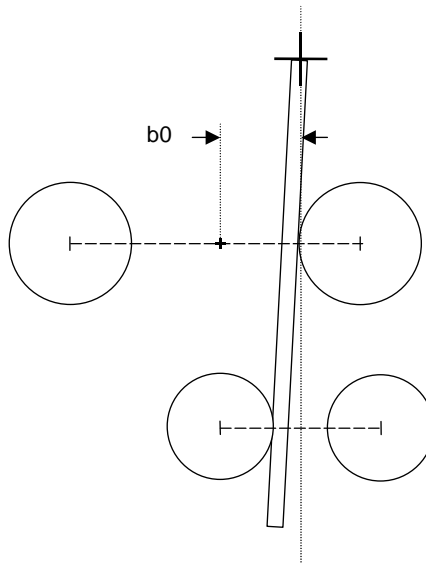

Figure 8: Initial position of Pushing Rollers

- Allow the pushing rollers to move freely, however set the maximum travel of the pushing rollers to $b_0 + 20$ mm.
- Apply a force of 40 N in the direction of the bold arrow in Figure 9 for 1 minute.

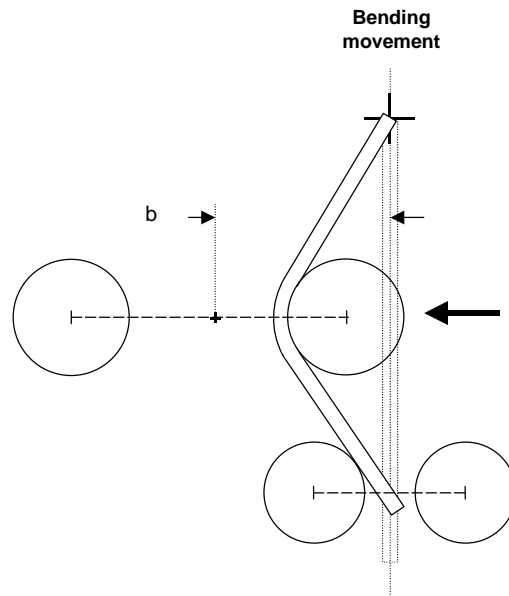

Figure 9: Bending movement

- Measure the amount of travel of the pushing rollers. If the maximum travel is reached with a force of less than 40 N then the travel to be used for the test is $b = b_0 + 20$ mm; otherwise measure the amount of travel of the pushing rollers, b , as shown in the figure above.
- Remove 40 N load.
- Note, alternate equipment may be used for calibration.

5.7.6 Method

- Set the travel of the pushing rollers to $\pm b$ as measured above.
- Flex the book n times at 0.5 Hz. One cycle is a one deflection in each direction.

5.8 Torsion Stress Method

5.8.1 Introduction

The purpose of this test is to determine adverse mechanical or functional effects in the MRP arising from torsional fatigue. This method differs from the back pocket stress method by applying only torsional stresses to the MRP.

5.8.2 Input parameters

n = Number of torsion cycles

5.8.3 Output parameters

None

5.8.4 Apparatus

- The test apparatus shall impose torsional motion in a manner consistent with Figure 10 shown below.

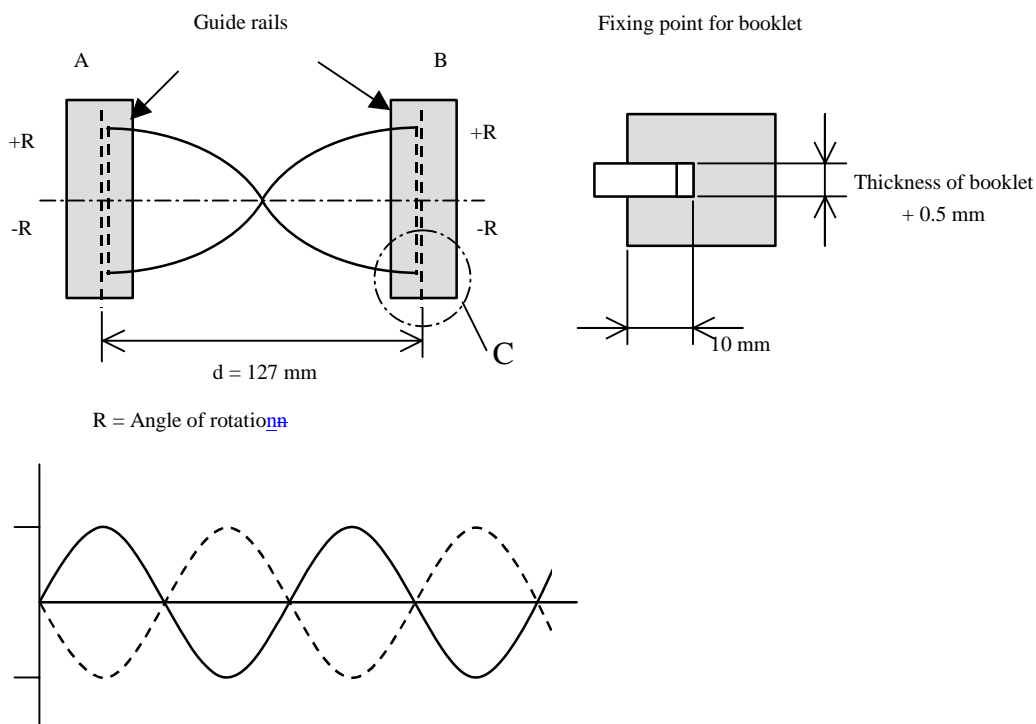

Figure 10: Schematic of the apparatus and the associated motion for torsion

5.8.5 Calibration

- Adjust separation of guide rails to thickness of book plus a maximum of 1 mm.
- Place MRP in test apparatus
- Set maximum travel of holders to 15 degrees.
- Apply a torque of 0.3 N-m for 1 minute.
- Measure amount of travel and reset maximum travel, R , of holder to amount measured.

- Remove 0.3 N-m torque load.
- Note, alternate equipment may be used for calibration.

5.8.6 Method

- Place MRP in test apparatus
- One cycle consists of the following continuous steps (movement is not stopped at the 0 position except at that start and end of the test):
 - Start from a point where both holder A and holder B are at angle 0
 - Rotate holder A to angle +R, while simultaneously rotating holder B to angle -R.
 - Rotate holder A to angle -R, while simultaneously rotating holder B to angle +R.
 - Rotate holder A to angle 0, while simultaneously rotating holder B to angle 0.
- Operate the test apparatus at a speed of 0.5 Hz for n cycles.

5.9 Sheet Turning Stress Method

5.9.1 Introduction

The purpose of the test is to determine the folding resistance of a sheet of a machine readable passport (MRP) at the spine.

5.9.2 Input Parameters

P = Sheet under test

n = Number of cycles

5.9.3 Output Parameters

None

5.9.4 Apparatus

- Fixture for clamping the fixed sheet or MRP
- Arm for rotation of sheet or MRP
- Device to apply force to sheet or MRP being tested.
- Note that no constraints are placed on machine design, including which clamp is fixed, which clamp moves, and which clamp force the force is applied to.
- Note also that the apparatus should prevent bending of the booklet in any other place than the axis of the booklet spine.

5.9.5 Method

- The entire book except the sheet to be tested is folded back and held in a clamp. The sheet to be tested is held in another clamp allowing for the rotation of the sheet or MRP under test around the spine between the defined angle positions:

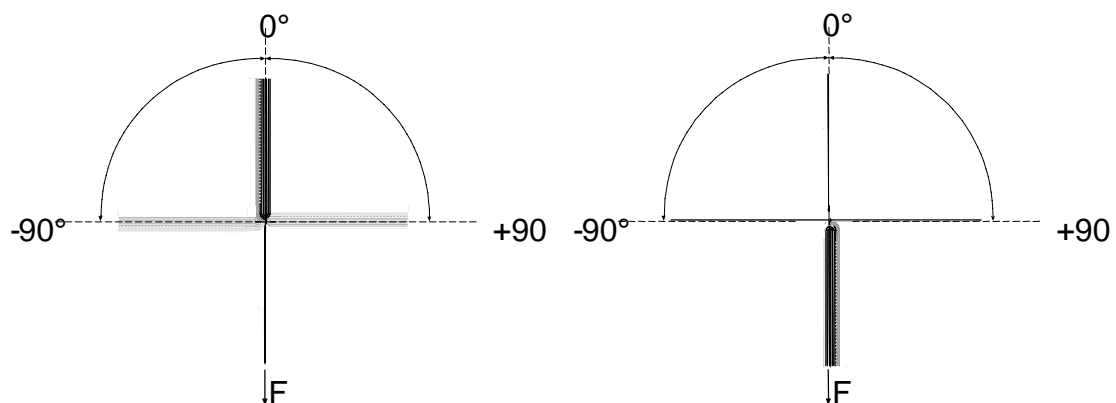

Figure 11: Sheet Bending Illustration

- Bending Parameters
 - Bending frequency: $f = 0.5 \text{ Hz}$
 - Bending angle: $a = \pm 90^\circ$
 - Tensile force: $F = 1 \text{ N/cm} \pm 25\%$ (force per length of sheet)

5.10 Sheet Pull Stress Method

5.10.1 Introduction

The purpose of the test is to determine the tearing resistance of the booklet pages and the sewing part during the usage of a machine readable passport (MRP).

5.10.2 Input Parameters

P = Sheet under test

5.10.3 Output Parameters

S = Maximum tearing strength in N/cm

5.10.4 Apparatus

- Clamp to hold MRP in a fixed position, minimum width of clamping area 130 mm
- Movable clamp for pulling on the page under test, minimum width of clamping area 130 mm

5.10.5 Method

- Cut the opposite sheet of the one under test. The cutting distance from the spine should be of 10 mm.
- Place all the other sheets including cover in the fixed clamp of the apparatus.
- The fixed clamp shall be set at a distance from the spine so that it does not clamp any portion of the sheet under test.
- Apply a force of 60 N at a maximum velocity of 5 mm/s.

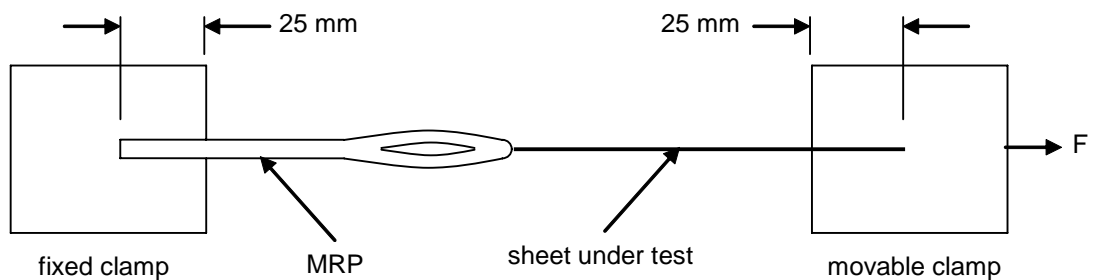

Figure 12: Sheet Pull Apparatus

5.11 Abrasion Stress Method

5.11.1 Introduction

The purpose of this test is to determine the effect of a specified mechanical abrasion to the Passport Data Page of an ICAO-compliant document. The main purpose is to test the machine-readable zone (MRZ) but the test might also be used for the Visual Inspection Zone (VIZ) or visa entries (sticker) of the passport. In order to perform this test, the datapage (visa page) shall be personalized.

The abrasive material to be used should be the material of the facing page.

5.11.2 Input Parameters

n = number of test cycles (double strokes)

5.11.3 Output Parameters

None

5.11.4 Apparatus

test load $L = 14000 \pm 5 \% N/m^2$

length (or diameter) of test load $D = 15 \text{ mm}$ (width shall cover MRZ)

test speed $v = \text{between } 2.5 \text{ and } 25 \text{ cm/s}$

- The abrasive material has to be attached to the test load without protruding beyond the edge of the passport. If increased adhesion is required a double sided adhesive tape can be used.
- Test Load Movement: -The abrasion axis is parallel to the MRZ of the MRP. The amplitude of the test load movement shall cover at least 20 mm. Test equipment may move/rotate the test load during the test between cycles.

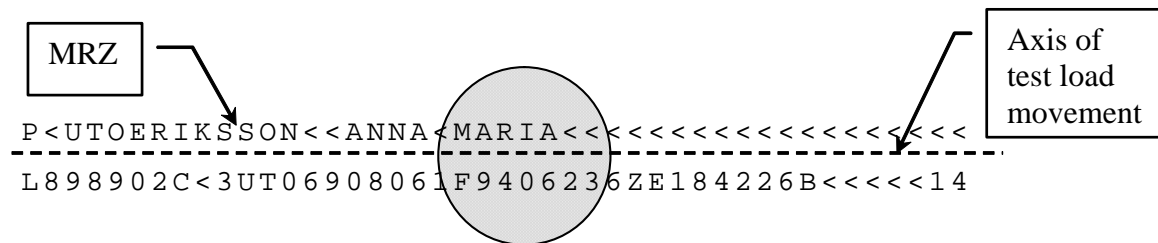

Figure 13: Illustration of the Abrasion Test

5.11.5 Method

- Fix the Passport Data Page on a level rigid plate (i.e. sample carrier of the test equipment). Apply the test load and start the apparatus at specified speed and amplitude for the specified number of test cycles.
- Alternative equipment may be used as long as it provides equivalent results (e.g. Taber method from ISO 9352 using CS10F wheel).

5.12 Pen Stress Method

5.12.1 Introduction

The purpose of the test is to simulate writing over the PIC with a ball point pen simulating manual entries on visa pages. It is felt that depending on the construction of the passport, a pen might damage components of the passport (IC, inlay or paper).

The page to be written on shall be one that is normally written on and shall provide maximum stress to the chip (if present). In the case where it is possible to write on pages on both sides of the chip sheet, separate MRP's should be evaluated.

Note, this method may not be suitable when devices like rivets are used. I.e. the pen may become damaged or stuck if features protrude from the page under test.

5.12.2 Input parameters

n = number of cycles

P = page to test

5.12.3 Output parameters

None

5.12.4 Apparatus

- Pen with ball point of diameter 0.7 mm compliant with ISO 12757-2.
- Pen positioning apparatus capable of pen movement in X and Y direction over the area shown in Figure 14. Pen shall be held at an angle of 90 degrees to the page under test.

5.12.5 Method

- Choose a Page P to write on. It shall be a Page that is normally written on and shall provide maximum stress to the chip. In the case where it is possible to write on pages on both sides of the chip page, both sides will be tested.
- Clamp MRP in suitable holding fixture so pages do not move during testing.
- Apply a load to pen of 250 g downward toward pages under test.
- Apply a series of strokes, each in the form of a double line (movement back and forth along the same straight line and across the dimension of the sample) and at a nominal distance of 1.5 mm between lines.

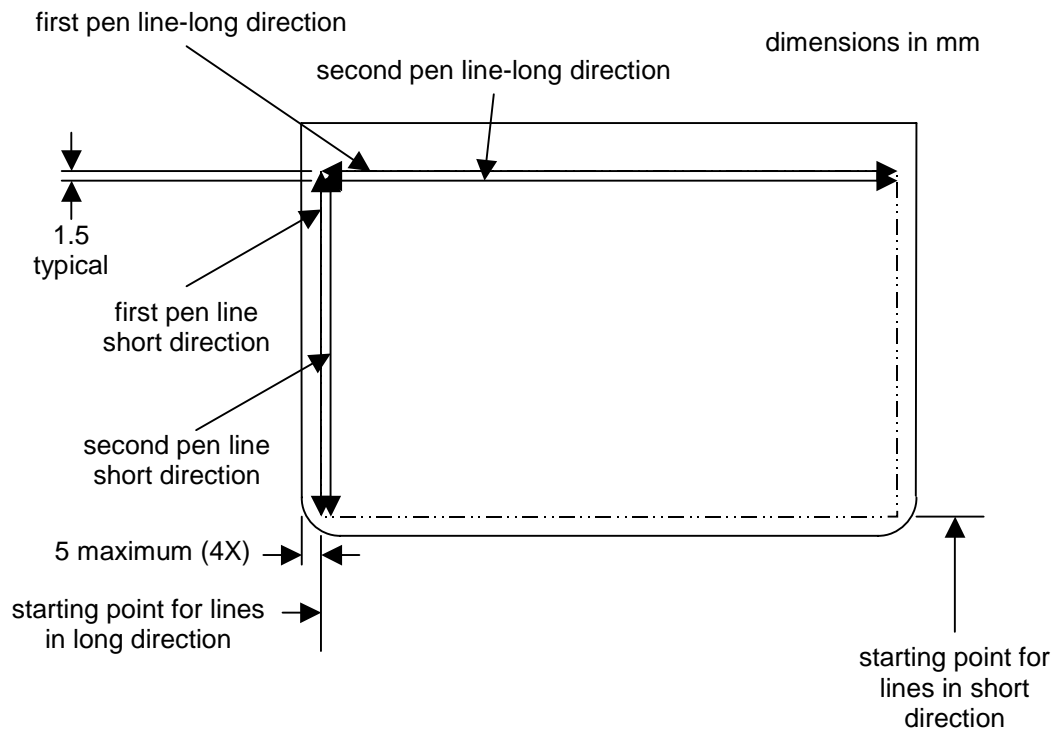

Figure 14: Pen stress test area

- Move pen with a maximum speed of 150 mm/sec from left to right and back again on the same line as shown in Figure 14 for lines in the long direction.
- When the pen has returned to the starting point, move to the next line as shown. It is not necessary to lift the pen when moving from one line location to the next.
- After completing the last line in the long direction, begin to make lines in the short direction.
- Move pen with a maximum speed of 150 mm/sec from bottom to top and back again on the same line as shown in Figure 14 for lines in the short direction.
- When the pen has returned to the starting point, move to the next line as shown. It is not necessary to lift the pen when moving from one line location to the next.
- Replace pen as soon as ink is exhausted, lines shall not be made with no ink.
- Outer margin of 5 mm from the edge of the page under test may be disregarded. This margin may be used to stabilize the page under test by e.g. clamping or taping it to the support.
- The surface coverage may be reached in a single run or by consecutive runs covering sub-areas of the page under test.
- Repeat the sequence n times.
- If critical areas are obvious, the pen test may be performed only over those areas.

5.13 Resistance to chemicals Evaluation Method

5.13.1 Introduction

The purpose of this test is to determine any adverse effects of a range of chemical contaminants on an MRP test sample. It is possible that the document may not be useable for travel after this test, but it is expected that the book shall be identifiable as belonging to the bearer.

Certain security features incorporated into MRP's are designed to react to reagents in order to show that tampering has taken place. The action of these security features under the influence of the reagents shall not constitute a failure.

5.13.2 Input Parameters

None

5.13.3 Output Parameters

None

5.13.4 Apparatus

- MRP holder
- Solutions as required

5.13.5 Short Term Contamination Test

5.13.5.1 Short Term Reagents (list provided here for information only, defined in ISO/IEC 10373-1)

- a) 5% by mass aqueous solution of sodium chloride (NaCl, 98% minimum assay);
- b) 5% by mass aqueous solution of acetic acid (CH₃COOH, 99% minimum assay);
- c) 5% by mass aqueous solution of sodium carbonate (Na₂CO₃, 99% minimum assay);
- d) 60% by mass aqueous solution of ethyl alcohol (CH₃CH₂OH, 93% minimum assay);
- e) 10% by mass aqueous solution of sucrose (C₁₂H₂₂O₁₁, 98% minimum assay);
- f) Fuel B (according to ISO 1817);
- g) 50% by mass aqueous solution of ethylene glycol (HOCH₂CH₂OH, 98% minimum assay).

5.13.5.2 Short Term Contamination Method

- Use solutions as defined in ISO/IEC 10373-1.
- Use a different sample MRP for each solution.
- Prior to immersion in the test solution, fan the pages of the MRP such that the sheets of the MRP are exposed.
- Standing the MRP upright (spine is in a vertical orientation), submerge the MRP for 60 seconds in one of the solutions listed above. The solutions shall be kept at a temperature between 20 °C and 25 °C.
- Remove MRP from solution and place in default MRP holder for 24 hours at default temperature and humidity conditions. For those samples immersed in organic solvents (including fuel), this procedure should be performed within the confines of a fume hood.

5.13.6 Long Term Contamination Test

5.13.6.1 Long Term Reagents (list provided here for information only, defined in ISO/IEC 10373-1)

- a) salt mist;

- b) artificial perspiration (both solutions shall be prepared in accordance with ISO 105-E04:1994):
(i) alkaline solution; (ii) acid solution.

5.13.6.2 *Method for Salt Mist*

- Use neutral solution as defined in ISO/IEC 10373-1.
- Use a different sample MRP for each test.
- For the salt mist exposure, mount the sample MRP vertically in a cabinet in accordance with ISO 9227:1990 for 24 hours.
- Remove MRP from solution and place in default MRP holder for 24 hours at default temperature and humidity conditions.

5.13.6.3 *Method for Synthetic Perspiration*

- The filter paper shall be compliant with ASTM E 832. Any Type I filter paper for qualitative analysis may be selected.
- Soak filter paper in the artificial perspiration solution. Allow excess liquid to drain for 10 seconds then place it on a flat non-absorbent surface (glass plate) to stabilise for 1 minute.
- Wrap the sample MRP in the wetted filter paper and place this in a sealed plastic bag in an environment kept between 20 °C and 25 °C. The plastic bag shall be placed between flat plates with a 5 kg weight positioned on top.
- Leave the sample in this environment for 24 hours.
- Remove MRP from solution and place in default MRP holder for 24 hours at default temperature and humidity conditions.

5.14 Artificial Daylight Exposure Stress Method

5.14.1 Introduction

This test is derived from ISO 105-B02 and exposes the sample to illumination from an artificial light source that represents natural daylight in the visible and near UV (UV A) spectral region. The aim of this test is to assess the resistance of the MRP to fading.

Note: The blue wool reference numbers refer to those preferred in Europe (1-8) and not those preferred in the US (L2-L9)

Note that this method is difficult to apply to ordinary security printing backgrounds due to the fine structure of the linework. It is acceptable to print samples using test patterns for each ink used in production to facilitate this test.

5.14.2 Input Parameters

P = page to expose

S = blue wool scale to measure exposure

5.14.3 Output Parameters

None

5.14.4 Apparatus

- An air-cooled xenon arc lamp apparatus with a well-ventilated exposure chamber and a xenon arc lamp of correlated colour temperature 5500 K – 6500 K shall be used. A light filter (glass filter) placed between light source and samples shall cut all radiation with wavelengths smaller than 310 nm. A heat filter placed between light source and samples shall be used in order to reduce IR radiation contained in the xenon arc spectrum.

5.14.5 Method

- Cut a sample from the MRP to required size for the test machine and place an opaque cover over a portion of the sample (for comparison purposes)
- Prepare the appropriate blue wool reference in the same way. Strips cut from the blue wool references 1 to S shall be used.
- Place samples together with the blue wool reference set in the accelerated daylight test apparatus and expose to artificial daylight according to Method 2 (ref. ISO 105 B-02) until the exposed part of the blue wool reference S has faded to the equivalent of gray scale 4

5.15 X-Ray Stress Method

5.15.1 Introduction

The purpose of this test is to determine any adverse effects to the MRP by X-rays levels that might be encountered during border control screening. The MRP shall comply with the requirement in ISO/IEC 7816-1 when tested in accordance with ISO/IEC 10373-1.

5.15.2 Input parameter

None

5.15.3 Output Parameter

None

5.15.4 Apparatus

- Use apparatus defined by ISO/IEC 10373-3 for X-rays.

5.15.5 Method

- Follow the procedure in ISO/IEC 7816-1 for x-ray testing. (Substitute MRP for card, wherever it appears in the procedure in ISO/IEC 7816-1).

6 Evaluation methods

Evaluation methods are instructions describing how to measure specific attributes of the passport. Wherever applicable, the output of the evaluation method should be a numerical value that can be compared against a pass/fail criterion.

6.1 Functional PIC Evaluation Method

6.1.1 Introduction

This method evaluates the function of the Proximity Integrated Circuit (PIC). The method determines that chip is still sane and that it operates within normal and reasonable conditions. There is always a tradeoff between the execution time of this method and the completeness of the test.

If the MRP does not contain a chip, this evaluation method returns a Pass result.

6.1.2 Input Parameters

None

6.1.3 Output Parameters

R = Pass/Fail

6.1.4 Apparatus

- Commercial PIC reader.

6.1.5 Method

- Evaluate the PIC as per reference [9], RF Protocol and Application Test Standard for e-Passport – Part 2, WG3TF4_N0163, Version 0.9, 2006-02-10, section C.2.

6.2 Physical Damage Evaluation Method

6.2.1 Introduction

The intent of this method is to verify that the passport is (still) suitable for use as a travel document. To pass the evaluation method, the document shall be intact, and shall still be machine readable. Some security features may be degraded or altered, however, the evaluation of these features may be subjective and specific to individual passports and are therefore outside the scope of this method.

6.2.2 Input Parameters

None

6.2.3 Output Parameters

R = Pass/Fail

6.2.4 Apparatus

None

6.2.5 Method

Physical damage and related acceptability levels are best evaluated by comparing the sample(s) under test to a set of evaluation samples that is considered to be just at the limit of acceptability. However as the authors need to put something prescriptive on paper, the following limits should be placed on a MRP for it to be useable. Future versions of this document will hopefully contain a more complete list of requirements.

- The picture shall be reconizeable.
- Written information shall be legible, with no missing letters or words.
- The MRZ shall be machine readable.
- The MRP shall be Intact – no pages shall be separated.
- Opening the MRP to the datapage (180 degrees) shall not incur any further damage.
- opening the MRP to a visa page (180 degrees) shall not incur any further damage.
- The PIC containing part (Cover, Data Page, Special visa page) does not allow direct access to the chip or the antenna.
- No part of the datapage shall be missing.
- For datapages, more than 90% of the binding shall be intact.
- For other pages, more than 50% of the binding shall be intact.
- At least 50% of the hot-stamp on the cover shall be intact.
- Any holes in any sheets shall be less than 2mm in diameter.
- Areas of delamination along the edges shall be less than 3 mm deep, and 3 mm in length. Delaminations within the sheet shall be less than 3 mm in length.

6.3 Peel Strength Evaluation Method

6.3.1 Introduction

The purpose of this test is to measure the peel strength between different layers used in passport constructions according to ISO/IEC 10373-1/5.3.

If the sheet to be evaluated is composed of multiple layers, the peel strength evaluation should be conducted on all layers. A separate document should be used for each layer so that a consistent number of strips will be cut from the sheet.

6.3.2 Input Parameters

P = sheet to perform test on

6.3.3 Output Parameters

F = strength (N/mm)

6.3.4 Apparatus

- Use apparatus defined in ISO/IEC 10373-1 Peel test method. References to “card” shall mean “sheet” for this test. If a stabilizing plate is required, a suitable size would be 95 mm x 130 mm.

6.3.5 Method

- Remove the sheet to be tested from the MRP
- Follow the method for peel strength measurements as outlined in ISO/IEC 10373-1, Peel test method, except for preconditioning and the direction and quantity of sample sections.
- Following Figure 15, cut the sample, or score through the layer, to produce sections of width 10.0 mm \pm 0.2 mm. The top reference edge is the edge closest to the spine

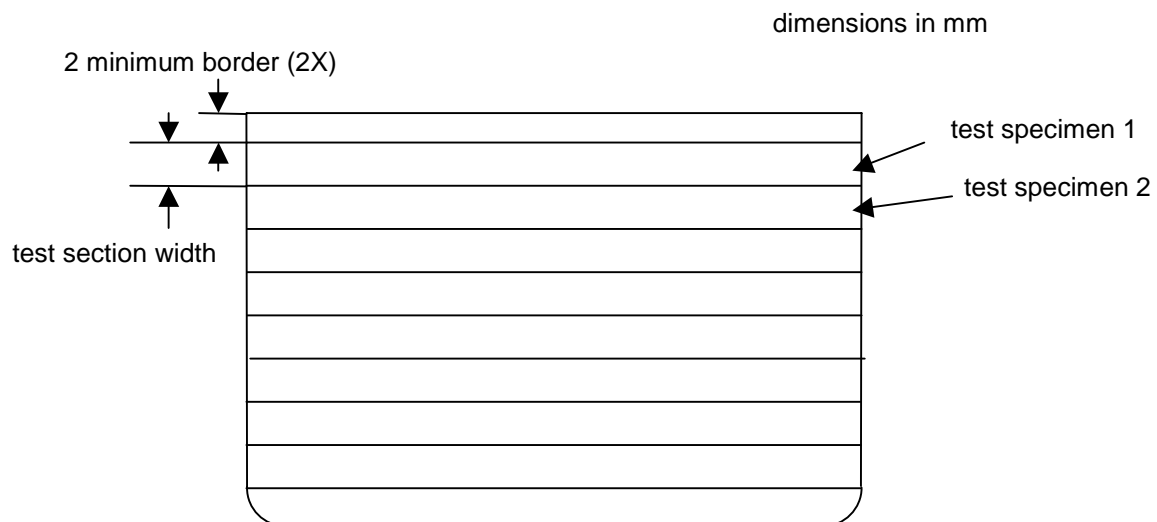

- Figure 15: Peel test sample preparation

6.4 Colour Fastness Evaluation Method

6.4.1 Introduction

This evaluation method determines the change in appearance of the sample following exposure to artificial daylight. This evaluation method relies on the sample being subjected to 5.14 Artificial Daylight Exposure Stress Method.

6.4.2 Input Parameters

P = Page to evaluate

6.4.3 Output Parameters

R = Pass/Fail

6.4.4 Apparatus

None

6.4.5 Method

- Colour fastness evaluation derived from ISO 105-B02.
- The evaluation procedure is as follows:
- Visually evaluate fading or colour changes. For this purpose samples shall be illuminated by a D65 light source.
- Compare the contrast between exposed and unexposed sample with the contrast of gray scale 4.
- If the sample contrast is higher then the test result is Fail. If the sample contrast is less or equal then the test result is Pass.

6.5 Datapage Warpage Evaluation Method

6.5.1 Introduction

The purpose of this test is to measure the extent of warpage in the MRP. The amount of warping in a MRP is important to ensure contactless IC and MRZ chip readability.

6.5.2 Input Parameters

None

6.5.3 Output Parameters

R = Pass/Fail

6.5.4 Apparatus:

- A level rigid surface whose roughness is not greater than $3.2\ \mu\text{m}$ in accordance with ISO 1302.
- A flattening plate weighing 200 g measuring 88 mm x 125 mm.
- A height gauge or similar measuring device with a minimum accuracy of 0.1 mm.

6.5.5 Method

- Open the MRP and place only the datapage and cover on a level rigid surface, with the nearest visa page positioned 3 mm from the edge of the level rigid plate as shown in Figure 16.
- Apply and centre the 200 g flattening plate directly on top of the pages. Align long edge of flattening plate with edge of rigid surface.
- Using a height gauge, measure the maximum combined thickness of the combined pages. Record this value as $D1$.
- Measure the maximum total combined thickness of the pages that were measured for warpage in Figure 16. Record this value as $D2$.
- The result R is Pass if $D1 - D2$ is less than or equal to 3 mm.

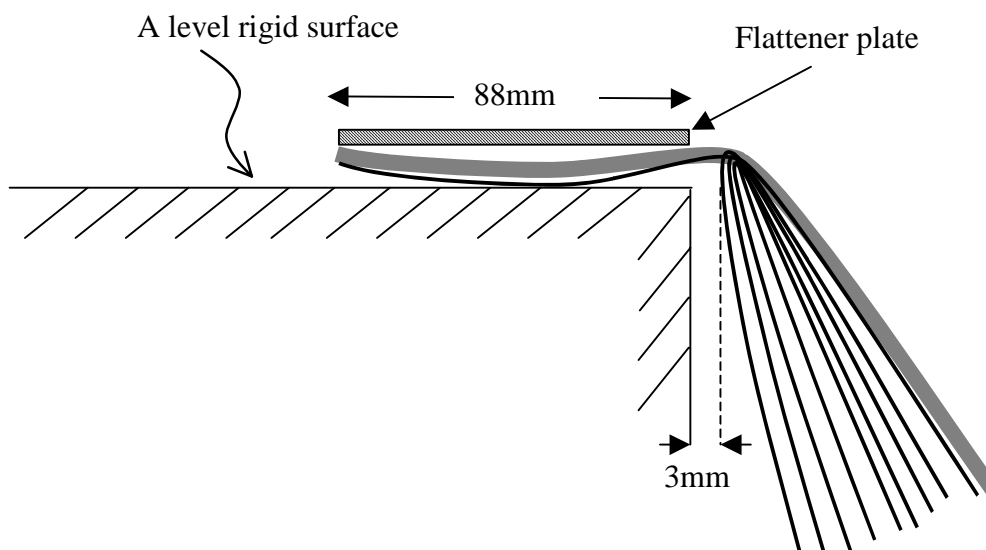

Figure 16: Datapage Warpage Measuring Arrangement

6.6 Book Warpage Evaluation Method

6.6.1 Introduction

The purpose of this test is to measure the extent of warpage in the MRP. The amount of warping in the MRP is important to ensure contactless IC chip readability. This method is similar to the Datapage Warpage Evaluation Method but measures the amount of warpage with the MRP in the closed position.

6.6.2 Input Parameters

None

6.6.3 Output Parameters

R = Pass/Fail

6.6.4 Apparatus:

- A level rigid surface whose roughness is not greater than $3.2\ \mu\text{m}$ in accordance with ISO 1302.
- A flattening plate weighing 200 g measuring 88 mm x 125 mm.
- A height gauge or similar measuring device with a minimum accuracy of 0.1 mm.

6.6.5 Method

- Measure the maximum thickness of the MRP. Record this value as $D1$.
- Place the closed MRP on a level rigid plate.
- Center the 200 g flattening plate directly on top of the MRP.
- Using a height gauge, measure the maximum height of the MRP. Record this value as $D2$.
- The result R is Pass if $D2 - D1$ is less than or equal to 10 mm.

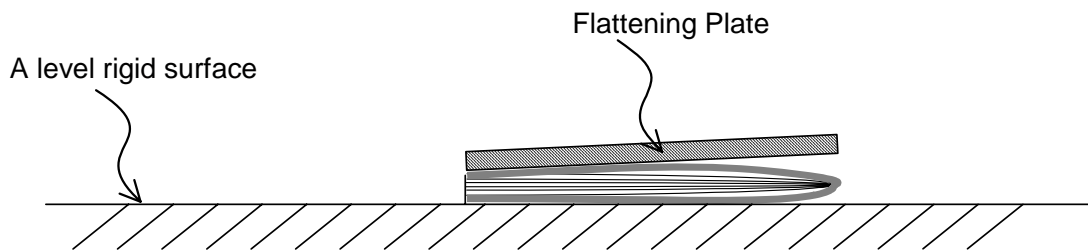

Figure 17: Book Warpage Measuring Arrangement

7 Test sequences

7.1 General

Sequences are defined to specify the order in which stress methods and evaluation methods are to be performed in order to execute a specific test.

7.2 Instructions for using the Sequence Table

The headings of a sequence table is reproduced below:

Step No.	S/E	Method	Parameters	Output Parameters Measured	Pass/Fail Criteria

This table defines the order of the methods to be performed. The content of each column is defined below.

Step No.	The reference number for the step within the sequence. The order of the methods within the sequence table determines the order in which the methods are to be executed – not the step number.
S/E	Indicates whether the method is a Stress method or an Evaluation method.
Method	The name of the method to be performed
Parameters	Defines the values of the input parameters. Method parameters not assigned at the sequence level shall be assigned at the test plan level.
Output Parameters	List of the output parameters of the method that will be used to determine the pass/fail criteria for the test.
Pass/Fail Criteria	Specifies the limits of the output parameter that will be considered a Pass for the test sequence.

7.3 Sheet Binding Sequence

7.3.1 Introduction

The purpose of this tests sequence is to simulate normal book handling over its lifetime. Real-life stresses include opening and closing the book and manipulating data and visa pages.

7.3.2 Input Parameters

n = Number of sheet bend cycles

P = Sheet to test

7.3.3 Output Parameters

R = Pass/Fail

7.3.4 Sequence

Step No.	S/E	Method		Input Parameters	Output Parm. Measured	Pass/Fail Criteria
1	S	5.1	Conditioning Stress Method	-	-	-
2	S	5.9	Sheet Turning Stress Method	P, n	-	-
3	E	5.10	Sheet Pull Stress Method	P	S	S > 5 N/cm
4	E	6.2	Physical Damage Evaluation Method	-	R	R = Pass

7.4 Storage Climate Sequence

7.4.1 Introduction

The purpose of this tests sequence is to subject the MRP to various climate stresses at which it is expected to be stored.

7.4.2 Input Parameters

T = Temperature at which the passport is can be stored

H = Relative humidity for storage

7.4.3 Output Parameters

R = Pass/Fail

7.4.4 Sequence

Step No.	S/E	Method	Input Parameters	Output Parm. Measured	Pass/Fail Criteria
1	S	5.1	Conditioning Stress Method	-	-
2	S	5.3	Storage Temperature Stress Method	T, H	-
3	S	5.1	Conditioning Stress Method	-	-
5	E	6.1	Functional PIC Evaluation Method	-	R = Pass
6	E	6.2	Physical Damage Evaluation Method	-	R = Pass

7.5 Operational Climate Sequence

7.5.1 Introduction

The purpose of this tests sequence is to subject the MRP to various climate stresses at which it is expected to operate.

7.5.2 Input Parameters

None

7.5.3 Output Parameters

R = Pass/Fail

7.5.4 Sequence

Step No.	S/E	Method		Input Parameters	Output Parm. Measured	Pass/Fail Criteria
1	S	5.1	Conditioning Stress Method	-	-	-
2	S	5.4	Operational Temperature Stress Method	T = -7	-	-
3	E	6.1	Functional PIC Evaluation Method	-	R	R = Pass
4	S	5.4	Operational Temperature Stress Method	T = 47	-	-
5	E	6.1	Functional PIC Evaluation Method	-	R	R = Pass
6	S	5.1	Conditioning Stress Method	-	-	-
7	E	6.2	Physical Damage Evaluation Method	-	R	R = Pass

7.6 Impact Sequence

7.6.1 Introduction

The purpose of this tests sequence is to subject the document to simulated border inspection stamping.

7.6.2 Input Parameters

None

7.6.3 Output Parameters

R = Pass/Fail

7.6.4 Sequence

Step No.	S/E	Method		Input Parameters	Output Parm. Measured	Pass/Fail Criteria
1	S	5.1	Conditioning Stress Method	-	-	-
2	S	5.5	Impact Stress Method	S = chip sheet	-	-
3	E	6.1	Functional PIC Evaluation Method	-	R	R = Pass
4	E	6.2	Physical Damage Evaluation Method	-	R	R = Pass

7.7 Back Pocket Sequence

7.7.1 Introduction

The purpose of this tests sequence is to subject the document to simulated back-pocket stresses. Note that the number of cycles is quite low as sitting on a passport is considered accidental in "normal use".

7.7.2 Input Parameters

None

7.7.3 Output Parameters

R = Pass/Fail

7.7.4 Sequence

Step No.	S/E	Method		Input Parameters	Output Parm. Measured	Pass/Fail Criteria
1	S	5.1	Conditioning Stress Method	-	-	-
2	S	5.6	Book Bend Stress Method (Back Pocket)	n = 10	-	-
3	E	6.1	Functional PIC Evaluation Method	-	R	R = Pass
4	E	6.2	Physical Damage Evaluation Method	-	R	R = Pass
5	E	6.5	Datapage Warpage Evaluation Method	-	R	R = Pass
6	E	6.6	Book Warpage Evaluation Method	-	R	R = Pass

7.8 Torsion Fatigue Sequence

7.8.1 Introduction

The purpose of this tests sequence is to subject the document to torsional forces.

7.8.2 Input Parameters

n = number of twisting cycles

7.8.3 Output Parameters

R = Pass/Fail

7.8.4 Sequence

Step No.	S/E	Method		Input Parameters	Output Parm. Measured	Pass/Fail Criteria
1	S	5.1	Conditioning Stress Method	-	-	-
2	S	5.8	Torsion Stress Method	n	-	-
3	E	6.1	Functional PIC Evaluation Method	-	R	R = Pass
4	E	6.2	Physical Damage Evaluation Method	-	R	R = Pass
5	E	6.5	Datapage Warpage Evaluation Method	-	R	R = Pass
6	E	6.6	Book Warpage Evaluation Method	-	R	R = Pass

7.9 Delamination Sequence

7.9.1 Introduction

The purpose of this tests sequence is to evaluate the inner layer bonds within a passport.

Note: limits are set to ensure book mechanical quality. They are not intended to satisfy any security concerns. (put in the introduction)

7.9.2 Input Parameters

None

7.9.3 Output Parameters

R = Pass/Fail

7.9.4 Sequence

Step No.	S/E	Method		Input Parameters	Output Parm. Measured	Pass/Fail Criteria
1	S	5.1	Conditioning Stress Method	-	-	-
2	E	6.3	Peel Strength Evaluation Method	P = cover sheet	F	F > 0.5 N/cm
3	E	6.3	Peel Strength Evaluation Method	P = data page	F	F > 0.5 N/cm
4	E	6.3	Peel Strength Evaluation Method	P = chip sheet	F	F > 0.5 N/cm

7.10 Bending Fatigue Sequence

7.10.1 Introduction

The purpose of this tests sequence is to evaluate the susceptibility to fatigue of the passport.

7.10.2 Input Parameters

n = number of bending cycles

7.10.3 Output Parameters

R = Pass/Fail

7.10.4 Sequence

Step No.	S/E	Method		Input Parameters	Output Parm. Measured	Pass/Fail Criteria
1	S	5.1	Conditioning Stress Method	-	-	-
2	S	5.7	Dynamic Bend Stress Method	O = spine n	-	-
3	S	5.7	Dynamic Bend Stress Method	O = top n	-	-
4	E	6.1	Functional PIC Evaluation Method	-	R	R = Pass
5	E	6.2	Physical Damage Evaluation Method	-	R	R = Pass
6	E	6.5	Datapage Warpage Evaluation Method	-	R	R = Pass
7	E	6.6	Book Warpage Evaluation Method	-	R	R = Pass

7.11 Thermal Cycling Sequence

7.11.1 Introduction

The purpose of this tests sequence is to evaluate the susceptibility to fatigue due to thermal stresses.

7.11.2 Input Parameters

None

7.11.3 Output Parameters

R = Pass/Fail

7.11.4 Sequence

Step No.	S/E	Method		Input Parameters	Output Parm. Measured	Pass/Fail Criteria
1	S	5.1	Conditioning Stress Method	-	-	-
2	S	5.2	Thermal Cycling Method	n = 20	-	-
3	S	5.1	Conditioning Stress Method	-	-	-
4	E	6.1	Functional PIC Evaluation Method	-	R	R = Pass
5	E	6.2	Physical Damage Evaluation Method	-	R	R = Pass

7.12 Colour Fastness Sequence

7.12.1 Introduction

The purpose of this tests sequence is to evaluate the susceptibility of the document to sunlight.

7.12.2 Input Parameters

None

7.12.3 Output Parameters

R = Pass/Fail

7.12.4 Sequence

Step No.	S/E	Method		Input Parameters	Output Parm. Measured	Pass/Fail Criteria
1	S	5.1	Conditioning Stress Method	-	-	-
2	S	5.14	Artificial Daylight Exposure Stress Method	P = cover S = blue wool scale 6	-	-
3	E	6.4	Colour Fastness Evaluation Method	-	R	R = Pass
4	S	5.14	Artificial Daylight Exposure Stress Method	P = datapage S = blue wool scale 3	-	-
5	E	6.4	Colour Fastness Evaluation Method	-	R	R = Pass
6	S	5.14	Artificial Daylight Exposure Stress Method	P = chip sheet S = blue wool scale 3	-	-
7	E	6.4	Colour Fastness Evaluation Method	-	R	R = Pass

7.13 Resistance to Chemicals Sequence

7.13.1 Introduction

This sequence subjects passports to a range of chemicals that are commonly found in day-to-day situations.

Normally, a sequence would be applied in exactly the same manner to all samples. However for editorial convenience, this sequence covers all of the different solutions, and therefore will require at least 10 passport samples for evaluation.

7.13.2 Input Parameters

None

7.13.3 Output Parameters

R = Pass/Fail

7.13.4 Sequence

Step No.	S/E	Method		Input Parameters	Output Parm. Measured	Pass/Fail Criteria
1	S	5.1	Conditioning Stress Method	-	-	-
2	S	5.13	Resistance to chemicals Evaluation Method	-	-	-
3	E	6.1	Functional PIC Evaluation Method	-	R	R = Pass
4	E	6.2	Physical Damage Evaluation Method	-	R	R = Pass

7.14 Pen Sequence

7.14.1 Introduction

The purpose of this tests sequence is to simulate writing on the passport. As currently defined, the pen test may be destructive to the visa page; therefore, only the chip is evaluated.

7.14.2 Input Parameters

None

7.14.3 Output Parameters

R = Pass/Fail

7.14.4 Sequence

Step No.	S/E	Method		Input Parameters	Output Parm. Measured	Pass/Fail Criteria
1	S	5.1	Conditioning Stress Method	-	-	-
2	S	5.12	Pen Stress Method	n =1 P = writeable page nearest chip (both sides if possible)	-	-
3	E	6.1	Functional PIC Evaluation Method	-	R	R = Pass
4	E	6.2	Physical Damage Evaluation Method	-	R	R = Pass

7.15 Datapage Abrasion Sequence

7.15.1 Introduction

The purpose of this tests sequence is to determine the wear characteristics of the MRZ.

7.15.2 Input Parameters

n = number of abrasion cycles

7.15.3 Output Parameters

R = Pass/Fail

7.15.4 Sequence

Step No.	S/E	Method		Input Parameters	Output Parm. Measured	Pass/Fail Criteria
1	S	5.1	Conditioning Stress Method	-	-	-
2	S	5.11	Abrasion Stress Method	N P = datapage	-	-
3	E	6.2	Physical Damage Evaluation Method	-	R	R = Pass

7.16 X-Ray Sequence

7.16.1 Introduction

The purpose of this tests sequence is to simulate putting a passport through an airport security X-Ray inspection station.

7.16.2 Input Parameters

None

7.16.3 Output Parameters

R = Pass/Fail

7.16.4 Sequence

Step No.	S/E	Method		Input Parameters	Output Parm. Measured	Pass/Fail Criteria
1	S	5.1	Conditioning Stress Method	-	-	-
2	S	5.15	X-Ray Stress Method	-	-	-
3	E	6.1	Functional PIC Evaluation Method	-	R	R = Pass

8 Test plans

8.1 General

The test plan is the top level of the test specification. It specifies values for any undefined sequence parameters, and defines the number of books that need to be subjected to each sequence.

Different test plans are defined depending on what is being tested and why. The default test plan is the "minimum durability required by ICAO". Other test plans can be defined that might set other requirements. For example a 10-year normal use book, or a 5-year heavy use book

Each Lot is composed of new books. Books from one lot shall not be used in the test sequence of another lot.

The lot sizes specify the minimum number of books to be subjected to the test sequence. In general, small lot sizes do not give good statistical results, however very large lot sizes can become expensive to produce and to test. Only absolute minimums are given here. The customer and the tester are free to agree on other lot sizes that are larger than the minimum.

The reader is again reminded that this document is designed to provide a method of prototype testing (Type Approvals). It is not intended to be used to determine if individual documents meet specific standards.

The tester is reminded that while book manufacturers strive for perfect quality, it is possible that faulty samples may be subjected to testing. In the case of a failure, the tester should evaluate the failure, and in consultation with the manufacturer, should decide whether to select another sample for testing.

8.2 Minimum Level Test Plan

This test plan specifies the list of test sequences that shall be passed in order for the document to be considered to meet ICAO's minimum durability level.

Lot No.	Minimum Lot Size	Sequence		Parameters
1	3	7.3	Sheet Binding Sequence	P = cover n = 1000
2	3	7.3	Sheet Binding Sequence	P = datapage n = 1000
3	3	7.3	Sheet Binding Sequence	P = visa page n = 1000
4	3	7.3	Sheet Binding Sequence	P = chip page n = 1000
5	3	7.8	Torsion Fatigue Sequence	n = 500
6	3	7.1 2	Colour Fastness Sequence	-
7	3	7.1 1	Thermal Cycling Sequence	-
8	3	7.1 0	Bending Fatigue Sequence	n = 1000
9	3	7.9	Delamination Sequence	-
10	3	7.6	Impact Sequence	-
11	3	7.4	Storage Climate Sequence	T = 77 H = 50%
11	3	7.4	Storage Climate Sequence	T = -32 H = not specified
12	3	7.5	Operational Climate Sequence	-
13	3	7.6	Impact Sequence	-
14	3	7.7	Back Pocket Sequence	-
15	10 (1 per solution)	7.1 3	Resistance to Chemicals Sequence	-
16	3	7.1 4	Pen Sequence	-
17	3	7.1 5	Datapage Abrasion Sequence	n = 500
18	3	7.1 6	X-Ray Sequence	-
19	3	7.1 1	Thermal Cycling Sequence	-