



NOTA DE INFORMACIÓN

RASG-PA/8 — NI/03 *Revisada*
11/06/15

**Octava Reunión Plenaria Anual del Grupo Regional de Seguridad Operacional de la Aviación -
Panamérica (RASG-PA/8)**
Medellín, Colombia, 25 de junio de 2015

**Cuestión 5 del
Orden del Día:**

**Iniciativas de Seguridad Operacional
5.2 Grupos Regionales de Seguridad Operacional (RASG) de la OACI**

ACTIVIDADES DE LOS RASG EN OTRAS REGIONES

(Presentada por la Secretaría)

RESUMEN EJECUTIVO

Esta nota de información proporciona una actualización sobre las actividades de los otros Grupos Regionales de Seguridad Operacional (RASG) de la OACI.

*Objetivo
Estratégico:*

- Seguridad Operacional

Referencias:

Reuniones de los RASG

- RASG-AFI/2, Dakar (Senegal), 1-2 de noviembre de 2013
(<http://www.icao.int/WACAF/Pages/rasg-afi.aspx>)
- RASG-APAC/4, Hong Kong (China), 20-21 de noviembre de 2014: Restringido
(https://portal.icao.int/RO_APAC/Meetings/Pages/2014-RASG-APAC4.aspx)
- RASG-EUR/04, Paris (Francia), 25-26 de febrero de 2015: Restringido
(<https://portal.icao.int/RASGEUR/Pages/default.aspx>)
- RASG-MID/4, Jeddah, Arabia Saudita, 30 de marzo al 1 de abril de 2015
(<http://www.icao.int/MID/Pages/rasgmid.aspx>)

Informes Anuales Regionales de Seguridad Operacional

- Informe Anual de Seguridad Operacional APAC, segunda edición, noviembre 2014: Restringido
https://portal.icao.int/RO_APAC/Meetings/Documents/APAC%20Safety%20Report%202014.pdf
- Informe Anual de Seguridad Operacional de la Región EUR de la OACI, primera edición a ser publicada en mayo de 2015
- Informe Anual de Seguridad Operacional RASG-MID, tercera edición, marzo 2015
(<http://www.icao.int/MID/Pages/rasgmid.aspx>)

Manuales de Procedimientos de RASG

- RASG-AFI (ver el Apéndice 2F del Informe RASG-AFI/1):
(<http://www.icao.int/WACAF/Pages/rasg-afi.aspx>)

	<ul style="list-style-type: none">• RASG-APAC (ver el Apéndice B del Informe RASG-APAC/1): Restringido https://portal.icao.int/RO_APAC/Meetings/2011%20RASGAPAC1/Report%20RASGrpt.pdf• Tercera Edición RASG-EUR: (http://www.icao.int/EURNAT/Pages/EUR-and-NAT-Document.aspx)• RASG-MID Segunda Edición (ver el Apéndice 4C del Informe Final RASG-MID/2): http://www.icao.int/MID/Pages/rasgmid.aspx)
--	---

1. Introducción

1.1 El 25 de mayo de 2010, con el objetivo de apoyar el marco referencia de la performance regional para la gestión de la seguridad operacional, el 190º Período de Sesiones del Consejo de la OACI aprobó el establecimiento de los siguientes Grupos Regionales de Seguridad Operacional de la Aviación (RASG) adicionales al RASG-PA, el cual fue el primero establecido exitosamente:

- RASG-AFI para la Región de África
- RASG-APAC para las Regiones de Asia y el Pacífico
- RASG-EUR para la Región Europea
- RASG-MID para la Región del Oriente Medio

2. Discusión

2.1 Los **Apéndices A, B, C y D** (*disponibles únicamente en inglés*) a esta nota de información presentan un resumen de los logros de los RASG en las diferentes regiones.

3. Recomendaciones

3.1 Se invita a la Reunión a tomar nota del contenido de esta nota de información.

APPENDIX A

THE REGIONAL AVIATION SAFETY GROUP – AFRICA (RASG-AFI)

1.1 The RASG-AFI was officially established in March 2012 at its first meeting (Kampala, Uganda, 26 and 27 March 2012), during which the administrative structure and terms of reference of the group were agreed. The meeting elected key officials to the positions of Chairperson, Vice Chairpersons and Industry Representative of the group. The meeting also elected Champions of the established subsidiary bodies, called the *Safety Support Teams*. In total, four Safety Support Teams were established in line with the identified areas of priority:

- a) Significant Safety Concerns (SSCs), with the objective of providing assistance to States for the timely resolution of SSCs;
- b) Fundamentals of Safety Oversight (FSO), for the establishment of effective safety oversight systems;
- c) Accident Investigation (AI), to facilitate and coordinate support towards the establishment of effective regional accident investigation organizations (RAIO); and
- d) Emerging Safety Issues, including runway safety, loss of control (LOC) and controlled flight into terrain (CFIT).

1.3 The second meeting of the RASG-AFI was held in Dakar, Senegal in November 2013. This meeting approved the terms of reference of the Safety Support Teams and the proposed RASG-AFI work programme, which was developed based on the prioritization of key safety issues and safety targets adopted by the Abuja Ministerial Meeting in July 2012. The meeting also adopted the AFI Regional Safety Performance Dashboard, which would facilitate the monitoring of progress of Abuja aviation safety targets implementation.

RASG-AFI 2014 Activities:

- Hosted the First AFI Aviation Safety Symposium held in Dakar, Senegal from 27 to 28 May 2014 and attended by 281 participants. One notable outcome was a Collaborative Implementation Programme to be implemented by relevant stakeholders to achieve the regional safety targets, improve aviation safety and air navigation performance in the AFI Region
- Development and launch of the Runway Safety Project related to the Regional Focus Area on Emerging Safety Issues - Runway Safety
- Establishment of Runway Safety Teams at Six International Airports (Nairobi, Harare, Lusaka, Luanda, Kinshasa, Dakar)..
- Through implementation of RASG-AFI activities, Guidance material and tools (in French and English) were developed for the use of the RASG AFI Runway Safety Go-Team and Establishment of a Runway safety team at Dakar International Airport.

RASG-AFI 2015 Scheduled Meetings:

- The Second AFI Aviation Safety Symposium, May 20-21, 2015, Maputo, Mozambique
- RASG-AFI/3, 16-17 October, Cape Verde

RASG-AFI ORGANIZATION

Acting Chairman: Mr. Zakhele G. Thwala, Deputy Director General, South African CAA

RASG-AFI Structure

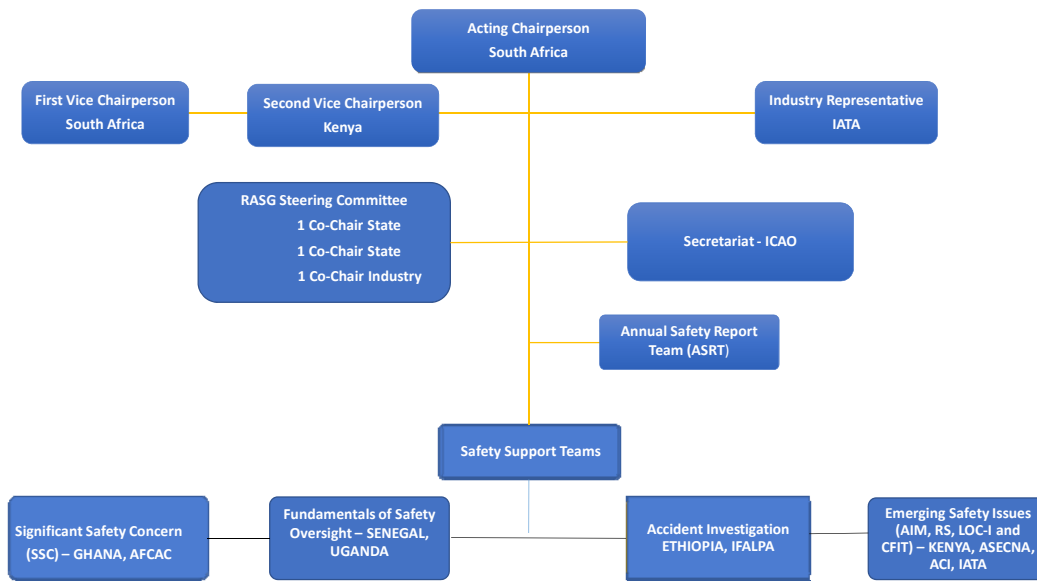

6 May 2015

RASG-AFI

APPENDIX B

THE REGIONAL AVIATION SAFETY GROUP – ASIA AND PACIFIC (RASG-APAC)

1.1 The forty-seventh meeting of Directors General of Civil Aviation of the APAC Regions (DGAC/47), held in Macau (China) from 25 to 29 October 2010, agreed to the establishment of the RASG-APAC. The RASG’s first meeting was held in Noumea (New Caledonia) on 10 and 11 October 2011.

1.2 The RASG-APAC elected a structure similar to that of APANPIRG, whereby the Chairperson and Vice Chairpersons are elected from amongst member States. Contributing bodies such as working groups and ad hoc groups report to the RASG-APAC through the Asia/Pacific Regional Aviation Safety Team (APRAST), which is a subsidiary body that is co-chaired by a member State and an industry partner. The RASG-APAC agreed to establish two ad hoc working groups (AWGs): the Safety Reporting and Programme WG (APAC-SRP) and the Accident Investigation WG (APAC-AIG).

1.3 RASG-APAC has produced two editions of the “RASG-APAC Annual Safety Report.” The 2014 edition contains reactive information relating to hull loss and fatal accidents, both on the ground and in flight, involving commercial aeroplanes operated by (or registered with) the member States/Administrations of the RASG-APAC. This edition also includes proactive information as well as developments in predictive information. It is anticipated that further data will be included in these sections as capability matures. In this report the top three accident categories (in accordance with ICAO/CAST taxonomy) relating to fatality risks, as well as other significant emerging safety hazards in the Asia Pacific region, are identified..

RASG-APAC 2014 Activities

- Implementation of regional priorities and safety targets endorsed by RASG-APAC
- Published APAC Annual Safety Report
- Developed the APAC Code of Conduct on Cooperation relating to Civil Aviation Accident/ Incident Investigation to assist States in accident/incident investigations
- Facilitated regional initiatives to improve the independence in accident investigation and shortage of qualified investigators. Developed incident reporting requirements for States and implemented through RASG-APAC and APRAST
- Developed Model Advisory Circulars (ACs) and Best Practices and Guidance Materials e.g. Model AC on Precision-like Approach Standard Operating Procedures
- Model AC on Minimum Safe Altitude Warning (MSAW), Checklist for Runway Safety Maturity and Guidance on runway maintenance and operations to guide States/Administrations/Industries for safety enhancements on CFIT and runway safety
- Malaysian Air MH370 accident related activities

RASG-APAC Scheduled 2015 Meetings:

- RASG-APAC/5 - Manila, Philippines, 26-27 October

RASG-APAC ORGANIZATION

Chairperson: Mr. H. M. C. NIMALSIRI Director General of Civil Aviation & Chief Executive Officer Civil Aviation Authority of Sri Lanka

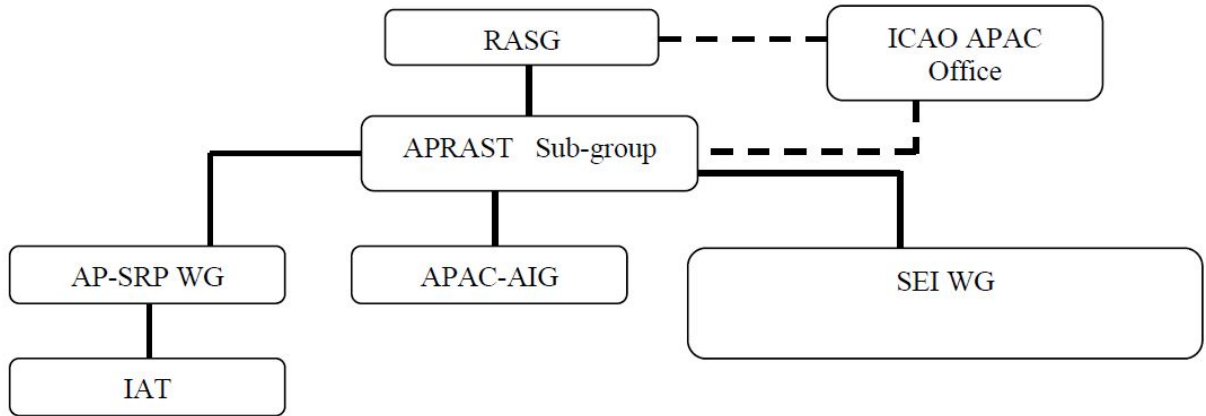

APPENDIX C

THE EUROPEAN REGIONAL AVIATION SAFETY GROUP (RASG-EUR)

1.1 The high-level meeting of European (EUR) Directors General of Civil Aviation, held on 15 and 17 February 2011, agreed to the establishment of the European Regional Aviation Safety Group (RASG-EUR) for the entire ICAO EUR Region. A meeting regarding the actual establishment of the RASG-EUR was convened in Paris in May 2011. The first meeting of the RASG-EUR (RASG-EUR/01) took place in Paris (France) in January 2012.

1.2 The RASG-EUR Co-ordination Group (RCOG) was established by RASG-EUR/01 to coordinate RASG-EUR activities.

1.3 The second meeting of RASG-EUR (RASG-EUR/02, February 2013) agreed to establish the IE-REST as proposed by the RCOG, with the IE-REST reporting to the RASG-EUR via the RCOG and being co-chaired by a State representative and an industry representative. The meeting also approved the RASG-EUR Procedural Handbook, endorsed overall priorities for the RASG-EUR work programme and agreed to promote the “multi-labelling” of safety events in the ICAO EUR Region, as well as to strengthen cooperation with the European Commercial Aviation Safety Team (ECAST) and the EASA Network of Analysts (NoA) through exchange of information and participation in meetings as observers.

1.4 The fourth meeting of the RASG-EUR (RASG-EUR/04) was held in Paris (France) from 25 to 26 February 2015.

1.5 In line with the outcome of the HLSC 2015, the ICAO Secretariat made the following recommendations for the RASG-EUR area:

- State Plans of Action (PoA) should be established for priority States based on safety risk;
- Efforts should be made to align the regional activities of the ICAO Regional Office, the RASG-EUR, the European Aviation Safety Agency (EASA), and the Interstate Aviation Committee (IAC) against priority States and regional safety targets;
- Actions should be prioritized to support improvements in order to resolve SSCs and enhance safety oversight capabilities of the weakest States (with EIs < 60);
- States should request Technical Assistance from ICAO when needed;
- States should request ICAO Coordinated Validation Missions (ICVMs) and/or off-site activities once ready in order to have their EI score updated after validation by ICAO; and
- States should report against regional safety targets and safety performance indicators.

RASG-EUR 2014 Activities:

- Adoption of prioritized safety targets and metrics for the European Regional Aviation Safety Group (RASG EUR).
- Implementation of regional priorities and targets for safety as endorsed by RASG-EUR.
- Effective operation, despite limited resources, of the Regional Aviation Safety Group (RASG-EUR) and in particular the ICAO EUR Regional Expert Safety

Team (IE-REST), established in February 2013 to support the implementation of safety enhancement initiatives in non-EASA States of the ICAO EUR Region.

RASG-EUR 2015 Activities:

- The RASG/04 approved the creation of a Helicopter Safety Team (IE-HOST) reporting to IE-REST.
- Development of a regional mechanism for sharing resources among States to provide safety implementation assistance to States with relatively low EI (Effective Implementation) and high safety risk.

RASG-EUR 2015 Scheduled Meetings:

- RASG-EUR/4 - Paris, France, 25-26 February 2015
- IE-REST/05 - Moscow, Russia, 19-20 May 2015
- RCOG/05 - Paris Office, 03-04 November 2015

RASG-EUR ORGANIZATION

Chairperson: Mr. Gerold Reichle, Director General for Civil Aviation and Aerospace of Germany

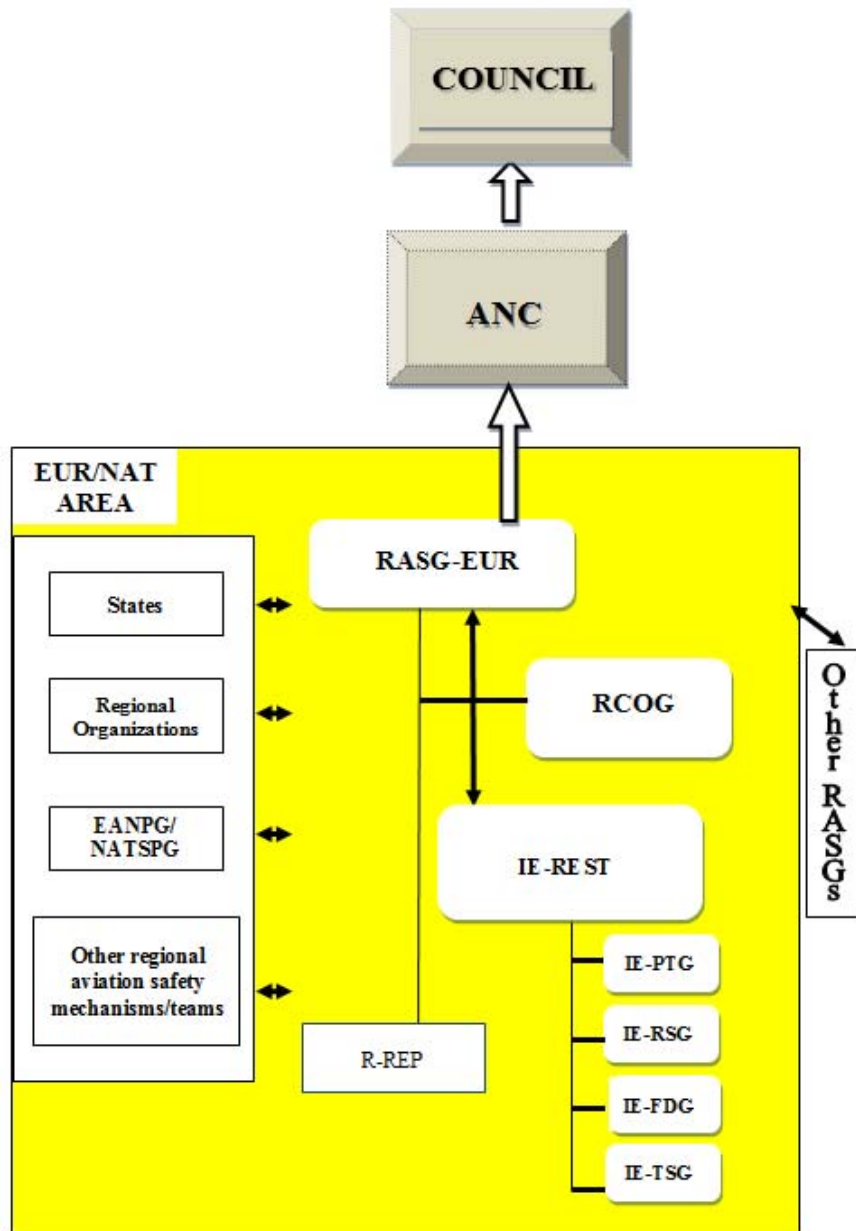

APPENDIX D

THE REGIONAL AVIATION SAFETY GROUP – MIDDLE EAST (RASG-MID)

1.1 RASG-MID has been established following the ICAO Council directive and the Middle East Directors General of Civil Aviation meeting agreement (DGCA-MID/1, United Arab Emirates, 22 - 24 March 2011. The First Meeting of the Middle East Regional Aviation Safety Group (RASG-MID/1) was hosted by the Ministry of Civil Aviation of Egypt in Cairo, Egypt, from 18 to 19 September 2011.

1.2 The current RASG-MID Organizational Structure is shown below. In order to conduct and manage its activities, the RASG-MID has established the following subsidiary bodies:

- The RASG-MID Steering Committee (RSC) to act as an advisory body to the RASG-MID, guide its work and ensure that safety initiatives are accomplished in a timely, effective and efficient manner
- The MID Annual Safety Report Team (MID-ASRT) to gather safety information from different available sources to determine the main aviation safety risks and Focus Areas (FAs) in the MID Region and develop the MID Annual Safety Reports (MID-ASR)
- The Accidents and Incidents Analysis Working Group (AIAWG) was recently established under the MID Annual Safety Report Team (MID-ASRT) to review, analyse and categorize accidents and incidents that occurred in the MID Region or which involved an aircraft registered in the MID Region or owned and/or operated by an Air Operator from the MID Region and provide an agreed and harmonized regional dataset of accidents and incidents
- The MID Regional Aviation Safety Team (MID-RAST) to support the RSC in the development, implementation and monitoring of Safety Enhancement Initiatives (SEIs) and Detailed Implementation Plans (DIPs) related to the identified FAs as well as Emerging Risks (low priorities)
- The Runway and Ground Safety Working Group (RGS WG), which was established under the MID-RAST to address all aerodromes safety activities that were transferred from MIDANPIRG to RASG-MID, and
- The MID Safety Support Team (MID-SST) to support the RSC in the development, implementation and monitoring of SEIs and DIPs related to identified safety issues not directly linked to the agreed FAs such as SSP/SMS implementation, Accident and Incident Investigation and English Language Proficiency

1.3 The RASG-MID membership includes representatives from all States within the area of accreditation of the ICAO Middle East Regional Office. The International Organizations, Regional and Sub-regional Organizations, Industry and any other allied organizations/representatives such as AACO, ACAC, ACI, AIRBUS, BOEING, CANSO, COSCAP-GS, FSF, IATA, IFALPA, IFATCA and WFP participate as Permanent Observers to the RASG-MID and contribute to the work of its subsidiary bodies. The members and observers serve as Partners of RASG-MID and their joint commitment is fundamental for success in improving aviation safety.

RASG-MID 2014 Activities:

- RASG-MID/3 meeting (Kuwait, 27-29 January 2014) and endorsement of the Second MID Annual Safety Report
- Second MID Region Safety Summit (Muscat, Oman, 27 – 29 April 2014) and endorsement of the revised MID Region Safety Strategy
- Development of the Third MID Annual Safety Report
- Development of SEIs and DIPs related to the Regional Focus Areas (Runway Safety, LOC-I and CFIT) in addition to the SSP implementation in the MID Region
- Second MID Regional Runway Safety Seminar which included an Aerodrome Certification Workshop and a Runway Safety Team (RST) Workshop were held in Dubai, UAE, 2 4 June 2014
- Issued RASG-MID Safety Advisory (RSA – 001 and RSA - 002): Guidance for Harmonising the Use & Management of Stop Bars at Airports and Guidance for Regulatory framework for RST establishment
- Establishment of the MID Runway Safety Go-Team with participation of UAE, Egypt, FAA, IATA, and ACI
- The Third meeting of the RASG-MID Steering Committee (RSC/3) was held in Cairo, Egypt, 9-11 December 2014

RASG-MID 2014 Activities:

- RASG-MID/4 meeting (Saudi Arabia, 30 March-1 April 2015) and endorsement of the Third MID Annual Safety Report and the second revision of the Safety Strategy
- Issued RASG-MID Safety Advisory (RSA - 003) including Guidance and Model Checklists for Runway Safety Team
- Issued RASG-MID Safety Advisory– Guidance material related to call sign similarity
- Endorsed RASG-MID Engagement Strategy to outline a strategy and plan for engagement and communication with safety stakeholders and partners in the MID Region to enhance the level of participation in and support to RASG-MID and its subsidiary bodies, in order to achieve RASG-MID's objectives

RASG-MID 2015 Scheduled Meetings:

- RASG-MID/4, 30 March – 1 April, Jeddah, Saudi Arabia.
- RSC/4, Cairo, Egypt, 14-16 December 2015.
- Various teams meetings (MID-SST and RGS WG).

RASG-MID ORGANIZATION

Chairperson: Mr. Ismaeil Mohammed Al Balooshi, Executive Director of Aviation Safety Affairs Sector, GCAA, UAE

