



Egyptian Civil Aviation Authority
Safeguarding Department



Aerodromes Safeguarding Assessment & Management

ASAsM-C100 Vr. 1.2

Case Study

Instructor::

Angie Mostafa, Engineer
Head of Aerodrome's Safety and
Standards Central Administration



Cases Study



1 Calculation Concepts.

2 Simple Case of OLS.

3 Multiple Case of OLS

4 Complex Cases

1 – Calculation Concepts :

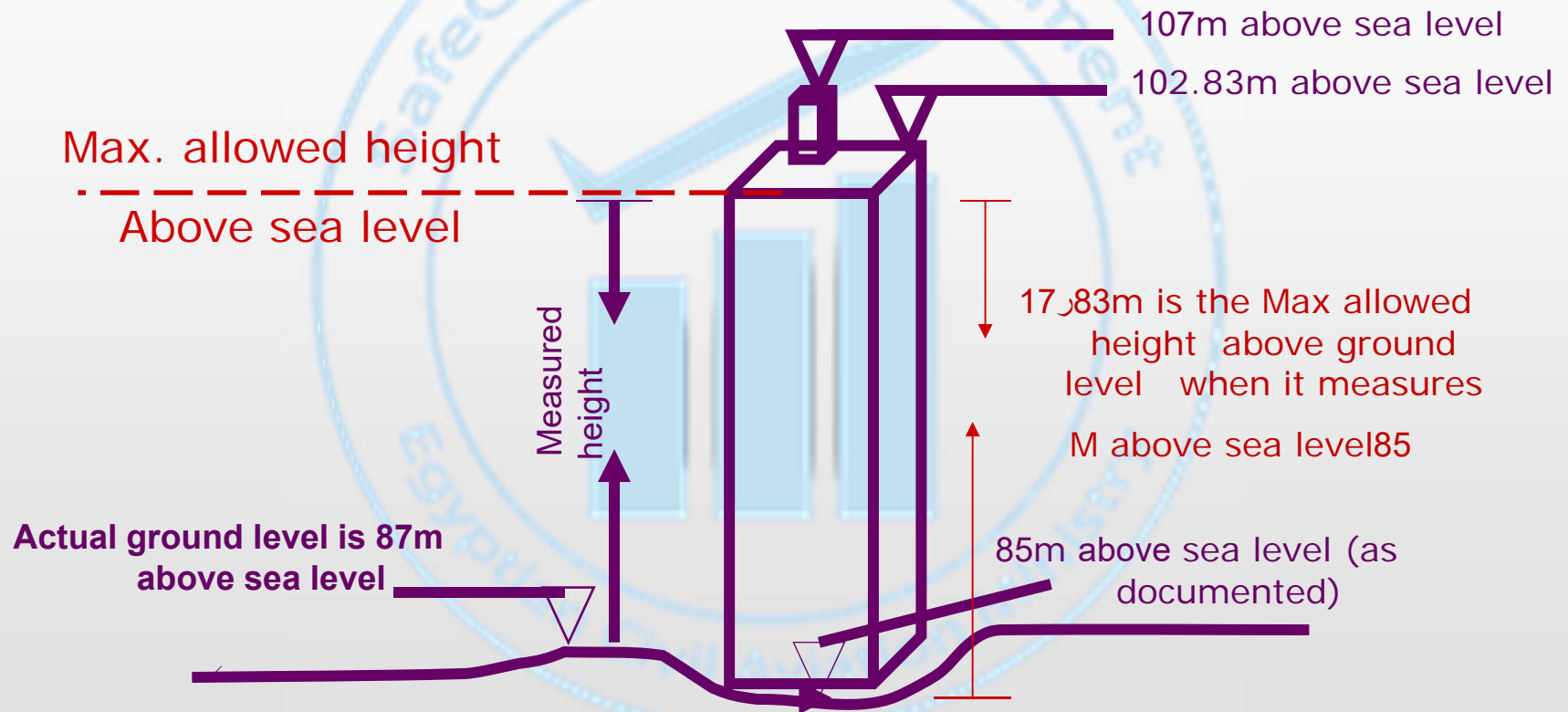



Cases Study



1 Calculation Concepts.

2 Simple Case of OLS.

3 Multiple Case of OLS

4 Complex Cases



Cases Study:



2 – Simple Case of OLS:

- | | |
|------------|-------------------------|
| 2-a | Inner Horizontal |
| 2-b | Outer Horizontal |
| 2-c | Transitional |
| 2-d | Inner Transitional |
| 2-e | First stage of Approach |
| 2-f | Inner Approach |
| 2-g | Take Off |

2 – Simple Case of OLS:

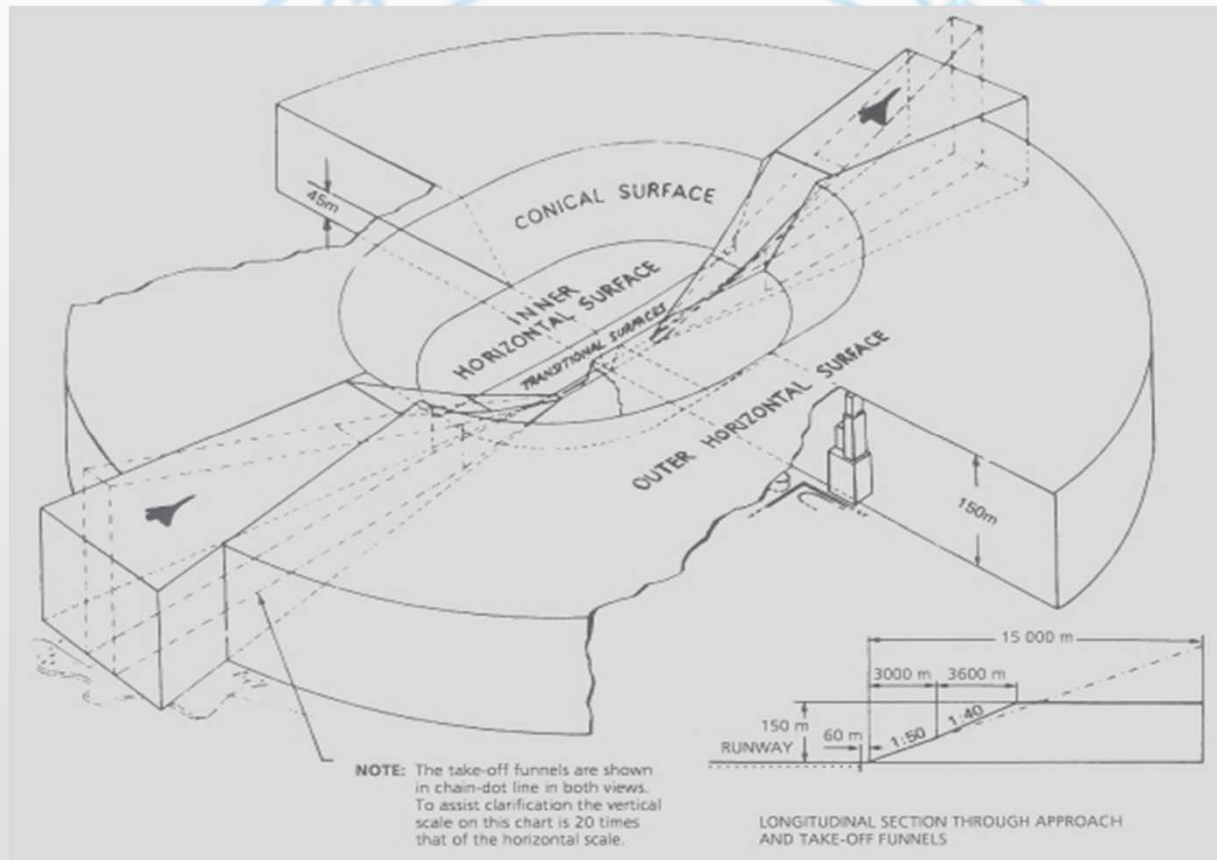

2 – Simple Case of OLS:

Table 7.1-1: Approach Runways

OLS & Dimensions (in metres and percentages)	Runway Classification										
	Non-instrument				Instrument						
	Code No				Non-precision			Precision			
	1*	2	3	4	1,2	3	4	I Code No	3,4	II & III Code No	
OUTER HORIZONTAL											
Height (m)									150	150	
Radius (m)									15000	15000	
CONICAL											
Slope	5%	5%	5%	5%	5%	5%	5%	5%	5%	5%	
Height (m)	35	55	75	100	60	75	100	60	100	100	
INNER HORIZONTAL											
Height (m)	45	45	45	45	45	45	45	45	45	45	
Radius (m)	2000	2500	4000	4000	3500	4000	4000	3500	4000	4000	
APPROACH											
Length of inner edge (m)	60	80	150 ^a	150	90	150	300 ^b	150	300	300	
Distance from threshold (m)	30	60	60	60	60	60	60	60	60	60	
Divergence each side	10%	10%	10%	10%	15%	15%	15%	15%	15%	15%	
First section length (m)	1600	2500	3000	3000	2500	3000	3000	3000	3000	3000	
Slope	5%	4%	3.33%	2.5%	3.33%	3.33%	2%	2.5%	2%	2%	
Second section length (m)	-	-	-	-	-	3600 ^c	3600	12000	3600	3600	
Slope	-	-	-	-	-	2.5% ^c	2.5%	3%	2.5%	2.5%	
Horizontal section length (m)	-	-	-	-	-	8400 ^c	8400	-	8400	8400	
Total length (m)	1600	2500	3000	3000	2500	15000 ^d	15000	15000	15000	15000	
INNER APPROACH											
Width (m)								90	120	120	
Distance from threshold (m)								60	60	60	
Length (m)								900	900	900	
Slope								2.5%	2%	2%	
TRANSITIONAL											
Slope	20%	20%	14.3%	14.3%	20%	14.3%	14.3%	14.3%	14.3%	14.3%	
INNER TRANSITIONAL											
Slope								40%	33.3%	33.3%	
BAULKED LANDING											
Length of inner edge (m)								90	120	120	
Distance from threshold (m)								*	1800 ^f	1800	
Divergence each side								10%	10%	10%	
Slope								4%	3.3%	3.3%	

All distances are measured horizontally unless otherwise specified.

* Runways used for RPT operations at night by aircraft with maximum take-off mass not exceeding 5,700 kg are required to meet code 2 standards.

^a 90 m where width of runway is 30 m.

^b 150 m if only used by aeroplanes requiring 30 m wide runway.

Table 7.1-2: Take-off runways

Take-off climb surface – Dimensions (in metres and percentages)	Take-off Runways Code number		
	1*	2 ^a	3 or 4
Length of inner edge	60	80	180 ^b
Minimum distance of inner edge from runway end ^c	30	60	60
Rate of divergence (each side)	10%	10%	12.5%
Final width	380	580	1800 ^d
Overall length	1600	2500	15000
Slope	5%	4%	2% ^e



2 – Simple Case of OLS:

Aerodrome : non-instrument code 3
: Non-precision code 1
: Precision code 4
: Take-off code 2



6 – Study Cases :



6-2 – Simple Case of OLS:

- | | |
|------------|-------------------------|
| 2-a | Inner Horizontal |
| 2-b | Outer Horizontal |
| 2-c | Transitional |
| 2-d | Inner Transitional |
| 2-e | First stage of Approach |
| 2-f | Inner Approach |
| 2-g | Take Off |

2 – Simple Case :

2-a Inner horizontal.

- **outside of the Airport**

OLS & Dimensions (in metres and percentages)	Runway Classification									
	Non-instrument				Instrument					
	Code No				Non-precision			Precision		
	1*	2	3	4	Code No			I Code No	II & III Code No	
				1, 2	3	4	1, 2	3, 4	3, 4	
INNER HORIZONTAL										
Height (m)	45	45	45	45	45	45	45	45	45	45
Radius (m)	2000	2500	4000	4000	3500	4000	4000	3500	4000	4000

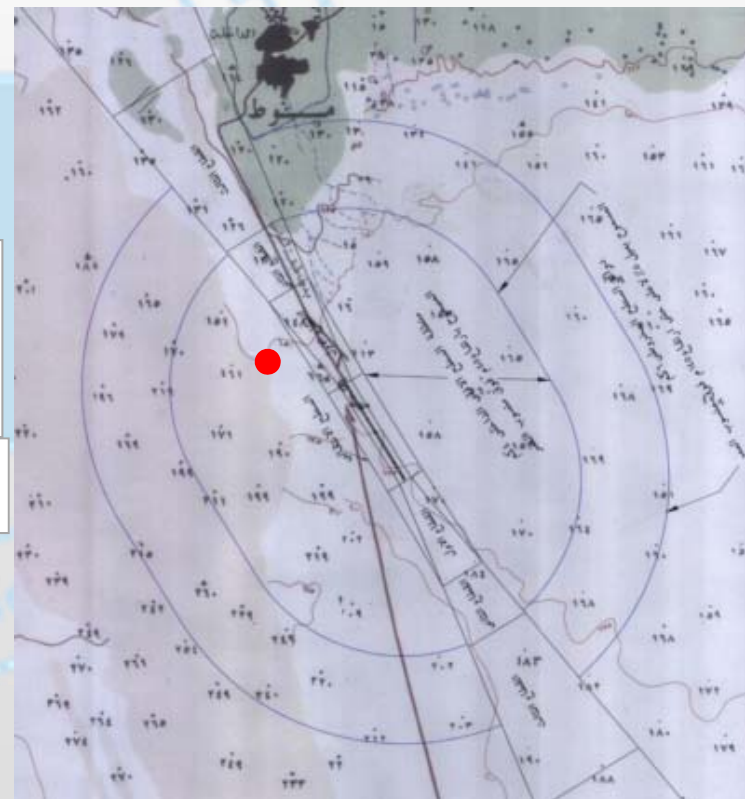

Study Cases :

2 – Simple Case :

2-a Inner horizontal.

HEBL AD 2.12 RUNWAY PHYSICAL CHARACTERISTICS			١٢-٢ الخواص الطبيعية للمدارج		
Designations RWY NR رقم الدلالة رقم المدرج	True BRG الاتجاه الحقيقي	Dimensions of RWY (M) أبعاد المدرج بالمتر	Strength (PCN) and surface of RWY and SWY قوة التحمل ونوع الرصيف للمدرج و منطقة التوقف	THR coordinates, RWY end coordinates & THR geoid undulation إحداثيات العتبة وإحداثيات نهاية المدرج وتنوع هيئة الأرض العتبية لعتبة المدرج	THR ELEV & highest ELEV of TDZ of precision APP RWY منسوب العتبة و أعلى منسوب لفتحة التلامس
1	2	3	4	5	6
15	149.95°	3000 X 45	PCN 70/F/B/W/U ASPH	222315.64N 0313615.94E GUND 33FT	THR 616FT
33	329.96°	3000 X 45	PCN 70/F/B/W/U ASPH	222151.21N 0313708.45E GUND 33FT	THR 616FT

inside the Airport

Abo Simble Airport

Elevation of the location ground	32.7m
Height of the object	6m
Elevation of the top of the object	38.7m
Distance to the threshold 16	1145.88
Elevation of the threshold 16	187.75
Distance to the threshold 34	1976.008
Elevation of the threshold 34	187.75
Perpendicular Distance to the RW	481.297

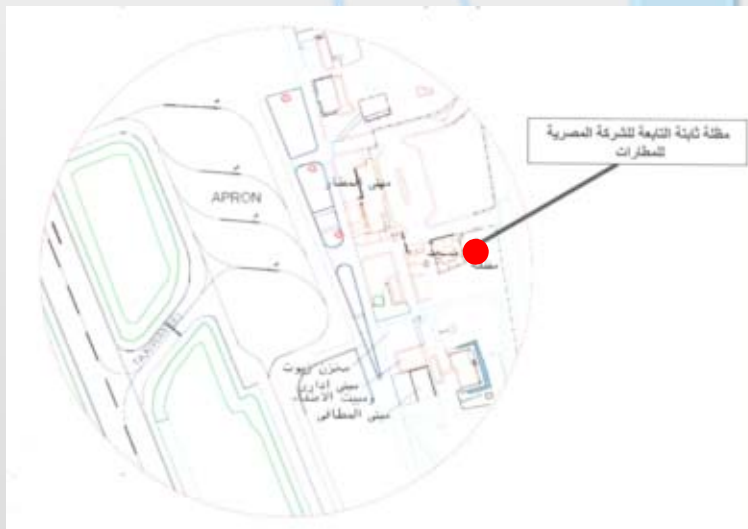

Cases Study :

2 – Simple Case :

2-b Outer horizontal.

OLS & Dimensions (in metres and percentages)	Runway Classification									
	Non-instrument				Instrument					
	Code No				Non-precision			Precision		
	1*	2	3	4	Code No		I Code No		II & III Code No	
				1, 2	3	4	1, 2	3, 4	3, 4	
OUTER HORIZONTAL										
Height (m)								150	150	
Radius (m)								15000	15000	
CONICAL										

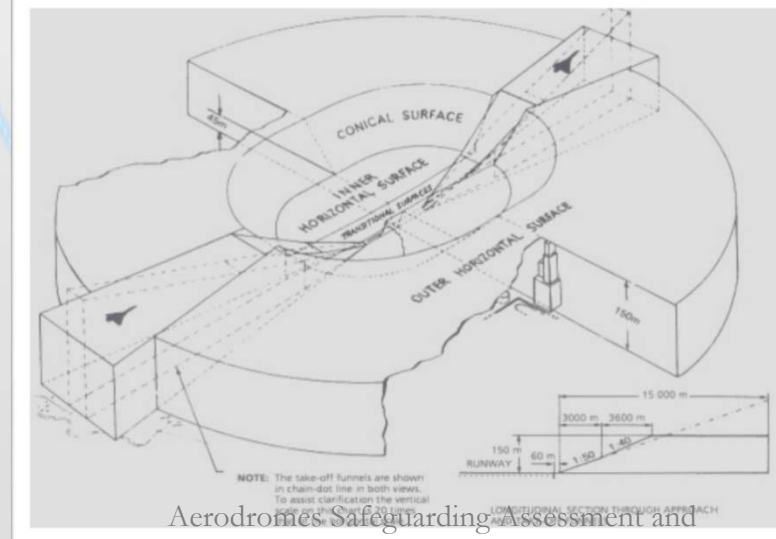

Aerodromes Safeguarding Assessment and Management Course version N

Cases Study :

2 – Simple Case :

2-b Outer horizontal.



HEBL AD 2.12 RUNWAY PHYSICAL CHARACTERISTICS				١٢-٢ الخواص الطبيعية للمدارج	
Designations RWY NR رقم الدلالة رقم المدرج	True BRG الاتجاه الحقيقي	Dimensions of RWY (M) أبعاد المدرج بالمتر	Strength (PCN) and surface of RWY and SWY قوة التحمل ونوع الرصيف للمدرج و مطلة التوقف	THR coordinates, RWY end coordinates & THR geoid undulation إحداثيات العتبة و إحداثيات نهاية المدرج وتسوية هيئة الأرض المقابلة لعتبة المدرج	THR ELEV & highest ELEV of TDZ of precision APP RWY مستوى العتبة و أعلى مستوى لنقطة التلامس
1	2	3	4	5	6
15	149.95°	3000 X 45	PCN 70/F/B/W/U ASPH	222315.64N 0313615.94E GUND 33FT	THR 616FT
33	329.96°	3000 X 45	PCN 70/F/B/W/U ASPH	222151.21N 0313708.45E GUND 33FT	THR 616FT

Airport

Elevation of the location ground	32.7m
Height of the object	6m
Elevation of the top of the object	38.7m
Distance to the threshold 16	1145.88
Elevation of the threshold 16	30.866
Distance to the threshold 34	1976.008
Elevation of the threshold 34	36.72
Perpendicular Distance to the RW	8381.297

Cases Study :

2 – Simple Case :

2-c Transitional

OLS & Dimensions (in metres and percentages)	Runway Classification									
	Non-instrument				Instrument					
	Code No				Non-precision			Precision		
	1*	2	3	4	Code No			I Code No	II & III Code No	
				1, 2	3	4	1, 2	3, 4	3, 4	
TRANSITIONAL										
Slope	20%	20%	14.3%	14.3%	20%	14.3%	14.3%	14.3%	14.3%	14.3%

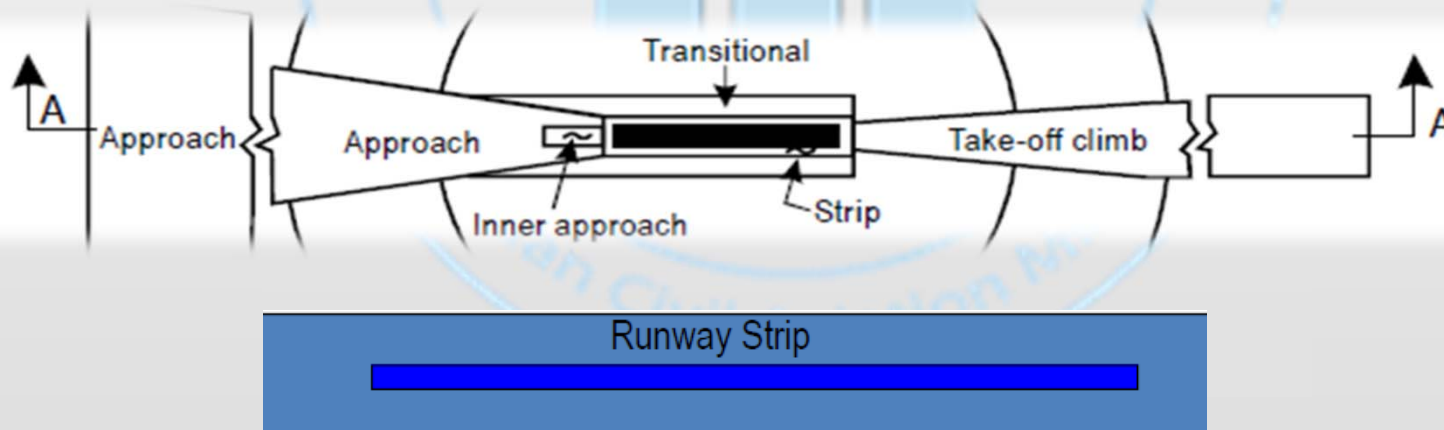

Cases Study:

2 – Simple Case :

2-c Transitional

HEBL AD 2.12 RUNWAY PHYSICAL CHARACTERISTICS					
Designations RWY NR رقم الدلالة رقم المدرج	True BRG الاتجاه الحقيقي	Dimensions of RWY (M) أبعاد المدرج بالمتر	Strength (PCN) and surface of RWY and SWY قوة التحمل ونوع الرصيف للمدرج و منطقة التوقف	THR coordinates, RWY end coordinates & THR geoid undulation إحداثيات العتبة و إحداثيات نهاية المدرج وتسوية هيئة الأرض المائتة لعتبة المدرج	THR ELEV & highest ELEV of TDZ of precision APP RWY منسوب العتبة و أعلى منسوب لقفلة التلاس
1	2	3	4	5	6
15	149.95°	3000 X 45	PCN 70/F/B/W/U ASPH	222315.64N 0313615.94E GUND 33FT	THR 616FT
33	329.96°	3000 X 45	PCN 70/F/B/W/U ASPH	222151.21N 0313708.45E GUND 33FT	THR 616FT

- Case 1: non-instrument 1
non-instrument 3/4
- Case 2: non-precision 1
non-precision 3/4
- Case 3: precision ?

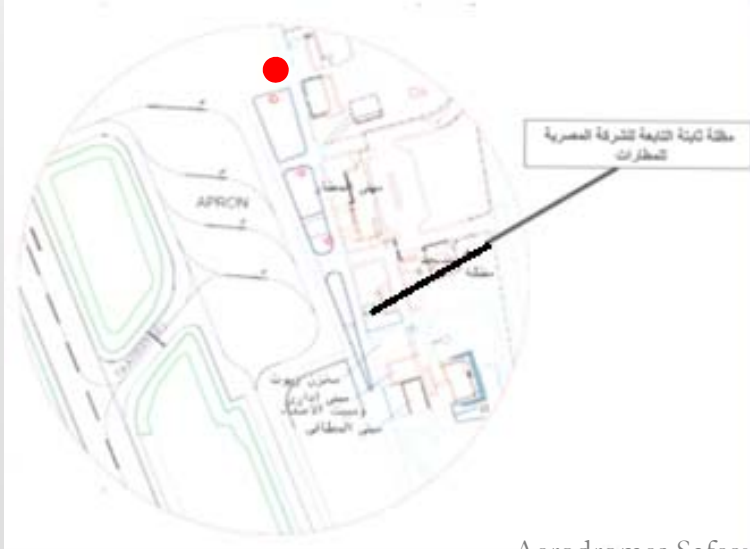

Abo Simble Airport	
Elevation of the location ground	32.7m
Height of the object	6m
Elevation of the top of the object	38.7m
Distance to the threshold 16	1145.88
Elevation of the threshold 16	30.866
Distance to the threshold 34	1976.008
Elevation of the threshold 34	36.724
Perpendicular Distance to the RW	300

Cases Study:

2 – Simple Case :

2-d Inner Transitional

OLS & Dimensions (in metres and percentages)	Runway Classification										
	Non-instrument				Instrument						
	Code No				Non-precision			Precision			
	1*	2	3	4	Code No		1, 2	3, 4	I Code No	II & III Code No	
INNER TRANSITIONAL											
Slope								40%	33.3%	33.3%	

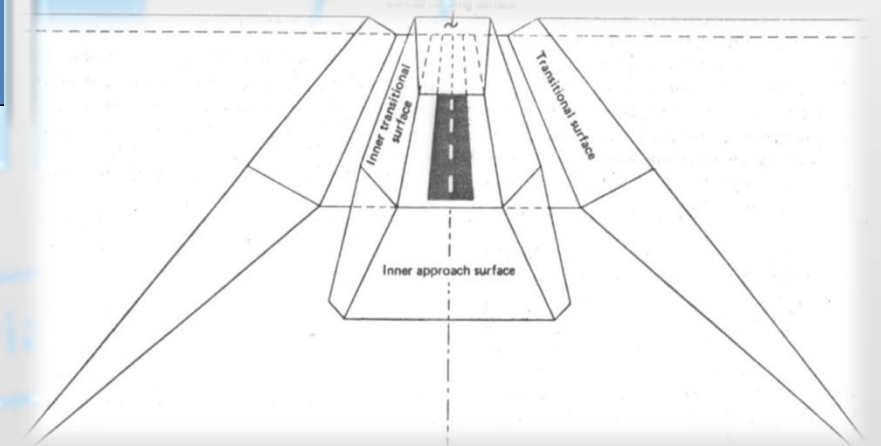
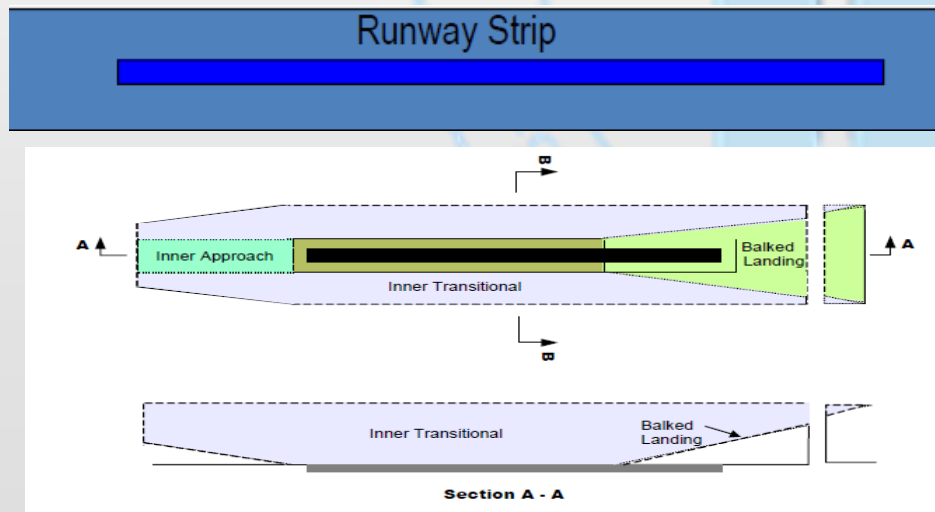

Cases Study:

2 – Simple Case :

2-d Inner Transitional

- Case 1: non-instrument 1
non-instrument 2
- Case 2: non-precision 1
non-precision 3
- Case 3: precision ?

HEBL AD 2.12 RUNWAY PHYSICAL CHARACTERISTICS					
Designations RWY NR رقم الدلالة رقم المدرج	True BRG الاتجاه الحقيقي	Dimensions of RWY (M) أبعاد المدرج بالمتر	Strength (PCN) and surface of RWY and SWY قوة التحمل ونوع الرصيف للمدرج و منطقة التوقف	THR coordinates, RWY end coordinates & THR geoid undulation إحداثيات العتبة و إحداثيات نهاية المدرج وتوج هيئة الأرض المعقبة لعتبة المدرج	THR ELEV & highest ELEV of TDZ of precision APP RWY منسوب العتبة و أعلى منسوب لعتبة التلامس
1	2	3	4	5	6
15	149.95°	3000 X 45	PCN 70/F/B/W/U ASPH	222315.64N 0313615.94E GUND 33FT	THR 616FT
33	329.96°	3000 X 45	PCN 70/F/B/W/U ASPH	222151.21N 0313708.45E GUND 33FT	THR 616FT

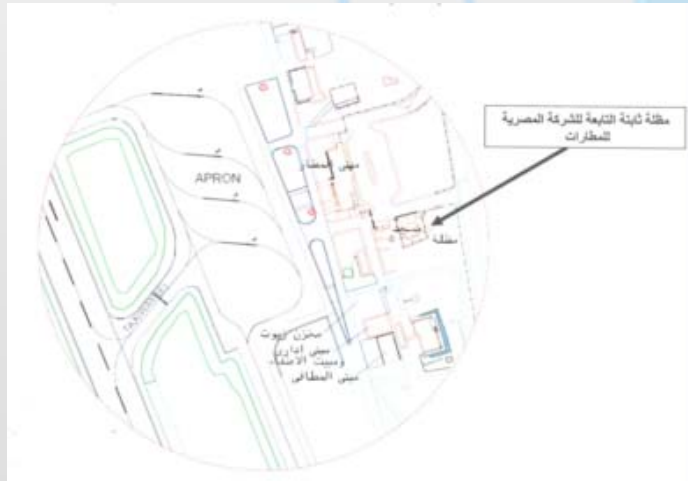

Abo Simble Airport	
Elevation of the location ground	32.7m
Height of the object	6m
Elevation of the top of the object	38.7m
Distance to the threshold 16	1145.88
Elevation of the threshold 16	30.866
Distance to the threshold 34	1976.008
Elevation of the threshold 34	36.724
Perpendicular Distance to the RW	285

135m after strip total of 285 form center line

Cases Study:

2 – Simple Case :

2-d Extended Transitional

- Case 1: non-instrument 1
non-instrument 2
- Case 2: non-precision 1
non-precision 3
- Case 3: precision ?

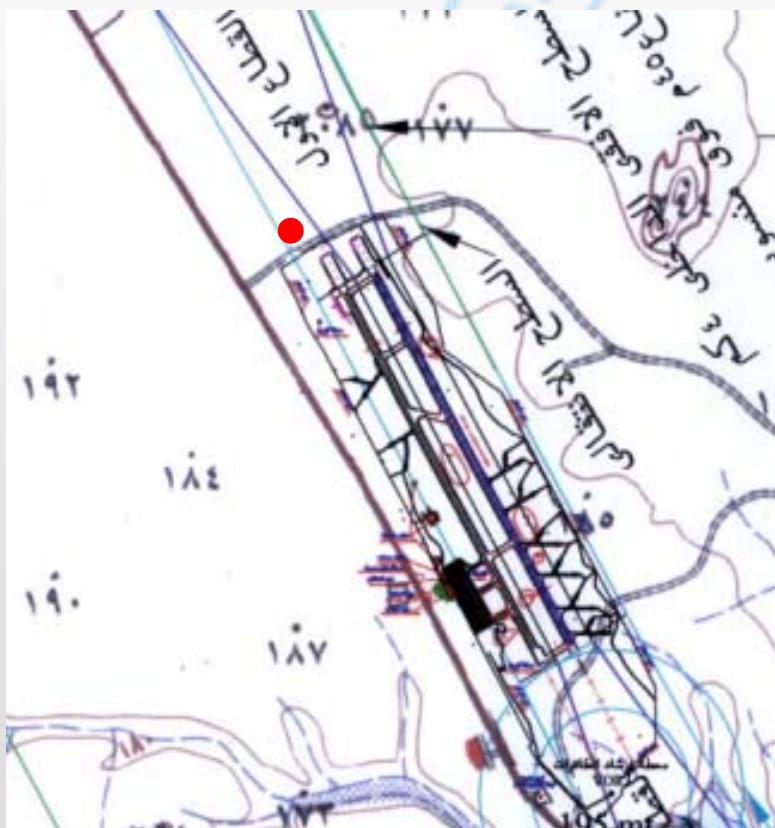

Abo Simble Airport

Elevation of the location ground	32.7m
Height of the object	6m
Elevation of the top of the object	38.7m
Distance to the threshold 16	1145.88
Elevation of the threshold 16	30.866
Distance to the threshold 34	1976.008
Elevation of the threshold 34	36.724
Perpendicular Distance to the RW	300

2- Simple Case :

2-e First Stage of Approach

Approach Surface

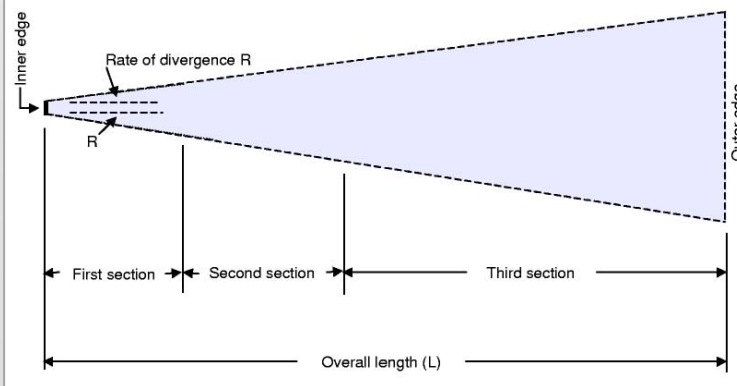
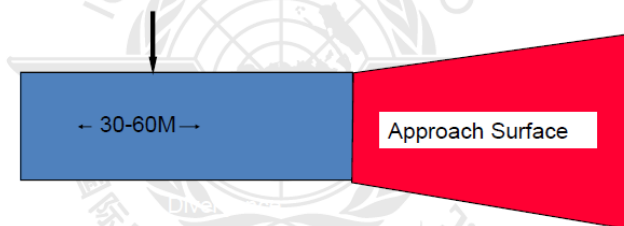

OLS & Dimensions (in metres and percentages)	Runway Classification									
	Non-instrument				Instrument					
	Code No				Non-precision			Precision		
	1*	2	3	4	Code No		I Code No		II & III Code No	
				1, 2	3	4	1, 2	3, 4	3, 4	
APPROACH										
Length of inner edge (m)	60	80	150 ^a	150	90	150	300 ^b	150	300	300
Distance from threshold (m)	30	60	60	60	60	60	60	60	60	60
Divergence each side	10%	10%	10%	10%	15%	15%	15%	15%	15%	15%
First section length (m)	1600	2500	3000	3000	2500	3000	3000	3000	3000	3000
Slope	5%	4%	3.33%	2.5%	3.33%	3.33%	2%	2.5%	2%	2%
Second section length (m)	-	-	-	-	-	3600 ^c	3600	12000	3600	3600
Slope	-	-	-	-	-	2.5% ^c	2.5%	3%	2.5%	2.5%
Horizontal section length (m)	-	-	-	-	-	8400 ^e	8400	-	8400	8400
Total length (m)	1600	2500	3000	3000	2500	15000 ^d	15000	15000	15000	15000

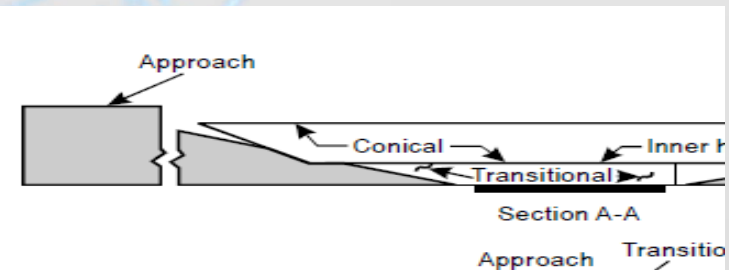

Cases Study:

2– Simple Case :

2-e First Stage of Approach

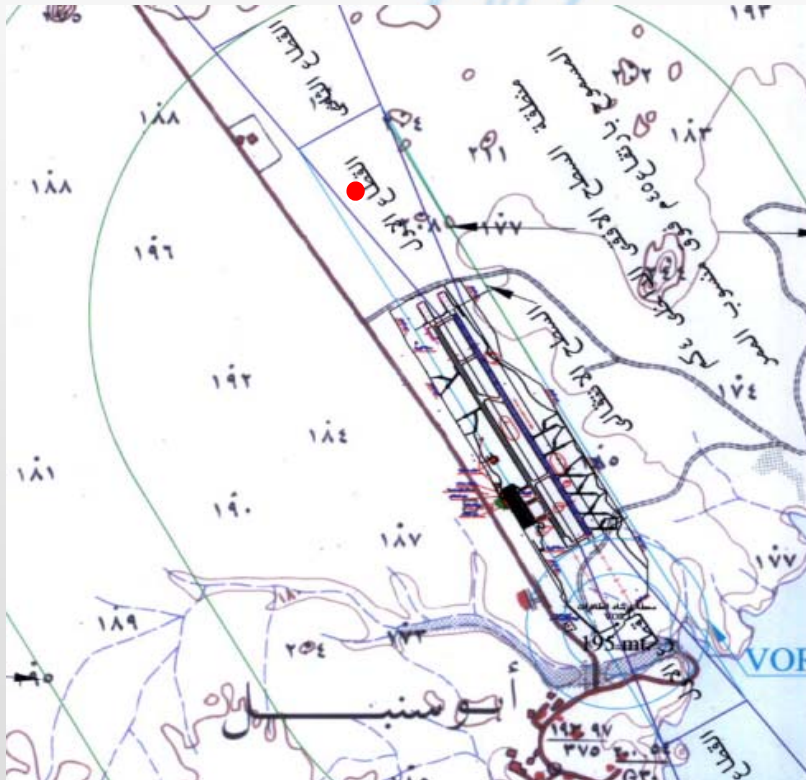

- Case 1: non-instrument 1
non-instrument 2
- Case 2: non-precision 2
non-precision 4
- Case 3: precision I/III 4

Abo Simble Airport

Elevation of the location ground	32.7m
Height of the object	6m
Elevation of the top of the object	38.7m
Distance to the threshold 16	1145.88
Elevation of the threshold 16	30.866

Cases Study:

2 – Simple Case :

2-f Inner approach

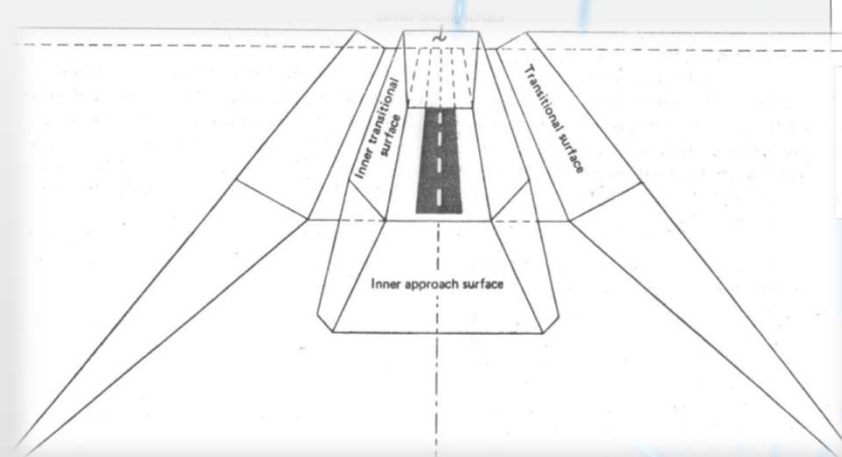

OLS & Dimensions (in metres and percentages)	Runway Classification									
	Non-instrument				Instrument					
	Code No				Non-precision			Precision		
	1*	2	3	4	Code No			I Code No	II & III Code No	
				1, 2	3	4	1, 2	3, 4	3, 4	
INNER APPROACH										
Width (m)								90	120	120
Distance from threshold (m)								60	60	60
Length (m)								900	900	900
Slope								2.5%	2%	2%

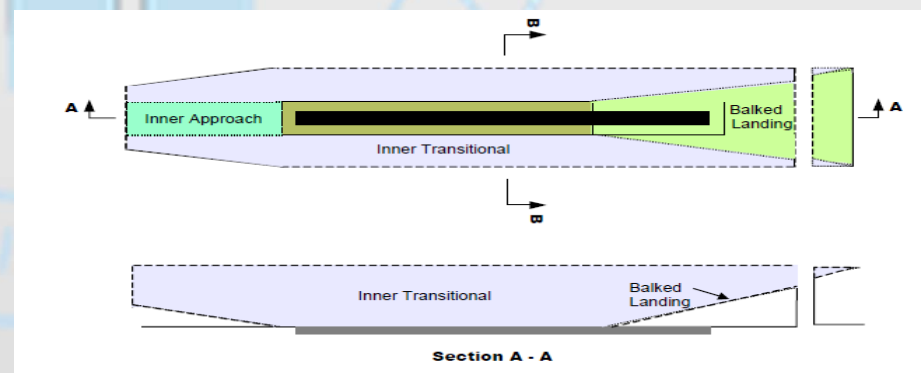

Cases Study :

2 – Simple Case :

2-f Inner approach

Case 1: precision I-2
2: II-3



Abo Simble Airport

Elevation of the location ground	32.7m
Height of the object	6m
Elevation of the top of the object	38.7m
Distance to the threshold 16	750
Elevation of the threshold 16	30.866

- normally it's approach lights
- or Nav. Aide equipment

Cases Study:

2 – Simple Case :

2-g Take Off Surface

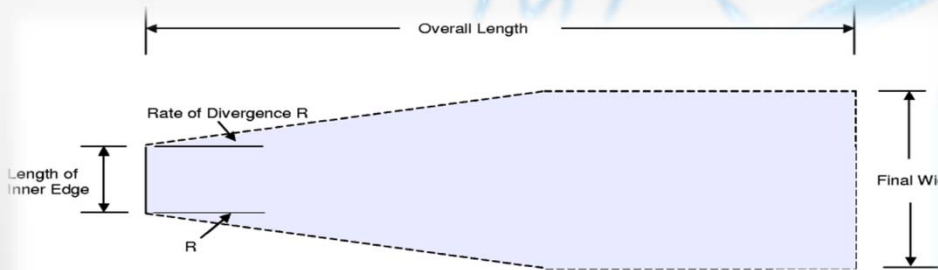
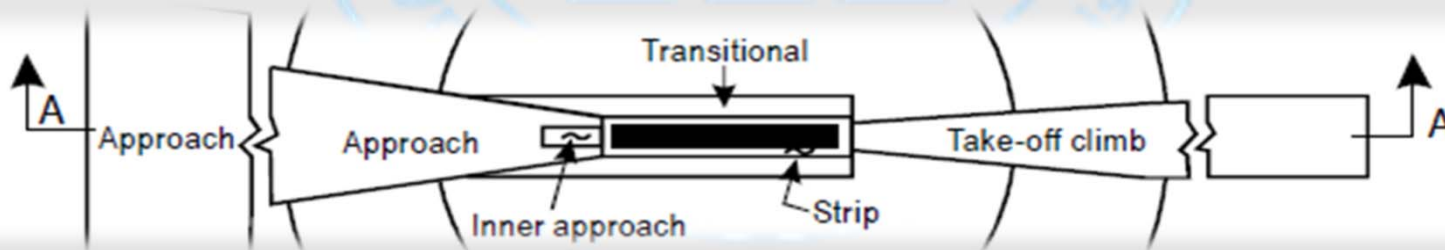

Table 7.1-2: Take-off runways

Take-off climb surface – Dimensions (in metres and percentages)	Take-off Runways Code number		
	1 ^a	2 ^a	3 or 4
Length of inner edge	60	80	180 ^b
Minimum distance of inner edge from runway end ^c	30	60	60
Rate of divergence (each side)	10%	10%	12.5%
Final width	380	580	1800 ^d
Overall length	1600	2500	15000
Slope	5%	4%	2% ^e



Cases Study:

2 – Simple Case :

2-g Take Off Surface



Case 1: Code 1
Code 2
Code 3/4

Abo Simble Airport	
Elevation of the location ground	32.7m
Height of the object	6m
Elevation of the top of the object	38.7m
Distance to the threshold 16	4600
Elevation of the threshold 16	30.866



Agenda:



Cases Study

1 Calculation Concepts.

2 Simple Case of OLS.

3 Multiple Cases

4 Complex Cases

Cases Study :

3 – Multiple Cases :

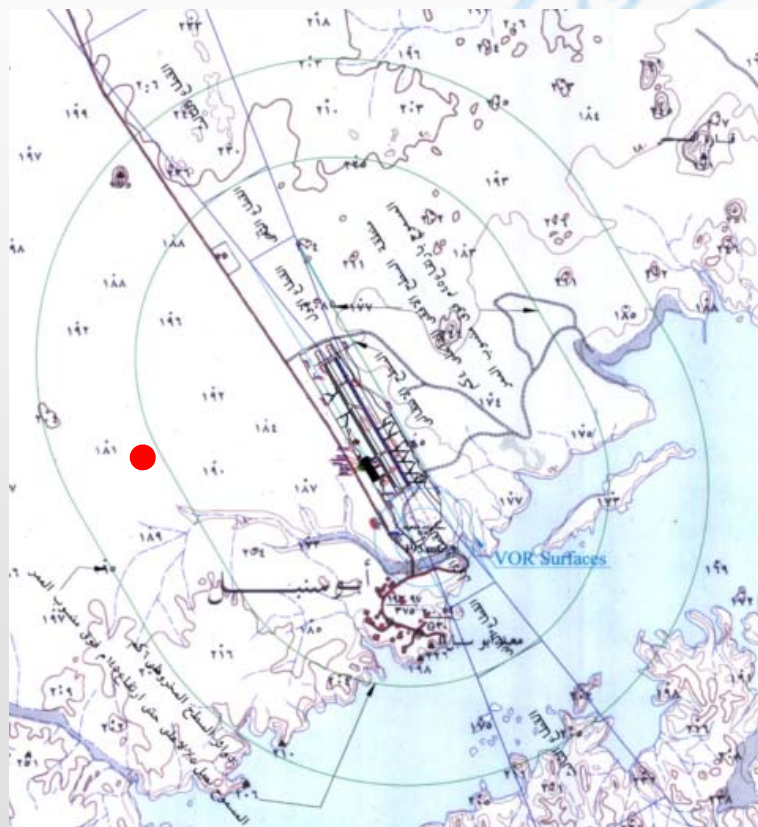

OLS & Dimensions (in metres and percentages)	Runway Classification									
	Non-instrument				Instrument					
	Code No				Non-precision			Precision		
	1*	2	3	4	Code No			I Code No		II & III Code No
				1, 2	3	4	1, 2	3, 4	3, 4	
CONICAL										
Slope	5%	5%	5%	5%	5%	5%	5%	5%	5%	5%
Height (m)	35	55	75	100	60	75	100	60	100	100

Abo Simble Airport	
Elevation of the location ground	32.7m
Height of the object	6m
Elevation of the top of the object	38.7m
Distance to the threshold 16	1145.88
Elevation of the threshold 16	30.866
Distance to the threshold 34	1976.008
Elevation of the threshold 34	36.724
Perpendicular Distance to the RW	4600

• One Surface with Multiple Calculation Case.

Cases Study :

3 – Multiple Cases :

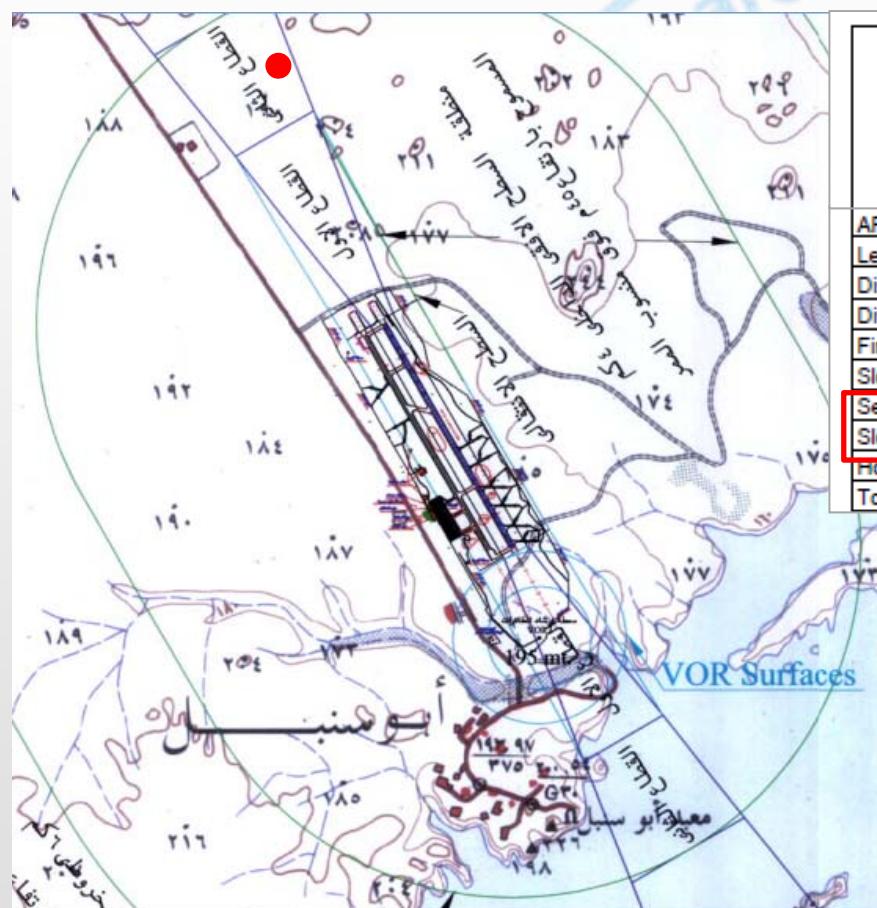

OLS & Dimensions (in metres and percentages)	Runway Classification									
	Non-instrument				Instrument					
	Code No				Non-precision			Precision		
	1*	2	3	4	Code No		I Code No		II & III Code No	
				1, 2	3	4	1, 2	3, 4	3, 4	
APPROACH										
Length of inner edge (m)	60	80	150*	150	90	150	300 ^b	150	300	300
Distance from threshold (m)	30	60	60	60	60	60	60	60	60	60
Divergence each side	10%	10%	10%	10%	15%	15%	15%	15%	15%	15%
First section length (m)	1800	2500	3000	3000	2500	3000	3000	3000	3000	3000
Slope	5%	4%	3.33%	2.5%	3.33%	3.33%	2%	2.5%	2%	2%
Second section length (m)	-	-	-	-	-	3600 ^c	3600	12000	3600	3600
Slope	-	-	-	-	-	2.5% ^c	2.5%	3%	2.5%	2.5%
Horizontal section length (m)	-	-	-	-	-	8400	8400	-	8400	8400
Total length (m)	1800	2500	3000	3000	2500	15000 ^d	15000	15000	15000	15000

Abo Simple Airport

Elevation of the location ground	32.7m
Height of the object	6m
Elevation of the top of the object	38.7m
Distance to the threshold 16	4000
Elevation of the threshold 16	30.866

Second Section of approach

Aerodromes Safeguarding Assessment and Management Course version N

Cases Study :

3 – Multiple Cases :



Alex. Airport	
Elevation of the location ground	32.7m
Height of the object	6m
Elevation of the top of the object	38.7m
Distance to the threshold 04	1145.88
Elevation of the threshold 04	30.866
Distance to the threshold 22	1976.008
Elevation of the threshold 22	36.724
Perpendicular Distance to the RW 04/22	1381.289
Distance of the threshold 18	1145
Elevation of the threshold 18	
Distance to the threshold 36	1976
Elevation of the threshold 36	
Perpendicular Distance to the RW 18/36	450

• Double Surfaces (inner)

Aerodromes Safeguarding Assessment and Management Course version N

4 – Complex Cases :

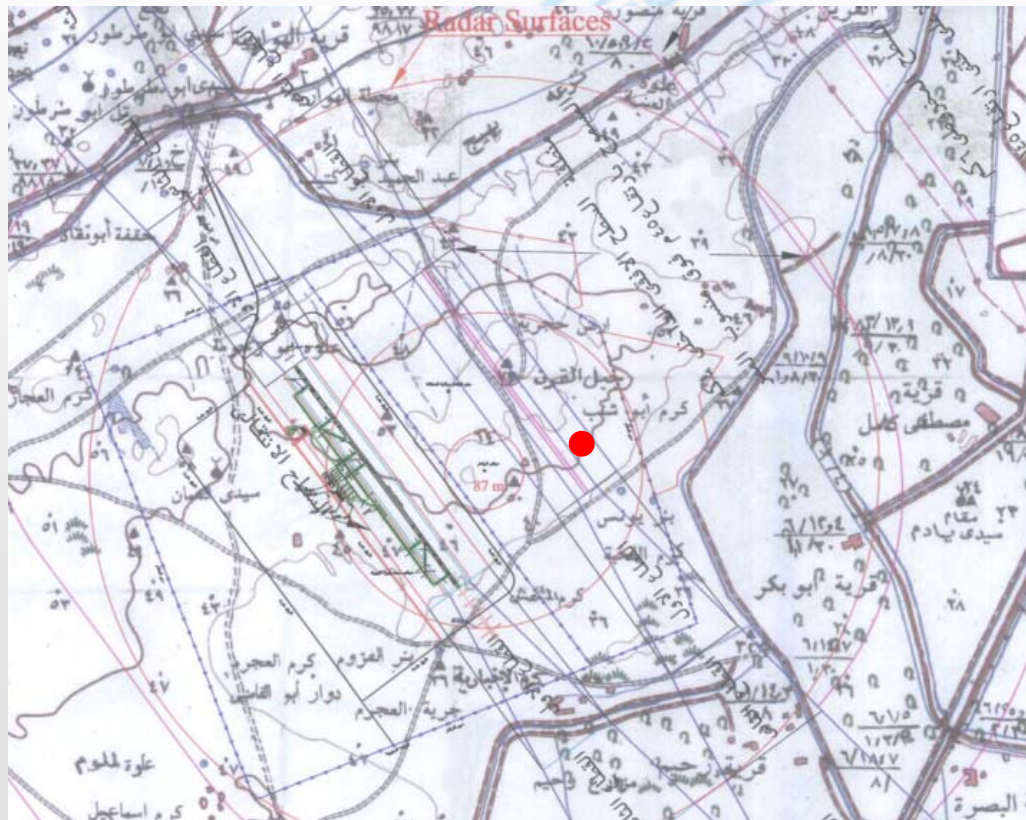

HEBA AD 2.12 RUNWAY PHYSICAL CHARACTERISTICS				١٢-٢ الخواص الطبيعية للمدارج	
Designations RWY NR رقم الدلالة رقم المدرج	True BRG الاتجاه الحقيقي	Dimensions of RWY (M) أبعاد المدرج بالمتر	Strength (PCN) and surface of RWY and SWY قوة التحمل ونوع الرصيف للمدرج ومنطقة التوقف	THR coordinates, RWY end coordinates & THR geoid undulation إحداثيات العتبة و إحداثيات نهاية المدرج وتموج هيئة الأرض المقتبة لعتبة المدرج	THR ELEV & highest ELEV of TDZ of precision APP RWY مسوب العتبة و أعلى مسوب للطبقة الثلاثين
1	2	3	4	5	6
14	142.85°	3400 X 45	PCN 55/F/B/W/U ASPH	305549.32N 0294106.31E GUND 48FT	THR 177FT
32	322.86°			305421.31N 0294223.64E GUND 48FT	THR 133FT

Airport	
Elevation of the location ground	32.7m
Height of the object	6m
Elevation of the top of the object	38.7m
Elevation of the threshold 14R	30.866
Elevation of the threshold 23L	36.72
Distance of the threshold 14L	36.724
Elevation of the threshold 23R	36.724
Perpendicular Distance to the RW 14R/23L	300
Perpendicular Distance to the RW 18/36	1237
Distance to the radar	1237.467
Elevation of top of the radar	59.856

• Transitional / Inner / Radar

Aerodromes Safeguarding Assessment and
Management Course version N

Cases Study:

4 – Complex Cases :



Airport	
Elevation of the location ground	32.7m
Height of the object	6m
Elevation of the top of the object	38.7m
Elevation of the threshold 34	36.724
Elevation of the threshold 16	30.866
Distance of the threshold 34	1300
Distance to the VOR	802.663
Elevation of top of the VOR	42.467

• Approach / VOR

Aerodromes Safeguarding Assessment and Management Course version N

Cases Study:

4 – Complex Cases :

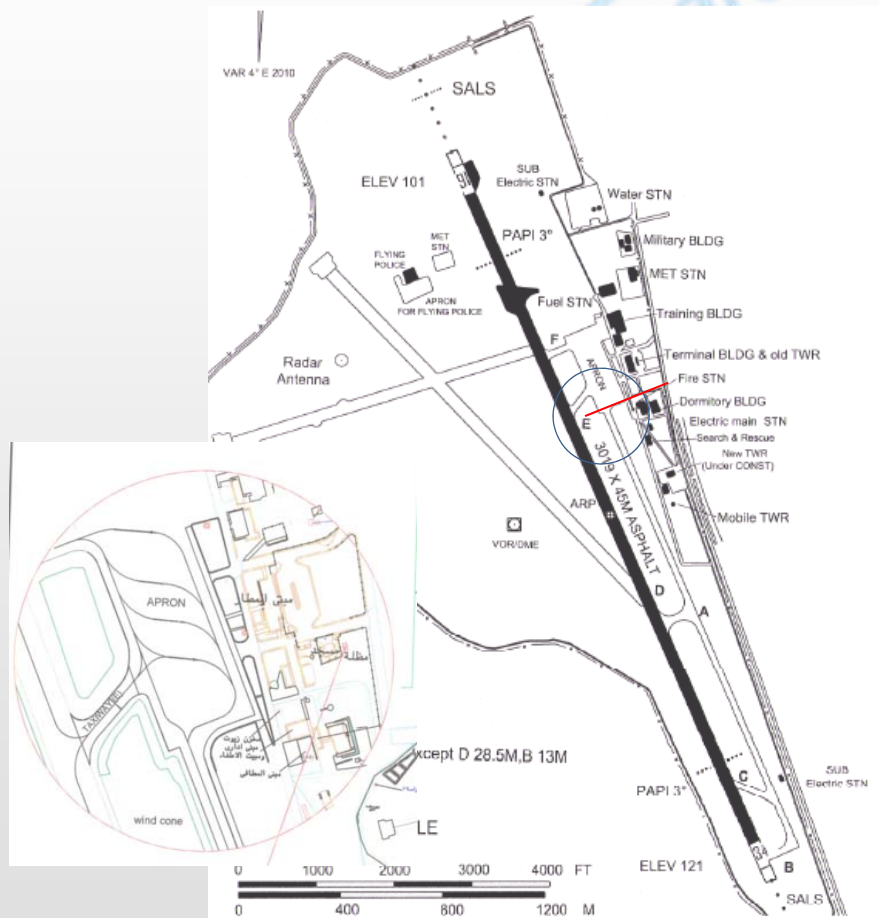

Elevation of t location ground	32.7
Height of the object	6 m
Elevation of the top of the object	38.7
Distnce to the threshold 16	1145.88
Elevation of the threshold 16	30.866
Distance the threshold 34	1976.008
Elevation of the threshold 34	36.72
Perpendicular the Distance to the runway 16/34	381.29
Distance to the VOR	802.663
Elevation of the VOR	42.46
Distance to the metrological sensors	933.078
Elevation of top of Radar	59.85
Distance to the Radar	1237.46
Distance to the NDB	539.49
Elevation of the NDB	39.47

Any Construction inside the airport

Aerodromes Safeguarding Assessment and Management Course version N

4 – Complex Cases :

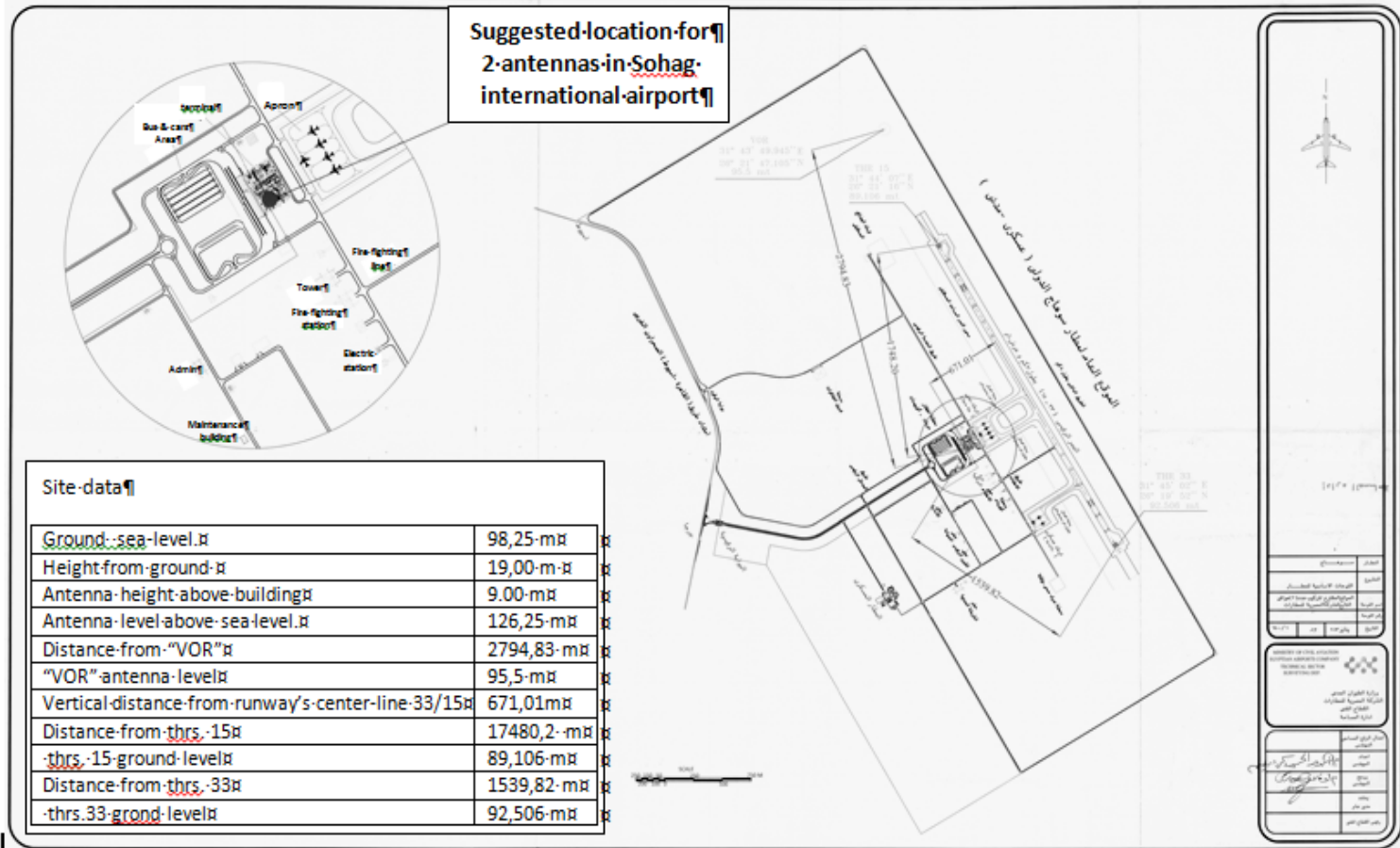

Any Construction inside the airport

Aerodromes Safeguarding Assessment and Management Course version N