



ATNS ADS/CPDLC

Frank Majaramhepo: Systems Specialist

ROAD TO ADS-CPDLC

- ADS/CPDLC implemented in 2000



ROAD TO ADS-CPDLC

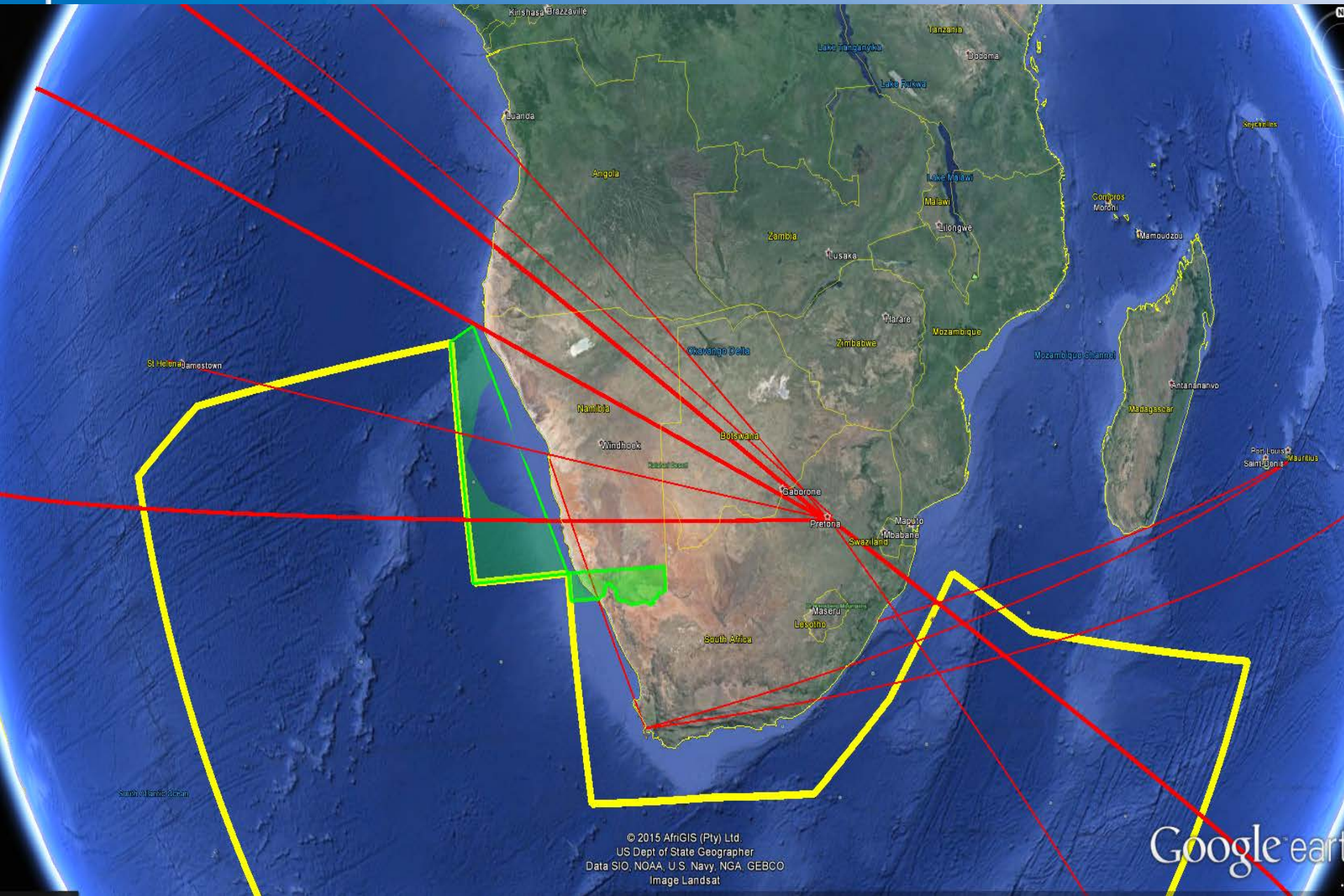

ROAD TO ADS-CPDLC

CSP

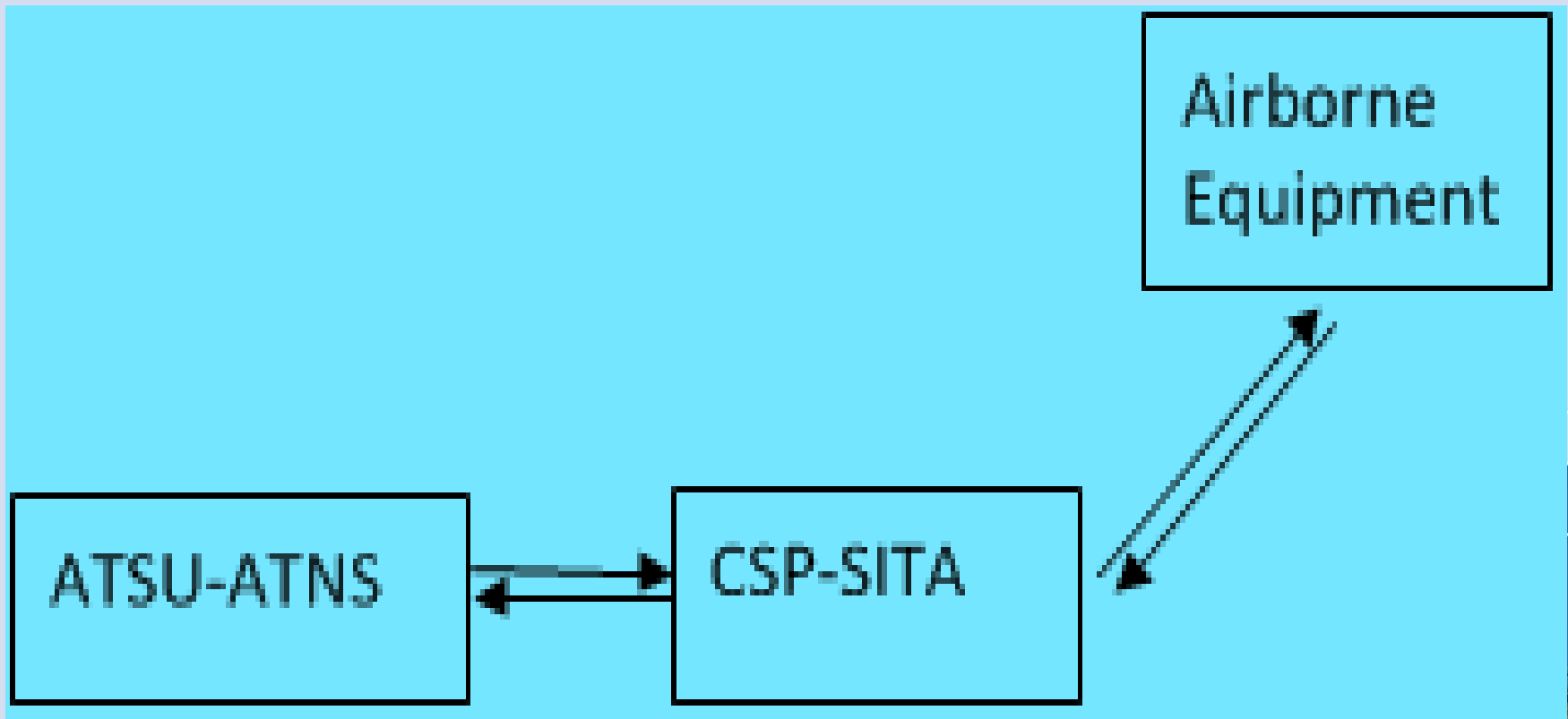

OPERATIONAL EXPERIENCE-ATM System Capability

Button Categories: Message Sets(Uplink)

CLIMB- *Expect climb at, Climb to*

DESCEND – *Expect descent at, Descent to*

ROUTE-*Proceed direct to, Hold at, Cleared to*

SPEED- *Reduce speed to*

FREE TEXT- *discouraged*

ANSWER – *Roger, Unable, Standby*



OPERATIONAL EXPERIENCE-ATM System Capability

- Some earlier models require a software upgrade
- Some require enhancement of existing applications
- Current ATM systems have ADS/CPDLC Interface



OPERATIONAL EXPERIENCE-Challenges

Aircraft equipage

- FANS1/A
- Even where ADS/CPDLC contact exists HF is monitored
- Equipment unserviceability

ATM System

- 99.99% service availability
- Monitoring

Communications

- National Telecommunications Service Providers-Link outages
- No redundancy on ADS/CPDLC



ATC Training

- Commences after Adoption of Operational Procedures (update SSI) and successful Operational Tests and Safety Assessments
- Training of OJTIs by Specialists
- Training for relevant ATCs on the System Support Suite
- Update ATA training curriculum



LOOKING AHEAD

- Implementation of Continental CPDLC:
- AMC
- ACL
- ACM
- Advanced stage of Business Case Review
- POC ready by Q1 2016



END





Contact us

ATNS HEAD OFFICE

Postal address

Private Bag X15
Kempton Park
1620

Street address

Block C, Eastgate Office Park
South Boulevard Road
Bruma 2198
Gauteng
Republic of South Africa

Contact details

Tel: +27 11 928 6536
Fax: +27 11 607 1570
Website: www.atns.co.za
Email: frankm@atns.co.za

THE AVIATION TRAINING ACADEMY

Postal address

Private Bag X1
Bonaero Park
1622

Contact details

Tel: +27 11 570 0400
Fax: +27 11 395 3347

Thank you