

*International Civil Aviation Organization*



**THE TWELFTH WORKING GROUP MEETING OF  
AERONAUTICAL TELECOMMUNICATION NETWORK  
(ATN) IMPLEMENTATION CO-ORDINATION GROUP OF  
APANPIRG (ATNICG WG/12)**



5 – 8 August, Renton, WA, USA

---

**Agenda Item 3: REVIEW ACP WG I/M OUTCOMES**

**AP TO DOC 9880 PART II: AFTN SERVICE MESSAGE  
PROCESSING IN AFTN/AMHS GATEWAY**

(Presented by United States of America)

**SUMMARY**

This paper describes a planned Amendment Proposal to Document 9880 to address a problem in the current AFTN/AMHS gateway specification regarding processing of AFTN SVC messages reporting an unknown addressee indicator.

**1. INTRODUCTION**

1.1 The attached paper aims at submitting to ACP WG-M an amendment proposal regarding Part II of Doc 9880. This AP results from lessons learnt in Europe during AMHS operational service, and it aims at making AFTN and AMHS operation easier while transitioning to the latter.

1.2 It has been identified that the current AFTN/AMHS gateway specification regarding processing of AFTN SVC messages reporting about an unknown addressee indicator makes message interpretation difficult for messaging users and system operators, due a to a partial loss of information at the gateway. This could be enhanced by a limited change to the gateway specification. The change consists in converting all AFTN SVC ADS UNKNOWN messages in AMHS IPMs instead of converting some of them in AMHS NDRs.

1.3 The observation of the problem and the principle of the change proposal were agreed during the work of ICAO AFSG subgroups in Europe. It was noted that the issue is not limited to Europe, and that the amendment proposal should be introduced in Doc 9880 Part II by ACP WG-M. Therefore the AFSG/PG-47 meeting (held in Bratislava, June 2012) tasked France to coordinate this topic with WG-M.

**2. DISCUSSION**

2.1 See Attachment A.

**3. ACTION BY THE MEETING**

3.1 The meeting is invited to:

- a) note the information contained in this paper; and
- b) discuss any relevant matters as appropriate.

-----



International Civil Aviation Organization

ACP-WGM20/WP-pp  
23 January 2013

**WORKING PAPER**

**AERONAUTICAL COMMUNICATIONS PANEL (ACP)**

**20th MEETING OF WORKING GROUP M (Maintenance)**

**Montréal, Canada, 23-25 January 2013**

**Agenda Item 3: ATN/OSI Document 9880 Update Status**

**AP to Doc 9880 Part II: AFTN Service message processing in AFTN/AMHS Gateway**

(Prepared by Jean-Marc Vacher, France)

**SUMMARY**

This paper aims at submitting to ACP WG-M an amendment proposal regarding Part II of Doc 9880. This AP results from lessons learnt in Europe during AMHS operational service, and it aims at making AFTN and AMHS operation easier while transitioning to the latter.

It has been identified that the current AFTN/AMHS gateway specification regarding processing of AFTN SVC messages reporting about an unknown addressee indicator makes message interpretation difficult for messaging users and system operators, due a to a partial loss of information at the gateway. This could be enhanced by a limited change to the gateway specification. The change consists in converting all AFTN SVC ADS UNKNOWN messages in AMHS IPMs instead of converting some of them in AMHS NDRs.

The observation of the problem and the principle of the change proposal were agreed during the work of ICAO AFSG subgroups in Europe. It was noted that the issue is not limited to Europe, and that the amendment proposal should be introduced in Doc 9880 Part II by ACP WG-M. Therefore the AFSG/PG-47 meeting (held in Bratislava, June 2012) tasked France to coordinate this topic with WG-M.

**ACTION**

The working group is invited to comment the Amendment Proposal, and to take appropriate action for approval and integration of the AP in Doc 9880.

## 1. INTRODUCTION

1.1 This paper aims at submitting to ACP WG-M an amendment proposal regarding Part II of Doc 9880. This AP results from lessons learnt in Europe during AMHS operational service, and it aims at making AFTN and AMHS operation easier while transitioning to the latter.

1.2 A problem has been identified in the current AFTN/AMHS gateway specification regarding processing of AFTN SVC messages reporting about an unknown addressee indicator. This could be resolved by a limited change to the gateway specification.

1.3 The observation of the problem and the principle of the change proposal were agreed during the work of ICAO AFSG subgroups in Europe. It was noted that the issue is not limited to Europe, and that the amendment proposal should be introduced in Doc 9880 Part II by ACP WG-M. Therefore the AFSG/PG-47 meeting (held in Bratislava, June 2012) tasked France to coordinate this topic with WG-M.

## 2. REFERENCES

- [1] ICAO Document 9880 AN/466 Part II – Ground-ground communications – Air Traffic Services Message Handling Services (ATSMHS)
- [2] ICAO Annex 10, Volume II
- [3] AFSG/PG47 WP13, AFN SVC Originator of converted NDR
- [4] AFSG/PG48 WP17, Feedback on the proposal to switch off the conversion of AFTN SVC ADS ... UNKNOWN ... into AMHS Non-Delivery-Report
- [5] Report of AFSG/PG47 meeting (Bratislava, June 2012)

## 3. DISCUSSION

3.1 In the AFTN (and AMHS) environment, there is an operational requirement that the recipient of a Non-Delivery Report or an AFTN service message reporting about an unknown addressee indicator (SVC ADS ... UNKNOWN ...) can identify the COM Centre which detected that addresses are unknown. The current AFTN/AMHS gateway specification regarding processing of such AFTN SVC messages makes message interpretation difficult for messaging users and system operators, due a to a partial loss of information at the gateway in certain circumstances.

3.2 The following example was reported by an AMHS system manufacturer in the AFSG/PG48 meeting: an AFTN user in Poland, who sent an AFTN message to the same addresses NFFNYOYX and NFOFNSVC (Location Indicators : Fiji, Nadi Int'l Airport and Notam Office), received an AFTN service message SVC ADS ... UNKNOWN NFFNYOYX NFOFNSVC with the originator indicator EGGGYFAC. On its way from Poland to the Asia/Pac Region the subject message passed the

AMHS link from the UK to Singapore, and vice versa for the service message. So it can be concluded that the original service message was converted into an AMHS NDR by the COM Centre in Singapore and reconverted into an AFTN service message by the COM Centre in London.

3.3 Assuming that the NFFNYOYX and NFOFNSVC AFTN addresses are indeed, for some reason, unknown in the Fiji COM Centre, the operational example described above depicts a gateway behaviour which is compliant with the current Doc 9880 Part II specifications.

3.4 The principles of these technical specifications regarding the processing of these message types are recalled below.

**Case 1 (“primary” processing):**

In the AFTN/AMHS Gateway which receives an AFTN SVC message reporting about an unknown addressee indicator, a single corresponding AMHS subject message can be identified:

=> the AFTN SVC ADS UNKNOWN message is converted into an AMHS Non-Delivery Report (NDR)

This situation is depicted in the figure below.

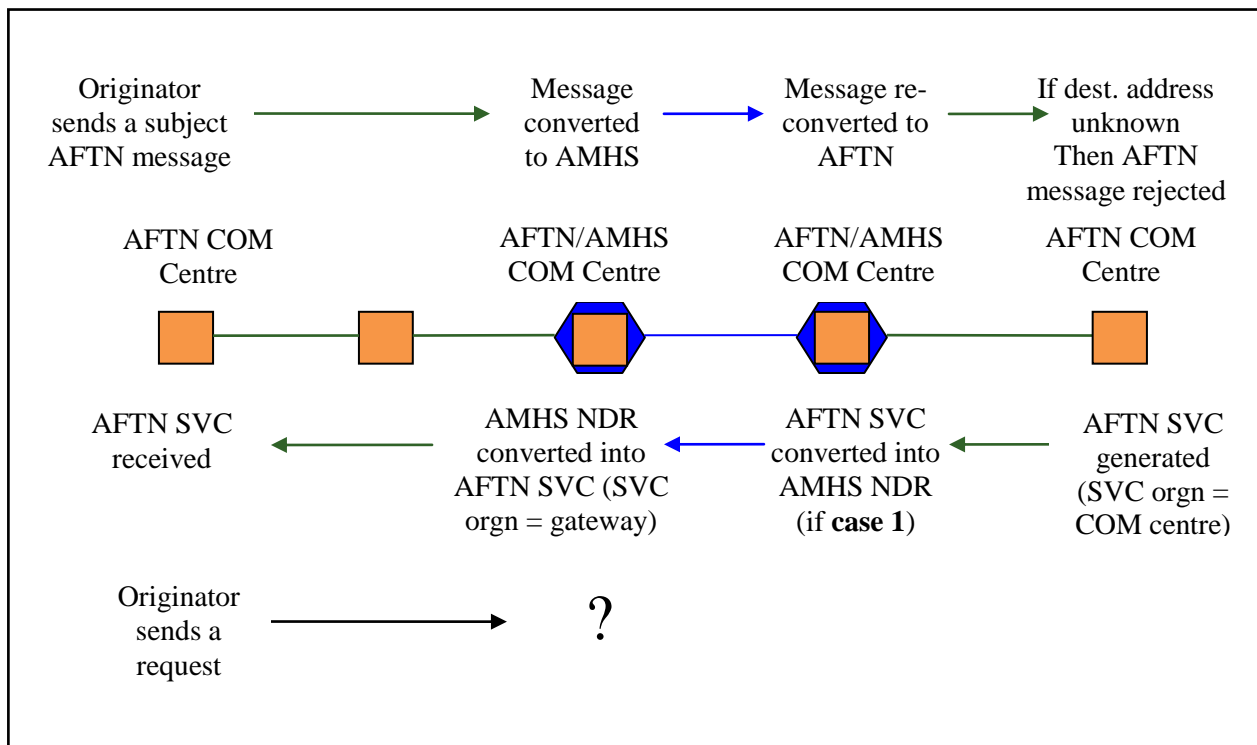

**Case 2 (“secondary” processing, if conditions for primary are not met):**

In the AFTN/AMHS Gateway which receives an AFTN SVC ADS UNKNOWN message, a single corresponding AMHS subject message cannot be identified. Either no subject message is found, or there multiple possible subject messages:

=> the AFTN SVC ADS UNKNOWN message is converted into an AMHS IPM (“normal” message) with subject “AFTN service information”

This situation is depicted in the figure below.

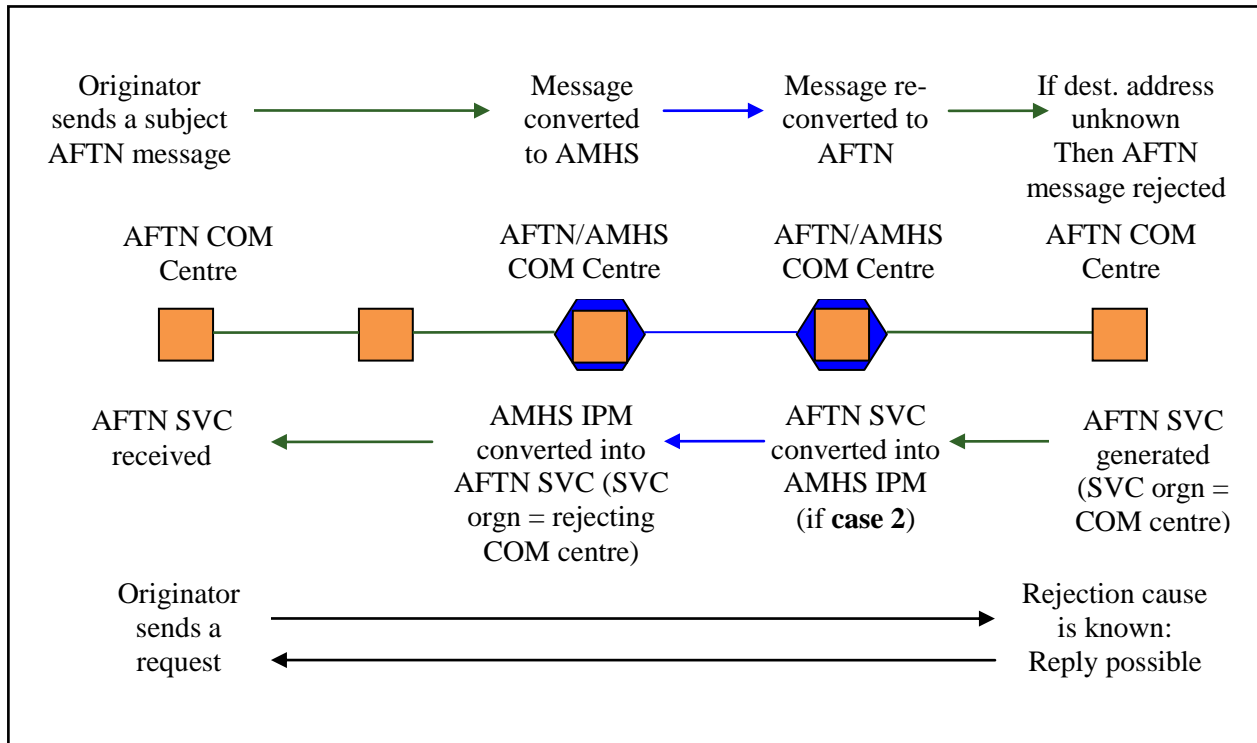

3.5 The scenarios described in the previous section aim at showing that in case 1, there is a partial loss of information in the AFTN SVC message received by the originator of the subject message: the originator of the AFTN SVC message appears to be the gateway which converted the AMHS NDR into the AFTN SVC. The COM Centre where the message was actually rejected is not known nor shown in the AFTN SVC, whilst in most cases only operators of that COM Centre know why addresses are unknown and which replacement addresses could be used. Conversely, in case 2, the AFTN SVC message is converted without taking into account the fact that it is a service message (except for the “Subject” field, which is provided for information and guidance). Because of this approach, the originator of the AFTN SVC message is kept unchanged across gateways while converting the message. The SVC message received by the originator of the subject message contains the address of the rejecting COM centre, which can then be queried to resolve the issue.

3.6 The current technical specifications in Doc 9880 Part II favour case 1 in order to maximise the use of “native” AMHS information objects, i.e. NDRs in the considered situation. Case 2 is considered as an (exceptional) secondary processing, activated only when the conditions for case 1 are not met. However, this logic is contradicted by the operational requirement that the recipient of a Non-

Delivery Report or an AFTN service message SVC ADS ... UNKNOWN ... can identify the COM Centre which detected that addresses are unknown.

3.7 There was consequently a consensus in the AFSG subgroups (Operations Group and Planning Group) to recommend that this logic be abandoned, and that the process corresponding to case 2 (conversion of the AFTN SVC ADS UNKNOWN message into a “normal” IPM) become the standard and single process applied to such an AFTN service message.

3.8 Although the principle of the amendment proposal (convert into IPM instead of NDR) may appear to be significant, it was considered to be easy and with a limited technical impact, because the conversion functionality already exists as part of case 2. Only the driving logic should be modified, and in fact it is a simplification because one single process will remain, instead of a choice between two processes based on several conditions. The system manufacturers participating as observers to the AFSG subgroups confirmed that the change would be minor in terms of software changes.

3.9 The corresponding Amendment Proposal is submitted as an Attachment to this WP.

#### 4. **ACTION BY THE MEETING**

4.1 The working group is invited to comment the Amendment Proposal, and to take appropriate action for approval and integration of the AP in Doc 9880 Part II.





## Amendment Proposal (AP) to Doc 9880

<b>Title:</b>	Conversion of AFTN SVC Messages due to unknown addressee indicators
<b>AP working paper number and date:</b>	<i>To be defined by ACP WG-M</i>
<b>Document(s) affected:</b>	Doc 9880, Manual on Detailed Technical Specifications for the Aeronautical Telecommunication Network (ATN) using ISO/OSI Standards and Protocols, First Edition 2010
<b>Sections of Documents affected:</b>	Doc 9880, Part II, sections 4.4.4, 4.3.1.5 and 4.5.6.1.1
<b>Coordinators:</b>	DSNA/DTI - Jean-Marc Vacher (ON-X Contractor in support to DSNA)
<b>Coordinators address:</b>	DSNA/DTI 1 Avenue du Dr Grynfoegel BP 53584 31035 Toulouse Cedex 1 France
<b>Coordinators Phone:</b>	+33 5 6214 5474
<b>Coordinators Fax:</b>	+33 5 6214 5401
<b>Coordinators e-mail address:</b>	jean-marc.vacher@regis-dgac.net
<b>Category:</b>	(Partial) Bug
<b>Problem description:</b>	<p>There is an operational requirement that the recipient of a Non-Delivery Report or an AFTN SVC message reporting about an unknown addressee indicator (SVC ADS ... UNKNOWN ...) can identify the COM Centre which detected the situation.</p> <p>The current AFTN/AMHS gateway specification regarding processing of AFTN SVC ADS UNKNOWN messages prevents this operational requirement from being met in most cases, due a to a partial loss of information at the gateway.</p> <p>In an AFTN to AMHS to AFTN message exchange scenario, if an AFTN SVC ADS UNKNOWN message is generated, it is converted into an AMHS NDR if a single matching subject message can be found in the gateway traffic history. After re-conversion into an AFTN SVC message, the SVC message is not identical</p>

	<p>to the one originally generated by the COM Centre which detected the situation: the originator of the AFTN SVC message appears to be the gateway which converted the AMHS NDR into the AFTN SVC. This is misleading for the originator of the subject message which receives the AFTN SVC message, and in contradiction with the operational requirement described above.</p>
<b>Background:</b>	<p>See WP_-WGM-20 AFTN SVC processing in AFTN/AMHS Gateways</p> <p>A secondary conversion process (convert AFTN SVC into an IPM) is currently defined, to be selected only when the primary conversion process (conversion into an AMHS NDR) is not feasible.</p> <p>The problem resolution is to remove the choice between primary and secondary, and to make the current secondary process (conversion into IPM) the only applicable process for such AFTN SVC messages.</p>
<b>Backwards compatibility:</b>	<p>The solution is fully backwards compatible, as it is maximising the use of an already existing process (which was previously used only as a secondary solution)</p>
<b>Amendment Proposal:</b>	<p>1) Replace current section 4.4.4.1 and subsequent clauses 4.4.4.1.1/4.4.4.1.7 with a single clause (derived from current 4.4.4.1.1 and 4.4.4.1.7) as follows:</p> <p>4.4.4.1 Upon reception by the message transfer and control unit of an unknown address AFTN service message, passed from the AFTN component to be conveyed in the AMHS, the received message shall be converted into an IPM as specified in 4.4.2, with the exception of the <i>subject</i> element in the IPM heading fields, initially specified in Table 4-3/Part2/10, which is then generated and takes the value "AFTN service information".</p> <p>2) Modify 4.3.1.5 d) as follows:</p> <p>d) action taken thereon if AFTN service message in (discard, convert into AMHS report, convert into IPM);</p> <p>3) Insert a new 4.3.1.5 g) and renumber current g) accordingly:</p> <p>g) MTS-identifier of resulting message, if the AFTN service message was converted into an IPM;</p>

	<p>h) event date/time.</p> <p>4) Delete 4.5.6.1.1 b) and merge a) with the main text of the clause, to read as follows:</p> <p>4.5.6.1.1 A non-delivery report shall be generated by the message transfer and control unit for each message or probe which was rejected at the AFTN/AMHS gateway, as the result of the procedures described in 4.5.1., 4.5.1.4, 4.5.2 and 4.5.5, either for all the recipients or for certain recipients.</p>
<b>WG-M status:</b>	PROPOSED